

# NARCO AVIONICS

## MK12D TSO

(MK12, MK12A, MK12B REPLACEMENT RADIO)



### ADDENDUM INSTALLATION MANUAL 03118-0620R



NARCO AVIONICS INC.  
270 COMMERCE DRIVE  
FT. WASHINGTON, PA. 19034  
U.S.A.

NARCO AVIONICS INC.  
MK12D/R INSTALLATION MANUAL  
REVISION HISTORY

This page is provided and updated as necessary as a means of identifying pages that were changed at each revision level. The affected page number, the revision level, and the date of the change are listed. Additionally the date and revision level is changed on the bottom of the affected pages.

PAGE	DATE	REV	PAGE	DATE	REV	PAGE	DATE	REV	PAGE	DATE	REV	PAGE	DATE	REV
3	10-96	D												
5	10-96	D												
5	09-98	E												
6	09-98	E												
8	06-99	F												
9	06-99	F												

## 1.0 INTRODUCTION

### 1.1 DESCRIPTION

The MK-12D TSO ( replacement radio ) referred to here on as MK-12DR, is a modified version of the MK12D Cessna replacement radio. The MK-12DR is a direct replacement for the NARCO MK12, MK12A, and MK12B NAV/COMS.

### 1.2 FEATURES

#### GENERAL

- Active channel keep alive ( when connected ).
- Bright sunlight readable display.
- Flip-Flop frequency entry.
- Direct slide in replacement for the MK12, MK12A, MK12B.
- 14v or 28v units available.

#### COM

- 760channel TSO'd VHF transceiver.
- 7 watts nominal transmit power ( 10W typical ).
- 0.003% frequency stability.
- Automatic squelch with manual override.
- 50mw phones output.
- 10 watt audio amplifier.

#### NAV

- 200 channel TSO'd NAV receiver.
- Glideslope channeling ( 2 of 5 or Narco 11 wire ).
- DME channeling

## 2.0 INSTALLATION

### 2.1 INTRODUCTION

The MK-12DR is a direct replacement for the MK12, MK12A, MK12B NAV/COM units. It's specifications meet or exceed those of the unit it is replacing.

### 2.2 TECHNICAL SPECIFICATION AND PERFORMANCE ADJUSTMENTS

The MK-12DR is a specially modified MK-12D Cessna unit. The mechanical modifications effect the physical size, latching method, and interconnections. The electrical modifications concern the NAV receiver ( level and phase ), deleting the vor and Localizer converters, and adding selectable Glideslope channeling ( 2 of 5 or Narco 11 wire ). All pertinent adjustment information can be found in the MK-12D TSO maintenance manual ( P/N 03118-620, December 1988 or later )

#### 2.2.1 SPECIFICATION DIFFERENCES

WEIGHT: 5.8 lbs.

14V- Receive current: 1.0 amps

Transmit current: 4.3 amps

28V- Receive current: 0.5 amps

Transmit current: 2.5 amps

NAV receiver output level ( VOR): 3.0V rms

## 2.3 UNIT PART NUMBERS

MK-12DR (14V)	03118-0334
MK-12DR (28V)	03118-0336

## 2.4 TSO CONSIDERATIONS

### COM Transceiver

The COM section of the MK-12DR is designed to meet TSO's C37b-Class IV, and C38b - Class C. The existing installation into which the MK-12DR is going to be installed must be inspected to insure that the wiring and antenna meet the appropriate TSO, otherwise the TSO will not be valid.

### NAV Receiver

The NAV receiver of the MK-12DR is designed to meet VOR TSO C40b and Localizer TSO C36c- Class C. The MK-12DR when replacing a MK12, MK12A, or MK12B will typically be used with one of the VOA series indicator/converters. The following table lists these units and their TSO's if applicable.

INDICATOR/CONVERTER	TSO
VOA-4, VOA-5	NONE
VOA-8, VOA-9	C36b- CLASS c, C40a
VOA-40, VOA-50	NONE

The wiring and antenna pertaining to the NAV receiver should be inspected to insure TSO compliance.

## 2.5 PARALLEL AUDIO INSTALLATIONS

In some dual installations ( usually without audio panel) the speaker outputs of the two NAV/COMs were wired in parallel. The MK12DR TSO has a solid state speaker amplifier for improved audio response and reliability and this type amplifier cannot be paralleled. For these installation it is recommended that the installation be modified according to figure 2-1.

**Warning! Failure to comply with this section will cause damage to one or both units.**

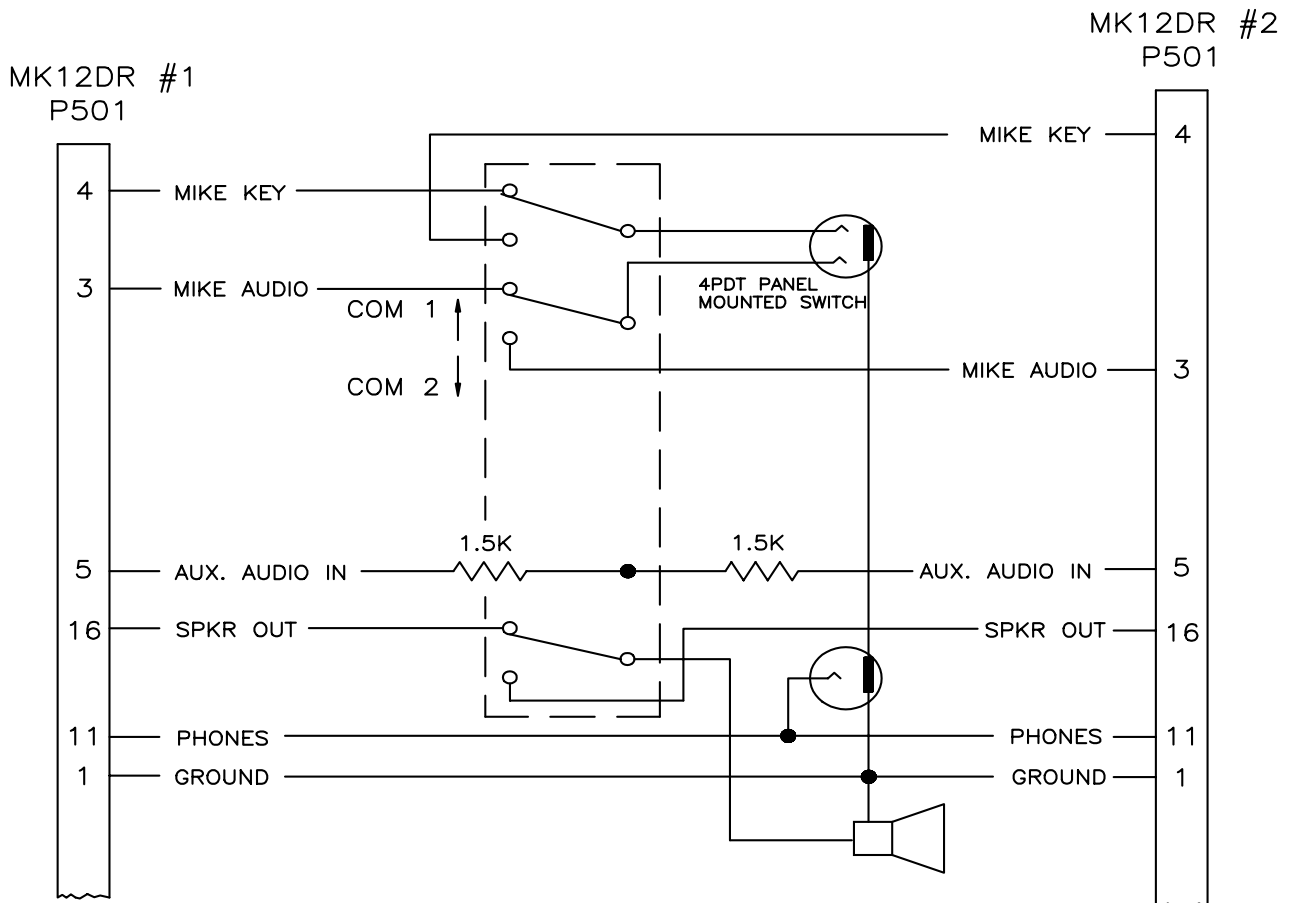

CAUTION: MK12DR MIKE AUDIO (P501-3) AND SPEAKER OUT (P501-16) MAY NOT BE PARALLELED WITH ANOTHER UNIT'S MIKE AUDIO OR SPEAKER OUT. MK12DR PHONES (P501-11) MAY BE PARALLELED WITH ANOTHER UNIT'S PHONES OUT.

FIG. 2-1

## 2.6 REMOVAL AND INSTALLATION

The existing MK12 or MK12A can be removed by first disconnecting all cables and then releasing the locking screw at the rear of the unit. The MK12B's have a front mounted cam lock that can be released by removing the snap in button on the trim panel and using a screw driver to release the radio ( some MK12B's may be installed in MK12 or MK12A trays and they would use the rear locking screw). Before installing the MK-12DR all existing cables and connectors should be inspected and cleaned. To install the MK-12DR route the cables the same as before and connect the antenna cables to the back of the unit. The MK-12DR should then be secured with either the rear latching screw. If replacing an MK12B a rear quarter turn latching screw must be used. These should be available at most shops. If DME or Glideslope channeling is needed refer to section 2.7 for instructions. For ease of removal the MK-12DR has a convenient handle that is released with a phillips head screw. The existing power unit is not needed and can be removed, the included adapter plug must be installed at the end of the power unit cable ( black wire to airframe ground ) Fig 2-7.

**Warning! Failure to remove the power unit will do severe damage to the MK12D/R.**

## 2.7 KEEP ALIVE AND REMOTE CHANNELING ( P5 )

Keep alive is no longer needed on the newer versions of the MK12D/R. Reference to keep alive on P5 is kept to be consistant with earlier versions. For installations requiring Glideslope and/or DME channeling table 2-1 list the pin connections on P5. To enable 2 of 5 Glideslope channeling pin 8 should be connected to ground. The original Glideslope and DME channeling cables should be cut off the MK12(A/B) and wired to P5 using a DB37 female connector ( supplied ). Refer to figures 2-2, and 2-3 for these channeling connections.

PIN #	FUNCTION	PIN #	FUNCTION
1	108.1/110.1, A-MHZ	20	109.1/111.1, A-KHZ
2	108.3/110.3, B-MHZ	21	109.3/111.3, B-KHZ
3	108.5/110.5, C-MHZ	22	109.5/111.5, C-KHZ
4	108.7/110.7, D-MHZ	23	109.7/111.7, D-KHZ
5	108.9/110.9, E-MHZ	24	109.9/111.9, E-KHZ
6	G.S. ACTIVATE	25	50 KHZ
7	A/B	26	GROUND
8	2/5 ENABLE	27	ARINC
9		28	
10		29	KEEP ALIVE
11		30	
12	SWITCHED A+	31	GROUND
13		32	50 KHZ
14		33	NARCO 'L', E-KHZ
15	NARCO 'A', E-MHZ	34	NARCO 'K', D-KHZ
16	NARCO 'E', D-MHZ	35	NARCO 'J', C-KHZ
17	NARCO 'D', C-MHZ	36	NARCO 'H', B-KHZ
18	NARCO 'C', B-MHZ	37	NARCO 'F', A-KHZ
19	NARCO 'B', A-MHZ		

**TABLE 2-1  
P-5 FUNCTIONS**

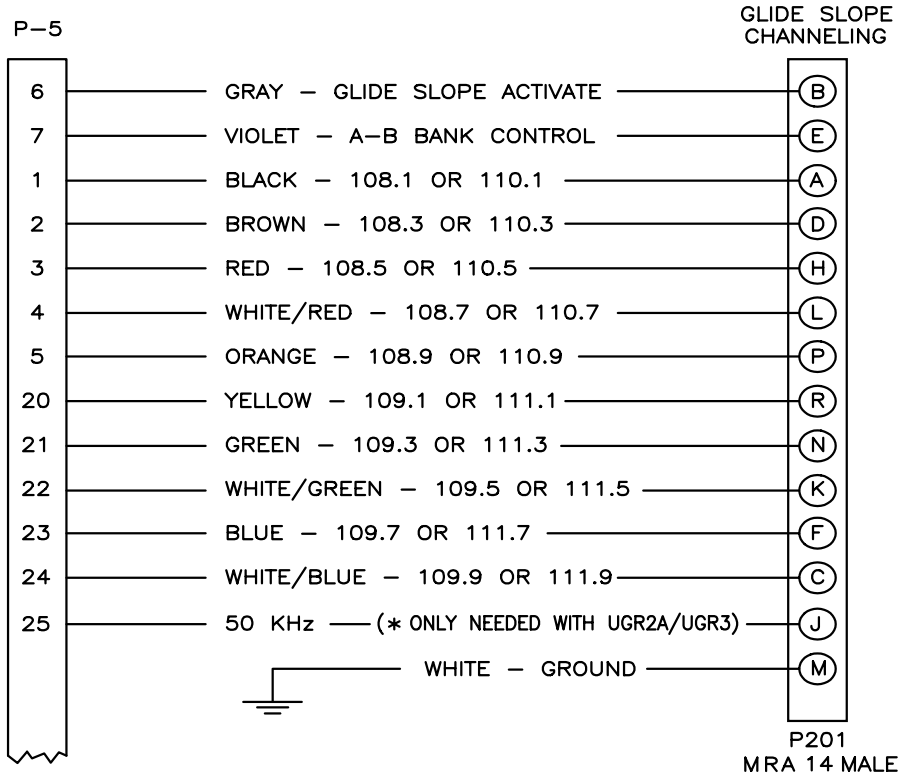

FIG 2-2 GLIDESLOPE CHANNELING

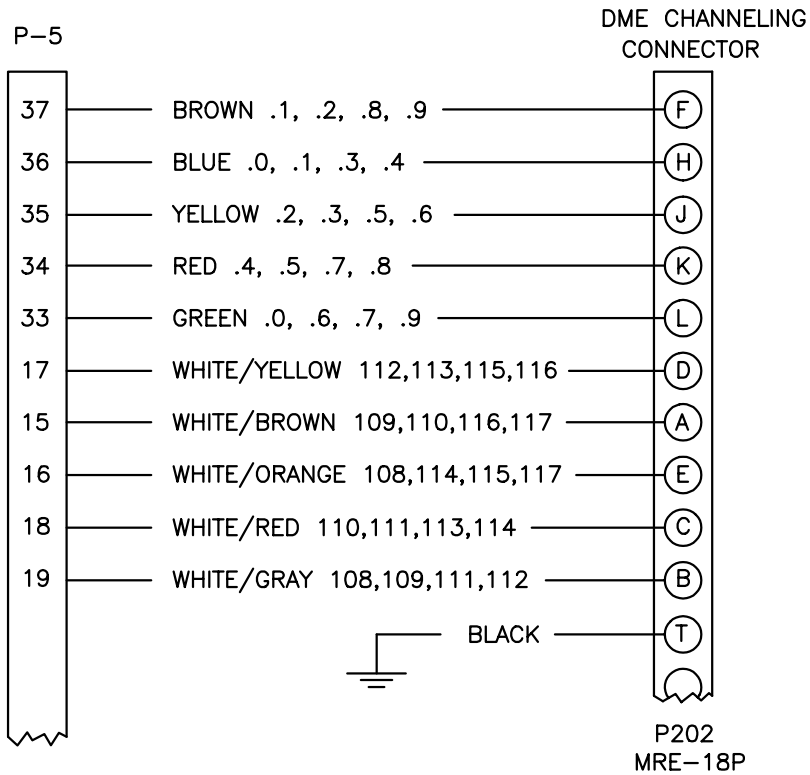

FIG 2-3 DME CHANNELING

## 2.8 EXTERNAL CONNECTIONS

Figure 2-4 shows the locations of cables, connectors and antenna inputs of the MK-12DR. Figure 2-5 shows the pinouts of the 16 pin and 6 pin connectors attached to the MK-12DR and the 16 pin jumper plug.

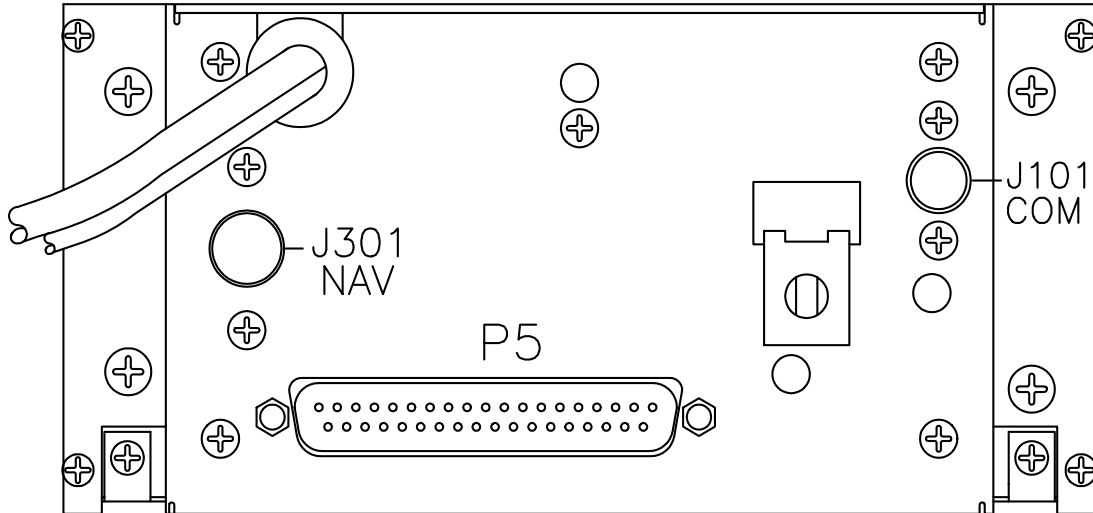

Fig. 2-4

### 2.8.1 PIPER SPECIAL

There were a number of MK12s manufactured as Piper specials. Refer to Figure 2-5 to see the rear panel of a Piper special. Figure 2-7 lists what the connections of P301 were and the appropriate connections on the MK12D/R. A mating connector for P301 of the MKD/R would have to be found to complete the installation.

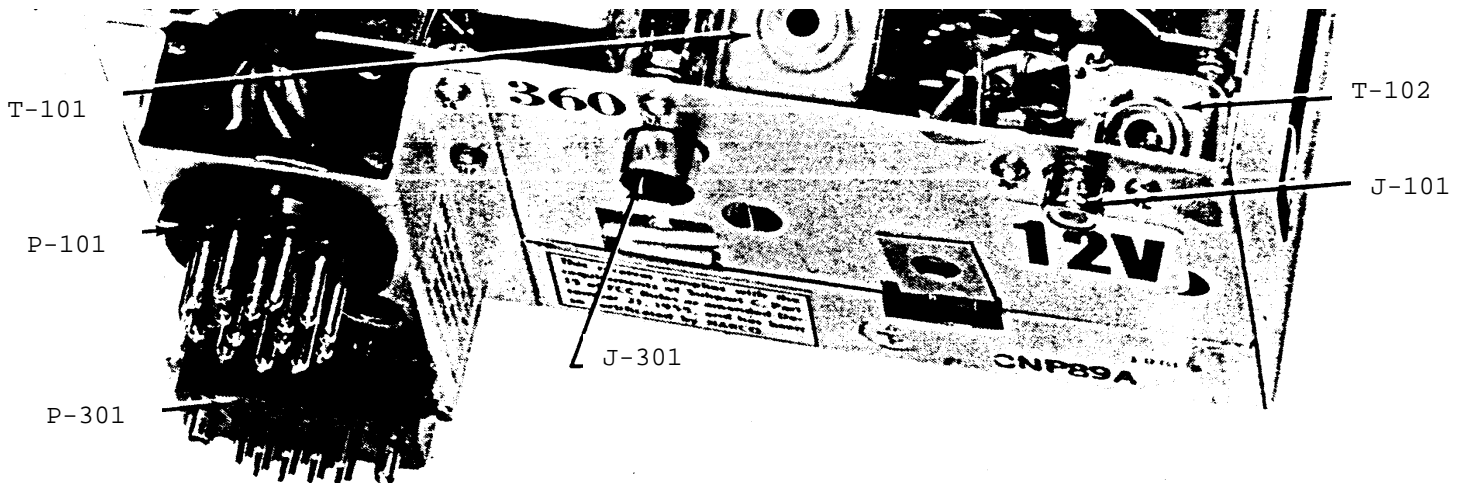

Fig. 2-5



P101		P301	
1	GROUND	1	GROUND
2	MIKE AUDIO GND.	2	SWITCHED A+
3	NC	3	NC
4	NC	4	VOR/LOC CONTROL
5	14V OR 28V INPUT	5	DIMMER
6	MIKE KEY	6	VOR/LOC SIGNAL
7	MIKE AUDIO		
8	SPEAKER OUT		
9	NC		
10	DIMMER INPUT		
11	NC		
12	AUX AUDIO IN		
13	PHONES OUT		
14	NC		
15	NC		
16	NC		

P501 JUMPER PLUG CONNECTIONS	
PIN	PIN
3	7
4	6
5	12
8	16
11	13

FIG. 2-6

MK12D/R		MK12	
P5		J301	
1	A	18.01	110.1
6	B	GLIDESCOPE	ACTIVATE
24	C	109.9	111.9
2	D	108.3	110.3
7	E	10/20 A-B BANK CONTROL	CANNEL CONTROL
23	F	109.7	111.7
3	H	108.5	110.5
25	J	N.C.	50 KHz 46 RZA/UGRS
22	K	109.5	111.5
4	L	108.7	110.7
TO AIRCRAFT GROUND	M		GROUND
21	N	109.3	111.3
5	P	108.9	110.9
20	R	109.1	111.1
<b>P301</b>			
1	S	OMNI/LOC	GROUND
	T	N.C.	
6	U	OMNI/LOC	SIGNAL
4	V	OMNI/LOC	CONTROL

Fig. 2-7

## 2.9 OPERATION

This operation procedure presumes that the MK-12DR has been installed with the Keep-Alive option

The Keep-Alive option maintains the last set COM and NAV Active frequencies in their memory IC's. When the Unit is turned ON, these "active" frequencies will be seen in the Active displays. The display's Standby frequencies will always be the factory pre-programmed frequencies of 121.90 for COM Standby and 110.50 for NAV Standby.

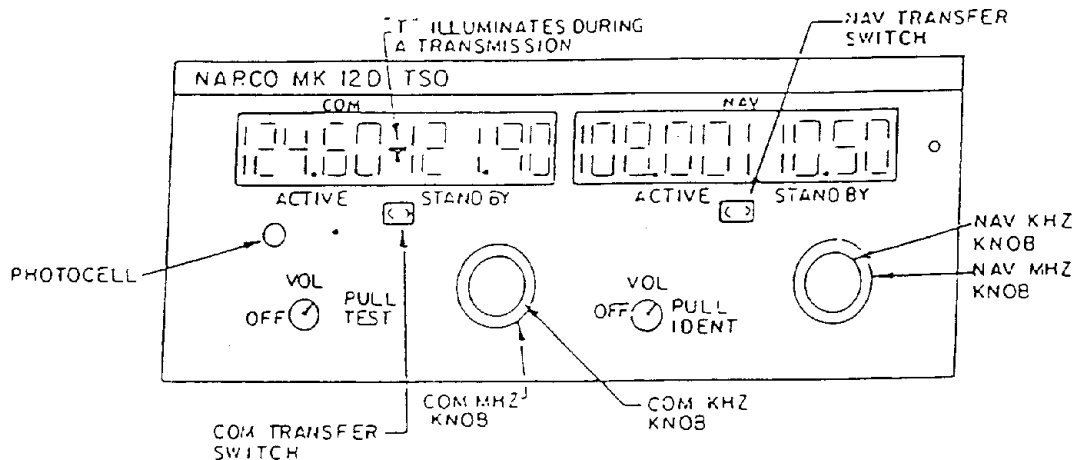

FIGURE 2-6 MK-12DR FRONT PANEL

### 2.9.1 COM Section Operation

#### COM: DISPLAY

The left side of the display identifies the COM Active COMMunications frequency, and the letter "T" (when lit) to indicate that the Mike Key is depressed and the Unit is transmitting.

The right side of the display identifies the COM Standby frequency.

#### COM: OFF-VOL-PULL TEST

OFF is the maximum counterclockwise rotation of this control. Clockwise rotation past the "click" turns both the COM and NAV Sections ON.

VOL, once the Unit is turned ON, continued clockwise rotation increases the COM audio volume.

NOTE: NAV AND COM SHARE THE AUDIO 50 mw OUTPUT.

PULL TEST when pulled deactivates the squelch circuit.

COM: MHz/KHz CHANNEL SELECT KNOBS

Both these controls allow for continuous CW or CCW rotation. MHz frequency readout, in Standby display, changes at a rate of 1 MHz per detent. Rotation of the KHz knob steps the Standby frequency readout at a change rate of 25 KHz per detent.

Clockwise rotation increments the frequency, counterclockwise decrements the frequency.

COM: HOW TO ENTER A FREQUENCY

All frequencies entered into the COM Section enter via the Standby route, that is, the frequency is entered (see in the Standby displays) and then transferred to the Active by depressing the "arrowed" transfer push button. The next frequency entered is the Standby frequency.

The Active frequency and its resultant data is not affected by the rotation of either of the MHz or KHz knobs.

COM: TRANSFER

Pressing this white arrowed momentary switch "flips" the display. The Standby frequency becomes the Active and the Active becomes the Standby. A second depression exchanges the frequencies.

2.9.2 NAV Section Operation

NAV: DISPLAY

The left side of the display identifies the NAV Active communications frequency.

The right side of the display identifies the NAV Standby frequency.

NAV: VOL-PULL IDENT

VOL, continued clockwise rotation increases the NAV audio volume.

NOTE: NAV AND COM SHARE THE AUDIO 50 mw OUTPUT.

PULL IDENT when pulled activates the IDENT circuit.

NAV: MHz/KHz CHANNEL SELECT KNOBS

Both these controls allow for continuous CW or CCW rotation. MHz frequency readout, in Standby display, changes at a rate of 1 MHz per detent. Rotation of the KHz Knob steps the Standby frequency readout at a change rate of 50 KHz per detent. Clockwise rotation increments the frequency, counterclockwise decrements the frequency.

## NAV: HOW TO ENTER A FREQUENCY

All frequencies entered into the NAV Section enter via the Standby route, that is, the frequency is entered (seen in the Standby displays) and then transferred to the Active by depressing the "arrowed" transfer push button. The next frequency entered is the Standby frequency.

The Active frequency and its resultant data is not affected by the rotation of either the MHz or the KHz knobs.

## NAV: TRANSFER

Pressing this white arrowed momentary switch "flips" the display. The Standby frequency becomes the Active and the Active becomes the Standby. A second depression exchanges the frequencies.

### 2.9.3 Loss of Display

The following is not expected, however, as there is a built-in preset Standby frequency, it can be used if the display should blackout.

If the NAV DISPLAY should have a total blackout, yet the indicator appears unaffected, verify that the station being received is the station selected prior to the blackout, pull IDENT. If you are still set to your desired frequency continue your flight, it can be presumed that you had a display or a display circuit failure.

If the COM DISPLAY should have a total blackout, verify that the COM is still set to the frequency selected prior to the blackout. Verification can be made by initiating a transmission and listening for the reply. If you are still set to your desired frequency, it can be presumed that you had a display circuit failure.

#### 2.9.3.1 Changing Frequencies With Loss of Display

### NAV SECTION:

Knowing what frequency you had set in Active and Standby windows, it is now a matter of rotating the KHz and MHz knobs clockwise (incrementing) or counterclockwise (decrementing) detent-by-detent: KHz, 05 KHz steps, MHz, 1 Mhz steps, to change frequencies. Remember all entries go into the Standby display window before they can be transferred to the Active display window.

Should it appear that in changing frequency you lost count, you may rely on the factory pre-programmed frequency of 110.50 in the Standby memory. However, you must turn the MK-12DR OFF, then ON, to automatically set 110.50 into the Standby display. (Active frequency being Kept-Alive, will not be affected by the turning OFF and ON of the Unit.)

Now channel

to the desired frequency using the detent-by-detent count off method. Transfer your blind standby frequency to the Active channel, and then verify the results. Pull IDENT.

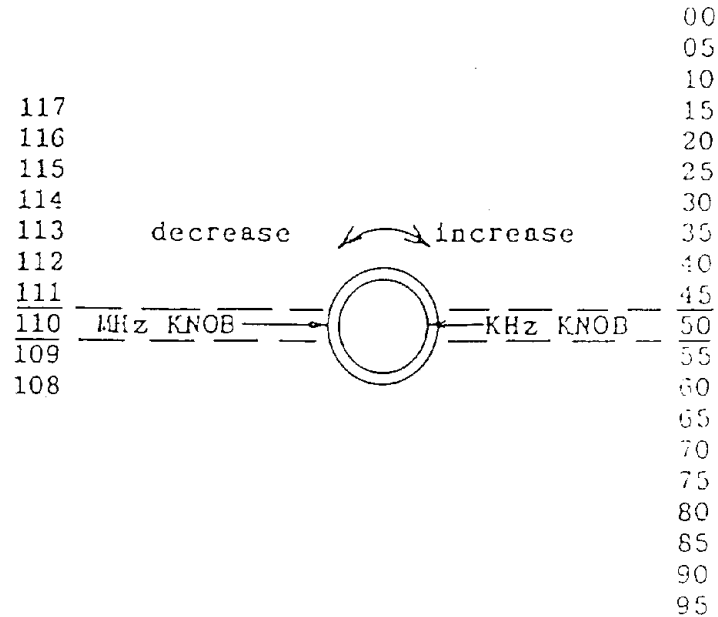

If wrong, transfer your original navigation frequency back to Active, then repeat the turn OFF, turn ON, and the detent-by-detent channel selection.

COM SECTION:

Knowing what frequency you had set in Active and Standby windows, it is now a matter of rotating the KHz and MHz knobs clockwise (incrementing) and counterclockwise (decrementing) detent-by-detent: KHz, 25 KHz steps, MHz, 1 MHz steps, to change frequencies.

Remember all entries go into the Standby display window before they can be transferred to the Active display memory.

Should it appear that in changing frequency you lost count, you may rely on the factory pre-programmed frequency of 121.90 in the Standby window. However, you must turn the MK-12DR OFF, then ON, to automatically set 121.90 into the Standby display. (Active frequency Kept-Alive, will not be affected by the turning OFF and ON of the Unit.) Now channel to the desired frequency using the detent-by-detent count off method. Transfer your blind Standby frequency to the Active window, and then verify the results.

136		00
128		70
127		72
126		75
125		77
124	decrease	80
123		82
122		85
121	MHz KNOB	KHz KNOB
120		90
119		92
118		95
		97

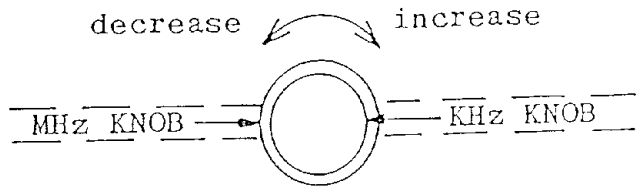

If wrong, transfer your original COM frequency back to Active, then repeat the turn OFF, turn ON, and the detent-by-detent channel selection.

## 2.10 POST INSTALLATION TESTS

This operation procedure presumes that the MK-12DR has been installed with the Keep-Alive option. All references to figures for adjustments refer to figures in the MK-12D maintenance manual.

The purpose of this series of tests is to assure proper operation of the installed avionics equipment. First, and most important, is a complete inspection of the installation to be sure that all aircraft flight controls operate freely with full travel or deflection.

Since these procedures cover Units with and without glideslope, simply bypass those functions (glideslope) which do not apply to the system being tested. A remote mounted Marker Beacon or Glideslope Receiver whose operation is dependent upon the NAV Unit being tested should be considered as an integral part of the system and included in this procedure. If an audio control panel is part of the installation, remember to select the NAV and MKR audios at the appropriate points in the procedure.

### 2.10.1 NAV Preflight Tests

For this series of in-aircraft tests, the aircraft's engine(s), rotating beacon, electrical and avionics equipments should be operating. Note any abnormal interaction of interference (ignition or rotating beacon noise, abnormal meter deflection, compass deviation, etc.) observed during these tests.

The following procedure requires a ramp type piece of test equipment such as that offered by Tel-Instrument Corp. or Instrument Flight Research, Inc.

#### A. Keep-Alive and Transfer checks.

1. Turn the MK-12DR ON. The Active display shall show a valid NAV frequency and the Standby 110.50.
2. Press the NAV transfer button and observe that the Active and Standby frequencies exchange position.
3. Reset the Active display to 114.15.
4. Turn the MK-12DR OFF and wait a minimum of 10 seconds. Turn the MK-12DR ON and observe that the Active display reads 114.15 and the Standby 110.50.

#### B. General

1. Set NAV Active channel to a VOR frequency.
2. Rotate the VOL-IDENT control clockwise until NAV Receiver noise is heard in the speaker and headphones. (Note: IDENT knob must be pulled out). Note presence of NAV and GS warning flags and centered Left-Right and Up-Down needles.
3. Modulate test equipment 30% with 1020 Hz.
4. Note presence of adequate Audio level. Depress VOL-IDENT knob and note decrease in volume level.

#### C. VOR

1. Set NAV Active display to a desired VOR frequency.
2. Set test equipment to desired VOR frequency. Modulation should be a composite VOR signal. TO/FROM switch set to the TO position.
3. Set test equipment and Indicator OBS to a Zero degree course. The Left-Right needle should center within  $\pm 2.0$  degrees ( $\pm 1.5$  degrees for TSO'd indicator) with a TO flag.
4. Turn indicator OBS knob first to 10 degrees, then to 350 degrees. The Left-Right needle should deflect to the left and right of center.

5. Check the remaining three cardinal points (90, 180, and 270). The Left-Right needle should center within  $\pm 2.0$  degrees ( $\pm 1.5$  degrees for TSO'd indicator) with a TO flag.
6. With OBS remaining at 270, set test equipment to 90. The Left-Right needle should center within  $\pm 2.0$  degrees ( $\pm 1.5$  degrees for TSO'd indicator) with a FROM flag.

#### D. LOC

1. Set test equipment and NAV Active display to a LOC frequency. Modulation should be a standard LOC centering signal. The needle should center within  $\pm 2$  needle widths ( $\pm 1$  needle width for TSO'd Indicator) with a TO flag.
2. Change modulation to .093 ddm left, then right. Deflection should be to the end of the Blue and Yellow areas on the Indicator.
3. Remove modulation or decrease test equipment RF output to minimum. NAV flag should be visible.

#### E. Glideslope

1. Set test equipment and NAV Active channel to a GS frequency. Verify that the Glideslope Receiver is channeled correctly. All 40 Glideslope channels should be checked.

#### D. DME

1. Set test equipment and NAV active channel to a DME frequency and verify that the DME is being channeled correctly. All Mhz and Khz channels should be checked.

### 2.10.2 COM General Preflight Test

With the aircraft engine(s), avionics equipment, and other on-board electronics operating, transmit and receive on several different frequencies. There should be no excessive interference and intelligible two-way communications should be demonstrated.



During this exercise make a panel illumination check:

COM READOUT SEGMENTS AND TRANSFER CHECK - Set 120.20 Active - 136.95 Standby, push arrowed white transfer button. If complete frequencies were seen in both positions - all segments are OK. (Transfer button does not illuminate.)

TRANSMIT - "T" will be seen to the right of the Active frequency whenever the Mike Key is depressed.

DIMMING CIRCUIT - The photocell, being sensitive to light, will dim the display when an opaque material is placed upon it. The display will "come back" upon taking the material away.

KEEP-ALIVE CHECK - Set the COM Active window to 120.20. Turn the MK-12DR OFF. Wait 15 seconds and turn the MK-12DR On. The Active window should display 120.20 and the Standby 121.90.

## 2.11 FLIGHT TEST

A flight test is recommend to perform the following checks and adjustments:

- A. Check all avionics under actual operating conditions for abnormal indications (ignition noise, audio distortion at in-flight volume settings, rotating beacon noise, interference between avionics equipments, etc.).
- B. Look for variations in performance due to various landing gear and flight control surface configurations.

All of these tests must be performed at an ILS facility, on an airway, and in an area where the ground station signal quality and strength has been verified.

### 2.11.1 NAV Section

#### VOR

- A. Flying at an altitude of 6000 feet above ground level (AGL), channel the NAV Active to a VOR facility 50 NM away.
  - 1. Check course accuracy, warning flag indication, and Left-Right needle sensing.
  - 2. Check the antenna pattern by flying the aircraft in a 10 degree bank completing a 360 degree turn: The warning flag should remain out of view throughout the turn and audio should remain intelligible.

- B. Flying at an altitude of 6000 feet AGL, channel the NAV Active to a VOR facility 10 NM away and fly inbound.
  - 1. Check course width .
  - 2. Observe the VOR warning flag while approaching, passing over, and flying outbound: TO/FROM indicator shall indicate correctly and the warning flag must be out of view except when passing directly over the station.
- C. Flying at an altitude of 6000 feet AGL, channel the NAV Active to a VOR facility 25 NM away and fly inbound.
  - 1. Operate the communication transceiver: VOR Left-Right indicator transient deviations should not exceed 2 dots and steady state errors should not exceed 0.5 dot.

LOC and GS

- A. Flying at an altitude of 3000 feet AGL, channel the NAV Active to a LOC frequency and fly inbound to intercept ILS.
  - 1. From point of intercept to termination of test, neither LOC or GS warning flags should appear.
  - 2. Establish glide path and fly the ILS approach: request approach control confirmation of on-glide path condition.
  - 3. While on glide path, maneuver aircraft through normal pitch and roll attitudes: Left-Right and Up-Down indicators should perform normally and a warning flag should not be visible at anytime.

DME

- A. Verify DME channeling when in flight.

2.11.2 COM section

A flight test should be performed to check the antenna pattern and system compatibility.

- A. Flying at an altitude of 6000 feet AGL establish two-way communications with a ground station facility at least 50 NM away.
- B. With the aircraft flying at 6000 feet AGL, in right and left banks (up to 10 degrees), at 10 of 12 equally spaced headings establish two-way communication with a ground station at least 50 NM away.
- C. At an altitude of 6000 feet AGL and at a distance of 20 NM from the ground facility, fly directly toward the facility and for 20 NM beyond. Maintain satisfactory communications with the facility during the test run.
- D. At a distance of 10 NM from the ground station put the landing gear and the aircraft in the approach configuration. Maintain satisfactory communications with the facility.

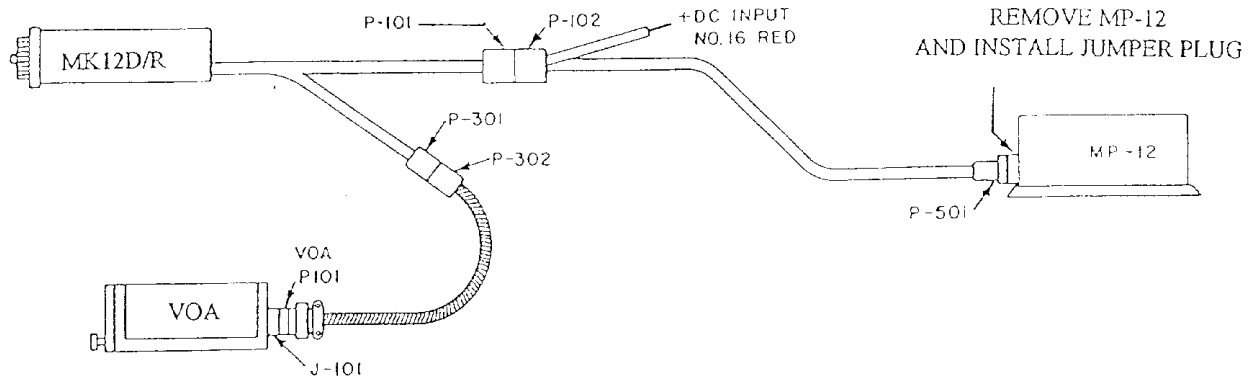

TYPICAL MK12D/R INSTALLATION  
( EXCLUDING DME, GS CHANNELING )

Fig. 2-7