

PROCOM 4 AIRCRAFT INTERCOM INSTALLATION AND OPERATION GUIDE

IMPORTANT!

- a) If a BUILT-IN, YOKE-MOUNTED, COPILOT PTT SWITCH is wired in parallel with the pilot PTT switch, it must be disconnected and wired to the ProCom 4 as shown in Figure 3. The PILOT PTT SWITCH should be left wired to the aircraft radio, but should also be wired to the ProCom 4 as shown (see Figure 3).
 - b) PLUG-IN PORTABLE PTT SWITCHES (such as the Telex Model PT-300) typically have a plug for connection to the aircraft transceiver and a jack to plug in the microphone. DO NOT PLUG THE MICROPHONE INTO THIS TYPE OF PTT SWITCH, BECAUSE THE SWITCH WILL HAVE TO BE PRESSED TO TALK OVER THE INTERCOM! Plug the portable PTT switch into the existing hand microphone jack, and plug the microphone into the jack wired to the ProCom 4 as shown in Figure 3.
-

TELEX®

TELEX COMMUNICATIONS, INC.
9600 Aldrich Ave. So., Minneapolis, MN 55420 U.S.A.

INTRODUCTION

GENERAL

The Telex Model ProCom 4 is a compact, panel-mounted aircraft intercom. It provides noise-free, voice-activated communications for a pilot, copilot, and up to three passengers. It has provisions for connections of a music/auxiliary source and a tape recorder to record all pilot/ATC communications.

FEATURES

IMPROVED SQUELCH (voice activation): The ProCom 4 is equipped with a master squelch control and individual squelch circuits with trimmers for pilot, copilot and passengers. Only the microphone of the person talking is "hot", resulting in less noise. In addition, using separate squelch trimmers solves squelch adjustment problems caused by such things as different ambient noise levels at different microphones throughout the cockpit, several types of microphones being used, and different user voice levels.

SEPARATE HEADPHONE VOLUME CONTROLS: Separate controls for pilot and copilot. Single control for passengers.

MODE SWITCH: Three operating modes (see Mode Switch Operation Table for operational summary).

PTT SWITCHING: Pilot PTT access via existing yoke switch. Copilot access via single-pole, momentary contact switch (Telex PT-300 or equivalent). Pilot has transmit priority over copilot.

MOUNTING FLEXIBILITY: Reversible faceplate permits horizontal or vertical mounting in control panel.

FAIL-SAFE SWITCHING: In the event of an intercom failure, the pilot can still use the aircraft radio by turning the intercom off.

INSTALLATION REQUIREMENTS

Installation by a qualified avionics technician is recommended. Requires additional cabling and jacks for installation. Cabling should be of a type approved for airframe and internal avionics. Power and ground wiring should be at least 20-gauge. All other wiring should be at least 22-gauge. Power must be supplied through a separate breaker, or fuse (fuse and holder supplied, power cable is not). All connections to the intercom are made using crimp-on terminals which are then inserted into a Molex connector housing on the rear panel of the ProCom 4. The connector housing and terminals are provided with the ProCom 4.

SPECIFICATIONS

POWER REQUIREMENT: 12-28 volts dc, 125 milliamps maximum with 28-volt dc aircraft supply.

FUSE: 0.25 amp, 250-volt fast blow.

HEADPHONES: 150-600 ohm impedance general aviation headphones (noise attenuating types recommended for best results). Separate outputs for pilot, copilot and up to three passengers. Power output: 120 milliwatts into 150 ohms with 28-volt dc aircraft supply (800 mW total continuous).

MICROPHONES: Carbon, or carbon-equivalent amplified microphones (noise cancelling types recommended but not required). Separate microphone inputs for pilot, copilot and up to three passengers.

MUSIC/AUXILIARY PROGRAM: Accepts either monaural or stereo, high-level, low-impedance input (such as headphone or speaker source). (ProCom 4 output is monaural.) Music level is automatically reduced by approximately 12 dB during voice communications.

CONTROLS:

Power off/on switch. (In the off position, the pilot microphone and headphones are switched directly to the radio for fail-safe operation.)

Separate pilot and copilot volume controls. Single passenger volume control.

Squelch control, with separate squelch trimmers for pilot, copilot, passenger no. 1 and extra passenger, and passenger no. 2.

Three-position mode switch.

Music/auxiliary input level trimmer.

Radio equalization trimmer: Equalizes headphone volume when switching between intercom and radio.

INDICATORS: LED transmission indicator illuminates when either pilot or copilot transmits.

WEIGHT: 0.61 lbs.

DIMENSIONS: See Figure 1.

ORDERING INFORMATION

ProCom 4 Aircraft Intercom	Catalog No. 70650-000
With fuse and holder, Molex connector kit, mounting template, and instructions	
Jack Kit	Catalog No. 70633-000
Includes four 0.206-inch dia microphone jacks, and four 0.250-inch dia phone jacks with mounting hardware	
Molex Connector Kit	Catalog No. 70625-000
Includes edge connector, polarizing key, terminals and mounting hardware	

DIMENSIONS

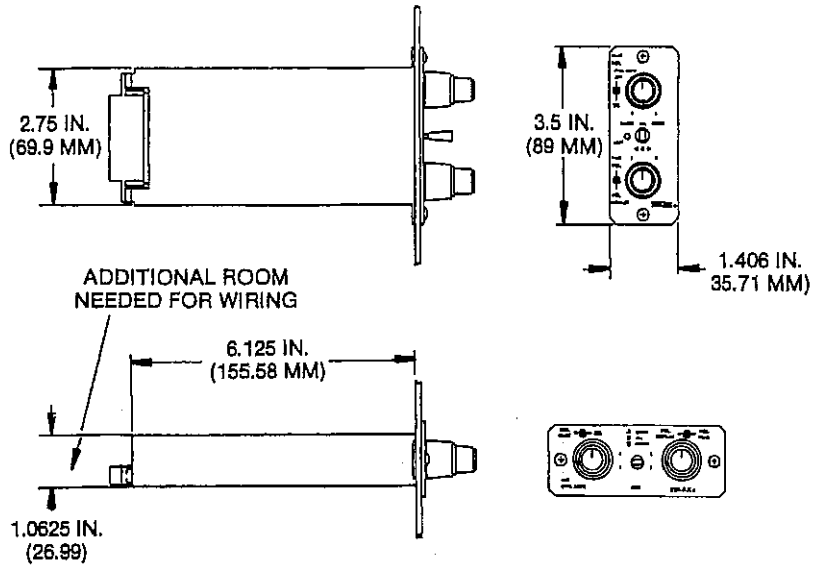

CONTROLS

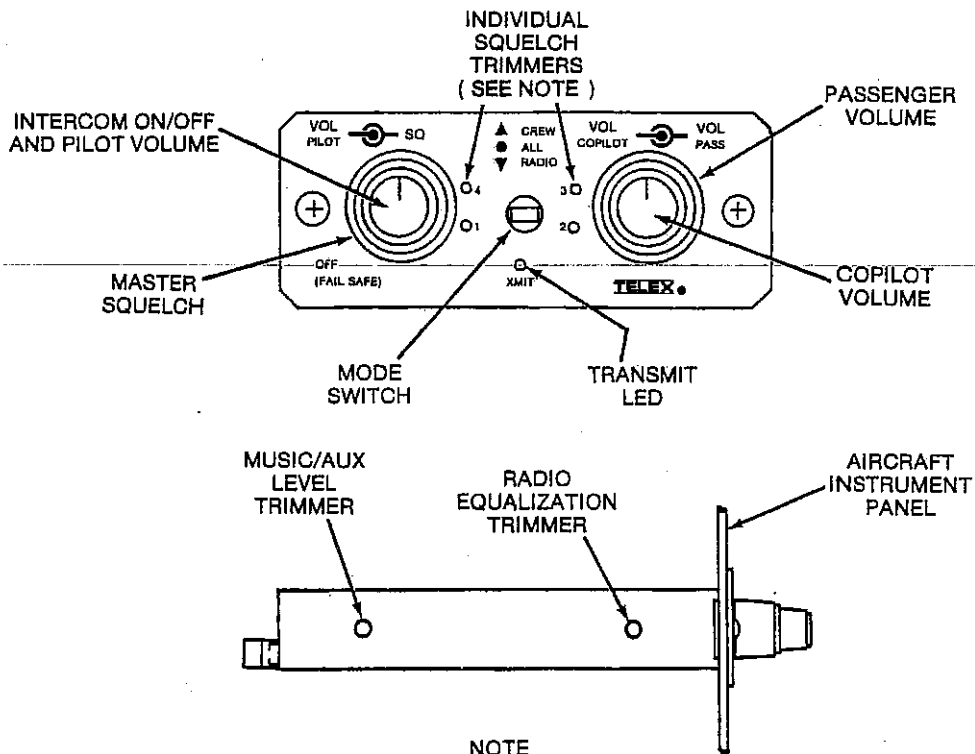

NOTE

SQUELCH TRIMMERS (1) PILOT, (2) COPILOT, (3) PASSENGER NO. 1 AND EXTRA PASSENGER, (4) PASSENGER NO. 2. CLOCKWISE ROTATION DECREASES SQUELCH ACTIVATION LEVEL.

Figure 1. ProCom 4 Intercom Reference Guide

OPTIONAL MODIFICATIONS

1. For proper operation, the aircraft radio should have sidetone during transmission. If it does not, the ProCom 4 should be modified prior to installation to simulate sidetone as described below.
2. The ProCom 4 mutes music by approximately 12 dB during voice communication. To obtain full muting, the ProCom 4 may be modified prior to installation as described below.

Modification Procedure (See Figure 2)

1. Disassemble the unit as shown.
2. To simulate sidetone, remove CR9 (for pilot sidetone) and CR13 (for copilot sidetone) as shown.
3. For full muting of music, remove R113 as shown.
4. Carefully reassemble unit by reversing disassembly sequence.

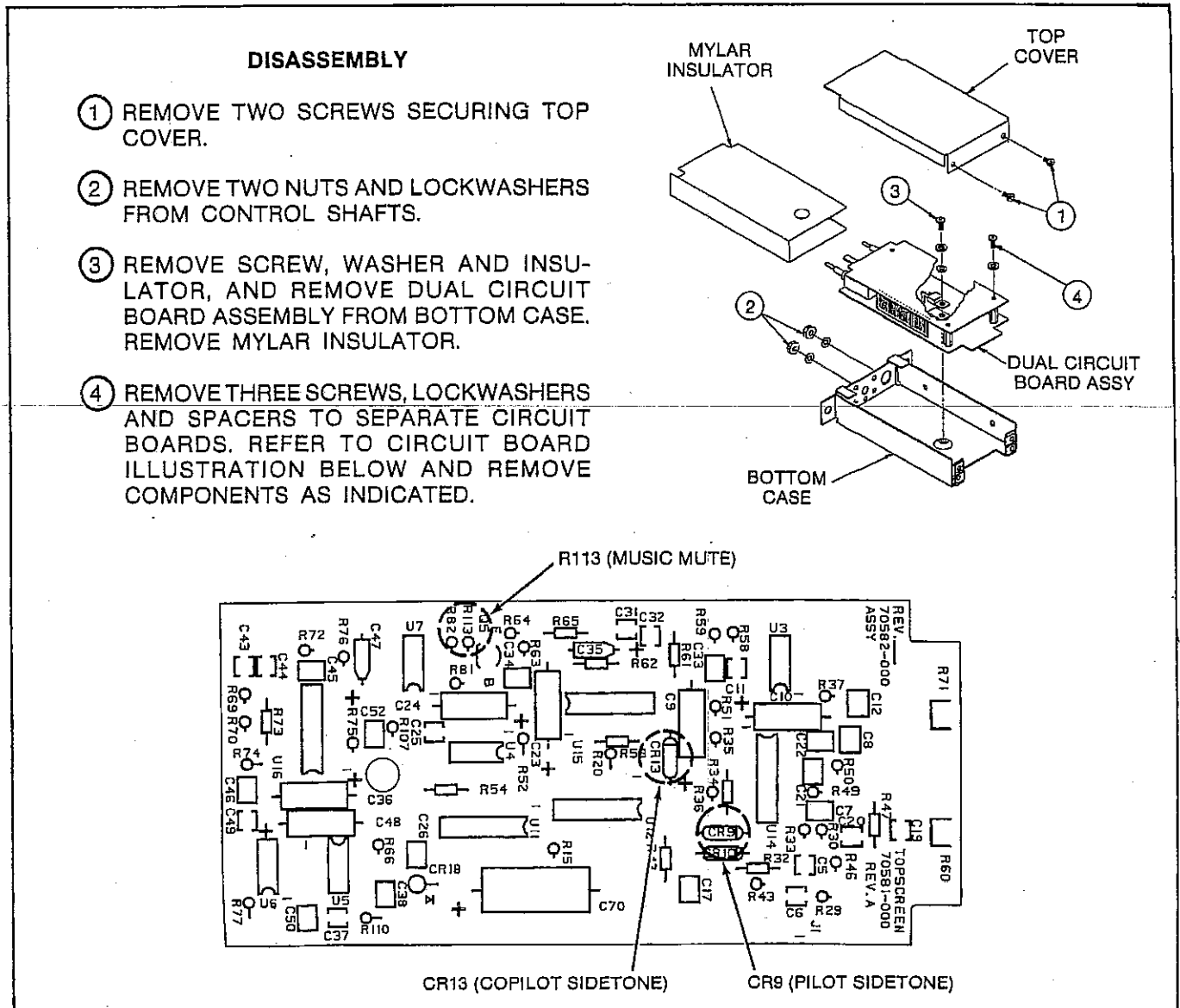

Figure 2. Optional Modifications

INSTALLATION

Intercom Wiring (Figure 3)

Before mounting the ProCom 4, make all required connections as indicated in Figure 3 using the supplied connector and terminals. Secure connector to back of intercom using hardware supplied with connector.

NOTES:

1. The most ideal hook-up is when all grounds are connected to the ProCom 4 as shown to prevent ground loops and noise. The ProCom 4 has three separate ground pins. Pin 6 is the aircraft power ground. Pin 7 is the headphone ground. Pin 5 is the microphone ground. All similar grounds should be tied together at the ProCom 4.
2. For proper intercom operation, the aircraft radio must have sidetone during transmission. If it does not, the ProCom 4 must be modified to simulate sidetone. See Optional Modifications.

Intercom Location Selection and Preparation

CAUTION

When selecting a location for installation of the intercom, move all aircraft controls over their full range of travel to make sure there will be no interference at the selected location.

1. Peel off backing and position template on aircraft panel at selected location.
2. Center punch each hole (ten total) at cross lines.
3. Drill 1/8-inch pilot holes at all locations.
4. Enlarge holes to dimensions indicated on the template.
5. Remove template.

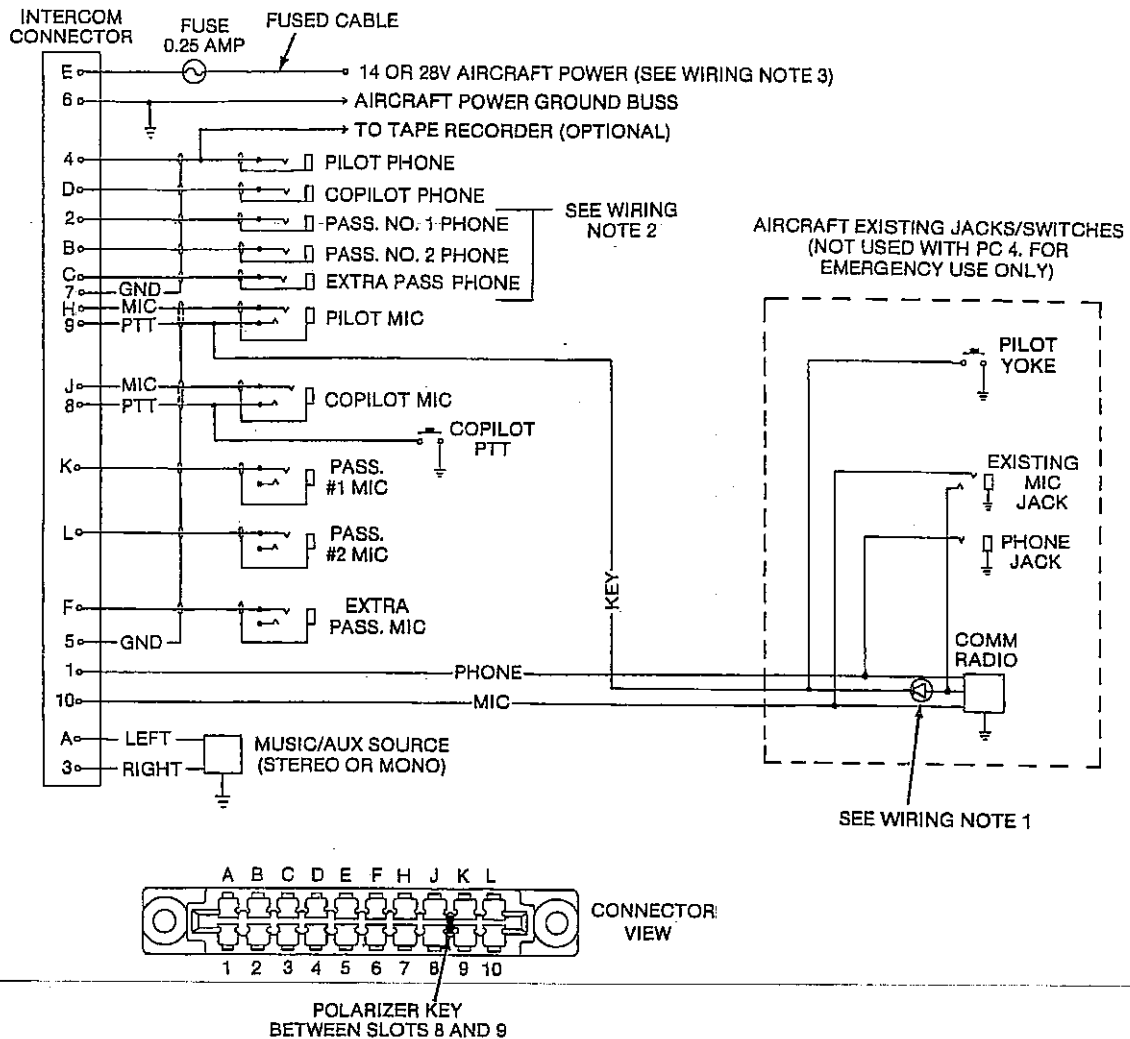

WIRING NOTES:

1. SOME TRANSCEIVERS DO NOT ISOLATE THEIR TRANSMIT RELAY FROM THE TRANSMIT KEY LINE WITH A DIODE. IF THIS TYPE OF TRANSCEIVER LOSES POWER OR IS TURNED OFF, IT WILL PULL THE TRANSMIT KEY LINE LOW, CAUSING THE PROCOM 4 TO MUTE THE PILOT HEADPHONES. (COPILOT AND PASSENGER POSITIONS REMAIN FULLY FUNCTIONAL.) TO PREVENT THIS, CONNECT A DIODE (1N4001 OR EQUIVALENT RECOMMENDED) IN SERIES WITH THE TRANSMIT KEY AS SHOWN.
2. IF DESIRED, THE HEADPHONE HOT TERMINALS ON ALL PASSENGER PHONE JACKS MAY BE TIED TOGETHER AND RETURNED TO INTERCOM CONNECTOR PIN 2, B OR C.
3. THE INTERCOM MAY BE POWERED USING THE SUPPLIED FUSE AND FUSE HOLDER, OR OPTIONALLY VIA A SEPARATE 1-AMP CIRCUIT BREAKER (NOT SUPPLIED).

Figure 3. Intercom Wiring Diagram

Intercom and Jack Mounting (Figure 4)

1. Insert ProCom 4 through aircraft panel from rear, and install faceplate and two mounting screws.
2. Install control knobs on shafts, and secure using a hexagon wrench. (Hexagon wrench size is 0.050 for the small knob and 0.062 (1/16) for the large knob.) Check knobs for smooth rotation. If friction or rubbing is noted, loosen knobs and increase spacing.
3. Install pilot, copilot and passenger microphone and headset jacks.

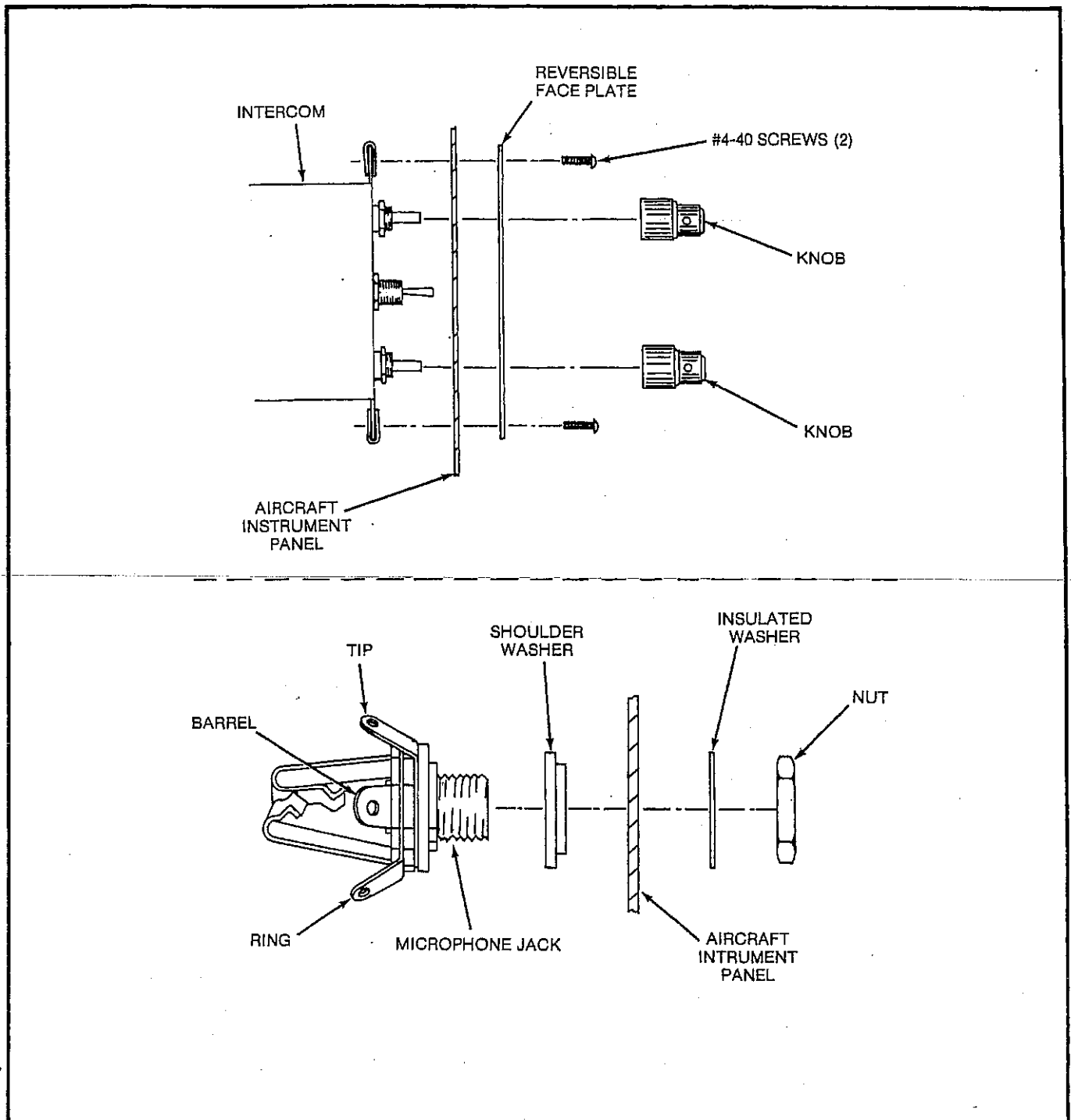

Figure 4. Intercom and Jack Mounting

SYSTEM CHECKOUT AND OPERATION

1. Turn on the ProCom 4, aircraft radio and music source. Adjust the volume of the aircraft radio and music source to the desired listening level when using the cabin speaker.
2. Plug in pilot, copilot and passenger headsets and check for proper intercom operation in the three mode switch positions as summarized in the following table.

Mode Switch Operation

MODE SWITCH POSITION	TALK ON INTERCOM	AIRCRAFT RADIO		MUSIC/AUX SOURCE (See Note 1)
		LISTEN	TRANSMIT	
Radio (Pilot Isolate)	Copilot Passengers	Pilot	Pilot	Copilot Passengers See Note 2
All	Pilot Copilot Passengers	Pilot Copilot Passengers	Pilot Copilot	Pilot Copilot Passengers See Note 3
Crew	Pilot & Copilot on one channel Passengers on a separate channel	Pilot Copilot	Pilot Copilot	Passengers Only See Note 2

NOTES:

1. Fully muted music is obtained by removal of R113 from ProCom 4.
(See Optional Modifications.)
2. Music is partially muted by talk.
3. Music is partially muted by aircraft radio audio or talk.

3. If necessary, adjust the intercom's radio equalization trimmer so that the pilot's headphone volume level is the same when switching between the intercom and the radio.
4. If necessary, adjust the music level trimmer for the desired listening level.

SYSTEM CHECKOUT AND OPERATION (Continued)

5. Set the squelch level as follows:
 - a. Turn control clockwise until sound is heard in the headphones. Now slowly rotate control counterclockwise until the headphone sound just stops. Rotate the control slightly farther counterclockwise. The sound should come back on if someone talks into a microphone.
 - b. Occasionally squelch adjustment problems may be caused by such things as different ambient noise levels at different microphones throughout the cockpit, several types of microphones being used, and different user voice levels. Use the squelch adjustment trimmers to compensate for these variations. For example: if the squelch seems to be activated too easily at one microphone position, adjust the squelch trimmer for that position to a higher squelch level (counterclockwise).
6. If a tape recorder is being used to record ATC/pilot communications, check that it is operating correctly.
7. If an intercom failure occurs, or it is desired to use the radio but not the intercom, turn the intercom off.
8. Unused headsets plugged into the ProCom 4 may cause feedback (whistling) in the intercom. To prevent this, turn down the volume controls for these headsets or unplug them.

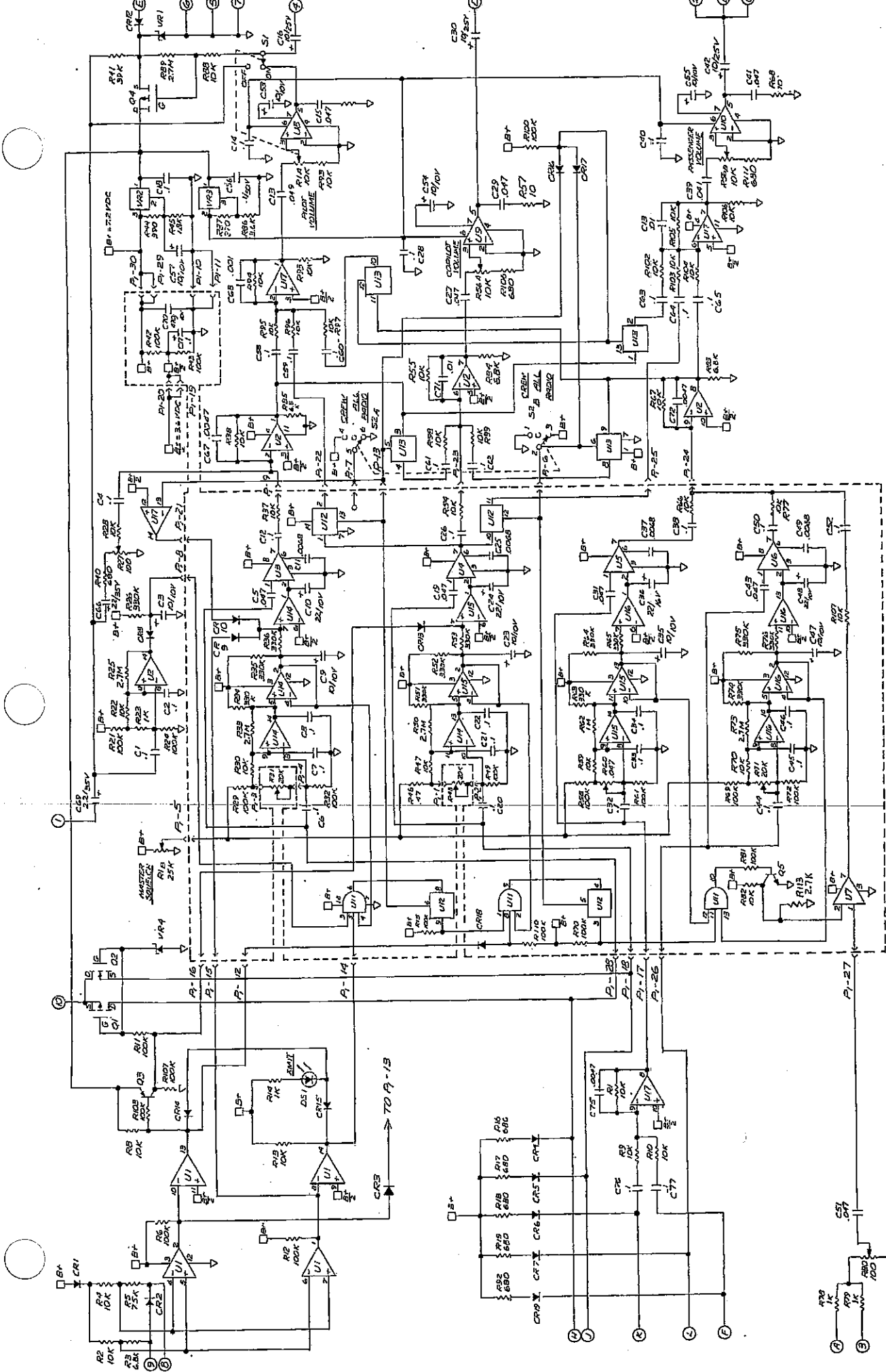

- F EXTRA PASS. MICROPHONE
- H PILOT MICROPHONE
- J COPILOT MICROPHONE
- K PASS. NO. 1 MICROPHONE
- L PASS. NO. 2 MICROPHONE

- A MUSIC, LEFT
- B PASS. NO. 2 PHONE
- C EXTRA PASS. PHONE
- D COPILOT PHONE
- E AIRCRAFT POWER

- 6 POWER GROUND
- 7 PHONE GROUND
- 8 COPILOT/PTT
- 9 COMM. RADIO PTT/PILOT PTT
- 10 COMM. RADIO MICROPHONE

- 1 COMM. RADIO HEADPHONE
- 2 PASS. NO. 1 PHONE
- 3 MUSIC, RIGHT
- 4 PILOT PHONE/TAPE IN
- 5 MICROPHONE GROUND

Figure 5. ProCom 4 Intercom Schematic Diagram