

MM IN
 1.02 .040
 1.52 .060
 5.84 .230
 7.87 .310
 5.75 .220
 8.29 .320
 1.59 .060
 6.16 0.240
 6.64 0.260

50047-01

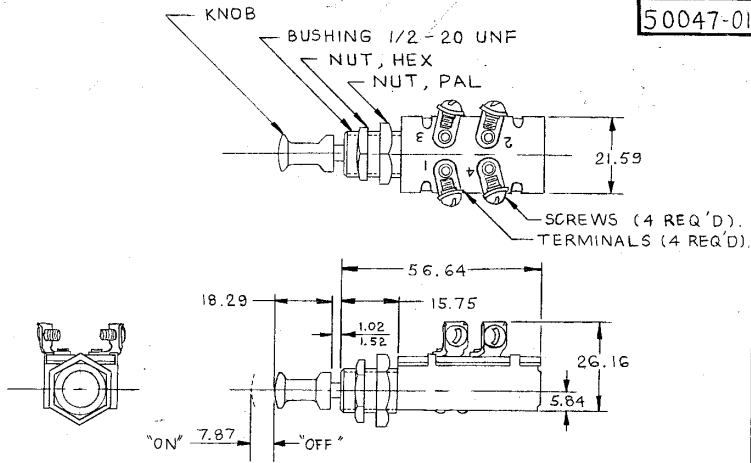

NOTE:
 Ⓢ I. ALL STEEL PARTS PLATED.

METRIC

DO NOT SCALE

LET.	WAS	DATE	BY	LET	WAS	DATE	BY	MATERIAL	DRAWN	CHECKED	APPROV'D	SCALE	DATE DRAWN
								#	CW	AF		1:1	9-12-68
								FINISH NOTED	 <small>INCORPORATED 1907 - BOSTON, MASS. U.S.A.</small>				DATE BLUEPRINT
								TOLERANCES DECIMAL ± METRIC ±.25					SW. PUSH-PULL D.P.S.T.

50082

	MM	IN
5	59	0 220
7	87	0 310
15	75	0 620
19	30	0 760
22	61	0 890
28	45	1 120
29	72	1 170

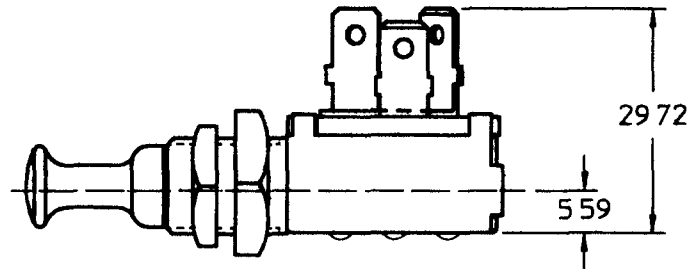
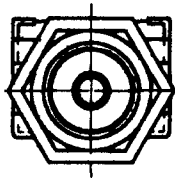
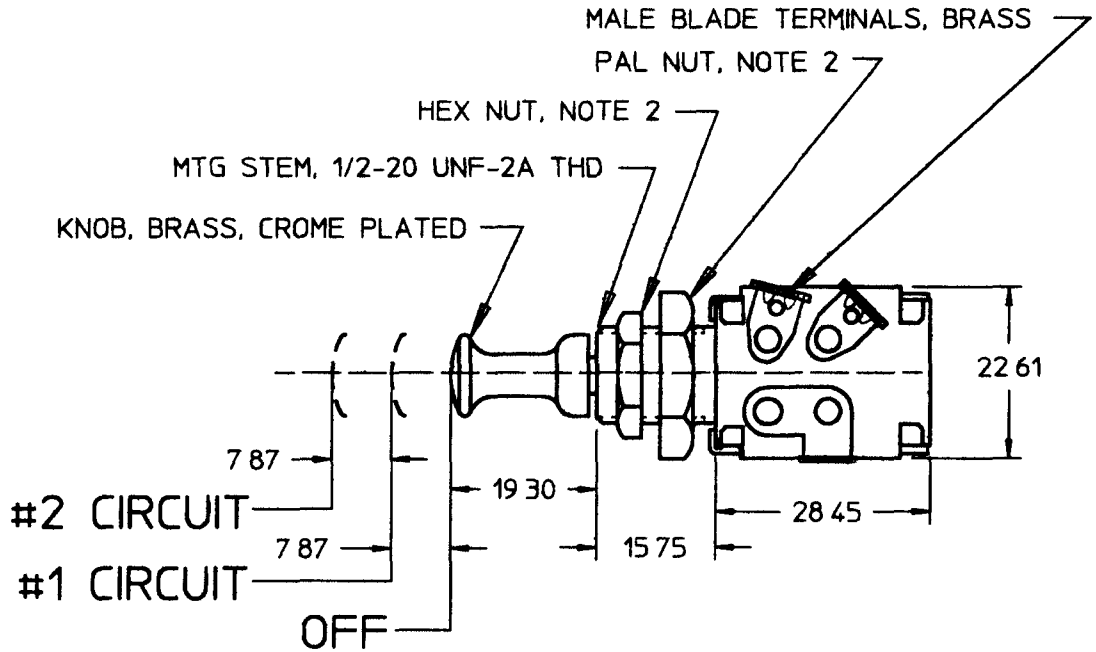

NOTE
 1 ALL STEEL PARTS PLATED
 2 PARTS MAY BE ASSEMBLED
 OR SUPPLIED IN A BAG
 3 RATING 10 AMPS @ 12 V

METRIC

DO NOT SCALE

LET	WAS	DATE	BY	LET	WAS	DATE	BY	MATERIAL	DRAWN	CHK	APVD	SCALE	DATE DRAWN
									EA	JMP		11	10/21/65
								FINISH	Cole Hersee Co. 20 OLD COLONY AVENUE, BOSTON, MA, U.S.A. 02127				DATE BLUEPRINTED
				E	PUT ON CAD ECN #26936	8/14/97	AJS	TOLERANCES DECIMAL ± ANGLE ±	SW, P-P, 3POS				50082

COLE-HERSEE CO.

T6E 1002

5050
CHARTED

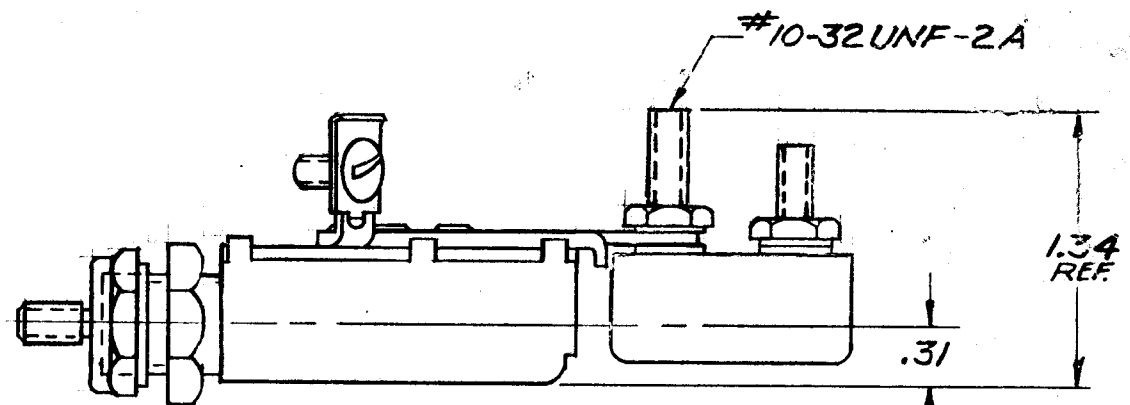
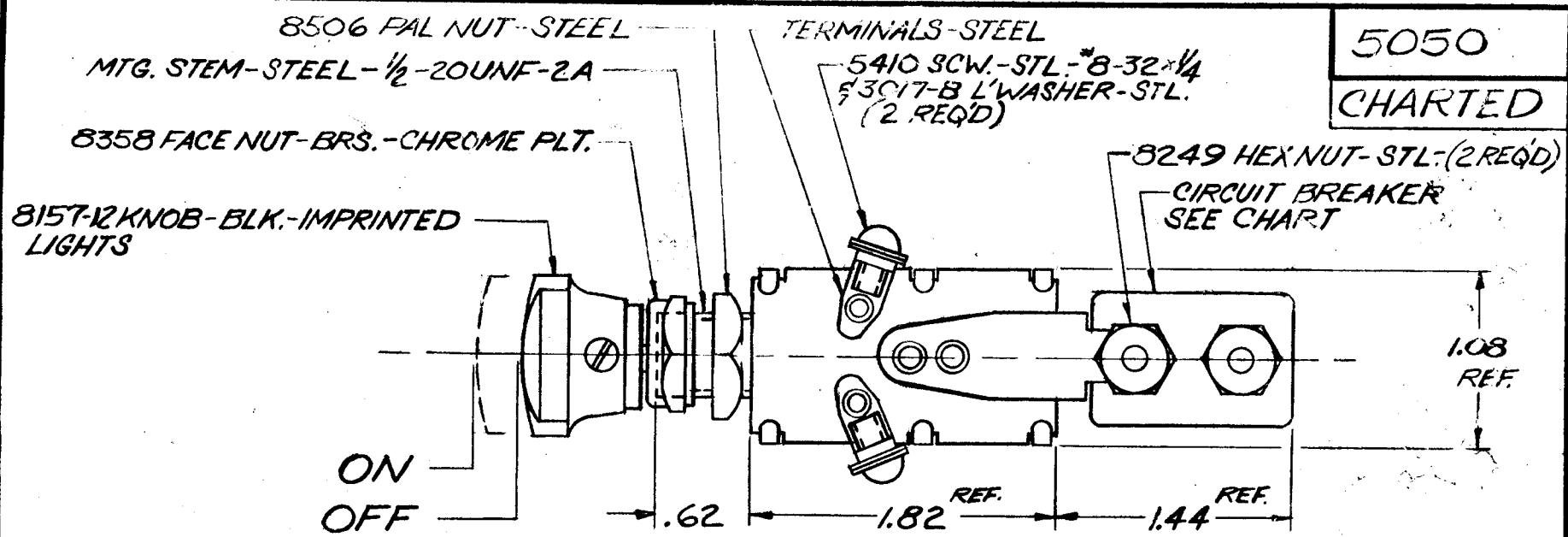

NOTES:
1. SILVERED CONTACT SURFACES
2. ALL STEEL PARTS PLATED

5050-10	SEE SEPARATE DWG	
5050-09	SEE SEPARATE DWG	
5050-08	SEE SEPARATE DWG	
5050-07	P30056-40	40
5050-06	P30056-25	25
5050-05	P30056-20	20
5050-04	P30056-15	15
5050-03	P30056-10	10
5050-02	P30056-8	8
5050-01	P30056-6	6
5050	P30056-30	30
PART NO.	CIRCUIT BREAKER	AMPS

Handwritten notes:
Junk
Mark
Mark

DO NOT SCALE

LET	WAS	DATE	BY	LET	WAS	DATE	BY	MATERIAL	DRAWN	CHECKED	APPRV'D.	SCALE	DATE DRAWN
									LG	LPG		FULL	5-7-72
				S	25234	10/20/72	JH	FINISH	COLE-HERSEE COMPANY BOSTON, MASS. 02127, U.S.A.				DATE BLUEPRINT
				R	-08-09-10 ADDED	1-15-76	LY	TOLERANCES					PUSH-PULL SWITCH
				Q	REDRAWN CHART ADDED	7-26-78	CT	FRACTIONAL ± DECIMAL ±.01					

SPAULDING CO., INC. 47570

MM	IN
25	010
58	220
74	620
03	710
60	890
44	1,120
75	1,250

5066

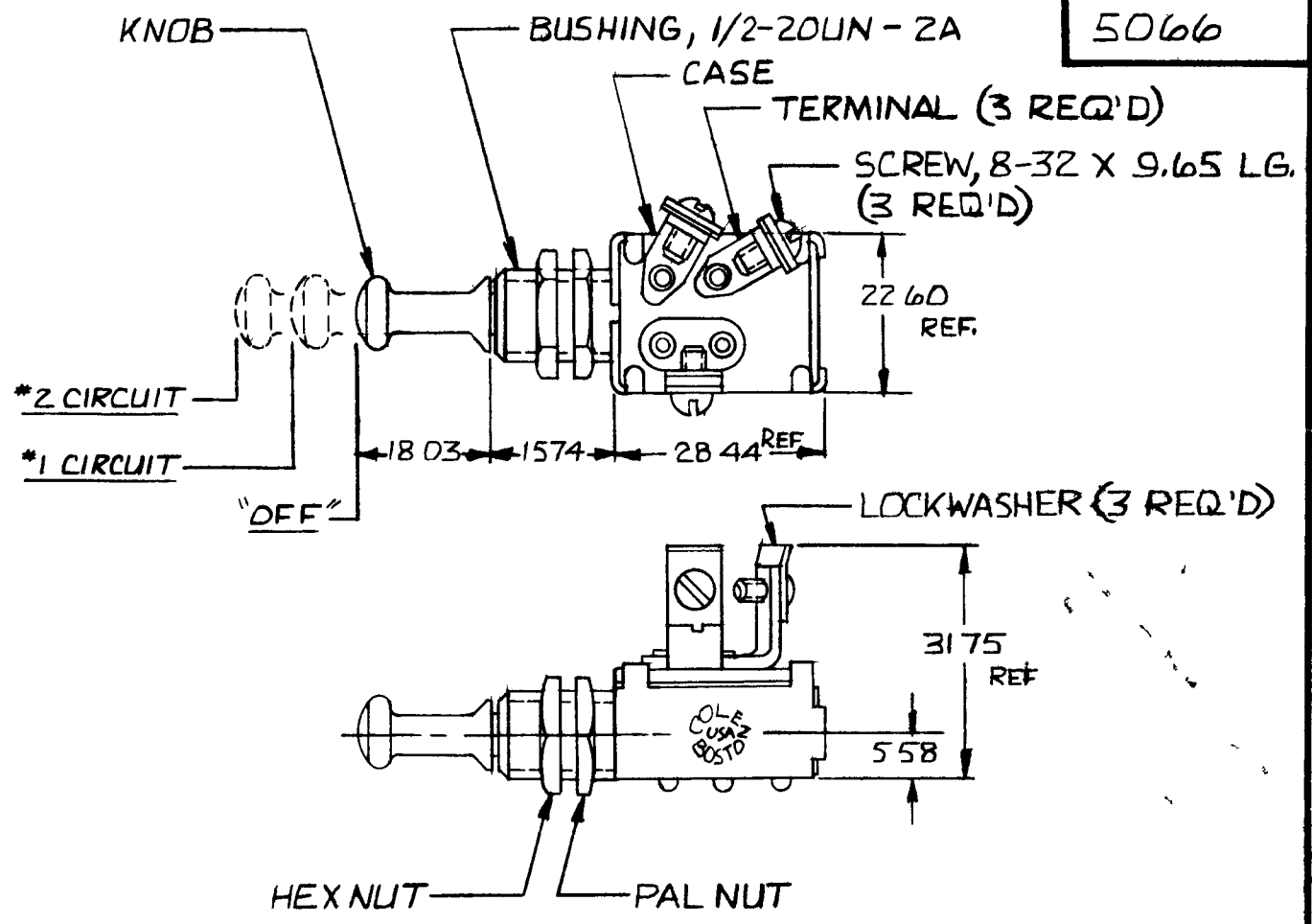

NOTES'

- 1. 8 AMPS @ 12V DC
- 2. ALL STEEL PARTS PLATED

METRIC

DO NOT SCALE

LET	WAS	DATE	BY	LET	WAS	DATE	BY	MATERIAL	DRAWN	CHECKED	APPR'D	SCALE	DATE DRAWN
								—H—	DS	RA		1:1	1-20-48
								FINISH —H—					DATE BLUEPRINT
								TOLERANCES DECIMAL ± METRIC ±.25					PUSH-PULL SWITCH
				P	REDRAWN	12980	Ⓡ						

CH 188(4 78)