

Raytheon Aircraft

Beech Bonanza®

F33A (CE-748, CE-772 AND
AFTER)

F33C (CJ-149 AND AFTER)

V35B (D-10097, D-10120 AND
AFTER)

A36 (E-1111, E-1241 THRU
E-1945, E-1947 THRU
E-2103, E-2105 THRU
E-2110)

A36TC (EA-1 thru EA-241,
EA-243 thru EA-272)

B36TC (EA-242, EA-273 thru
EA-319, EA-321 thru
EA-388)

Courtesy of Bomar Flying Service
www.bomar.biz

Wiring Diagram Manual

NOTE

This manual was formerly called the Beechcraft Bonanza Wiring Diagram Manual

Copyright © Raytheon Aircraft Company 1999

Published By
RAYTHEON AIRCRAFT COMPANY
P. O. Box 85
Wichita, Kansas 67201
U.S.A.

NOTE

Where Beech Aircraft Corporation or Beechcraft is referred to in this publication, it will be taken to read Raytheon Aircraft Company.

Raytheon Aircraft

Beech
Hawker

 Member of GAMA
General Aviation
Manufacturers Association

Raytheon Aircraft

BEECH BONANZA WIRING DIAGRAM MANUAL

LIST OF EFFECTIVE REVISIONS

Always destroy superseded pages when you insert revised pages.

Title Page January 29, 1999
Logo Page
"A" Page E1

PART NUMBER	DATE	CHAPTERS AFFECTED
35-590102-9	March 31, 1978	Original Issue
35-590102-9B	March 21, 1980	Reissue
35-590102-9C	September 11, 1981	Reissue
35-590102-9D	December, 1994	Reissue
35-590102-9E	October, 1995	Reissue
35-590102-9E1	January 29, 1999	Reference Designator Index, Part Number Index, 21, 24, 25, 32, 33, 39 and 91

NOTE: A List of Effective pages will be in the front of each chapter.

E1

Basic publications are assigned a part number which appears on the title page with the date of the issue. Subsequent revisions are identified by the addition of a revision code after the part number. A1 after a part number denotes the first revision to the basic publication, A2 the second, etc. Occasionally, it is necessary to completely reissue and reprint a publication for the purpose of obsoleting a previous issue and outstanding revisions thereto. As these replacement reissues are made, the code will also change to the next successive letter of the alphabet at each issue. For example, B for the first reissue, C for the second, etc.

When ordering a handbook, give the basic number, and the reissue code when applicable, if a complete up-to-date publication is desired. Should only revision pages be required, give the basic number and revision code for the particular set of revision pages you desire.

Raytheon Aircraft

INSTRUCTION PAGES

REVISION 35-590102-9E1

TO THE

35-590102-9E

Beech Bonanza Wiring diagram Manual - Reissued: October, 1995

REMOVE PAGE	INSERT PAGES	DATED
Title Page	Title Page	01/29/99
Logo Page	Logo Page	None
“A” Page	“A” Page	E1
Reference Designator Index-Effectivity Page 1	Reference Designator Index-Effectivity Page 1	01/29/99
Reference Designator Index Page 1 thru Page 36	Reference Designator Index Page 1 thru Page 38	01/29/99 01/29/99
Part Number Index-Effectivity Page 1	Part Number Index - Effectivity Page 1	01/29/99
Part Number Index Page 1 thru Page 36	Part Number Index Page 1 thru Page 37	01/29/99 01/29/99
21-Contents Page 1	21-Contents Page 1	01/29/99
21-50-01 Page 3	21-50-01 Page 3	01/29/99
21-50-02 Page 3	21-50-02 Page 3	01/29/99
21-50-03 (config 1) Page 3	21-50-03 (config 1) Page 3	01/29/99
21-50-03 (config 2) Page 1 thru Page 3	21-50-03 (config 2) Page 1 thru Page 3	01/29/99 01/29/99
21-50-03 (config 3) Page 1 thru Page 3	21-50-03 (config 3) Page 1 thru Page 3	01/29/99 01/29/99

Raytheon Aircraft
INSTRUCTION PAGES
REVISION 35-590102-9E1

REMOVE PAGES	INSERT PAGES	DATED
21-50-03 (config 4) Page 1 thru Page 3	21-50-03 (config 4) Page 1 thru Page 3	01/29/99 01/29/99
24-Contents Page 1 thru Page 3	24-Contents Page 1 thru Page 3	01/29/99 01/29/99
24-30-01 (config 1) Page 1 thru Page 5	24-30-01 (config 1) Page 1 thru Page 5	01/29/99 01/29/99
24-30-01 (config 2) Page 1 thru Page 5	24-30-01 (config 2) Page 1 thru Page 5	01/29/99 01/29/99
24-30-02 (config 1) Page 1 thru Page 5	24-30-02 (config 1) Page 1 thru Page 5	01/29/99 01/29/99
24-30-02 (config 2) Page 1 thru Page 5	24-30-02 (config 2) Page 1 thru Page 5	01/29/99 01/29/99
24-30-03 (Config 1) Page 1 thru Page 5	24-30-03 (config 1) Page 1 thru Page 5	01/29/99 01/29/99
24-30-03 (config 2) Page 1 thru Page 5	24-30-03 (config 2) Page 1 thru Page 5	01/29/99 01/29/99
24-30-04 (config 1) Page 1 thru Page 5	24-30-04 (config 1) Page 1 thru Page 5	01/29/99 01/29/99
24-30-04 (config 2) Page 1 thru Page 5	24-30-04 (config 2) Page 1 thru Page 5	01/29/99 01/29/99

Raytheon Aircraft
INSTRUCTION PAGES
REVISION 35-590102-9E1

REMOVE PAGES	INSERT PAGES	DATED
24-30-04 (config 3) Page 1 thru Page 5	24-30-04 (config 3) Page 1 thru Page 5	01/29/99 01/29/99
24-30-04 (config 4) Page 1 thru Page 5	24-30-04 (config 4) Page 1 thru Page 5	01/29/99 01/29/99
24-33-01 Page 1 thru Page 5	24-33-01 Page 1 thru Page 5	01/29/99 01/29/99
24-33-02 Page 1 thru Page 5	24-33-02 Page 1 thru Page 5	01/29/99 01/29/99
24-34-01 Page 1 thru Page 5	24-34-01 Page 1 thru Page 5	01/29/99 01/29/99
24-34-02 Page 1 thru Page 5	24-34-02 Page 1 thru Page 5	01/29/99 01/29/99
24-40-01 Page 3	24-40-01 Page 3	01/29/99
25-Contents Page 1	25-Contents Page 1	01/29/99
25-11-01 Page 3	25-11-01 Page 3	01/29/99
25-11-02 Page 3	25-11-02 Page 3	01/29/99
25-12-01 Page 3	25-12-01 Page 3	01/29/99
25-12-02 Page 3	25-12-02 Page 3	01/29/99
25-12-03 Page 3	25-12-03 Page 3	01/29/99

Raytheon Aircraft
INSTRUCTION PAGES
REVISION 35-590102-9E1

REMOVE PAGES	INSERT PAGES	DATED
32-Contents Page 1	32-Contents Page 1	01/29/99
32-30-01 (config 2) Page 3 thru Page 5	32-30-01 (Config 2) Page 3	01/29/99
32-30-02 (config 2) Page 3 thru Page 5	32-30-02 (config 2) Page 3	01/29/99
32-31-01 Page 1 thru Page 5	32-31-01 Page 1 thru Page 5	01/29/99 01/29/99
32-31-02 Page 1 thru Page 5	32-31-02 Page 1 thru Page 5	01/29/99 01/29/99
33-Contents Page 1 thru Page 3	33-Contents Page 1 thru Page 5	01/29/99 01/29/99
33-10-02 (config 2) Page 3	33-10-02 (config 2) Page 3	01/29/99
33-15-01 Page 1 thru Page 5	33-15-01 Page 1 thru Page 5	01/29/99 01/29/99
33-15-02 Page 1 thru Page 3	33-15-02 Page 1 thru Page 5	01/29/99 01/29/99
39-Contents Page 1	39-Contents Page 1	01/29/99
39-10-01 Page 3	39-10-01 Page 3	01/29/99
39-10-02 Page 3	39-10-02 Page 3	01/29/99

Raytheon Aircraft
INSTRUCTION PAGES
REVISION 35-590102-9E1

REMOVE PAGES	INSERT PAGES	DATED
39-10-03 Page 1 thru Page 3	39-10-03 Page 1 thru Page 5	01/29/99 01/29/99
39-10-10 Page 3	39-10-10 Page 3	01/29/99
39-10-20 Page 3	39-10-20 Page 3	01/29/99
39-10-30 Page 3	39-10-30 Page 3	01/29/99
39-10-40 Page 1 thru Page 3	39-10-40 Page 1 thru Page 5	01/29/99 01/29/99
39-10-41 Page 1 thru Page 3	39-10-41 Page 1 thru Page 3	01/29/99 01/29/99
91-Contents Page 1 Page 2	91-Contents Page 1 Page 2	01/29/99 01/29/99
91-01-01 Page 3	91-01-01 Page 3	01/29/99
91-01-02 Page 3	91-01-02 Page 3	01/29/99
91-03-01 Page 3	91-03-01 Page 3	01/29/99

BEECHCRAFT
BONANZA
WIRING DIAGRAM MANUAL

INTRODUCTION

LIST OF PAGE EFFECTIVITY

CHAPTER SECTION SUBJECT	PAGE	DATE
INTRODUCTION-EFFECTIVITY	1	OCT/95
INTRODUCTION	1	OCT/95
	thru	OCT/95
	10	OCT/95
ALPHABETICAL INDEX	1	OCT/95
	thru	OCT/95
	5	OCT/95

Beechcraft
BONANZA
WIRING DIAGRAM MANUAL

INTRODUCTION

NOTE

Service Publication reissues or revisions are not automatically provided to the holders of this manual. For information on how to obtain reissues or revisions applicable to this manual, refer to the latest revision of BEECHCRAFT Service Bulletin No. 2001.

WARNING

Use only genuine BEECHCRAFT or BEECHCRAFT approved parts obtained from BEECHCRAFT approved sources, in connection with the maintenance and repair of Beech airplanes.

Genuine BEECHCRAFT parts are produced and inspected under rigorous procedures to insure airworthiness and suitability for use in Beech airplane applications. Parts purchased from sources other than BEECHCRAFT, even though outwardly identical in appearance, may not have had the required tests and inspections performed, may be different in fabrication techniques and materials, and may be dangerous when installed in an airplane.

Salvaged airplane parts, reworked parts obtained from non-BEECHCRAFT approved sources, or parts, components, or structural assemblies, the service history of which is unknown or cannot be authenticated, may have been subjected to unacceptable stresses or temperatures or have other hidden damage, not discernible through routine visual or usual nondestructive testing techniques. This may render the part, component or structural assembly, even though originally manufactured by BEECHCRAFT, unsuitable and unsafe for airplane use.

BEECHCRAFT expressly disclaims any responsibility for malfunctions, failures, damage or injury caused by use of non-BEECHCRAFT approved parts.

NOTE

It shall be the responsibility of the owner/operator to ensure that the latest revisions of publications referenced in this handbook are utilized during operation, servicing, and maintenance of the airplane.

The BEECHCRAFT Bonanza Wiring Diagram Manual is prepared in accordance with the GAMA (General Aviation Manufacturers Association) Specification No. 2. It also meets the intent of the ATA (Air Transport Association of America) with respect to the arrangement and content of the system/chapters within the designated chapter numbering system.

This wiring diagram manual is supplemented by the following publications:

- BEECHCRAFT Bonanza 36 Series Shop Manual P/N 36-590001-3B
- BEECHCRAFT Bonanza Maintenance Manual P/N 36-590001-9A
- BEECHCRAFT Bonanza Parts Catalog P/N 33-590010-7F
- BEECHCRAFT Bonanza Parts Catalog P/N 35-590102-5E
- BEECHCRAFT Bonanza Parts Catalog P/N 36-590001-1G

NOTE

Beech Aircraft Corporation expressly reserves the right to supersede, cancel and/or declare obsolete any part, part numbers, kits or publication that may be referenced in this manual without prior notice.

CORRESPONDENCE

If a question should arise concerning the care of your airplane, it is important to include the airplane serial number in any correspondence. The serial number appears on the model designation placard on the cabin door frame.

Beechcraft BONANZA WIRING DIAGRAM MANUAL

ASSIGNMENT OF SUBJECT MATERIAL

The content of this publication is organized at four levels: Group, System/Chapter, Sub-System/Section, and Unit/Subject.

Group - Identified by different colored divider tabs. These are primary divisions of the manual that enable broad separation of content. Typical of this division is the separation between Airframe Systems and the Propeller.

System/Chapter - The various groups are broken down into major systems such as Environmental Systems, Electrical Power, Landing Gear, etc. The systems are arranged more or less alphabetically rather than by precedence or importance. They are assigned a number, which becomes the first element of a standardized numbering system. Thus the element "28" of the number 28-00-00 refers to the chapter "Fuel". Everything concerning the fuel system will be covered in this chapter.

Sub-System/Section - The major systems of an airplane are broken down into sub-systems. These sub-systems are identified by the second element of a standard numbering system. The number "40" of the number 28-40-00 is for the indicating portion of the fuel system.

Unit/Subject - The individual units within a sub-system may be identified by the third element of the standard numbering system, such as 28-40-01. This number is assigned by the manufacturer and may, or may not be used.

APPLICATION

Any publication conforming to this format will use the same basic numbering system. Thus whether the manual be a BEECHCRAFT Bonanza Maintenance Manual, or a BEECHCRAFT Bonanza Wiring Diagram Manual, the person wishing information concerning the indicating portion of the fuel system, would refer to the System/Chapter tab "28 FUEL". The Table of Contents in the front of this chapter will provide a list of sub-systems covered in this chapter.

For example:

28-00	General
28-10	Storage (Tanks, cells, necks, caps, instruments, etc.)

28-20	Distribution (Fuel lines, pumps, valves, Controls, ect.)
28-30	Dump (If in-flight dumping system is installed it would appear here.)
28-40	Indicating (Quantity, temperature, pressure, etc., does not include engine fuel flow or pressure.)

The material is arranged within the chapter in ascending numerical sequence. The Chapter-System Subject number and page number are found at the lower outside corner of each page.

LIST OF CHAPTERS NON-APPLICABLE TO THIS WIRING DIAGRAM MANUAL ARE INDICATED AS FOLLOWS:

04, 05, 06, 07, 08, 09, 10, 11, 12, 20, 22, 26, 29, 31, 35, 37, 38, 49, 51, 52, 53, 54, 55, 56, 57, 61, 71, 72, 75, 76, 78, 79, 80, 81 and 83.

CHAPTER SYSTEM INDEX GUIDE

The following is a GAMA Spec No. 2 Chapter System Index Guide to be used with this wiring diagram.

SYSTEM CHAPTER	SUB-SYSTEM SECTION
21 - ENVIRONMENTAL SYSTEMS	21-00-00
23 - COMMUNICATIONS	23-00-00
24 - ELECTRICAL POWER	24-00-00
25 - EQUIPMENT/FURNISHINGS	25-00-00
27 - FLIGHT CONTROLS	27-00-00
28 - FUEL	28-00-00
30 - ICE & RAIN PROTECTION	30-00-00
32 - LANDING GEAR	32-00-00
33 - LIGHTS	33-00-00
34 - NAVIGATION & PITOT/STATIC	34-00-00
36 - PNEUMATIC	36-00-00
39 - ELECTRIC PANELS, PARTS AND INSTRUMENTS	39-00-00
73 - ENGINE FUEL SYSTEMS	73-00-00
74 - IGNITION	74-00-00

Beechcraft
BONANZA
WIRING DIAGRAM MANUAL

(Continued)

SYSTEM CHAPTER	SUB-SYSTEM SECTION
77 - ENGINE INDICATING	77-00-00
91 - CHARTS	91-00-00

EFFECTIVITY

LIST OF EFFECTIVE REVISIONS

The List of Effective Revisions Page following the logo page of the manual lists the revisions currently effective for the manual.

RECORD OF REVISIONS

A Record of Revisions Page is provided following the List of Effective Revisions ("A") Page. When a revision is inserted, the revision number, the date the revision is inserted into the manual, and the initials of the person(s) inserting the revision should be recorded on this page.

LIST OF PAGES & TABLE OF CONTENTS

The List of Pages & Table of Contents following each Chapter Divider-Tab, lists the issue date of each page that is effective for that chapter, the titles and, if applicable, the effectivity of the circuits covered in that chapter.

SERIALIZATION

The effectivity of each wiring diagram and electrical component part, unless otherwise specified, is the same as the effectivity of the manual as given on the title page. If the effectivity of a wiring circuit is limited, the airplane serials for which the circuit is effective will be noted on the List of Pages & Table of Contents page as a configuration. Specific serial designations are listed at the end of the appropriate equipment list.

WIRING DIAGRAMS

To facilitate locating components and tracing the circuitry of individual diagrams, each wire is identified by the wire code it bears in the airplane. The individual circuit components are identified by a reference designator. Symbols used in the wiring diagrams appear, in figures 2 and 3, in the Introduction of this manual.

OPTIONAL EQUIPMENT

This manual does not in all cases differentiate between optional and standard equipment. In order to

facilitate the installation of certain wire harnesses used to connect optional equipment, these harnesses will be installed in all airplanes. Wires will be dead ended in airplanes that do not require the equipment.

EQUIPMENT LIST

A listing of the component parts accompanies each wiring diagram to aid maintenance personnel in ordering spare replacements. The components are listed in the order of alpha-numeric sequence of the reference designators.

The INSTL ZONE column of the equipment list designates the area of the airplane in which the component is located. A line drawing in the introduction provides a pictorial reference of these zones.

ALPHABETICAL INDEX

An Alphabetical Index, which may be found in the Introduction, is also provided as an assistance in locating the desired circuit. The Alphabetical Index provides the chapter and sub-chapter in which a circuit appears.

REFERENCE DESIGNATOR INDEX

The Reference Designator Index provides a cross reference listed by the reference designator to facilitate locating the component within this manual.

PART NUMBER INDEX

The Part Number Index provides a cross reference listed by the part number to facilitate locating the component within this manual.

MICROFICHE-AEROFICHE

This manual may be obtained in Aerofiche form from your local BEECHCRAFT Authorized Outlet.

REFERENCE DESIGNATORS

A reference designator is a combination of letters and numbers which identify a particular component in this wiring diagram manual. A reference designator is assigned to each component shown on the wiring schematics. Any component found in the schematic can be identified in the accompanying equipment list by its reference designator. An example of a reference designator follows:

CB 101 Is a reference designator for a circuit breaker.

Beechcraft BONANZA WIRING DIAGRAM MANUAL

101 Identifies it as a specific circuit breaker.

ASSEMBLIES-SUBASSEMBLIES

Assemblies are identified on the schematic by the reference designator and the assembly name. The accompanying equipment list displays the reference designator, part number and the assembly name. The reference designator of a component which belongs to an assembly begins with the reference designator of the assembly. A typical example follows:

A16 FLAP RELAY PC BOARD ASSEMBLY
A16K2 RELAY ASSEMBLY
A16K2P1 RELAY SOCKET

Assemblies can be purchased complete and ready for installation or they can be purchased by individual components. In some cases there are more components shown within the outline of an assembly than are actually part of the assembly. Assemblies should be ordered according to the equipment list since it will be more accurate in showing the components of the assemblies. Normally only electrical components are shown in the wiring diagram manual so there may be fasteners and other non-electrical components within an assembly which are not shown herein.

DELTA NOTES

The following "DELTA NOTE" will be found, where applicable, throughout the manual within the schematic:

- ▲1 Circuit breaker changes from PULL to PUSH-PULL on airplanes effective E-1766 THRU E-1945, E-1947 THRU E-2103, E-2105 THRU E-2110; CE-929 AND AFTER; CJ-156 AND AFTER; D-10354 AND AFTER; EA-159 THRU EA-319, EA-321 THRU EA-321.

WIRE CODES

The wire codes used in the BEECHCRAFT Bonanza Wiring Diagram Manual closely follow the military numbering system. Each wire and cable is identified by a combination of numbers and letters imprinted on the wire and cable as illustrated in figure 1. Each wire or cable is identified within 3 inches of each junction. No code is required for short wires or cables less than 3 inches in length. A non-metallic sleeve carrying

identification will appear on wires where imprinted codes cannot be affixed.

Circuit function letters indicate a relationship to a particular system (noted in the list of circuit function designations).

Wire numbers are provided to differentiate between wires in a circuit.

A wire segment is a conductor between two terminals or connections. Alphabetical sequence is usually followed. Wire segment "A" indicates the power source, "B" next segment, etc.

The wire size number is used to identify the size of the wire or cable.

A suffix to the wire identification code (N) identifies any wire or cable that completes the circuit to ground network.

Phase letter "A", "B", or "C", used as a suffix identifies three-phase wiring in AC systems.

The phase letter "V" is used as a suffix identifying an ungrounded wire or cable in a single phase system.

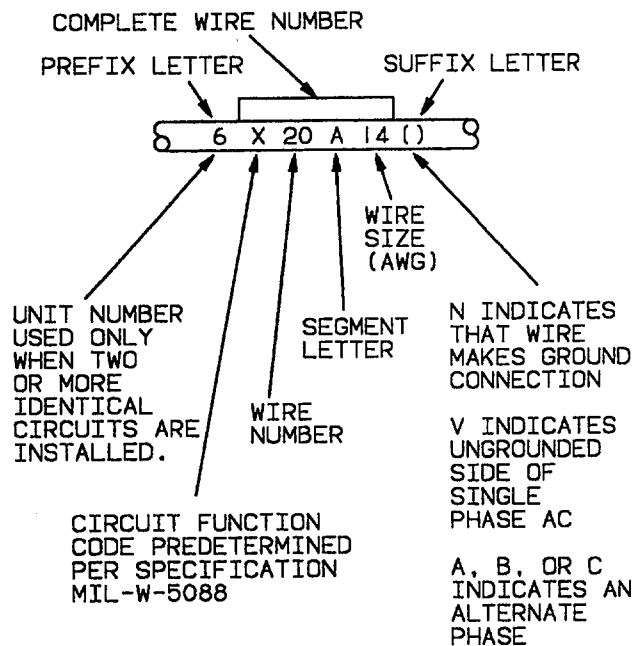

C94CE00F221/3 C

**Wire Codes
Figure 1**

Beechcraft BONANZA WIRING DIAGRAM MANUAL

For thermocouple wire, the following suffixes are applicable:

CHROM	Chromel
CONST	Constantan
ALME	Alumel
COP	Copper
IRON	Iron
ALUM	Aluminum

A list of Circuit Function Designations follows:

A	Armaments
B	Photographic
C	Control Surfaces; automatic pilot
D	Miscellaneous Instruments other than flight or engine instrument; ammeter, landing gear position, free air temperature, cabin pressure, etc.
E	Engine Instrument; fuel flow, fuel quantity, tachometer, synchroscope, etc.
F	Flight Instruments
G	Landing Gear; actuator, retraction, warning, down lock, etc.
H	Heating; ventilating, deicing,
J	Ignition
K	Engine Control; starter, prop synchronizer, etc.
L	Lighting
M	Miscellaneous Electrical; windshield wiper, etc.
P	DC power
Q	Fuel and Oil; fuel valves, fuel pump motors, throttle control, oil pumps, etc.
R	Radio; RC-radio command, RM-marker beacon, etc.

S	Radar; SA-altimeter, SS-search, etc.
T	Special electronics; TK-telemetry, TR-receivers, etc.
U	Miscellaneous electronics (other than R, S or T)
V	DC power for AC systems
W	Warning and Emergency
X	AC power
Y	Armaments special systems

GENERAL NOTES

- This is a point-to-point drawing only. Wire routing or parts callouts are not shown.
- Wires are connected on terminal boards and bus bars in the same positions shown schematically.
- The wiring diagrams contained herein are shown with aircraft power "OFF", control surfaces streamlined, and weight on the landing gear. Any deviation from the preceding conditions shall be so noted on the individual sheets.
- Use of an underline below a pin letter denotes a lower case letter. Example: A=a B=b etc.
- All connector inserts on charts are shown from the back of the connector.
- The abbreviation "BS" is used for "Bonding Strap".
- The abbreviation "M/W" is used for "Mates With".
- The abbreviation "WW" is used for "Wheel Well".
- The abbreviation "CONT'D" is used for "Continued".
- All components shown on a particular schematic may not be reflected on the accompanying equipment list. Only those components which apply to the specific chapter title are listed. To locate a component part number not listed with a specific schematic, refer to the Reference Designator Index for the chapter in which the component part number can be found.

Beechcraft
BONANZA
WIRING DIAGRAM MANUAL

APPROVED WIRE TYPES

Use only approved wire types when performing electrical maintenance or modification on the BEECH-CRAFT Bonanza. If replacement of a wire segment is required, use only wire of like type and size. If the type cannot be determined, contact the Customer Support Department of Beech Aircraft Corporation.

BEECH AIRCRAFT CORPORATION
9709 E. Central
PO Box 85
Wichita, KS 67201-0085
USA

Beechcraft BONANZA WIRING DIAGRAM MANUAL

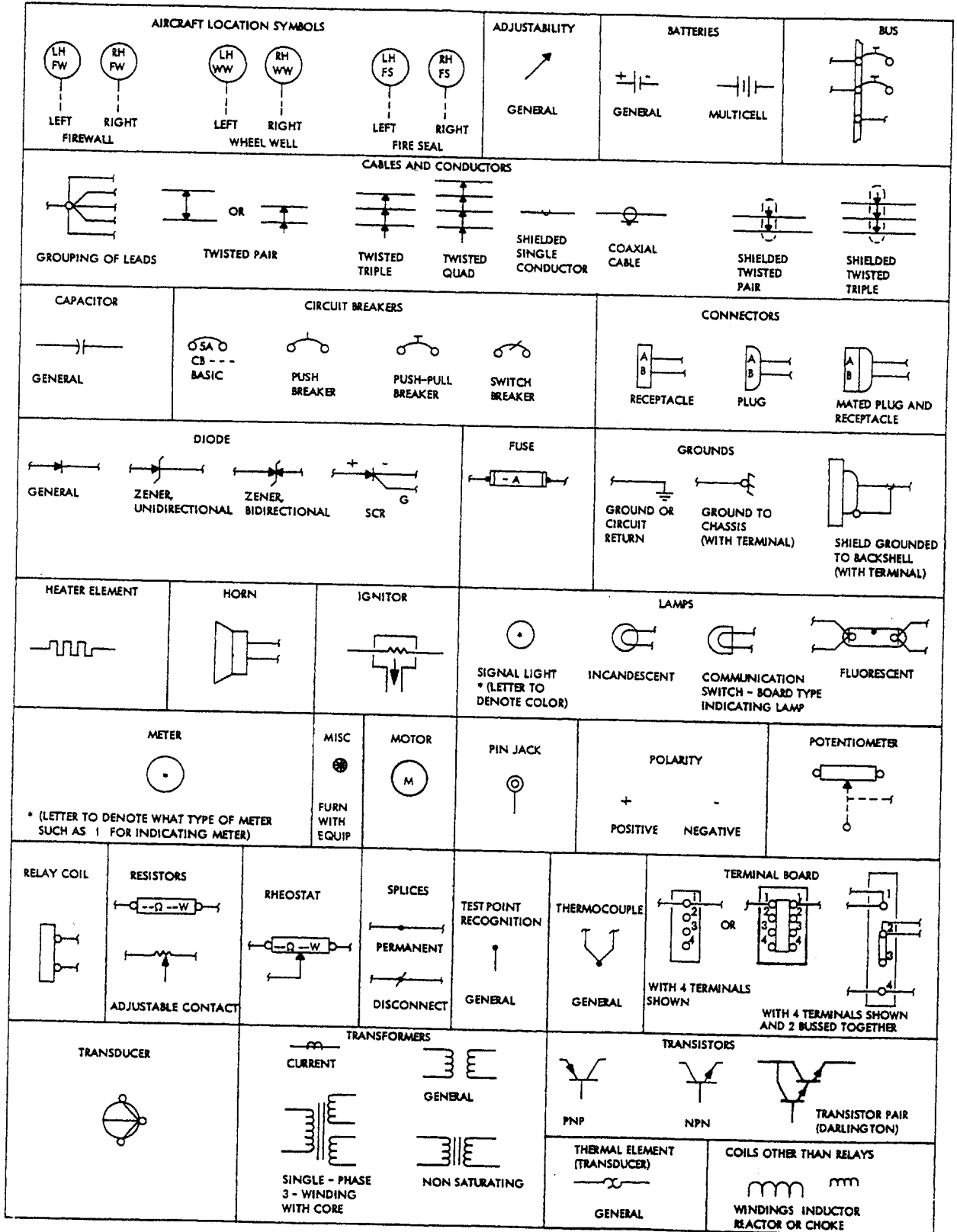

**Electrical Symbols
Figure 2**

Beechcraft BONANZA WIRING DIAGRAM MANUAL

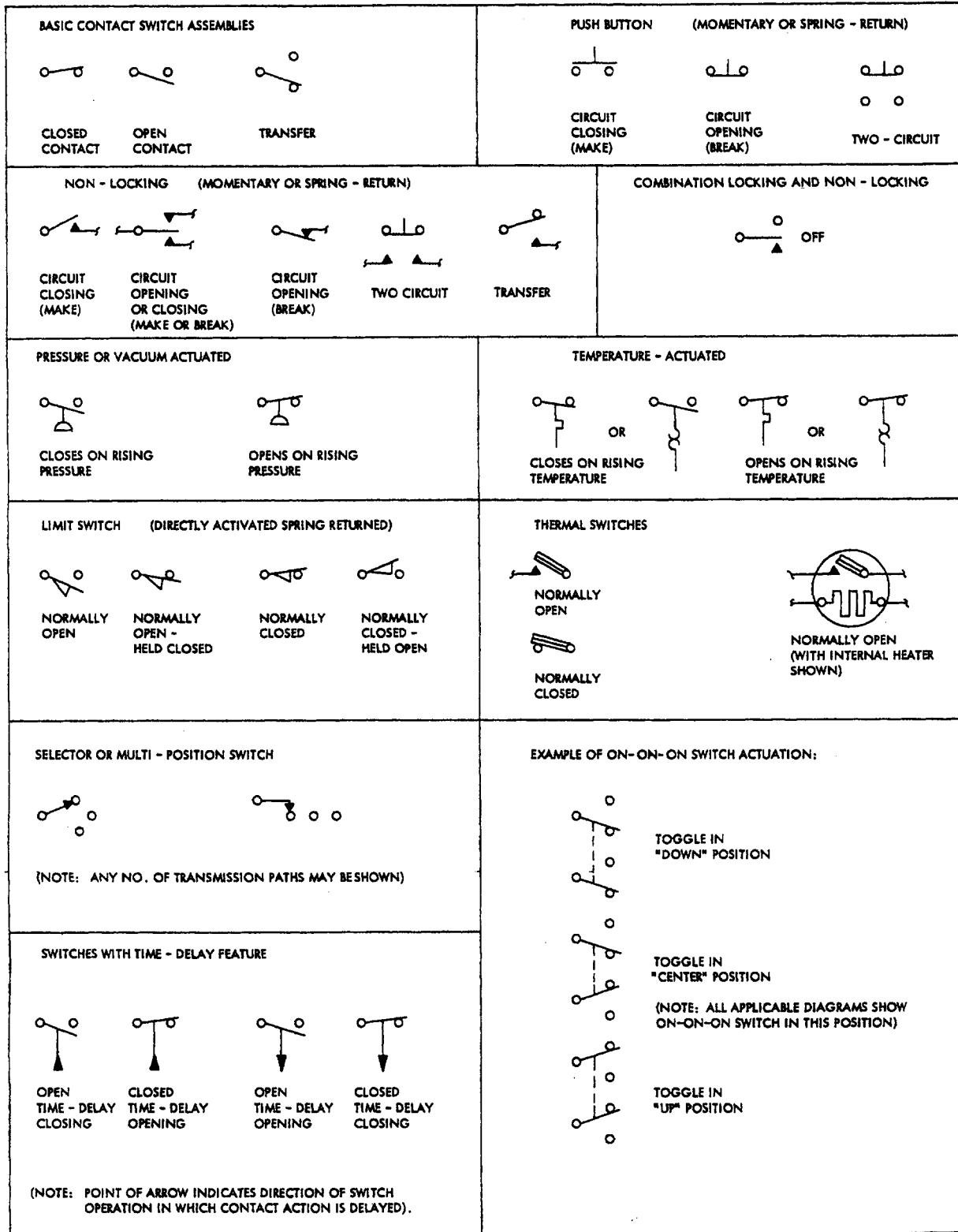

**Electrical Symbols
Figure 3**

Beechcraft
BONANZA
WIRING DIAGRAM MANUAL

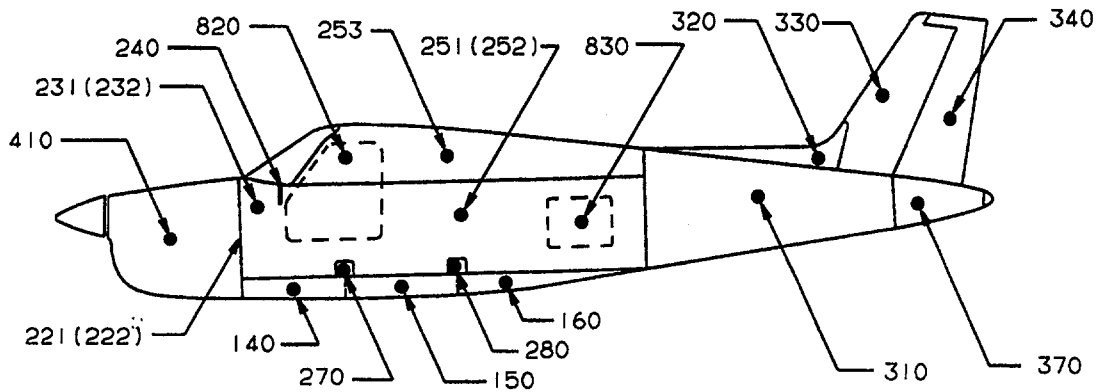

() INDICATES RIGHT SIDE

100 BELOW FLOOR

- 140 FIREWALL TO MAIN SPAR
- 150 MAIN SPAR TO REAR SPAR
- 160 AFT OF REAR SPAR

200 FORWARD FUSELAGE

- 221 (222) FIREWALL (ATTACHED TO OR ACCESSIBLE FROM FORWARD SIDE)
- 231 (232) FIREWALL TO INSTRUMENT PANEL
- 240 INSTRUMENT PANEL AND SUBPANEL
- 251 (252) CABIN (FLOOR LINE TO HEADLINER)
- 253 CABIN HEADLINER AREA
- 270 MAIN SPAR CARRY-THROUGH STRUCTURE
- 280 AFT SPAR CARRY-THROUGH STRUCTURE

300 AFT FUSELAGE AND EMPENNAGE

- 310 AFT FUSELAGE
- 320 DORSAL FIN (AIRCRAFT WITH CONVENTIONAL TAIL)
- 330 VERTICAL STABILIZER (AIRCRAFT WITH CONVENTIONAL TAIL)
- 340 RUDDER (AIRCRAFT WITH CONVENTIONAL TAIL)
- 370 TAIL CONE

410 ENGINE COMPARTMENT

800 DOORS

- 820 CABIN ENTRY DOOR
- 830 BAGGAGE OR CARGO DOOR

C95CJ00F3035 C

Aircraft Zone Diagram
Figure 4

**Beechcraft
BONANZA
WIRING DIAGRAM MANUAL**

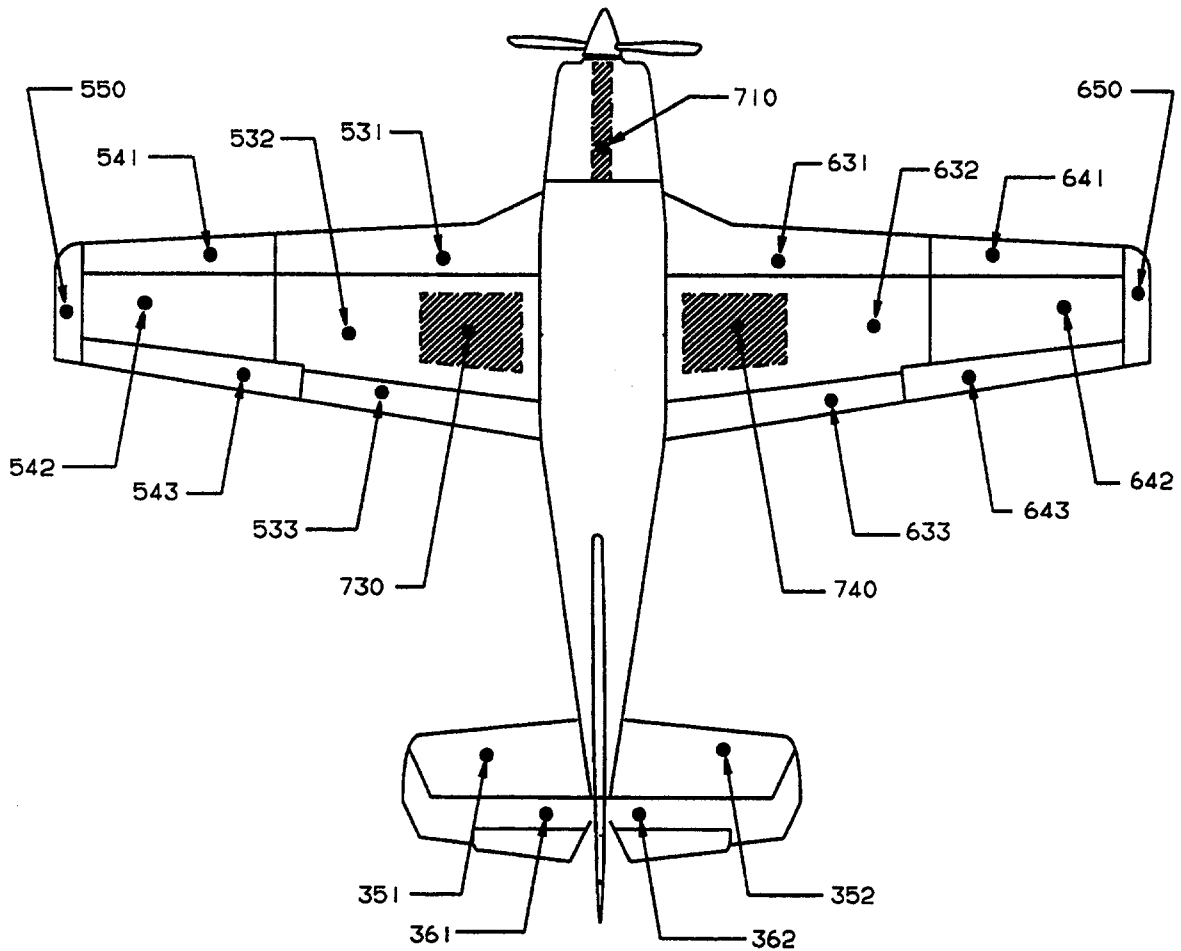

() INDICATES RIGHT SIDE

300 AFT FUSELAGE AND EMPENNAGE

351 (352) HORIZONTAL STABILIZER
361 (362) ELEVATOR

500 (600) WING AND CONTROL SURFACES

531 (631) WING, INBOARD LEADING EDGE
532 (632) WING, INBOARD-AFT OF MAIN SPAR
533 (633) FLAP
541 (641) WING, OUTBOARD-LEADING EDGE
542 (642) WING, OUTBOARD-AFT OF MAIN SPAR
543 (643) AILERON
550 (650) WING TIP

700 GEAR DOORS AND WHEELWELLS

710 NOSE LANDING GEAR
730 (740) MAIN LANDING GEAR

C95CJ00F3036 C

**Aircraft Zone Diagram
Figure 5**

ALPHABETICAL INDEX

Beechcraft
BONANZA
WIRING DIAGRAM MANUAL
ALPHABETICAL INDEX

COMPONENT ITEM OR SYSTEM NAME

CHAP/SUB SECT & UNIT

A

AIR CONDITIONING-COOLING (OPTIONAL)	21-50-01
AIR CONDITIONING-COOLING (OPTIONAL)	21-50-02
AIR CONDITIONING-COOLING (OPTIONAL)	21-50-03
AIR CONDITIONING-COOLING (OPTIONAL)	21-50-03
AIR CONDITIONING-COOLING (OPTIONAL)	21-50-03
AIR CONDITIONING-COOLING (OPTIONAL)	21-50-03
ALTERNATOR	24-30-04
ALTERNATOR	24-30-04
ALTERNATOR (AFTER INSTALLATION OF KIT 55-3025-1S)	24-30-01
ALTERNATOR (AFTER INSTALLATION OF KIT 55-3025-1S)	24-30-02
ALTERNATOR (AFTER INSTALLATION OF KIT 55-3025-1S)	24-30-03
ALTERNATOR (AFTER INSTALLATION OF KIT 55-3025-1S)	24-30-04
ALTERNATOR (PRIOR TO INSTALLATION OF KIT 55-3025-1S)	24-30-01
ALTERNATOR (PRIOR TO INSTALLATION OF KIT 55-3025-1S)	24-30-02
ALTERNATOR (PRIOR TO INSTALLATION OF KIT 55-3025-1S)	24-30-03
ALTERNATOR (PRIOR TO INSTALLATION OF KIT 55-3025-1S)	24-30-04
ANNUNCIATOR LIGHT JUNCTION BOX ASSEMBLY	91-02-01
ANNUNCIATOR LIGHT JUNCTION BOX ASSEMBLY	91-02-02
ANNUNCIATOR LIGHT JUNCTION BOX ASSEMBLY	91-02-03
ATTITUDE AND DIRECTION-STANDBY AIR PUMP GYRO	34-22-01
ATTITUDE AND DIRECTION-TURN COORDINATOR	34-20-01

B

BLOWER-FRESH AIR VENT (OPTIONAL)	21-52-01
BLOWER-FRESH AIR VENT (OPTIONAL)	21-52-01

C

CABIN SPEAKERS	23-50-01
CIGARETTE LIGHTER	25-10-01
CIGARETTE LIGHTER	25-10-02
CIGARETTE LIGHTER	25-10-03
CLOCK, CONTROL WHEEL DIGITAL (OPTIONAL)	25-12-01
CLOCK, CONTROL WHEEL DIGITAL (OPTIONAL)	25-12-02
CLOCK, CONTROL WHEEL DIGITAL (OPTIONAL)	25-12-03
CLOCK, DIGITAL PANEL	25-11-02
CLOCK, PANEL	25-11-01
CONNECTOR-GLARESHIELD (P/J31)	91-22-01
CONNECTOR-INSTRUMENT PANEL GROUNDING (P/J80)	91-15-01
CONNECTOR-INSTRUMENT PANEL GROUNDING (P/J80)	91-15-02
CONNECTOR-WHEEL WELL ACCESS, LEFT WING (P/J10)	91-12-01
CONNECTOR-WHEEL WELL ACCESS, LEFT WING (P/J10)	91-12-02
CONNECTOR-WHEEL WELL ACCESS, LEFT WING (P/J10)	91-12-02
CONNECTOR-WHEEL WELL ACCESS, RIGHT WING (P/J11)	91-13-01
CROSSOVER DISCONNECT (P/J85)	91-21-01

Beechcraft
BONANZA
WIRING DIAGRAM MANUAL
ALPHABETICAL INDEX (CONTINUED)

Courtesy of Bomar Flying Service
www.bomar.biz

COMPONENT ITEM OR SYSTEM NAME	CHAP/SUB SECT & UNIT
CROSSOVER DISCONNECT (P/J85)	91-21-01

E

ELECTRICAL EQUIPMENT JUNCTION BOX	91-01-01
ELECTRICAL EQUIPMENT JUNCTION BOX	91-01-02
ELEVATOR TRIM (OPTIONAL)	27-32-01

F

FLAPS-MOTOR	27-50-01
FLAPS-MOTOR	27-50-02
FLAPS-MOTOR	27-50-02
FLAPS-POSITION INDICATOR	27-51-01
FLAPS-POSITION INDICATOR	27-51-02
FUEL PUMP-AUXILIARY	28-20-01
FUEL PUMP-AUXILIARY	28-20-02
FUEL PUMP-AUXILIARY	28-20-03
FUEL PUMP-AUXILIARY	28-20-03
FUEL PUMP-AUXILIARY	28-20-03
FUEL PUMP-AUXILIARY	28-20-04
FUEL PUMP-AUXILIARY	28-20-05

I

IGNITION-SWITCHING	74-30-01
IGNITION-SWITCHING	74-30-02
INDICATING SYSTEM-TURBINE INTAKE TEMPERATURE SYSTEM	77-30-01
INDICATING-FUEL FLOW SYSTEM	73-30-01
INDICATING-FUEL QUANTITY	28-40-01
INDICATING-FUEL QUANTITY	28-40-02
INDICATING-FUEL QUANTITY	28-40-03
INDICATING-FUEL QUANTITY	28-40-04
INDICATING-FUEL QUANTITY	28-40-05
INDICATING-STANDBY INSTRUMENT AIR PRESSURE KIT (36-5009-3P)	36-20-02
INDICATING-STANDBY INSTRUMENT AIR PRESSURE KIT (36-5011-3P)	36-20-02

J

JUNCTION BOX DISCONNECT (P/J54)	91-19-01
JUNCTION BOX DISCONNECT (P/J54)	91-19-02
JUNCTION BOX DISCONNECT (P/J54)	91-19-03
JUNCTION BOX DISCONNECT (P/J54)	91-19-03

ALPHABETICAL INDEX

PAGE 2

OCT/95

Beechcraft
BONANZA
WIRING DIAGRAM MANUAL
ALPHABETICAL INDEX (CONTINUED)

COMPONENT ITEM OR SYSTEM NAME

CHAP/SUB SECT & UNIT

L

LANDING GEAR SAFETY SYSTEM RELAY ASSEMBLY (OPTIONAL)	91-03-01
LANDING GEAR-MOTOR AND RELAY	32-30-01
LANDING GEAR-MOTOR AND RELAY	32-30-01
LANDING GEAR-MOTOR AND RELAY	32-30-02
LANDING GEAR-MOTOR AND RELAY	32-30-02
LANDING GEAR-POSITION INDICATOR	32-60-01
LANDING GEAR-POSITION INDICATOR	32-60-01
LANDING GEAR-SAFETY SYSTEM (OPTIONAL)	32-31-01
LANDING GEAR-SAFETY SYSTEM (OPTIONAL)	32-31-02
LIGHTS-ANNUNCIATOR TEST, FLIGHT COMPARTMENT	33-10-02
LIGHTS-ANNUNCIATOR TEST, FLIGHT COMPARTMENT	33-10-02
LIGHTS-ANNUNCIATOR TEST, FLIGHT COMPARTMENT	33-10-02
LIGHTS-ANNUNCIATOR, FLIGHT COMPARTMENT	33-10-01
LIGHTS-CABIN	33-20-01
LIGHTS-CABIN	33-20-02
LIGHTS-COURTESY (OPTIONAL)	33-42-01
LIGHTS-DIMMING	33-15-01
LIGHTS-DIMMING	33-15-02
LIGHTS-ELECTROLUMINOUS PANEL	33-16-01
LIGHTS-ENGINE INSTRUMENT WEDGE (OPTIONAL)	33-12-01
LIGHTS-ENGINE INSTRUMENT WEDGE (OPTIONAL)	33-12-02
LIGHTS-ENGINE INSTRUMENT WEDGE (OPTIONAL)	33-12-03
LIGHTS-FLIGHT INSTRUMENT WEDGE (OPTIONAL)	33-14-01
LIGHTS-FLIGHT INSTRUMENT WEDGE (OPTIONAL)	33-14-02
LIGHTS-FLIGHT INSTRUMENT WEDGE (OPTIONAL)	33-14-03
LIGHTS-FLIGHT INSTRUMENTS POST (OPTIONAL)	33-17-01
LIGHTS-FLIGHT INSTRUMENTS POST (OPTIONAL)	33-17-02
LIGHTS-FLIGHT INSTRUMENTS POST (OPTIONAL)	33-17-03
LIGHTS-FLOOD	33-18-01
LIGHTS-FLOOD	33-18-01
LIGHTS-LANDING	33-46-01
LIGHTS-MAP, COMPASS, OAT AND FUEL SELECT	33-11-01
LIGHTS-MAP, COMPASS, OAT AND FUEL SELECT	33-11-02
LIGHTS-MAP, COMPASS, OAT AND FUEL SELECT	33-11-02
LIGHTS-NAVIGATION	33-45-01
LIGHTS-NAVIGATION	33-45-01
LIGHTS-RADIO AND ENGINE INSTRUMENT	33-13-01
LIGHTS-RADIO AND ENGINE INSTRUMENT	33-13-02
LIGHTS-RADIO AND ENGINE INSTRUMENT POST	33-13-03
LIGHTS-ROTATING BEACON (OPTIONAL)	33-44-01
LIGHTS-ROTATING BEACON (OPTIONAL)	33-44-02
LIGHTS-ROTATING BEACON (OPTIONAL)	33-44-02
LIGHTS-ROTATING BEACON (OPTIONAL)	33-44-02
LIGHTS-TAXI	33-43-01
LIGHTS-THREE LIGHT STROBE (OPTIONAL)	33-40-01
LIGHTS-THREE LIGHT STROBE (OPTIONAL)	33-40-02
LIGHTS-THREE LIGHT STROBE (OPTIONAL)	33-40-02

Beechcraft
BONANZA
WIRING DIAGRAM MANUAL
ALPHABETICAL INDEX (CONTINUED)

COMPONENT ITEM OR SYSTEM NAME

CHAP/SUB SECT & UNIT

M

MICROPHONE SWITCH 23-01-01

P

PITOT-HEATED (OPTIONAL) 30-30-01
 PITOT-HEATED (OPTIONAL) 30-30-02
 POSITION AND WARNING-THROTTLE AND AIRSPEED 32-60-02
 POWER-EMERGENCY, DUAL NAVIGATION/COMMUNICATIONS (OPTIONAL) 24-33-01
 POWER-EMERGENCY, DUAL NAVIGATION/COMMUNICATIONS (OPTIONAL) 24-33-02
 POWER-EMERGENCY, DUAL NAVIGATION/COMMUNICATIONS (OPTIONAL) 24-51-01
 POWER-EMERGENCY, DUAL NAVIGATION/COMMUNICATIONS (OPTIONAL) 24-51-02
 POWER-EMERGENCY, DUAL NAVIGATION/COMMUNICATIONS (OPTIONAL) 24-51-02
 POWER-EMERGENCY, SINGLE NAVIGATION/COMMUNICATIONS (OPTIONAL) 24-34-01
 POWER-EMERGENCY, SINGLE NAVIGATION/COMMUNICATIONS (OPTIONAL) 24-34-02
 POWER-EMERGENCY, SINGLE NAVIGATION/COMMUNICATIONS (OPTIONAL) 24-52-01
 POWER-EMERGENCY, SINGLE NAVIGATION/COMMUNICATIONS (OPTIONAL) 24-52-02
 POWER-EMERGENCY, SINGLE NAVIGATION/COMMUNICATIONS (OPTIONAL) 24-52-02
 POWER-EXTERNAL 24-40-01
 PRINTED CIRCUIT BOARD ASSEMBLY-ANNUNCIATOR LIGHT (58-364055-1) 39-10-01
 PRINTED CIRCUIT BOARD ASSEMBLY-ANNUNCIATOR LIGHT (58-364055-7) 39-10-02
 PRINTED CIRCUIT BOARD ASSEMBLY-ANNUNCIATOR LIGHT (58-364055-9) 39-10-03
 PRINTED CIRCUIT BOARD ASSEMBLY-ELECTRICAL EQUIPMENT (002-364038-1) 39-10-30
 PRINTED CIRCUIT BOARD ASSEMBLY-FLAP POSITION (002-364040-1) 39-10-20
 PRINTED CIRCUIT BOARD ASSEMBLY-FUEL QUANTITY INDICATOR (58-364058-13) 39-10-41
 PRINTED CIRCUIT BOARD ASSEMBLY-FUEL QUANTITY INDICATOR (58-364058-3) 39-10-40
 PRINTED CIRCUIT BOARD ASSEMBLY-LEFT FUEL QUANTITY INDICATOR (58-364041-9) 39-10-10
 PROPELLERS ANTI-ICE (OPTIONAL) 30-60-01
 PROPELLERS ANTI-ICE (OPTIONAL) 30-60-01

S

STALL WARNING 27-31-01
 STALL WARNING 27-31-02
 STALL WARNING 27-31-02
 SUBPANEL-LEFT AND RIGHT 24-50-02
 SUBPANEL-LEFT AND RIGHT 24-50-02
 SUBPANELS-LEFT AND RIGHT 24-50-01

T

TEMPERATURE-ENGINE INSTRUMENT CLUSTER 77-20-01
 TRANSMITTER-EMERGENCY LOCATOR 25-60-01

ALPHABETICAL INDEX

PAGE 4

OCT/95

Beechcraft
BONANZA
WIRING DIAGRAM MANUAL
ALPHABETICAL INDEX (CONTINUED)

COMPONENT ITEM OR SYSTEM NAME

CHAP/SUB SECT & UNIT

V

VOLTAGE REGULATOR 24-31-01

**REFERENCE
DESIGNATOR
INDEX**

Raytheon Aircraft

BEECH BONANZA WIRING DIAGRAM MANUAL

REFERENCE DESIGNATOR INDEX

LIST OF PAGE EFFECTIVITY

SECTION	PAGE	DATE
REFERENCE DESIGNATOR INDEX - EFFECTIVITY	1	01/29/99
REFERENCE DESIGNATOR INDEX	1 thru 38	01/29/99 01/29/99

Raytheon Aircraft

BEECH BONANZA WIRING DIAGRAM MANUAL

REFERENCE DESIGNATOR INDEX

Reference Designator	GAMA/ATA Code	Part Number
AB	33-44-02	36-364030-39
AB	33-44-02	36-364030-43
AB	33-44-02	36-364030-7
AB	33-44-02	36-364030-37
AB	33-44-02	36-364030-45
AB	33-44-02	36-364030-5
AB	33-44-02	96-364078-7
AB	33-44-02	36-364030-5
AB	33-44-02	36-364030-39
AB	33-44-02	36-364030-43
AB	33-44-02	36-364030-7
AB	33-44-02	36-364030-37
AB	33-44-02	36-364030-45
AB	33-44-02	96-364078-7
AB	33-44-02	96-364078-7
AB	33-44-02	36-364030-1
AB	33-44-02	36-364030-7
AB	33-44-02	36-364030-37
AB	33-44-02	36-364030-45
A1	28-20-03	36-9008-1S
A1	36-20-02	36-5009-3P
A1	36-20-02	36-5011-3P
A10	32-30-01	58-364056-15
A10	32-30-02	58-364056-15
A10	91-02-01	58-364056-1
A10	91-02-02	58-364056-13
A10	91-02-03	58-364056-15
A10A1	32-30-01	58-364056-9
A10A1	32-30-02	58-364056-9
A10A1	39-10-03	58-364055-9
A10A1	91-02-01	58-364056
A10A1	91-02-02	58-364056-1
A10A1	91-02-03	58-364055-7
A10A1A1	39-10-01	58-364055-1
A10A1A1	39-10-02	58-364055-7
A10A1A1	91-02-01	58-364055-1
A10A1A1	91-02-02	58-364055-1
A10A1A1CR1	39-10-01	1N4734A
A10A1A1CR1	39-10-01	1N4734
A10A1A1CR1	39-10-01	132409-31
A10A1A1CR1	39-10-02	1N4734A
A10A1A1CR1	39-10-02	1N4734
A10A1A1CR1	39-10-02	132409-31
A10A1A1CR2	39-10-01	1N4007
A10A1A1CR2	39-10-01	132408-22
A10A1A1CR2	39-10-02	1N4007
A10A1A1CR2	39-10-02	132408-22
A10A1A1K2	39-10-01	50-384112-1
A10A1A1K2	39-10-02	50-384112-1
A10A1A1R1	39-10-01	RCR42G361KS
A10A1A1R1	39-10-01	RCR42G361JS
A10A1A1R1	39-10-01	132371E3600EFA
A10A1A1R1	39-10-02	RCR42G361KS
A10A1A1R1	39-10-02	RCR42G361JS
A10A1A1R2	39-10-01	RT22CW202
A10A1A1R2	39-10-02	RT22CW202
A10A1A1R3	39-10-01	RCR20G562KS
A10A1A1R3	39-10-01	RCR20G562JS

Reference Designator	GAMA/ATA Code	Part Number
A10A1A1R3	39-10-01	132371C5601EBC
A10A1A1R3	39-10-02	RCR20G562KS
A10A1A1R3	39-10-02	RCR20G562JS
A10A1A1R3	39-10-02	132371C5601EBC
A10A1A1R6	39-10-01	RCR42G151JS
A10A1A1R6	39-10-01	RCR42G151KS
A10A1A1R6	39-10-01	132371E1500EFA
A10A1A1R6	39-10-02	RCR42G151JS
A10A1A1R6	39-10-02	RCR42G151KS
A10A1A1R6	39-10-02	132371E1500EFA
A10A1A1R7	39-10-01	RCR20G511KS
A10A1A1R7	39-10-01	RCR20G511JS
A10A1A1R7	39-10-01	132371C5100EBC
A10A1A1R7	39-10-02	RCR20G511KS
A10A1A1R7	39-10-02	RCR20G511JS
A10A1A1R7	39-10-02	132371C5100EBC
A10A1A1W1	39-10-01	58-364054-1
A10A1CR1	39-10-03	1N4734A
A10A1CR1	39-10-03	132409-31
A10A1CR18	32-30-01	1N4007
A10A1CR18	32-30-01	132408-22
A10A1CR18	32-30-02	1N4007
A10A1CR18	32-30-02	132408-22
A10A1CR2	39-10-03	1N4007
A10A1CR2	39-10-03	132408-22
A10A1CR27	39-10-03	1N4742A
A10A1CR27	39-10-03	132409-37
A10A1C1	39-10-03	CSR13G106KM
A10A1C1	39-10-03	132391C10R00FNU
A10A1C2	39-10-03	CSR13G105KM
A10A1C2	39-10-03	132391A1R000FNU
A10A1C3	39-10-03	CKR05BX103KR
A10A1C3	39-10-03	132389C103EHM
A10A1DS1	91-02-01	R102
A10A1DS1	91-02-02	R102
A10A1GS1	91-02-01	131270-3
A10A1GS1	91-02-02	131270-3
A10A1K1	32-30-01	50-384112-1
A10A1K1	32-30-02	50-384112-1
A10A1K1	39-10-03	50-384112-1
A10A1LS1	91-02-01	169-380021-9
A10A1LS1	91-02-02	169-380021-9
A10A1LS2	91-02-01	169-380021-11
A10A1LS2	91-02-02	169-380021-11
A10A1Q1	39-10-03	2N5681
A10A1Q1	39-10-03	132404-26
A10A1Q2	39-10-03	2N5195
A10A1Q2	39-10-03	132404-21
A10A1R1	39-10-03	RCR42G361JS
A10A1R1	39-10-03	132371E3600EFA
A10A1R14	91-02-01	1717
A10A1R14	91-02-02	1717
A10A1R15	39-10-03	RNR60C5113FR
A10A1R15	39-10-03	132373G5113DBB
A10A1R16	39-10-03	RLR07C4701GS
A10A1R16	39-10-03	132371B4701EBC
A10A1R18	39-10-03	RLR07C1002GS
A10A1R18	39-10-03	132371B1002EBC

Raytheon Aircraft

BEECH BONANZA WIRING DIAGRAM MANUAL

REFERENCE DESIGNATOR INDEX (CONTINUED)

Reference Designator	GAMA/ATA Code	Part Number
A19R1	91-01-01	1 3/4D48F40
A19R1	91-01-02	1 3/4D48F40
A21	33-15-01	002-364042-35
A21	33-15-02	002-364042-35
A21MG1	33-15-01	58-380101-1
A21MG1	33-15-02	58-380101-1
A21Q1	33-15-02	2N3055H
A21Q1	33-15-02	132404-11
A21Q1A	33-15-01	2N3055
A21Q1B	33-15-01	132404-42
A21Q1C	33-15-01	2N3055H
A21Q1C	33-15-01	132404-11
A21Q2	33-15-02	2N3055H
A21Q2	33-15-02	132404-11
A21Q2A	33-15-01	2N3055
A21Q2B	33-15-01	132404-42
A21Q2C	33-15-01	2N3055H
A21Q2D	33-15-01	132404-11
A21Q3	33-15-02	2N3055H
A21Q3	33-15-02	132404-11
A21Q3A	33-15-01	2N3055
A21Q3B	33-15-01	132404-42
A21Q3C	33-15-01	2N3055H
A21Q3D	33-15-01	132404-11
A21Q4	33-15-02	2N3055H
A21Q4	33-15-02	132404-11
A21Q4A	33-15-01	2N3055
A21Q4B	33-15-01	132404-42
A21Q4C	33-15-01	2N3055H
A21Q4D	33-15-01	132404-11
A21R1	33-15-01	RCR42G680JS
A21R1	33-15-01	132371E68R0EFA
A21R1	33-15-02	RCR42G680JS
A21R1	33-15-02	132371E68R0EFA
A21R2	33-15-01	RCR42G680JS
A21R2	33-15-01	132371E68R0EFA
A21R2	33-15-02	RCR42G680JS
A21R2	33-15-02	132371E68R0EFA
A21R3	33-15-01	RCR42G680JS
A21R3	33-15-01	132371E68R0EFA
A21R3	33-15-02	RCR42G680JS
A21R3	33-15-02	132371E68R0EFA
A21R4	33-15-01	RCR42G680JS
A21R4	33-15-01	132371E68R0EFA
A21R4	33-15-02	RCR42G680JS
A21R4	33-15-02	132371E68R0EFA
A22	21-50-01	36-380021-27
A22	21-50-02	36-380021-27
A22	21-50-03	36-380021-27
A22	21-50-03	36-380021-27
A22	21-50-03	36-380021-27
A22	21-50-03	36-380021-33
A22	21-50-03	36-380021-27
A23	91-03-01	58-364061-1
A23CR1	91-03-01	1N4007
A23CR1	91-03-01	132408-22
A23CR2	91-03-01	1N4007
A23CR2	91-03-01	132408-22

Reference Designator	GAMA/ATA Code	Part Number
A23CR3	91-03-01	1N5404
A23K1	91-03-01	50-380048-11
A23K2	91-03-01	50-384112-1
A27	28-40-04	58-364058-3
A27	28-40-04	58-364058-13
A27	28-40-05	58-364058-13
A27/A28	39-10-40	58-364058-3
A27/A28	39-10-41	58-364058-13
A27J1	28-40-04	207378-1
A27J1	28-40-05	207378-1
A28	28-40-04	58-364058-3
A28	28-40-04	58-364058-13
A28	28-40-05	58-364058-3
A28J1	28-40-04	207378-1
A28J1	28-40-05	207378-1
A35R1	24-30-04	WF2K10R
A35SP1	24-30-04	D426-36
A35SP2	24-30-04	D426-37
BS1	27-51-01	MS25083-1BA6
BS1	27-51-02	MS25083-1BA6
BT10	24-30-01	36-380059-1
BT10	24-30-01	PS12-11
BT10	24-30-01	36-380059-1
BT10	24-30-01	PS12-11
BT10	24-30-02	36-380059-1
BT10	24-30-02	PS12-11
BT10	24-30-02	36-380059-1
BT10	24-30-02	PS12-11
BT10	24-30-03	36-380059-1
BT10	24-30-03	PS12-11
BT10	24-30-03	36-380059-1
BT10	24-30-03	PS12-11
BT10	24-30-04	36-380059-1
BT10	24-30-04	PS12-11
BT10	24-30-04	36-380059-1
BT10	24-30-04	PS12-11
BT10	24-30-04	36-380059-1
BT10	24-30-04	PS12-11
BT10	24-30-04	36-380059-1
B11	28-20-01	1296-00-1
B11	28-20-02	1296-00-1
B11	28-20-04	1296-00-1
B11	28-20-05	1296-00-1
B12	28-20-02	1297-00-1
B12	28-20-05	1297-00-1
B13	28-20-03	2B7-34
B13	28-20-03	2B7-34
B13	28-20-03	2B7-34
B15	24-30-01	MHJ-4003
B15	24-30-01	637847
B15	24-30-01	MHJ-4003
B15	24-30-01	637847
B15	24-30-02	MHJ-4003
B15	24-30-02	637847
B15	24-30-02	MHJ-4003
B15	24-30-02	637847
B15	24-30-03	MHJ-4003

Raytheon Aircraft

BEECH BONANZA WIRING DIAGRAM MANUAL

REFERENCE DESIGNATOR INDEX (CONTINUED)

Reference Designator	GAMA/ATA Code	Part Number
B15	24-30-03	637847
B15	24-30-03	MHJ-4003
B15	24-30-03	637847
B15	24-30-04	637847
B15	24-30-04	MHJ-4003
B15	24-30-04	637847
B15	24-30-04	MHJ-4003
B15	24-30-04	637847
B15	24-30-04	MHJ-4003
B15	24-30-04	MHJ-4003
B15	24-30-04	637847
B16A	27-32-01	33-524023-31
B16A	27-32-01	33-524023-33
B16B	27-32-01	50-380125
B16B	27-32-01	50-380125
B16C	27-32-01	319A209-4
B16C	27-32-01	319A209-1
B19	21-52-01	169-380096-5
B19	21-52-01	58-380108-1
B21	32-30-01	58-380090-5
B21	32-30-01	96-380022-5
B21	32-30-01	58-380090-5
B21	32-30-02	58-380090-5
B21	32-30-02	58-380090-5
B21	32-31-01	58-380090-5
B21	32-31-01	96-380022-5
B21	32-31-02	58-380090-5
B22	27-50-01	D160-00-3
B22	27-50-02	D160-00-3
B22	27-50-02	D160-00-3
B24	21-50-01	36-380027-29
B24	21-50-02	36-380027-29
B24	21-50-03	36-380027-29
B24	21-50-03	36-380027-29
B24	21-50-03	36-380027-29
B24	21-50-03	36-380027-37
B24	21-50-03	36-380027-29
B25	34-22-01	EM917-2
B25	36-20-02	EM917-5
B25	36-20-02	EM917-5
CB12	24-50-01	435-205-104
CB12	24-50-02	7277-2-5
CB12	24-50-02	7277-2-5
CB12	24-51-01	435-205-104
CB12	24-51-02	435-205-104
CB12	24-51-02	435-205-104
CB12	24-52-01	435-205-104
CB12	24-52-02	7277-2-5
CB12	24-52-02	7277-2-5
CB12	27-31-01	435-205-104
CB12	27-31-02	435-205-104
CB12	27-31-02	7277-2-5
CB12	27-31-02	7277-2-5
CB13	24-50-01	435-205-104
CB13	24-51-01	435-205-104
CB13	24-52-01	435-205-104
CB13	24-52-02	7277-2-5
CB13	24-52-02	7277-2-5

Reference Designator	GAMA/ATA Code	Part Number
CB13	32-31-01	7277-2-5
CB13	32-31-01	435-205-104
CB14	24-50-01	435-205-104
CB14	24-50-02	7277-2-10
CB14	24-50-02	7277-2-10
CB14	24-51-01	435-205-104
CB14	24-51-02	7277-2-10
CB14	24-51-02	7277-2-10
CB14	24-52-01	435-205-104
CB14	24-52-02	7277-2-10
CB14	24-52-02	7277-2-10
CB14	25-10-01	435-205-104
CB14	25-10-02	435-205-104
CB14	25-10-02	7277-2-5
CB14	25-10-03	435-205-104
CB14	25-10-03	7277-2-5
CB15	24-31-01	35-380132-13
CB15	24-50-01	35-380132-13
CB15	24-50-02	35-380132-13
CB15	24-50-02	35-380132-13
CB15	24-51-01	35-380132-13
CB15	24-51-02	35-380132-13
CB15	24-51-02	35-380132-13
CB15	24-52-01	35-380132-13
CB15	24-52-02	35-380132-13
CB15	24-52-02	35-380132-13
CB16	24-50-01	435-205-104
CB16	24-50-02	7277-2-5
CB16	24-51-01	435-205-104
CB16	24-51-02	435-205-104
CB16	24-51-02	435-205-104
CB16	24-52-01	435-205-104
CB16	24-52-02	7277-2-5
CB16	24-52-02	7277-2-5
CB16	25-11-01	435-205-104
CB16	25-11-01	7277-2-5
CB16	25-11-02	435-205-104
CB16	25-11-02	7277-2-5
CB16	25-12-01	435-205-104
CB16	25-12-02	435-205-104
CB16	25-12-03	435-205-104
CB16	25-12-03	7277-2-5
CB16	27-50-02	435-205-104
CB16	27-50-02	7277-2-5
CB16	27-50-02	7277-2-5
CB16	27-51-01	435-205-104
CB16	27-51-02	435-205-104
CB16	27-51-02	7277-2-5
CB16	33-11-02	435-205-104
CB16	33-11-02	7277-2-5
CB16	33-11-02	7277-2-5
CB17	24-50-01	435-215-104
CB17	24-50-02	7271-8-15
CB17	24-50-02	7271-8-15
CB17	24-51-01	435-215-104
CB17	24-51-02	435-215-104
CB17	24-51-02	435-215-104
CB17	24-52-01	435-215-104

Raytheon Aircraft

BEECH BONANZA WIRING DIAGRAM MANUAL

REFERENCE DESIGNATOR INDEX (CONTINUED)

Reference Designator	GAMA/ATA Code	Part Number
CB17	24-52-02	MS24510-15
CB17	24-52-02	MS24510-15
CB17	27-50-01	435-215-104
CB17	27-50-02	MS24510-15
CB17	27-50-02	435-215-104
CB17	27-50-02	MS24510-15
CB18	24-50-01	435-205-104
CB18	24-50-02	7277-2-5
CB18	24-50-02	7277-2-5
CB18	24-51-01	435-205-104
CB18	24-51-02	435-205-104
CB18	24-51-02	435-205-104
CB18	24-52-01	435-205-104
CB18	24-52-02	7277-2-5
CB18	24-52-02	7277-2-5
CB18	32-30-01	435-205-104
CB18	32-30-01	7277-2-5
CB18	32-30-01	7277-2-5
CB18	32-30-02	7277-2-5
CB18	32-30-02	7277-2-5
CB18	32-31-01	7277-2-5
CB18	32-31-01	435-205-104
CB18	32-31-02	7277-2-5
CB18	91-03-01	7277-2-5
CB19	24-50-01	CB2330
CB19	24-50-02	7271-8-30
CB19	24-50-02	7271-8-30
CB19	24-51-01	CB2330
CB19	24-51-02	CB2330
CB19	24-51-02	CB2330
CB19	24-52-01	CB2330
CB19	24-52-02	MS24510-30
CB19	24-52-02	MS24510-30
CB19	32-30-01	CB2330
CB19	32-30-01	MS24510-30
CB19	32-30-01	MS24510-30
CB19	32-30-02	MS24510-30
CB19	32-30-02	MS24510-30
CB19	32-31-01	MS24510-30
CB19	32-31-01	CB2330
CB19	32-31-02	MS24510-30
CB21	24-50-02	7277-2-5
CB21	24-50-02	7277-2-5
CB21	24-51-02	7277-2-5
CB21	24-51-02	7277-2-5
CB21	24-52-02	7277-2-5
CB21	24-52-02	7277-2-5
CB21	73-30-01	7277-2-5
CB22	24-50-01	435-205-104
CB22	24-50-02	7277-2-5
CB22	24-50-02	7277-2-5
CB22	24-51-01	435-205-104
CB22	24-51-02	435-205-104
CB22	24-51-02	435-205-104
CB22	24-52-01	435-205-104
CB22	24-52-02	7277-2-5
CB22	24-52-02	7277-2-5
CB22	34-20-01	435-205-104

Reference Designator	GAMA/ATA Code	Part Number
CB22	34-20-01	7277-2-5
CB23	24-50-01	435-205-104
CB23	24-50-02	7277-2-5
CB23	24-50-02	7277-2-5
CB23	24-51-01	435-205-104
CB23	24-51-02	435-205-104
CB23	24-51-02	435-205-104
CB23	24-52-01	435-205-104
CB23	24-52-02	7277-2-5
CB23	24-52-02	7277-2-5
CB23	33-10-01	435-205-104
CB23	33-10-01	7277-2-5
CB23	33-10-02	435-205-104
CB23	33-10-02	7277-2-5
CB23	33-10-02	7277-2-5
CB23	33-10-02	7277-2-5
CB23	33-10-02	7277-2-5
CB24	24-50-01	435-205-104
CB24	24-50-02	7277-2-5
CB24	24-50-02	7277-2-5
CB24	24-51-01	435-205-104
CB24	24-51-02	435-205-104
CB24	24-51-02	435-205-104
CB24	24-52-01	435-205-104
CB24	24-52-02	7277-2-5
CB24	24-52-02	7277-2-5
CB24	33-11-01	435-205-104
CB24	33-20-01	435-205-104
CB24	33-20-02	7277-2-5
CB25	24-50-01	435-205-104
CB25	24-50-02	7277-2-5
CB25	24-50-02	7277-2-5
CB25	24-51-01	435-205-104
CB25	24-51-02	435-205-104
CB25	24-51-02	435-205-104
CB25	24-52-01	435-205-104
CB25	24-52-02	7277-2-5
CB25	24-52-02	7277-2-5
CB25	33-15-01	435-205-104
CB25	33-15-01	7277-2-5
CB25	33-15-02	435-205-104
CB25	33-15-02	7277-2-5
CB25	36-20-02	435-205-104
CB25	36-20-02	7277-2-5
CB25	36-20-02	435-205-104
CB25	36-20-02	7277-2-5
CB26	24-33-01	435-205-104
CB26	24-33-01	7277-2-5
CB26	24-33-02	7277-2-5
CB26	24-34-01	435-205-104
CB26	24-34-01	7277-2-5
CB26	24-34-02	7277-2-5
CB26	24-50-01	435-205-104
CB26	24-50-02	7277-2-5
CB26	24-50-02	7277-2-5
CB26	24-51-01	435-205-104
CB26	24-51-02	435-205-104
CB26	24-51-02	435-205-104
CB26	24-52-01	435-205-104

Raytheon Aircraft

BEECH BONANZA WIRING DIAGRAM MANUAL

REFERENCE DESIGNATOR INDEX (CONTINUED)

Reference Designator	GAMA/ATA Code	Part Number
CB26	24-52-02	7277-2-5
CB26	24-52-02	7277-2-5
CB26	74-30-01	435-205-104
CB26	74-30-01	7277-2-5
CB26	74-30-02	435-205-104
CB26	74-30-02	7277-2-5
CB27	24-50-01	435-205-104
CB27	24-50-02	7277-2-5
CB27	24-50-02	7277-2-5
CB27	24-51-01	435-205-104
CB27	24-51-02	435-205-104
CB27	24-51-02	435-205-104
CB27	24-52-01	435-205-104
CB27	24-52-02	7277-2-5
CB27	24-52-02	7277-2-5
CB27	33-15-01	435-205-104
CB27	33-15-01	7277-2-5
CB27	33-15-02	435-205-104
CB27	33-15-02	7277-2-5
CB28	24-33-01	7277-2-5
CB28	24-33-01	435-205-104
CB28	24-33-02	7277-2-5
CB28	24-34-01	7277-2-5
CB28	24-34-01	435-205-104
CB28	24-34-02	7277-2-5
CB28	24-50-01	435-205-104
CB28	24-50-02	7277-2-5
CB28	24-50-02	7277-2-5
CB28	24-51-01	435-205-104
CB28	24-51-02	435-205-104
CB28	24-51-02	435-205-104
CB28	24-52-01	435-205-104
CB28	24-52-02	7277-2-5
CB28	24-52-02	7277-2-5
CB28	77-20-01	435-205-104
CB28	77-20-01	7277-2-5
CB29	24-50-01	435-205-104
CB29	24-50-02	7277-2-5
CB29	24-50-02	7277-2-5
CB29	24-51-01	435-205-104
CB29	24-51-02	435-205-104
CB29	24-51-02	435-205-104
CB29	24-52-01	435-205-104
CB29	24-52-02	7277-2-5
CB29	24-52-02	7277-2-5
CB29	32-60-01	435-205-104
CB29	32-60-01	7277-2-5
CB29	32-60-01	7277-2-5
CB29	33-10-01	435-205-104
CB29	33-10-01	7277-2-5
CB29	33-10-02	435-205-104
CB29	33-10-02	7277-2-5
CB29	33-10-02	7277-2-5
CB29	33-10-02	7277-2-5
CB30	24-33-01	7277-2-5
CB30	24-33-01	435-205-104
CB30	24-33-02	7277-2-5
CB30	24-34-01	7277-2-5

Reference Designator	GAMA/ATA Code	Part Number
CB30	24-34-01	435-205-104
CB30	24-34-02	7277-2-5
CB30	24-50-01	435-205-104
CB30	24-50-02	7277-2-5
CB30	24-50-02	7277-2-5
CB30	24-51-01	435-205-104
CB30	24-51-02	435-205-104
CB30	24-51-02	435-205-104
CB30	24-52-01	435-205-104
CB30	24-52-02	7277-2-5
CB30	24-52-02	7277-2-5
CB30	28-40-01	435-205-104
CB30	28-40-02	435-205-104
CB30	28-40-03	435-205-104
CB30	28-40-03	7277-2-5
CB30	28-40-04	7277-2-5
CB30	28-40-05	7277-2-5
CB31	24-50-01	435-210-104
CB31	24-50-02	7277-2-10
CB31	24-50-02	7277-2-5
CB31	24-51-01	435-210-104
CB31	24-51-02	435-210-104
CB31	24-51-02	435-210-104
CB31	24-52-01	435-210-104
CB31	24-52-02	7277-2-10
CB31	24-52-02	7277-2-10
CB31	28-20-01	435-210-104
CB31	28-20-02	435-210-104
CB31	28-20-03	435-210-104
CB31	28-20-03	7277-2-10
CB31	28-20-03	7277-2-10
CB31	28-20-03	435-210-104
CB31	28-20-04	7277-2-10
CB31	28-20-04	435-210-104
CB31	28-20-04	7277-2-10
CB31	28-20-05	435-210-104
CB33	21-50-01	435-210-104
CB33	21-50-01	435-215-104
CB33	21-50-01	MS24510-15
CB33	21-50-02	435-215-104
CB33	21-50-03	7271-8-15
CB33	21-50-03	7271-8-15
CB33	21-50-03	7271-8-15
CB33	21-50-03	7271-8-15
CB33	24-50-01	7277-2-10
CB33	24-50-01	435-210-104
CB33	24-50-01	435-215-104
CB33	24-50-01	435-215-104
CB33	24-50-01	435-210-104
CB33	24-50-02	435-210-104
CB33	24-50-02	7271-8-15
CB33	24-50-02	7271-8-15
CB33	24-51-01	435-210-104
CB33	24-51-02	435-210-104
CB33	24-51-02	435-215-104
CB33	24-51-02	7271-8-15
CB33	24-51-02	7271-8-15
CB33	24-51-02	435-210-104

Raytheon Aircraft

BEECH BONANZA WIRING DIAGRAM MANUAL

REFERENCE DESIGNATOR INDEX (CONTINUED)

Reference Designator	GAMA/ATA Code	Part Number
CB33	24-51-02	7271-8-15
CB33	24-52-01	435-210-104
CB33	24-52-01	7271-8-15
CB33	24-52-02	435-210-104
CB33	24-52-02	7271-8-15
CB33	24-52-02	7271-8-15
CB33	24-52-02	435-210-104
CB34	21-52-01	7270-5-10
CB34	21-52-01	35-380132-33
CB34	21-52-01	35-380132-33
CB34	24-50-02	7270-5-10
CB34	24-50-02	35-380132-33
CB34	24-50-02	35-380132-33
CB34	24-51-02	35-380132-33
CB34	24-51-02	7270-5-10
CB34	24-51-02	35-380132-33
CB34	24-52-02	7270-5-10
CB34	24-52-02	35-380132-33
CB34	24-52-02	35-380132-33
CB34	24-52-02	35-380132-33
CB35	24-50-01	435-205-104
CB35	24-50-02	7277-2-5
CB35	24-50-02	7277-2-5
CB35	24-51-01	435-205-104
CB35	24-51-02	435-205-104
CB35	24-51-02	435-205-104
CB35	24-52-01	435-205-104
CB35	24-52-02	7277-2-5
CB35	24-52-02	7277-2-5
CB35	27-32-01	435-205-104
CB35	27-32-01	7277-2-5
CB44	24-50-01	35-380132-3
CB44	24-50-02	35-380132-3
CB44	24-50-02	35-380132-3
CB44	24-51-01	35-380132-3
CB44	24-51-02	35-380132-3
CB44	24-51-02	35-380132-3
CB44	24-52-01	35-380132-3
CB44	24-52-02	35-380132-3
CB44	24-52-02	35-380132-3
CB44	30-30-01	35-380132-3
CB44	30-30-02	35-380132-3
CB51	24-50-01	35-380132-43
CB51	24-50-02	35-380132-43
CB51	24-50-02	35-380132-43
CB51	24-51-01	35-380132-43
CB51	24-51-02	35-380132-43
CB51	24-51-02	35-380132-43
CB51	24-52-01	35-380132-43
CB51	24-52-02	35-380132-43
CB51	24-52-02	35-380132-43
CB51	24-52-02	35-380132-43
CB51	33-40-01	35-380132-43
CB51	33-40-02	35-380132-43
CB51	33-40-02	35-380132-43
CB53	24-50-01	35-380132-43
CB53	24-50-02	35-380132-43
CB53	24-50-02	35-380132-43
CB53	24-51-01	35-380132-43
CB53	24-51-02	35-380132-43

Reference Designator	GAMA/ATA Code	Part Number
CB53	24-51-02	35-380132-43
CB53	24-52-01	35-380132-43
CB53	24-52-02	35-380132-43
CB53	24-52-02	35-380132-43
CB53	33-44-01	35-380132-43
CB53	33-44-02	35-380132-43
CB53	33-44-02	35-380132-43
CB53	33-44-02	35-380132-43
CB54	24-50-01	35-380132-41
CB54	24-50-02	35-380132-41
CB54	24-50-02	35-380132-41
CB54	24-51-01	35-380132-41
CB54	24-51-02	35-380132-41
CB54	24-51-02	35-380132-41
CB54	24-52-01	35-380132-41
CB54	24-52-02	35-380132-41
CB54	24-52-02	35-380132-41
CB54	33-11-01	35-380132-41
CB54	33-11-02	35-380132-41
CB54	33-11-02	35-380132-41
CB54	33-45-01	35-380132-41
CB54	33-45-01	35-380132-41
CB55	24-50-01	35-380132-43
CB55	24-50-02	35-380132-43
CB55	24-50-02	35-380132-43
CB55	24-51-01	35-380132-43
CB55	24-51-02	35-380132-43
CB55	24-51-02	35-380132-43
CB55	24-52-01	35-380132-43
CB55	24-52-02	35-380132-43
CB55	24-52-02	35-380132-43
CB55	33-43-01	35-380132-43
CB56	24-50-01	35-380132-43
CB56	24-50-02	35-380132-43
CB56	24-50-02	35-380132-43
CB56	24-51-01	35-380132-43
CB56	24-51-02	35-380132-43
CB56	24-51-02	35-380132-43
CB56	24-52-01	35-380132-43
CB56	24-52-02	35-380132-43
CB56	24-52-02	35-380132-43
CB56	33-46-01	35-380132-43
CB57	24-50-01	35-380132-9
CB57	24-50-02	35-380132-9
CB57	24-50-02	35-380132-9
CB57	24-51-01	35-380132-9
CB57	24-51-02	35-380132-9
CB57	24-51-02	35-380132-9
CB57	24-52-01	35-380132-9
CB57	24-52-02	35-380132-9
CB57	24-52-02	35-380132-9
CB57	30-60-01	35-380132-9
CB57	30-60-01	35-380132-9
CB58	24-50-02	35-380132-39
CB58	24-51-02	35-380132-39
CB58	24-51-02	35-380132-39
CB58	24-52-02	35-380132-39
CB58	24-52-02	35-380132-39

Raytheon Aircraft

BEECH BONANZA WIRING DIAGRAM MANUAL

REFERENCE DESIGNATOR INDEX (CONTINUED)

Reference Designator	GAMA/ATA Code	Part Number
CR31	24-34-02	132408-22
CR32	24-33-01	1.5KE51CA
CR32	24-33-02	1.5KE51CA
CR32	24-34-01	1.5KE51CA
CR32	24-34-02	1.5KE51CA
CR33	24-33-01	1N1202A
CR33	24-33-01	132408-10
CR33	24-33-02	1N1202A
CR33	24-33-02	132408-10
CR33	24-34-01	1N1202A
CR33	24-34-01	132408-10
CR33	24-34-02	1N1202A
CR33	24-34-02	132408-10
CR34	24-33-01	1N4007
CR34	24-33-01	132408-22
CR34	24-33-02	1N4007
CR34	24-33-02	132408-22
CR34	24-34-01	1N4007
CR34	24-34-01	132408-22
CR34	24-34-02	1N4007
CR34	24-34-02	132408-22
CR35	32-31-01	1N4007
CR35	32-31-01	132408-22
CR35	32-31-02	1N4007
CR35	32-31-02	132408-22
CR36	32-31-01	1N5400
CR36	32-31-02	1N5400
CR37	21-50-01	1N1199A
CR37	21-50-01	132408-9
CR37	21-50-02	1N1199A
CR37	21-50-02	132408-9
CR37	21-50-03	1N1199A
CR37	21-50-03	132408-9
CR37	21-50-03	1N1199A
CR37	21-50-03	132408-9
CR37	21-50-03	1N1199A
CR37	21-50-03	132408-9
CR37	21-50-03	1N1199A
CR37	21-50-03	132408-9
CR37	21-50-03	1N1199A
CR37	21-50-03	132408-9
CR38	27-50-02	1.5KE51CA
CR38	27-50-02	1.5KE51CA
CR39	27-50-02	1.5KE51CA
CR39	27-50-02	1.5KE51CA
CR4	39-10-40	1N3611
CR4	39-10-40	132408-18
CR4	39-10-41	1N3611
CR4	39-10-41	132408-18
CR40	24-33-01	1N4007
CR40	24-33-01	132408-22
CR40	24-33-02	1N4007
CR40	24-33-02	132408-22
CR40	24-34-01	1N4007
CR40	24-34-01	132408-22
CR40	24-34-02	1N4007
CR40	24-34-02	132408-22
CR41	24-33-01	1.5KE51CA
CR41	24-33-02	1.5KE51CA
CR41	24-34-01	1.5KE51CA

Reference Designator	GAMA/ATA Code	Part Number
CR41	24-34-02	1.5KE51CA
CR42	24-33-01	1N4007
CR42	24-33-01	132408-22
CR42	24-33-02	1N4007
CR42	24-33-02	132408-22
CR42	24-34-01	1N4007
CR42	24-34-01	132408-22
CR42	24-34-02	1N4007
CR42	24-34-02	132408-22
CR43	24-33-01	1N4007
CR43	24-33-01	132408-22
CR43	24-33-02	1N4007
CR43	24-33-02	132408-22
CR43	24-34-01	1N4007
CR43	24-34-01	132408-22
CR43	24-34-02	1N4007
CR43	24-34-02	132408-22
CR43	24-34-02	1N4007
CR43	24-34-02	132408-22
CR44	24-34-02	1N4007
CR44	24-34-02	132408-22
CR45	33-10-02	1N4007
CR45	33-10-02	132408-22
CR5	39-10-40	1N3611
CR5	39-10-40	132408-18
CR5	39-10-41	1N3611
CR5	39-10-41	132408-18
CR53	33-45-01	1.5KE51AC
CR6	39-10-40	1N4734A
CR6	39-10-40	132409-31
CR6	39-10-41	1N4734A
CR6	39-10-41	132409-31
C1	39-10-40	CKR06BX104KR
C1	39-10-40	132389D104EHM
C1	39-10-41	CKR06BX104KR
C1	39-10-41	132389D104EHM
C10	24-33-01	39D507G050GL4
C10	24-33-02	39D507G050GL4
C10	24-34-01	39D507G050GL4
C10	24-34-02	39D507G050GL4
C11	24-30-01	121P60501R5V1
C11	24-30-01	35-360011-5
C11	24-30-01	121P60501R5V1
C11	24-30-01	35-360011-5
C11	24-30-02	39D507G050GL4
C11	24-30-02	39D507G050GL4
C11	24-30-03	39D507G050GL4
C11	24-30-03	39D507G050GL4
C11	24-30-04	39D507G050GL4
C11	24-30-04	39D507G050GL4
C11	24-30-04	39D507G050GL4
C11	24-30-04	39D507G050GL4
C2	39-10-40	150D476X9035S2
C2	39-10-40	132391D47R00FMU
C2	39-10-41	150D476X9035S2
C2	39-10-41	132391D47R00FMU
C3	39-10-40	CKR06BX104KR
C3	39-10-40	132389D104EHM
C3	39-10-41	CKR06BX104KR
C3	39-10-41	132389D104EHM

Raytheon Aircraft

BEECH BONANZA WIRING DIAGRAM MANUAL

REFERENCE DESIGNATOR INDEX (CONTINUED)

Reference Designator	GAMA/ATA Code	Part Number
C4	39-10-40	CKR06BX104KR
C4	39-10-40	132389D104EHM
C4	39-10-41	CKR06BX104KR
C4	39-10-41	132389D104EHM
C5	39-10-40	CKR06BX104KR
C5	39-10-40	132389D104EHM
C5	39-10-41	CKR06BX104KR
C5	39-10-41	132389D104EHM
C6	39-10-40	CK05BX471K
C7	39-10-40	162D476X9004DD2
C7	39-10-41	162D476X9004DD2
C8	39-10-40	173D336X9006W
C8	39-10-41	173D336X9006W
DS101	33-14-01	327
DS101	33-14-02	327
DS101	33-14-03	327
DS101	33-17-01	327
DS101	33-17-02	327
DS101	33-17-03	327
DS102	33-17-01	327
DS104	33-20-01	1864
DS104	33-20-02	1864
DS105	33-20-01	1864
DS105	33-20-02	1864
DS106	33-20-01	303
DS106	33-20-02	303
DS107	33-20-01	303
DS107	33-20-02	303
DS108	33-20-01	303
DS108	33-20-02	303
DS109	33-20-01	303
DS109	33-20-02	303
DS11A	33-40-01	30-0815-5
DS11A	33-40-01	30-0815-1
DS11A	33-40-02	30-0815-5
DS11A	33-40-02	A500A-B28
DS11A	33-40-02	30-0516-13
DS11A	33-40-02	A500A-B28
DS11A	33-40-02	30-0516-13
DS11B	33-40-01	31-2440-3
DS11B	33-40-02	31-2440-5
DS11B	33-40-02	A506
DS11B	33-40-02	31-1780-1
DS11B	33-40-02	A506
DS11B	33-40-02	31-1780-1
DS11C	33-40-01	678
DS11C	33-40-02	678
DS11C	33-40-02	A510
DS11C	33-40-02	31-1740-9
DS11C	33-40-02	A510
DS11C	33-40-02	31-1740-9
DS11D	33-40-02	A508
DS11D	33-40-02	31-1745
DS11D	33-40-02	A508
DS11D	33-40-02	31-1745
DS11E	33-40-02	A457A
DS11E	33-40-02	678
DS11E	33-40-02	A457A

Reference Designator	GAMA/ATA Code	Part Number
DS11E	33-40-02	678
DS11F	33-40-02	A457A-0
DS11F	33-40-02	A457A-0
DS112	33-13-01	327
DS112	33-13-02	327
DS112	33-13-03	327
DS113	33-13-01	327
DS113	33-13-02	327
DS113	33-13-03	327
DS114	33-13-01	327
DS114	33-13-02	327
DS114	33-13-03	327
DS115	33-13-01	327
DS115	33-13-02	327
DS115	33-13-03	327
DS116	33-13-01	327
DS116	33-13-02	327
DS116	33-13-03	327
DS117	33-13-01	327
DS117	33-13-02	327
DS117	33-13-03	327
DS118	33-13-01	327
DS118	33-13-02	327
DS118	33-13-03	327
DS119	33-17-01	327
DS119	33-17-02	327
DS119	33-17-03	327
DS12A	33-40-02	30-1331-3
DS12A	33-40-02	701148-7-2
DS12A	33-40-02	30-1331-3
DS12A	33-40-02	701148-7-2
DS12A1	33-40-01	30-1331-3
DS12A2	33-40-01	701148-7-2
DS12B	33-40-02	25-0491-1
DS12B	33-40-02	202065
DS12B	33-40-02	25-0491-1
DS12B	33-40-02	202065
DS12B1	33-40-01	25-0491-1
DS12B2	33-40-01	202065
DS12C	33-40-02	31-3792-7
DS12C	33-40-02	203382
DS12C	33-40-02	31-3792-7
DS12C	33-40-02	203382
DS12C1	33-40-01	31-3792-7
DS12C2	33-40-01	2023382
DS12D	33-40-02	55-0221-1
DS12D	33-40-02	202331
DS12D	33-40-02	55-0221-1
DS12D	33-40-02	202331
DS12D1	33-40-01	55-0221
DS12D2	33-40-01	202331
DS12E	33-40-02	30-1467-101
DS12E	33-40-02	202323
DS12E	33-40-02	30-1467-101
DS12E	33-40-02	202323
DS12E2	33-40-01	202323
DS12F	33-40-02	202055
DS12F	33-40-02	202055

Raytheon Aircraft

BEECH BONANZA WIRING DIAGRAM MANUAL

REFERENCE DESIGNATOR INDEX (CONTINUED)

Reference Designator	GAMA/ATA Code	Part Number
DS12F2	33-40-01	202055
DS12G	33-40-02	MS3102A10SL3P
DS12G	33-40-02	MS3102A10SL3P
DS12G2	33-40-01	MS3102A10SL3P
DS120A	33-14-01	58-380022-11
DS120A	33-14-02	58-380022-11
DS120A	33-14-03	58-380022-11
DS120B	33-14-01	267
DS120B	33-14-02	267
DS120B	33-14-03	267
DS121	33-10-02	327
DS13	33-40-01	30-1331-3
DS13	33-40-01	701148-7-2
DS13	33-40-02	30-1331-3
DS13	33-40-02	701148-7-2
DS13	33-40-02	30-1331-3
DS13	33-40-02	701148-7-2
DS14	33-16-01	35-380126-15
DS140A	33-44-01	36-364030-13
DS140A	33-44-01	36-364030-15
DS140A	33-44-02	36-364030-15
DS140A	33-44-02	36-364030-15
DS140A	33-44-02	36-364030-13
DS140B	33-44-01	D7080A3-24
DS140B	33-44-01	D7080A1-24
DS140B	33-44-02	D7080A3-24
DS140B	33-44-02	D7080A1-24
DS140B	33-44-02	D7080A3-24
DS140C	33-44-01	A7079B24
DS140C	33-44-01	A7079B24
DS140C	33-44-02	A7079B24
DS140C	33-44-02	A7079B24
DS140C	33-44-02	A7079B24
DS140D	33-44-01	41-0190-1
DS140D	33-44-01	A7942
DS140D	33-44-02	A7942
DS140D	33-44-02	A7942
DS140D	33-44-02	A7942
DS140E	33-44-01	A7632
DS140E	33-44-02	A7632
DS140E	33-44-02	A7632
DS140E	33-44-02	A7632
DS140F	33-44-01	41-0190-1
DS140F	33-44-02	41-0190-1
DS140F	33-44-02	41-0190-1
DS140F	33-44-02	41-0190-1
DS140G	33-44-02	36-364036-3
DS140G	33-44-02	36-364036-3
DS140H	33-44-02	WRML24CW
DS140H	33-44-02	WRML24CW
DS140J	33-44-02	WRM40
DS140J	33-44-02	WRM40
DS140K	33-44-02	WRM30
DS140K	33-44-02	WRM30
DS140L	33-44-02	WRML20L
DS140L	33-44-02	WRML20
DS140M	33-44-02	WRM1939
DS140M	33-44-02	WRM1939

Reference Designator	GAMA/ATA Code	Part Number
DS140N	33-44-02	WRM15
DS140N	33-44-02	WRM15
DS140P	33-44-02	WRM10
DS140P	33-44-02	WRM10
DS140Q	33-44-02	36-364030-15
DS140Q	33-44-02	36-364030-15
DS140R	33-44-02	D7080A3-24
DS140R	33-44-02	D7080A1-24
DS140S	33-44-02	A7079B24
DS140S	33-44-02	A7079B24
DS140T	33-44-02	41-0190-1
DS140T	33-44-02	41-0190-1
DS141A	33-44-01	36-364030-11
DS141A	33-44-01	36-364030-11
DS141A	33-44-02	36-364030-41
DS141A	33-44-02	36-364030-41
DS141A	33-44-02	36-364030-41
DS141A	33-44-02	36-364030-41
DS141B	33-44-01	D7080A5-24
DS141B	33-44-02	D7080A5-24
DS141B	33-44-02	D7080A5-24
DS141B	33-44-02	D7080A5-24
DS141B	33-44-02	D7080A5-24
DS141B	33-44-02	D7080A5-24
DS141C	33-44-01	A7079B24
DS141C	33-44-02	A7079B24
DS141C	33-44-02	A7079B24
DS141C	33-44-02	A7079B24
DS141C	33-44-02	A7079B24
DS141C	33-44-02	A7079B24
DS141D	33-44-01	A7942
DS141D	33-44-02	A7942
DS141D	33-44-02	A7942
DS141D	33-44-02	A7942
DS141D	33-44-02	A7942
DS141D	33-44-02	A7942
DS141E	33-44-01	A7632
DS141E	33-44-02	A7632
DS141E	33-44-02	A7632
DS141E	33-44-02	A7632
DS141E	33-44-02	A7632
DS141F	33-44-01	41-0190-3
DS141F	33-44-02	41-0190-3
DS141F	33-44-02	41-0190-3
DS141F	33-44-02	41-0190-1
DS141F	33-44-02	41-0190-1
DS141G	33-44-02	36-364036-7
DS141G	33-44-02	36-364036-7
DS141G	33-44-02	36-364036-7
DS141G	33-44-02	36-364030-41
DS141G	33-44-02	36-364030-11
DS141H	33-44-02	WRML24CCW
DS141H	33-44-02	WRML24CCW
DS141H	33-44-02	WRML24CCW
DS141H	33-44-02	D7080A5-24
DS141H	33-44-02	D7080A5-24
DS141J	33-44-02	WRM40
DS141J	33-44-02	WRM40
DS141J	33-44-02	WRM40
DS141J	33-44-02	A7079B24
DS141J	33-44-02	A7079B24

Raytheon Aircraft

BEECH BONANZA WIRING DIAGRAM MANUAL

REFERENCE DESIGNATOR INDEX (CONTINUED)

Reference Designator	GAMA/ATA Code	Part Number
DS141K	33-44-02	WRM30
DS141K	33-44-02	WRM30
DS141K	33-44-02	WRM30
DS141K	33-44-02	A7942
DS141K	33-44-02	A7942
DS141L	33-44-02	WRM20L
DS141L	33-44-02	WRM20L
DS141L	33-44-02	WRM20L
DS141L	33-44-02	A7632
DS141L	33-44-02	A7632
DS141M	33-44-02	WRM1939
DS141M	33-44-02	WRM1939
DS141M	33-44-02	WRM1939
DS141M	33-44-02	41-0109-3
DS141M	33-44-02	41-0109-3
DS141N	33-44-02	WRM15
DS141N	33-44-02	WRM15
DS141N	33-44-02	WRM15
DS141N	33-44-02	36-364036-7
DS141N	33-44-02	36-364036-7
DS141P	33-44-02	WRM10
DS141P	33-44-02	WRM10
DS141P	33-44-02	WRM10
DS141P	33-44-02	WRML24CCW
DS141P	33-44-02	WRML24CCW
DS141Q	33-44-02	36-364030-41
DS141Q	33-44-02	WRM40
DS141Q	33-44-02	WRM40
DS141R	33-44-02	D7080A5-24
DS141R	33-44-02	WRM30
DS141R	33-44-02	WRM30
DS141S	33-44-02	A7079B24
DS141S	33-44-02	WRM20L
DS141S	33-44-02	WRM20L
DS141T	33-44-02	41-0190-3
DS141T	33-44-02	WRM1939
DS141T	33-44-02	WRM1939
DS141U	33-44-02	102-364031-3
DS141U	33-44-02	102-364031-3
DS141U	33-44-02	WRM15
DS141U	33-44-02	WRM15
DS141V	33-44-02	40-0100-3C
DS141V	33-44-02	40-0100-3C
DS141V	33-44-02	WRM10
DS141V	33-44-02	WRM10
DS141W	33-44-02	D9961
DS141W	33-44-02	D9961
DS141W	33-44-02	102-364031-3
DS141X	33-44-02	36112
DS141X	33-44-02	36112
DS141X	33-44-02	40-0100-3C
DS141Y	33-44-02	A7079B24
DS141Y	33-44-02	A7079B24
DS141Y	33-44-02	D9961-3
DS141Z	33-44-02	55-0069-1
DS141Z	33-44-02	55-0069-1
DS141Z	33-44-02	36112
DS141ZA	33-44-02	41-0832-9

Reference Designator	GAMA/ATA Code	Part Number
DS141ZA	33-44-02	41-0832-9
DS141ZA	33-44-02	A7079B24
DS141ZB	33-44-02	55-0069-1
DS141ZC	33-44-02	41-0832-9
DS144	32-60-01	327
DS144	32-60-01	327
DS145	32-60-01	327
DS145	32-60-01	327
DS146	32-60-01	327
DS146	32-60-01	327
DS147	32-60-01	327
DS147	32-60-01	327
DS148	32-60-02	327
DS15	33-16-01	35-380133-55
DS15	33-16-01	35-380133-19
DS15	33-16-01	35-380133-53
DS15	33-16-01	35-380133-57
DS15	33-16-01	35-380133-59
DS15	33-16-01	35-380133-65
DS15	33-16-01	35-380133-63
DS15	33-16-01	35-380133-67
DS15	33-16-01	35-380133-69
DS15	33-16-01	35-380133-61
DS15	33-16-01	35-380133-71
DS15	33-16-01	35-380133-73
DS15	33-16-01	35-380133-75
DS15	33-16-01	35-380133-79
DS15	33-16-01	35-380133-81
DS15	33-16-01	35-380133-77
DS15	33-16-01	35-380133-83
DS15	33-16-01	35-380133-85
DS15	33-16-01	35-380133-87
DS151	33-10-02	327
DS151	33-10-02	327
DS152	33-10-02	327
DS152	33-10-02	327
DS16	33-16-01	36-380019-9
DS16	33-16-01	36-380019-15
DS16	33-16-01	36-380019-23
DS16	33-16-01	36-380019-25
DS16	33-16-01	36-380019-33
DS16	33-16-01	36-380019-37
DS16	33-16-01	36-380019-35
DS16	33-16-01	36-380074-1
DS16	33-16-01	36-380074-3
DS16	33-16-01	36-380074-5
DS17	33-11-01	1495
DS17	33-11-02	1495
DS17	33-11-02	1495
DS18	33-11-01	MS25237-327
DS18	33-11-02	MS25237-327
DS18	33-11-02	MS25237-327
DS19	33-11-01	327
DS19	33-11-02	327
DS19	33-11-02	327
DS20	33-46-01	4596
DS21	33-43-01	4596
DS22	33-45-01	A2064-1683

Raytheon Aircraft

BEECH BONANZA WIRING DIAGRAM MANUAL

REFERENCE DESIGNATOR INDEX (CONTINUED)

Reference Designator	GAMA/ATA Code	Part Number
DS22	33-45-01	A2064-1683
DS23	33-45-01	A7512-24
DS23	33-45-01	A7512-24
DS25	33-45-01	A7512-24
DS25	33-45-01	A7512-24
DS26	33-10-02	327
DS26	33-10-02	327
DS26	33-10-02	327
DS28A	33-18-01	313
DS28A	33-18-01	313
DS28B	33-18-01	D165-100-2
DS28B	33-18-01	D165-100-2
DS29A	33-18-01	313
DS29A	33-18-01	313
DS29B	33-18-01	D165-100-2
DS29B	33-18-01	D165-100-2
DS30	24-33-01	313
DS30	24-33-02	313
DS30	24-34-01	313
DS30	24-34-02	313
DS30A	33-18-01	313
DS30A	33-18-01	313
DS30B	33-18-01	D165-100-2
DS30B	33-18-01	D165-100-2
DS31A	33-18-01	313
DS31A	33-18-01	313
DS31B	33-18-01	D165-100-2
DS31B	33-18-01	D165-100-2
DS32A	33-18-01	313
DS32A	33-18-01	313
DS32B	33-18-01	D165-100-2
DS32B	33-18-01	D165-100-2
DS33A	33-18-01	313
DS33A	33-18-01	313
DS33B	33-18-01	D165-100-2
DS33B	33-18-01	D165-100-2
DS34A	33-18-01	313
DS34A	33-18-01	313
DS34B	33-18-01	D165-100-2
DS34B	33-18-01	D165-100-2
DS35A	33-18-01	313
DS35A	33-18-01	313
DS35B	33-18-01	D165-100-2
DS35B	33-18-01	D165-100-2
DS36A	33-18-01	313
DS36A	33-18-01	313
DS36B	33-18-01	D165-100-2
DS36B	33-18-01	D165-100-2
DS37A	33-18-01	313
DS37A	33-18-01	313
DS37B	33-18-01	D165-100-2
DS37B	33-18-01	D165-100-2
DS38A	33-18-01	313
DS38A	33-18-01	313
DS38B	33-18-01	D165-100-2
DS38B	33-18-01	D165-100-2
DS39A	33-18-01	313
DS39A	33-18-01	313

Reference Designator	GAMA/ATA Code	Part Number
DS39B	33-18-01	D165-100-2
DS39B	33-18-01	D165-100-2
DS42A	33-42-01	30-0502-5
DS42B	33-42-01	31-1705-3
DS42C	33-42-01	1864
DS43A	33-42-01	30-0502-5
DS43B	33-42-01	31-1705-3
DS43C	33-42-01	1864
DS45	33-10-01	327
DS45	33-10-02	327
DS45	33-10-02	327
DS45	33-10-02	327
DS5	36-20-02	MS25237-327
DS5	36-20-02	MS25237-327
DS53A	33-14-01	1819
DS53A	33-14-02	1819
DS53A	33-14-03	1819
DS53A	33-17-01	1819
DS53A	33-17-02	1819
DS53A	33-17-03	1819
DS53A	33-18-01	1819
DS53A	33-18-01	1819
DS53B	33-14-01	D165-100-2
DS53B	33-14-02	D165-100-2
DS53B	33-14-03	D165-100-2
DS53B	33-17-01	D165-100-2
DS53B	33-17-02	D165-100-2
DS53B	33-17-03	D165-100-2
DS53B	33-18-01	D165-100-2
DS53B	33-18-01	D165-100-2
DS55A	33-14-01	58-380022-11
DS55B	33-14-01	267
DS56A	33-14-01	58-380022-11
DS56A	33-14-02	58-380022-11
DS56A	33-14-03	58-380022-11
DS56B	33-14-01	267
DS56B	33-14-02	267
DS56B	33-14-03	267
DS57A	33-14-01	58-380022-11
DS57A	33-14-02	58-380022-11
DS57A	33-14-03	58-380022-11
DS57B	33-14-01	267
DS57B	33-14-02	267
DS57B	33-14-03	267
DS58A	33-14-01	58-380022-11
DS58A	33-14-02	58-380022-11
DS58A	33-14-03	58-380022-11
DS58B	33-14-01	267
DS58B	33-14-02	267
DS58B	33-14-03	267
DS59A	33-14-01	58-380022-11
DS59A	33-14-02	58-380022-11
DS59A	33-14-03	58-380022-11
DS59B	33-14-01	267
DS59B	33-14-02	267
DS59B	33-14-03	267
DS6	36-20-02	MS25237-327
DS6	36-20-02	MS25237-327

Raytheon Aircraft

BEECH BONANZA WIRING DIAGRAM MANUAL

REFERENCE DESIGNATOR INDEX (CONTINUED)

Reference Designator	GAMA/ATA Code	Part Number
DS60A	33-14-01	58-380022-11
DS60A	33-14-02	58-380022-11
DS60A	33-14-03	58-380022-11
DS60B	33-14-01	267
DS60B	33-14-02	267
DS60B	33-14-03	267
DS61A	33-14-01	58-380022-11
DS61A	33-14-02	58-380022-11
DS61A	33-14-03	58-380022-11
DS61B	33-14-01	267
DS61B	33-14-02	267
DS61B	33-14-03	267
DS62A	33-14-01	58-380022-11
DS62A	33-14-02	58-380022-11
DS62A	33-14-03	58-380022-11
DS62B	33-14-01	267
DS62B	33-14-02	267
DS62B	33-14-03	267
DS65	33-17-01	327
DS65	33-17-02	327
DS65	33-17-03	327
DS66	33-17-01	327
DS66	33-17-02	327
DS66	33-17-03	327
DS67	33-17-01	327
DS67	33-17-02	327
DS67	33-17-03	327
DS68	33-17-01	327
DS68	33-17-02	327
DS68	33-17-03	327
DS69	33-17-01	327
DS69	33-17-02	327
DS69	33-17-03	327
DS70	33-17-01	327
DS70	33-17-02	327
DS70	33-17-03	327
DS71	33-17-01	327
DS71	33-17-02	327
DS71	33-17-03	327
DS72	33-17-01	327
DS72	33-17-02	327
DS72	33-17-03	327
DS73	33-17-01	327
DS73	33-17-02	327
DS73	33-17-03	327
DS74	33-17-01	327
DS74	33-17-02	327
DS74	33-17-03	327
DS77	33-17-01	327
DS77	33-17-02	327
DS77	33-17-03	327
DS78	33-17-01	327
DS78	33-17-02	327
DS78	33-17-03	327
DS79	33-17-01	327
DS79	33-17-02	327
DS79	33-17-03	327
DS80	33-17-01	327

Reference Designator	GAMA/ATA Code	Part Number
DS80	33-17-02	327
DS80	33-17-03	327
DS81A	33-12-01	58-380022-11
DS81A	33-12-02	58-380022-11
DS81A	33-12-03	58-380022-11
DS81B	33-12-01	267
DS81B	33-12-02	267
DS81B	33-12-03	267
DS82A	33-12-01	58-380022-11
DS82A	33-12-02	58-380022-11
DS82A	33-12-03	58-380022-11
DS82B	33-12-01	267
DS82B	33-12-02	267
DS82B	33-12-03	267
DS83A	33-12-01	58-380022-11
DS83A	33-12-02	58-380022-11
DS83A	33-12-03	58-380022-11
DS83B	33-12-01	267
DS83B	33-12-02	267
DS83B	33-12-03	267
DS84A	33-12-01	58-380022-11
DS84A	33-12-02	58-380022-11
DS84A	33-12-03	58-380022-11
DS84B	33-12-01	267
DS84B	33-12-02	267
DS84B	33-12-03	267
DS85A	33-12-01	58-380022-11
DS85A	33-12-02	58-380022-11
DS85A	33-12-03	58-380022-11
DS85B	33-12-01	267
DS85B	33-12-02	267
DS85B	33-12-03	267
DS90	33-11-01	267
DS90	33-11-02	267
DS90	33-17-01	267
DS91A	24-33-01	58-380022-11
DS91A	24-33-02	58-380022-11
DS91A	24-34-01	58-380022-11
DS91A	24-34-02	58-380022-11
DS91B	24-33-01	267
DS91B	24-33-02	267
DS91B	24-34-01	267
DS91B	24-34-02	267
DS95	33-11-01	327
DS95	33-11-02	327
DS95	33-11-02	327
DS96	33-11-01	327
DS96	33-11-02	327
DS96	33-11-02	327
DS97	33-10-01	327
DS97	33-10-02	327
DS97	33-10-02	327
DS97	33-10-02	327
E10	30-60-01	3E1964-3
E10	30-60-01	3E1964-3
E11	30-60-01	3E2062
E11	30-60-01	3E2062

Raytheon Aircraft

BEECH BONANZA WIRING DIAGRAM MANUAL

REFERENCE DESIGNATOR INDEX (CONTINUED)

Reference Designator	GAMA/ATA Code	Part Number
F26	24-30-03	AGC5
F26	24-30-04	AGC5
F26	24-30-04	AGC5
F26	24-30-04	AGC5
F26	24-30-04	AGC5
F28	25-11-01	AGC5
F28	25-11-02	AGC5
F28	25-12-01	AGC5
F28	25-12-02	AGC5
F28	25-12-03	AGC5
F3	24-30-01	FLLA
F3	24-30-01	FLLA
F3	24-30-02	FLLA
F3	24-30-02	FLLA
F3	24-30-03	FLLA
F3	24-30-03	FLLA
F3	24-30-04	FLLA
F3	24-30-04	FLLA
F3	24-30-04	FLLA
F3	24-30-04	FLLA
F30	36-20-02	AGC5
F30	36-20-02	AGC5
F31	24-30-03	AGC5
F31	24-30-03	AGC5
F31	24-30-04	AGC5
F32	24-30-04	BW20F(1056)
F33	34-22-01	AGC5
GS1	21-50-03	131270-3
GS1	21-50-03	131270-3
GS1	21-50-03	131270-3
GS1	27-50-02	131270-3
GS1	27-50-02	131270-3
GS1	32-30-01	131270-3
GS1	32-30-02	131270-3
GS1	32-31-01	131270-3
GS1	32-31-02	131270-3
GS1	32-60-01	131270-3
GS1	33-15-01	131270-3
GS1	33-44-02	131270-3
GS1	33-44-02	131270-3
GS1	33-44-02	131270-3
GS1	33-44-02	131270-3
GS2	24-30-01	131270-3
GS2	24-30-01	131270-3
GS2	24-33-01	131270-3
GS2	24-33-02	131270-3
GS2	24-34-01	131270-3
GS2	24-34-02	131270-3
GS2	30-60-01	131270-3
GS2	30-60-01	131270-3
GS2A	33-43-01	131270-3
GS2B	33-43-01	AN960-10
GS2C	33-43-01	MS21045L3
GS3	24-30-01	131270-3
GS3	24-30-02	131270-3
GS3	24-30-02	131270-3
GS3	24-30-03	131270-3
GS3	24-30-03	131270-3
GS3	24-30-04	131270-3

Reference Designator	GAMA/ATA Code	Part Number
GS3	24-30-04	131270-3
GS3	24-30-04	131270-3
GS3	24-30-04	131270-3
GS3	32-31-02	131270-3
GS3	32-60-01	131270-3
GS3	32-60-01	131270-3
GS3	77-20-01	131270-3
GS4	24-30-02	AN3-5A
GS4	24-30-02	AN3-5A
GS4	24-30-03	AN3-5A
GS4	24-30-03	AN3-5A
GS4	24-30-04	AN3-5A
GS4	24-30-04	AN3-5A
GS4	24-30-04	AN3-5A
GS4	24-30-04	AN3-5A
GS4A	33-43-01	AN3-5A
GS4B	33-43-01	AN960-10L
GS4C	33-43-01	MS21042L3
GS5	28-20-03	131270-3
GS5	28-20-03	131270-3
GS5	28-20-04	131270-3
GS5	28-20-05	131270-3
GS5	32-60-01	131270-3
GS5	32-60-01	131270-3
GS5	33-11-02	131270-3
GS5	33-11-02	131270-3
GS5	33-15-01	131270-3
GS5	33-15-02	131270-3
G17	24-33-01	36-380048-1
G17	24-33-02	36-380048-1
G17	24-34-01	36-380048-1
G17	24-34-02	36-380048-1
G18	24-30-01	640789
G18	24-30-01	641668
G18	24-30-01	ALT9422
G18	24-30-01	ALV9407
G18	24-30-01	640789
G18	24-30-01	641668
G18	24-30-01	ALT9422
G18	24-30-01	ALV9407
G18	24-30-02	641668
G18	24-30-02	ALT9422
G18	24-30-02	640789
G18	24-30-02	ALV9407
G18	24-30-02	641668
G18	24-30-02	ALT9422
G18	24-30-02	ALV9407
G18	24-30-02	640789
G18	24-30-03	642056A2
G18	24-30-03	641668
G18	24-30-03	ALT9422
G18	24-30-03	642056
G18	24-30-03	642056A2
G18	24-30-03	642056A2
G18	24-30-03	641668
G18	24-30-03	ALT9422
G18	24-30-03	642056
G18	24-30-03	642056A2

Raytheon Aircraft

BEECH BONANZA WIRING DIAGRAM MANUAL

REFERENCE DESIGNATOR INDEX (CONTINUED)

Reference Designator	GAMA/ATA Code	Part Number
J11B	33-45-01	206070-1
J11B	91-13-01	206070-1
J11C	21-50-01	66099-2
J11C	21-50-02	66099-2
J11C	21-50-03	66099-2
J11C	21-50-03	66099-2
J11C	21-50-03	66099-2
J11C	21-50-03	66099-2
J11C	28-40-01	66099-2
J11C	28-40-02	66099-2
J11C	28-40-03	66099-2
J11C	28-40-04	66099-2
J11C	28-40-05	66099-2
J11C	32-60-01	66099-2
J11C	32-60-01	66099-2
J11C	33-45-01	66099-2
J11C	33-45-01	66099-2
J11C	91-13-01	66103-2
J11D	21-50-01	66103-2
J11D	21-50-02	66103-2
J11D	21-50-03	66103-2
J11D	21-50-03	66103-2
J11D	21-50-03	66103-2
J11D	21-50-03	66103-2
J11D	28-40-01	66103-2
J11D	28-40-02	66103-2
J11D	28-40-03	66103-2
J11D	28-40-04	66103-2
J11D	28-40-05	66103-2
J11D	32-60-01	66103-2
J11D	32-60-01	66103-2
J11D	33-45-01	66103-2
J11D	33-45-01	66103-2
J11D	91-13-01	66099-2
J115A	21-50-02	206705-2
J115A	32-30-02	206705-2
J115A	32-30-02	206705-2
J115A	32-31-02	206705-2
J115B	21-50-02	206966-1
J115B	32-30-02	206966-1
J115B	32-30-02	206966-1
J115B	32-31-02	206966-1
J115C	21-50-02	66103-2
J115C	32-30-02	66103-2
J115C	32-30-02	66103-2
J115C	32-31-02	66103-2
J116	21-50-03	207443-1
J116	21-50-03	207443-1
J116	21-50-03	207443-1
J116	21-50-03	207443-1
J116	32-30-02	207443-1
J116	32-30-02	207443-1
J116	91-03-01	207443-1
J121A	33-12-02	1-480288-0
J121B	33-12-02	350444-5
J121C	33-12-02	60618-1
J122A	33-12-02	1-480288-0
J122A	33-13-02	1-480288-0

Reference Designator	GAMA/ATA Code	Part Number
J122B	33-12-02	350444-5
J122B	33-13-02	350444-5
J122C	33-12-02	60618-1
J122C	33-13-02	60618-1
J123A	33-14-02	1-480288-0
J123A	33-17-02	1-480288-0
J123B	33-14-02	350444-5
J123B	33-17-02	350444-5
J123C	33-14-02	60618-1
J123C	33-17-02	60618-1
J124A	33-14-02	1-480288-0
J124A	33-17-02	1-480288-0
J124B	33-14-02	350444-5
J124B	33-17-02	350444-5
J124C	33-14-02	60618-1
J124C	33-17-02	60618-1
J130A	25-60-01	1-350868-0
J130B	25-60-01	350690-1
J132	25-60-01	03-06-1011
J140	21-52-01	207359-1
J156A	33-20-02	1-480319-0
J156B	33-20-02	60618-1
J157A	33-20-02	1-480319-0
J157B	33-20-02	60619-1
J30A	27-50-02	1-480288-0
J30A	27-50-02	1-480288-0
J30A	33-15-01	1-480288-0
J30A	33-15-02	1-480288-0
J30B	27-50-02	60618-1
J30B	27-50-02	60618-1
J30B	33-15-01	60618-1
J30B	33-15-02	60618-1
J31A	24-33-01	1-480340-0
J31A	24-33-02	1-480340-0
J31A	24-34-01	1-480340-0
J31A	24-34-02	1-480340-0
J31A	33-11-01	1-480340-0
J31A	33-11-02	1-480340-0
J31A	33-11-02	1-480340-0
J31A	33-18-01	1-480340-0
J31A	33-18-01	1-480340-0
J31A	91-22-01	1-480340
J31B	24-33-01	1-480345-0
J31B	24-33-02	1-480345-0
J31B	24-34-01	1-480345-0
J31B	24-34-02	1-480345-0
J31B	33-11-01	1-480345-0
J31B	33-11-02	1-480345-0
J31B	33-11-02	1-480345-0
J31B	33-18-01	60618-1
J31B	33-18-01	60618-1
J31B	91-22-01	1-480345-0
J31C	24-33-01	60618-1
J31C	24-33-02	60618-1
J31C	24-34-01	60618-1
J31C	24-34-02	60618-1
J31C	33-11-01	60618-1
J31C	33-11-02	60618-1

Raytheon Aircraft

BEECH BONANZA WIRING DIAGRAM MANUAL

REFERENCE DESIGNATOR INDEX (CONTINUED)

Reference Designator	GAMA/ATA Code	Part Number
J31C	33-11-02	60618-1
J31C	91-22-01	60618-1
J32	24-40-01	AN2552A3A
J33A	27-31-01	206153-1
J33A	28-40-01	206153-1
J33A	30-30-01	206153-1
J33B	27-31-01	66103-2
J33B	28-40-01	66099-2
J33B	30-30-01	206062-1
J33C	27-31-01	66099-2
J33C	28-40-01	66103-2
J33C	30-30-01	66099-2
J33D	27-31-01	206062-1
J33D	28-40-01	206062-1
J33D	30-30-01	66103-2
J38A	33-40-01	1-480703-0
J38A	33-40-02	1-480703-0
J38A	33-40-02	1-480703-0
J38B	33-40-01	350547-1
J38B	33-40-02	350547-1
J38B	33-40-02	350547-1
J42A	33-44-02	1-480319-0
J42A	33-44-02	1-480319-0
J42A	33-44-02	1-480319-0
J42B	33-44-02	60618-1
J42B	33-44-02	60618-1
J42B	33-44-02	60618-1
J43A	33-44-02	1-480319-0
J43A	33-44-02	1-480319-0
J43A	33-44-02	1-480319-0
J43B	33-44-02	60618-1
J43B	33-44-02	60618-1
J43B	33-44-02	60618-1
J44A	27-50-02	206036-3
J44A	27-50-02	206036-3
J44A	27-51-02	206036-3
J44B	27-50-02	66103-2
J44B	27-50-02	66103-2
J44B	27-51-02	66103-2
J44C	27-50-02	206070-1
J44C	27-50-02	206070-1
J44C	27-51-02	206070-1
J49A	28-20-01	1-480319-0
J49A	28-20-02	1-480319-0
J49A	28-20-04	1-480319-0
J49A	28-20-05	1-480319-0
J49B	28-20-01	60618-1
J49B	28-20-02	60618-1
J49B	28-20-04	60618-1
J49B	28-20-05	60618-1
J50A	28-20-02	1-480319-0
J50A	28-20-05	1-480319-0
J50B	28-20-02	60618-1
J50B	28-20-05	60618-1
J51A	33-10-01	1-480288-0
J51A	33-10-02	1-480288-0
J51A	33-10-02	1-480288-0
J51A	33-10-02	1-480288-0

Reference Designator	GAMA/ATA Code	Part Number
J51B	33-10-01	60618-1
J51B	33-10-02	60618-1
J51B	33-10-02	60618-1
J51B	33-10-02	60618-1
J53A	27-50-02	1-480340-0
J53A	27-50-02	1-480340-0
J53B	27-50-02	60618-1
J53B	27-50-02	60618-1
J53C	27-50-02	60620-1
J53C	27-50-02	60620-1
J54A	24-30-04	206151-2
J54A	24-30-04	206151-2
J54A	24-30-04	206151-2
J54A	24-30-04	206151-2
J54A	27-31-02	206151-2
J54A	27-51-02	206151-2
J54A	32-30-01	206152-1
J54A	32-30-01	206151-2
J54A	32-30-01	206151-2
J54A	32-30-02	206151-2
J54A	32-30-02	206151-2
J54A	32-31-01	206152-1
J54A	32-31-01	206151-2
J54A	32-31-02	206151-2
J54A	32-60-01	206151-2
J54A	32-60-01	206152-1
J54A	32-60-01	206151-2
J54A	32-60-01	206151-2
J54A	32-60-02	206151-2
J54A	33-10-01	206151-2
J54A	33-10-01	206152-1
J54A	33-10-02	206151-2
J54A	33-10-02	206151-2
J54A	33-10-02	206151-2
J54A	34-22-01	206151-2
J54A	91-01-01	206152-1
J54A	91-01-02	206151-2
J54A	91-02-01	206151-2
J54A	91-02-02	206151-2
J54A	91-19-01	206152-1
J54A	91-19-02	205840-3
J54A	91-19-03	206151-2
J54A	91-19-03	206151-2
J54B	24-30-04	206138-1
J54B	24-30-04	206138-1
J54B	24-30-04	206138-1
J54B	24-30-04	206138-1
J54B	27-31-02	206138-1
J54B	27-51-02	206138-1
J54B	32-30-01	1-205202-6
J54B	32-30-01	206138-1
J54B	32-30-01	206138-1
J54B	32-30-02	206138-1
J54B	32-30-02	206138-1
J54B	32-31-01	206070-1
J54B	32-31-01	206138-1
J54B	32-31-02	206138-1
J54B	32-60-01	206138-1
J54B	32-60-01	206070-1

Raytheon Aircraft

BEECH BONANZA WIRING DIAGRAM MANUAL

REFERENCE DESIGNATOR INDEX (CONTINUED)

Reference Designator	GAMA/ATA Code	Part Number
J54B	32-60-01	206138-1
J54B	32-60-02	206138-1
J54B	33-10-01	206138-1
J54B	33-10-01	1-205202-6
J54B	33-10-02	206138-1
J54B	33-10-02	206138-1
J54B	33-10-02	206138-1
J54B	34-22-01	206138-1
J54B	91-01-01	205089-1
J54B	91-01-02	66103-2
J54B	91-02-01	206138-1
J54B	91-02-02	206138-1
J54B	91-19-01	205089-1
J54B	91-19-02	1-205202-6
J54B	91-19-03	66103-2
J54B	91-19-03	66103-2
J54C	24-30-04	66103-2
J54C	24-30-04	66103-2
J54C	24-30-04	66103-2
J54C	24-30-04	66103-2
J54C	27-31-02	66103-2
J54C	27-51-02	66103-2
J54C	32-30-01	206070-1
J54C	32-30-01	66103-2
J54C	32-30-01	66103-2
J54C	32-30-02	66103-2
J54C	32-30-02	66103-2
J54C	32-31-01	1-205202-6
J54C	32-31-01	66103-2
J54C	32-31-02	66103-2
J54C	32-60-01	66103-2
J54C	32-60-01	1-205202-6
J54C	32-60-01	66103-2
J54C	32-60-02	66103-2
J54C	33-10-01	66103-2
J54C	33-10-01	206070-1
J54C	33-10-02	66103-2
J54C	33-10-02	66103-2
J54C	33-10-02	66103-2
J54C	34-22-01	66103-2
J54C	91-01-01	206138-1
J54C	91-01-02	206138-1
J54C	91-02-01	66103-2
J54C	91-02-02	66103-2
J54C	91-19-02	206070-1
J54C	91-19-03	206138-1
J54C	91-19-03	206138-1
J56	32-30-01	206036-3
J56	32-30-02	206036-3
J56	32-31-01	206036-3
J56	32-31-02	206036-3
J56	32-60-01	206036-3
J56A	32-30-01	207018-1
J56A	32-31-02	207018-1
J56A	32-60-01	207018-1
J56B	32-30-01	66103-2
J56B	32-31-02	66103-2
J56B	32-60-01	66103-2

Reference Designator	GAMA/ATA Code	Part Number
J56C	32-30-01	66602-1
J56C	32-31-02	66602-1
J56C	32-60-01	66602-1
J57A	33-20-01	1-480351-0
J57A	33-20-02	1-480319-0
J57B	33-20-01	60618-1
J57B	33-20-02	60618-1
J58A	33-44-01	1-480350-0
J58B	33-44-01	60618-1
J59A	32-60-01	1-480340-0
J59A	32-60-01	1-480340-0
J59B	32-60-01	60618-1
J59B	32-60-01	60618-1
J63A	28-40-01	1-480340-0
J63A	28-40-02	1-480340-0
J63A	28-40-03	1-480340-0
J63B	28-40-01	60618-1
J63B	28-40-02	60618-1
J63B	28-40-03	60618-1
J64A	28-40-01	1-480340-0
J64A	28-40-02	1-480340-0
J64A	28-40-03	1-480340-0
J64B	28-40-01	60618-1
J64B	28-40-02	60618-1
J64B	28-40-03	60618-1
J65A	33-11-01	1-480319-0
J65A	33-11-02	1-480319-0
J65A	33-11-02	1-480319-0
J65B	33-11-01	60617-1
J65B	33-11-02	60617-1
J65B	33-11-02	60617-1
J66A	33-45-01	1-480319-0
J66A	33-45-01	1-480319-0
J66B	33-45-01	60618-1
J66B	33-45-01	60618-1
J67A	33-40-01	1-480351-0
J67A	33-40-02	1-480351-0
J67A	33-40-02	1-480351-0
J67B	33-40-01	60618-1
J67B	33-40-02	60618-1
J67B	33-40-02	60618-1
J69A	33-44-01	1-480319-0
J69A	33-44-02	1-480319-0
J69B	33-44-01	60618-1
J69B	33-44-02	60618-1
J71A	33-44-01	1-480319-0
J71A	33-44-02	1-480319-0
J71A	33-44-02	1-480319-0
J71B	33-44-01	60618-1
J71B	33-44-02	60618-1
J71B	33-44-02	60618-1
J71B	33-44-02	60618-1
J73A	25-10-01	1-480319-0
J73A	25-10-03	1-480319-0
J73B	25-10-01	60620-1
J73B	25-10-03	60620-1
J73C	25-10-01	60618-1

Raytheon Aircraft

BEECH BONANZA WIRING DIAGRAM MANUAL

REFERENCE DESIGNATOR INDEX (CONTINUED)

Reference Designator	GAMA/ATA Code	Part Number
J73C	25-10-03	60618-1
J75A	27-51-01	1-480426-0
J75A	91-01-01	1-480426-0
J75B	27-51-01	60618-1
J75B	91-01-01	60618-1
J77A	33-45-01	1-480351-0
J77A	33-45-01	1-480351-0
J77B	33-45-01	60618-1
J77B	33-45-01	60618-1
J78A	33-45-01	1-480351-0
J78A	33-45-01	1-480351-0
J78B	33-45-01	60618-1
J78B	33-45-01	60618-1
J79A	25-10-01	1-480319-0
J79A	25-10-02	1-480319-0
J79A	25-10-03	1-480319-0
J79B	25-10-01	60620-1
J79B	25-10-02	60620-1
J79B	25-10-03	60620-1
J79C	25-10-01	60618-1
J79C	25-10-02	60618-1
J79C	25-10-03	60618-1
J80	23-01-01	204814-1
J80	24-30-01	204814-1
J80	24-30-01	204814-1
J80	24-30-02	204814-1
J80	24-30-02	204814-1
J80	24-30-03	204814-1
J80	24-30-03	204814-1
J80	24-30-04	204814-1
J80	24-30-04	204814-1
J80	24-31-01	204814-1
J80	25-10-01	204814-1
J80	25-10-02	204814-1
J80	25-10-03	204814-1
J80	25-11-01	204814-1
J80	25-11-02	204814-1
J80	25-12-01	204814-1
J80	25-12-02	204814-1
J80	25-12-03	204814-1
J80	27-32-01	204814-1
J80	27-50-01	204814-1
J80	27-51-01	204814-1
J80	27-51-02	204814-1
J80	28-20-01	204814-1
J80	28-20-02	204814-1
J80	28-40-01	204814-1
J80	28-40-02	204814-1
J80	28-40-03	204814-1
J80	28-40-04	204814-1
J80	28-40-05	204814-1
J80	32-31-01	204814-1
J80	32-31-02	204814-1
J80	32-60-02	204814-1
J80	33-10-01	204814-1
J80	33-10-02	204814-1
J80	33-10-02	204814-1
J80	33-10-02	204814-1

Reference Designator	GAMA/ATA Code	Part Number
J80	33-11-01	204814-1
J80	33-11-02	204814-1
J80	33-11-02	204814-1
J80	33-12-01	204814-1
J80	33-12-02	204814-1
J80	33-12-03	204814-1
J80	33-14-01	204814-1
J80	33-14-02	204814-1
J80	33-14-03	204814-1
J80	33-15-01	204814-1
J80	33-15-02	204814-1
J80	33-16-01	204814-1
J80	33-18-01	204814-1
J80	33-18-01	204814-1
J80	33-20-02	204814-1
J80	34-20-01	204814-1
J80	36-20-02	204814-1
J80	36-20-02	204814-1
J80	73-30-01	204814-1
J80	74-30-01	204814-1
J80	74-30-02	204814-1
J80	77-20-01	204814-1
J80	91-01-01	204814-1
J80	91-01-02	204814-1
J80	91-02-01	204814-1
J80	91-02-02	204814-1
J80	91-15-01	204814-1
J80	91-15-02	204814-1
J81A	21-50-01	206153-1
J81A	32-30-01	206153-1
J81A	32-30-01	206153-1
J81A	32-31-01	206153-1
J81B	21-50-01	66103-2
J81B	32-30-01	66099-2
J81B	32-30-01	66099-2
J81B	32-31-01	66099-2
J81C	21-50-01	206062-1
J82A	32-30-01	206153-1
J82A	32-30-01	206153-1
J82A	32-30-02	206153-1
J82A	32-30-02	206153-1
J82A	32-31-01	206153-1
J82A	32-31-02	206153-1
J82B	32-30-01	206062-1
J82B	32-30-01	206062-1
J82B	32-30-02	206062-1
J82B	32-30-02	206062-1
J82B	32-31-01	206062-1
J82B	32-31-02	206062-1
J82C	32-30-01	66103-2
J82C	32-30-01	66103-2
J82C	32-30-02	66103-2
J82C	32-30-02	66103-2
J82C	32-31-01	66103-2
J82C	32-31-02	66103-2
J85A	32-30-01	1-480288-0
J85A	32-30-01	1-480288-0
J85A	32-30-02	1-480288-0

Raytheon Aircraft

BEECH BONANZA WIRING DIAGRAM MANUAL

REFERENCE DESIGNATOR INDEX (CONTINUED)

Reference Designator	GAMA/ATA Code	Part Number
M25	27-51-02	58-384001-35
M26	25-11-01	58-380077-3
M27	25-12-01	CT2A
M29	28-40-01	58-380051
M29	28-40-02	58-380051
M29	28-40-03	58-380051
M30	28-40-01	58-380051
M30	28-40-02	58-380051
M30	28-40-03	58-380051
M31	30-60-01	90-380007-5
M31	30-60-01	90-380007-7
M31	30-60-01	90-380007-9
M31	30-60-01	90-380007-11
M31	30-60-01	90-380007-5
M31	30-60-01	90-380007-7
M31	30-60-01	90-380007-9
M31	30-60-01	90-380007-11
M38	25-11-02	AT422002
M39	25-12-02	AT4220A4
M39	25-12-03	AT4220A6
M6	73-30-01	36-380071-3
M6	73-30-01	36-380073-3
M6	73-30-01	36-380070-3
M6	73-30-01	36-380072-3
PS11	33-40-01	01-0790079-04
PS11	33-40-01	701571
PS11	33-40-01	60-1750-3
PS11	33-40-02	01-0790079-04
PS11	33-40-02	701571
PS11	33-40-02	60-1750-3
PS11	33-40-02	01-0790079-04
PS11	33-40-02	701571
PS11	33-40-02	60-1750-3
P10A	27-31-02	206037-1
P10A	27-31-02	206037-1
P10A	27-50-01	206036-3
P10A	27-51-01	206037-1
P10A	28-40-02	206037-1
P10A	28-40-03	206037-1
P10A	28-40-04	206037-1
P10A	28-40-05	206037-1
P10A	30-30-02	206037-1
P10A	32-60-01	206037-1
P10A	32-60-01	206037-1
P10A	33-45-01	206037-1
P10A	33-45-01	206037-1
P10A	91-12-01	206037-1
P10A	91-12-02	206037-1
P10A	91-12-02	206037-1
P10B	27-31-02	66101-2
P10B	27-31-02	66101-2
P10B	27-50-01	206070-1
P10B	27-51-01	66101-2
P10B	28-40-02	66101-2
P10B	28-40-03	66101-2
P10B	28-40-04	66101-2
P10B	28-40-05	66101-2
P10B	30-30-02	66101-2

Reference Designator	GAMA/ATA Code	Part Number
P10B	32-60-01	66101-2
P10B	32-60-01	66101-2
P10B	33-45-01	66101-2
P10B	33-45-01	66101-2
P10B	91-12-01	206070-1
P10B	91-12-02	206070-1
P10B	91-12-02	206070-1
P10C	27-31-02	66105-2
P10C	27-31-02	66105-2
P10C	27-50-01	66103-2
P10C	27-51-01	66105-2
P10C	28-40-02	66105-2
P10C	28-40-03	66105-2
P10C	28-40-04	66105-2
P10C	28-40-05	66105-2
P10C	30-30-02	66105-2
P10C	32-60-01	66105-2
P10C	32-60-01	66105-2
P10C	33-45-01	66105-2
P10C	33-45-01	66105-2
P10C	91-12-01	66105-2
P10C	91-12-02	66105-2
P10C	91-12-02	66105-2
P10D	27-31-02	206070-1
P10D	27-31-02	206070-1
P10D	27-50-01	66099-2
P10D	27-51-01	206070-1
P10D	28-40-02	206070-1
P10D	28-40-03	206070-1
P10D	28-40-04	206070-1
P10D	28-40-05	206070-1
P10D	30-30-02	206070-1
P10D	32-60-01	206070-1
P10D	32-60-01	206070-1
P10D	33-45-01	206070-1
P10D	33-45-01	206070-1
P10D	91-12-01	66101-2
P10D	91-12-02	66101-2
P10D	91-12-02	66101-2
P100	33-40-01	CA3106E10SL3S-F80
P100	33-40-02	CA3106E10SL3S-F80
P100	33-40-02	CA3106E10SL3S-F80
P101	33-40-01	CA3106E10SL3S-F80
P101	33-40-02	CA3106E10SL3S-F80
P101	33-40-02	CA3106E10SL3S-F80
P102	33-40-01	CA3106E10SL3S-F80
P102	33-40-02	CA3106E10SL3S-F80
P102	33-40-02	CA3106E10SL3S-F80
P103	33-40-01	CA3106E10SL3S-F80
P103	33-40-02	CA3106E10SL3S-F80
P103	33-40-02	CA3106E10SL3S-F80
P11A	21-50-01	206037-1
P11A	21-50-02	206037-1
P11A	21-50-03	206037-1
P11A	21-50-03	206037-1
P11A	21-50-03	206037-1
P11A	21-50-03	206037-1
P11A	21-50-03	206037-1
P11A	28-40-01	206037-1

Raytheon Aircraft

BEECH BONANZA WIRING DIAGRAM MANUAL

REFERENCE DESIGNATOR INDEX (CONTINUED)

Reference Designator	GAMA/ATA Code	Part Number
P11A	28-40-02	206037-1
P11A	28-40-03	206037-1
P11A	28-40-04	206037-1
P11A	28-40-05	206037-1
P11A	32-60-01	206037-1
P11A	32-60-01	206037-1
P11A	33-45-01	206037-1
P11A	33-45-01	206037-1
P11A	91-13-01	206037-1
P11B	21-50-01	206070-1
P11B	21-50-02	206070-1
P11B	21-50-03	206070-1
P11B	21-50-03	206070-1
P11B	21-50-03	206070-1
P11B	21-50-03	206070-1
P11B	28-40-01	206070-1
P11B	28-40-02	206070-1
P11B	28-40-03	206070-1
P11B	28-40-04	206070-1
P11B	28-40-05	206070-1
P11B	32-60-01	206070-1
P11B	32-60-01	206070-1
P11B	33-45-01	206070-1
P11B	33-45-01	206070-1
P11B	91-13-01	206070-1
P11C	21-50-01	66101-2
P11C	21-50-02	66101-2
P11C	21-50-03	66101-2
P11C	21-50-03	66101-2
P11C	21-50-03	66101-2
P11C	21-50-03	66101-2
P11C	21-50-03	66101-2
P11C	28-40-01	66101-2
P11C	28-40-02	66101-2
P11C	28-40-03	66101-2
P11C	28-40-04	66101-2
P11C	28-40-05	66101-2
P11C	32-60-01	66101-2
P11C	32-60-01	66101-2
P11C	33-45-01	66101-2
P11C	33-45-01	66101-2
P11C	91-13-01	66105-2
P11D	21-50-01	66105-2
P11D	21-50-02	66105-2
P11D	21-50-03	66105-2
P11D	21-50-03	66105-2
P11D	21-50-03	66105-2
P11D	28-40-01	66105-2
P11D	28-40-02	66105-2
P11D	28-40-03	66105-2
P11D	28-40-04	66105-2
P11D	28-40-05	66105-2
P11D	32-60-01	66105-2
P11D	32-60-01	66105-2
P11D	33-45-01	66105-2
P11D	33-45-01	66105-2
P11D	91-13-01	66101-2
P115A	21-50-02	206708-1

Reference Designator	GAMA/ATA Code	Part Number
P115A	32-30-02	206708-1
P115A	32-30-02	206708-1
P115B	21-50-02	206966-1
P115B	32-30-02	206966-1
P115B	32-30-02	206966-1
P115C	21-50-02	66105-2
P115C	32-30-02	66105-2
P115C	32-30-02	66105-2
P116	21-50-03	207442-1
P116	21-50-03	207442-1
P116	21-50-03	207442-1
P116	21-50-03	207442-1
P116	32-30-02	207442-1
P116	32-30-02	207442-1
P116	91-03-01	207442-1
P121A	33-12-02	1-480287-0
P121B	33-12-02	60617-1
P122A	33-12-02	1-480287-0
P122A	33-13-02	1-480287-0
P122B	33-12-02	60617-1
P122B	33-13-02	60617-1
P123A	33-14-02	1-480287-0
P123A	33-17-02	1-480287-0
P123B	33-14-02	60617-1
P123B	33-17-02	60617-1
P124A	33-14-02	1-480287-0
P124A	33-17-02	1-480287-0
P124B	33-14-02	60617-1
P124B	33-17-02	60617-1
P129	23-01-01	JJ-033
P130A	25-60-01	1-350867-0
P130B	25-60-01	350689-1
P131	25-60-01	03-06-2011
P135A	25-11-02	1-480424-0
P135B	25-11-02	60617-5
P140	21-52-01	207360-1
P147A	28-40-04	207377-1
P147A	28-40-05	207377-1
P147B	28-40-04	66105-2
P147B	28-40-05	66105-2
P148A	28-40-04	207377-1
P148A	28-40-05	207377-1
P148B	28-40-04	66105-2
P148B	28-40-05	66105-2
P156A	33-20-02	1-480318-0
P156B	33-20-02	60617-1
P157A	33-20-02	1-480318-0
P157B	33-20-02	60617-1
P16A	32-60-02	207015-1
P16B	32-60-02	66105-2
P16C	32-60-02	206070-1
P17	73-30-01	PT06E14-15S/SR
P18	73-30-01	MS3108E10SL-3S
P18	73-30-01	MS3108F10SL-3S
P21	77-20-01	CA3106E12S3S
P22A	77-20-01	1-480277-0
P22B	77-20-01	60618-1
P23	30-30-01	AN3115-1

Raytheon Aircraft

BEECH BONANZA WIRING DIAGRAM MANUAL

REFERENCE DESIGNATOR INDEX (CONTINUED)

Reference Designator	GAMA/ATA Code	Part Number
P23	30-30-02	AN3115-1
P25	28-20-03	MS3106A-10SL-3S
P30A	27-50-02	1-480287-0
P30A	27-50-02	1-480287-0
P30A	33-15-01	1-480287-0
P30A	33-15-02	1-480287-0
P30B	27-50-02	60617-1
P30B	27-50-02	60617-1
P30B	33-15-01	60617-1
P30B	33-15-02	60617-1
P31A	24-33-01	1-480270-0
P31A	24-33-02	1-480270-0
P31A	24-34-01	1-480270-0
P31A	24-34-02	1-480270-0
P31A	32-60-02	1-480270-0
P31A	33-11-01	1-480270-0
P31A	33-11-02	1-480270-0
P31A	33-11-02	1-480270-0
P31A	33-18-01	1-480270-0
P31A	33-18-01	1-480270-0
P31A	91-22-01	1-480270-0
P31B	24-33-01	1-480283-0
P31B	24-33-02	1-480283-0
P31B	24-34-01	1-480283-0
P31B	24-34-02	1-480283-0
P31B	32-60-02	1-480283-0
P31B	33-11-01	1-480283-0
P31B	33-11-02	1-480283-0
P31B	33-11-02	1-480283-0
P31B	33-18-01	60617-1
P31B	33-18-01	60617-1
P31B	91-22-01	1-480283-0
P31C	24-33-01	60617-1
P31C	24-33-02	60617-1
P31C	24-34-01	60617-1
P31C	24-34-02	60617-1
P31C	32-60-02	60617-1
P31C	33-11-01	60617-1
P31C	33-11-02	60617-1
P31C	33-11-02	60617-1
P31C	91-22-01	60617-1
P31C	91-22-01	60617-1
P33A	27-31-01	206060-1
P33A	28-40-01	206060-1
P33A	30-30-01	206060-1
P33B	27-31-01	206062-1
P33B	28-40-01	66101-2
P33B	30-30-01	206062-1
P33C	27-31-01	66101-2
P33C	28-40-01	66105-2
P33C	30-30-01	66101-2
P33D	27-31-01	66105-2
P33D	28-40-01	206062-1
P33D	30-30-01	66105-2
P35	34-20-01	132325 10SL-3S
P38A	33-40-01	CA3106E10SL-3S-F80
P38A	33-40-01	MS3106E10SL-3S
P38A	33-40-01	1-480702-1

Reference Designator	GAMA/ATA Code	Part Number
P38A	33-40-02	CA3106E10SL3S-F80
P38A	33-40-02	MS3106E10SL-3S
P38A	33-40-02	1-480702-1
P38A	33-40-02	CA3106E10SL3S-F80
P38A	33-40-02	MS3106E10SL-3S
P38A	33-40-02	1-480702-1
P38B	33-40-01	350550-1
P38B	33-40-02	350550-1
P38B	33-40-02	350550-1
P41	30-60-01	132325 20-15S
P41	30-60-01	MS3106R20-15S
P41	30-60-01	132325 20-15S
P41	30-60-01	MS3106R20-15S
P42A	33-44-02	1-480318-0
P42A	33-44-02	1-480318-0
P42A	33-44-02	1-480318-0
P42B	33-44-02	60617-1
P42B	33-44-02	60617-1
P42B	33-44-02	60617-1
P43A	33-44-02	1-480318-0
P43A	33-44-02	1-480318-0
P43A	33-44-02	1-480318-0
P43B	33-44-02	60617-1
P43B	33-44-02	60617-1
P43B	33-44-02	60617-1
P44A	27-50-02	206037-1
P44A	27-50-02	206037-1
P44A	27-51-02	206037-1
P44B	27-50-02	66105-2
P44B	27-50-02	66105-2
P44B	27-51-02	66105-2
P44C	27-50-02	206070-1
P44C	27-50-02	206070-1
P44C	27-51-02	206070-1
P45	24-31-01	MS3106A18-1S
P46	24-33-01	MS3106A18-1S
P46	24-33-02	MS3106A18-1S
P46	24-34-01	MS3106A18-1S
P46	24-34-02	MS3106A18-1S
P49A	28-20-01	1-480318-0
P49A	28-20-02	1-480318-0
P49A	28-20-04	1-480318-0
P49A	28-20-05	1-480318-0
P49B	28-20-01	60617-1
P49B	28-20-02	60617-1
P49B	28-20-04	60617-1
P49B	28-20-05	60617-1
P50A	28-20-02	1-480319-0
P50A	28-20-05	1-480318-0
P50B	28-20-02	60617-1
P50B	28-20-05	60617-1
P51A	33-10-01	1-480287-0
P51A	33-10-02	1-480287-0
P51A	33-10-02	1-480287-0
P51A	33-10-02	1-480287-0
P51B	33-10-01	60617-1
P51B	33-10-02	60617-1
P51B	33-10-02	60617-1

Raytheon Aircraft

BEECH BONANZA WIRING DIAGRAM MANUAL

REFERENCE DESIGNATOR INDEX (CONTINUED)

Reference Designator	GAMA/ATA Code	Part Number
P51B	33-10-02	60617-1
P53A	27-50-02	1-480270-0
P53A	27-50-02	1-480270-0
P53B	27-50-02	60617-1
P53B	27-50-02	60617-1
P53C	27-50-02	60619-1
P53C	27-50-02	60619-1
P54A	24-30-04	206150-1
P54A	24-30-04	206150-1
P54A	24-30-04	206150-1
P54A	24-30-04	206150-1
P54A	27-31-02	206150-1
P54A	27-51-02	206150-1
P54A	32-30-01	205839-3
P54A	32-30-01	206150-1
P54A	32-30-01	206150-1
P54A	32-30-02	206150-1
P54A	32-30-02	206150-1
P54A	32-31-01	205839-3
P54A	32-31-01	206150-1
P54A	32-31-02	206150-1
P54A	32-60-01	206150-1
P54A	32-60-01	205839-3
P54A	32-60-01	206150-1
P54A	32-60-02	206150-1
P54A	33-10-01	206150-1
P54A	33-10-01	205839-3
P54A	33-10-02	206150-1
P54A	33-10-02	206150-1
P54A	33-10-02	206150-1
P54A	34-22-01	206150-1
P54A	91-01-01	205839-3
P54A	91-01-02	206150-1
P54A	91-02-01	206150-1
P54A	91-02-02	206150-1
P54A	91-19-01	205839-3
P54A	91-19-02	205839-3
P54A	91-19-03	206150-1
P54A	91-19-03	206150-1
P54B	24-30-04	206138-1
P54B	24-30-04	206138-1
P54B	24-30-04	206138-1
P54B	27-31-02	206138-1
P54B	27-51-02	206138-1
P54B	32-30-01	205089-1
P54B	32-30-01	206138-1
P54B	32-30-01	206138-1
P54B	32-30-02	206138-1
P54B	32-30-02	206138-1
P54B	32-31-01	205089-1
P54B	32-31-01	206138-1
P54B	32-31-02	206138-1
P54B	32-60-01	206138-1
P54B	32-60-01	205089-1
P54B	32-60-01	206138-1
P54B	32-60-02	206138-1
P54B	33-10-01	206138-1

Reference Designator	GAMA/ATA Code	Part Number
P54B	33-10-01	205089-1
P54B	33-10-02	206138-1
P54B	33-10-02	206138-1
P54B	33-10-02	206138-1
P54B	34-22-01	206138-1
P54B	91-01-01	205090-1
P54B	91-01-02	66105-2
P54B	91-02-01	206138-1
P54B	91-02-02	206138-1
P54B	91-19-01	205090-1
P54B	91-19-02	1-205201-6
P54B	91-19-03	66105-2
P54B	91-19-03	66105-2
P54C	24-30-04	66105-2
P54C	24-30-04	66105-2
P54C	24-30-04	66105-2
P54C	24-30-04	66105-2
P54C	27-31-02	66105-2
P54C	27-51-02	66105-2
P54C	32-30-01	66105-2
P54C	32-30-01	66105-2
P54C	32-30-02	66105-2
P54C	32-30-02	66105-2
P54C	32-31-01	66105-2
P54C	32-31-02	66105-2
P54C	32-60-01	66105-2
P54C	32-60-01	66105-2
P54C	32-60-02	66105-2
P54C	33-10-01	66105-2
P54C	33-10-02	66105-2
P54C	33-10-02	66105-2
P54C	33-10-02	66105-2
P54C	34-22-01	66105-2
P54C	91-01-01	206138-1
P54C	91-01-02	206138-1
P54C	91-02-01	66105-2
P54C	91-02-02	66105-2
P54C	91-19-02	206070-1
P54C	91-19-03	206138-1
P54C	91-19-03	206138-1
P55	77-20-01	AN4076-1
P56	32-30-01	1-480283-0
P56	32-30-02	1-480283-0
P56	32-31-01	1-480283-0
P56	32-31-02	1-480283-0
P56	32-60-01	1-480283-0
P56A	32-30-01	207017-1
P56A	32-30-02	207017-1
P56A	32-31-01	207017-1
P56A	32-31-02	207017-1
P56A	32-60-01	207017-1
P56B	32-30-01	66105-2
P56B	32-30-02	66105-2
P56B	32-31-01	66105-2
P56B	32-31-02	66105-2
P56B	32-60-01	66105-2
P57A	33-20-01	1-480349-0
P57A	33-20-02	1-480318-0

Raytheon Aircraft

BEECH BONANZA WIRING DIAGRAM MANUAL

REFERENCE DESIGNATOR INDEX (CONTINUED)

Reference Designator	GAMA/ATA Code	Part Number
P57B	33-20-01	60617-1
P57B	33-20-02	60617-1
P58A	33-44-01	1-480349-0
P58A	33-44-01	1-480350-0
P58B	33-44-01	60617-1
P58B	33-44-01	60617-1
P59A	32-60-01	1-480270-0
P59A	32-60-01	1-480270-0
P59B	32-60-01	60617-1
P59B	32-60-01	60617-1
P60	33-10-01	MS3106A/B10SL3S
P60	33-10-02	MS3106A/B10SL3S
P60	33-10-02	MS3106A/B10SL3S
P60	33-10-02	MS3106A/B10SL3S
P63A	28-40-01	1-480270-0
P63A	28-40-02	1-480270-0
P63A	28-40-03	1-480270-0
P63B	28-40-01	60617-1
P63B	28-40-02	60617-1
P63B	28-40-03	60617-1
P64A	28-40-01	1-480270-0
P64A	28-40-02	1-480270-0
P64A	28-40-03	1-480270-0
P64B	28-40-01	60617-1
P64B	28-40-02	60617-1
P64B	28-40-03	60617-1
P65A	33-11-01	1-480318-0
P65A	33-11-02	1-480318-0
P65A	33-11-02	1-480318-0
P65B	33-11-01	60618-1
P65B	33-11-02	60618-1
P65B	33-11-02	60618-1
P66A	33-45-01	1-480318-0
P66A	33-45-01	1-480318-0
P66B	33-45-01	60617-1
P66B	33-45-01	60617-1
P67A	33-40-01	1-480349-0
P67A	33-40-02	1-480349-0
P67A	33-40-02	1-480349-0
P67B	33-40-01	60617-1
P67B	33-40-02	60617-1
P67B	33-40-02	60617-1
P69A	33-44-01	1-480318-0
P69A	33-44-02	1-480318-0
P69B	33-44-01	60617-1
P69B	33-44-02	60617-1
P71A	33-44-01	1-480318-0
P71A	33-44-01	1-480350-0
P71A	33-44-02	1-480318-0
P71A	33-44-02	1-480318-0
P71A	33-44-02	1-480318-0
P71B	33-44-01	60617-1
P71B	33-44-01	60617-1
P71B	33-44-02	60617-1
P71B	33-44-02	60617-1
P71B	33-44-02	60617-1
P73A	25-10-01	1-480318-0
P73A	25-10-03	1-480318-0

Reference Designator	GAMA/ATA Code	Part Number
P73B	25-10-01	60617-1
P73B	25-10-03	60617-1
P74A	27-50-01	1-480318-0
P74B	27-50-01	60619-1
P75A	27-51-01	1-480424-0
P75A	91-01-01	1-480424-0
P75B	27-51-01	60617-1
P75B	91-01-01	60617-1
P77A	33-45-01	1-480349-0
P77A	33-45-01	1-480349-0
P77B	33-45-01	60617-1
P77B	33-45-01	60617-1
P78A	33-45-01	1-480349-0
P78A	33-45-01	1-480349-0
P78B	33-45-01	60617-1
P78B	33-45-01	60617-1
P79A	25-10-01	1-480318-0
P79A	25-10-02	1-480318-0
P79A	25-10-03	1-480318-0
P79B	25-10-01	60617-1
P79B	25-10-02	60617-1
P79B	25-10-03	60617-1
P80A	23-01-01	200838-3
P80A	24-30-01	200838-3
P80A	24-30-01	200838-3
P80A	24-30-02	200838-3
P80A	24-30-02	200838-3
P80A	24-30-03	200838-3
P80A	24-30-03	200838-3
P80A	24-30-04	200838-3
P80A	24-30-04	200838-3
P80A	24-30-04	200838-3
P80A	24-30-04	200838-3
P80A	24-30-04	200838-3
P80A	24-30-04	200838-3
P80A	24-31-01	200838-3
P80A	24-33-01	200838-3
P80A	24-33-02	200838-3
P80A	24-34-01	200838-3
P80A	24-34-02	200838-3
P80A	25-10-01	200838-3
P80A	25-10-02	200838-3
P80A	25-10-03	200838-3
P80A	25-11-01	200838-3
P80A	25-11-02	200838-3
P80A	25-12-01	200838-3
P80A	25-12-02	200838-3
P80A	25-12-03	200838-3
P80A	27-32-01	200838-3
P80A	27-50-01	200838-3
P80A	27-51-01	200838-3
P80A	27-51-02	200838-3
P80A	28-20-01	200838-3
P80A	28-20-02	200838-3
P80A	28-40-01	200838-3
P80A	28-40-02	200838-3
P80A	28-40-03	200838-3
P80A	28-40-04	200838-3
P80A	28-40-05	200838-3
P80A	32-31-01	200838-3

Raytheon Aircraft

BEECH BONANZA WIRING DIAGRAM MANUAL

REFERENCE DESIGNATOR INDEX (CONTINUED)

Reference Designator	GAMA/ATA Code	Part Number
P80A	32-31-02	200838-3
P80A	32-60-02	200838-3
P80A	33-10-01	200838-3
P80A	33-10-02	200838-3
P80A	33-10-02	200838-3
P80A	33-10-02	200838-3
P80A	33-11-01	200838-3
P80A	33-11-02	200838-3
P80A	33-11-02	200838-3
P80A	33-12-01	200838-3
P80A	33-12-02	200838-3
P80A	33-12-03	200838-3
P80A	33-14-01	200838-3
P80A	33-14-02	200838-3
P80A	33-14-03	200838-3
P80A	33-15-01	200838-3
P80A	33-15-02	200838-3
P80A	33-16-01	200838-3
P80A	33-18-01	200838-3
P80A	33-18-01	200838-3
P80A	33-20-02	200838-3
P80A	34-20-01	200838-3
P80A	36-20-02	200838-3
P80A	36-20-02	200838-3
P80A	73-30-01	200838-3
P80A	74-30-01	200838-3
P80A	74-30-02	200838-3
P80A	77-20-01	200838-3
P80A	91-01-01	200838-3
P80A	91-01-02	200838-3
P80A	91-02-01	200838-3
P80A	91-02-02	200838-3
P80A	91-15-01	200838-3
P80A	91-15-02	200838-3
P80B	23-01-01	201224-1
P80B	24-30-01	201224-1
P80B	24-30-01	201224-1
P80B	24-30-02	201224-1
P80B	24-30-02	201224-1
P80B	24-30-03	201224-1
P80B	24-30-03	201224-1
P80B	24-30-04	201224-1
P80B	24-30-04	201224-1
P80B	24-30-04	201224-1
P80B	24-31-01	201224-1
P80B	24-33-01	201224-1
P80B	24-33-02	201224-1
P80B	24-34-01	201224-1
P80B	24-34-02	201224-1
P80B	25-10-01	201224-1
P80B	25-10-02	201224-1
P80B	25-10-03	201224-1
P80B	25-11-01	201224-1
P80B	25-11-02	201224-1
P80B	25-12-01	201224-1
P80B	25-12-02	201224-1
P80B	25-12-03	201224-1

Reference Designator	GAMA/ATA Code	Part Number
P80B	27-32-01	201224-1
P80B	27-50-01	201224-1
P80B	27-51-01	201224-1
P80B	27-51-02	201224-1
P80B	28-20-01	201224-1
P80B	28-20-02	201224-1
P80B	28-40-01	201224-1
P80B	28-40-02	201224-1
P80B	28-40-03	201224-1
P80B	28-40-04	201224-1
P80B	28-40-05	201224-1
P80B	32-31-01	201224-1
P80B	32-31-02	201224-1
P80B	32-60-02	201224-1
P80B	33-10-01	201224-1
P80B	33-10-02	201224-1
P80B	33-10-02	201224-1
P80B	33-10-02	201224-1
P80B	33-11-01	201224-1
P80B	33-11-02	201224-1
P80B	33-11-02	201224-1
P80B	33-12-01	201224-1
P80B	33-12-02	201224-1
P80B	33-12-03	201224-1
P80B	33-14-01	201224-1
P80B	33-14-02	201224-1
P80B	33-14-03	201224-1
P80B	33-15-01	201224-1
P80B	33-15-02	201224-1
P80B	33-16-01	201224-1
P80B	33-18-01	201224-1
P80B	33-18-01	201224-1
P80B	33-20-02	201224-1
P80B	34-20-01	201224-1
P80B	36-20-02	201224-1
P80B	36-20-02	201224-1
P80B	73-30-01	201224-1
P80B	74-30-01	201224-1
P80B	74-30-02	201224-1
P80B	77-20-01	201224-1
P80B	91-01-01	201224-1
P80B	91-01-02	201224-1
P80B	91-02-01	201224-1
P80B	91-02-02	201224-1
P80B	91-15-01	206618-1
P80B	91-15-02	206618-1
P80C	23-01-01	201328-1
P80C	24-30-01	201328-1
P80C	24-30-01	201328-1
P80C	24-30-02	201328-1
P80C	24-30-02	201328-1
P80C	24-30-03	201328-1
P80C	24-30-03	201328-1
P80C	24-30-04	201328-1
P80C	24-30-04	201328-1
P80C	24-30-04	201328-1
P80C	24-30-04	201328-1
P80C	24-31-01	201328-1

Raytheon Aircraft

BEECH BONANZA WIRING DIAGRAM MANUAL

REFERENCE DESIGNATOR INDEX (CONTINUED)

Reference Designator	GAMA/ATA Code	Part Number
P80C	24-33-01	201328-1
P80C	24-33-02	201328-1
P80C	24-34-01	201328-1
P80C	24-34-02	201328-1
P80C	25-10-01	201328-1
P80C	25-10-02	201328-1
P80C	25-10-03	201328-1
P80C	25-11-01	201328-1
P80C	25-11-02	201328-1
P80C	25-12-01	201328-1
P80C	25-12-02	201328-1
P80C	25-12-03	201328-1
P80C	27-32-01	201328-1
P80C	27-50-01	201328-1
P80C	27-51-01	201328-1
P80C	27-51-02	201328-1
P80C	28-20-01	201328-1
P80C	28-20-02	201328-1
P80C	28-40-01	201328-1
P80C	28-40-02	201328-1
P80C	28-40-03	201328-1
P80C	28-40-04	201328-1
P80C	28-40-05	201328-1
P80C	32-31-01	201328-1
P80C	32-31-02	201328-1
P80C	32-60-02	201328-1
P80C	33-10-01	201328-1
P80C	33-10-02	201328-1
P80C	33-10-02	201328-1
P80C	33-10-02	201328-1
P80C	33-11-01	201328-1
P80C	33-11-02	201328-1
P80C	33-11-02	201328-1
P80C	33-12-01	201328-1
P80C	33-12-02	201328-1
P80C	33-12-03	201328-1
P80C	33-14-01	201328-1
P80C	33-14-02	201328-1
P80C	33-14-03	201328-1
P80C	33-15-01	201328-1
P80C	33-15-02	201328-1
P80C	33-16-01	201328-1
P80C	33-18-01	201328-1
P80C	33-18-01	201328-1
P80C	33-20-02	201328-1
P80C	34-20-01	201328-1
P80C	36-20-02	201328-1
P80C	36-20-02	201328-1
P80C	73-30-01	201328-1
P80C	74-30-01	201328-1
P80C	74-30-02	201328-1
P80C	77-20-01	201328-1
P80C	91-01-01	201328-1
P80C	91-01-02	201328-1
P80C	91-02-01	201328-1
P80C	91-02-02	201328-1
P80C	91-15-01	201224-1
P80C	91-15-02	201224-1

Reference Designator	GAMA/ATA Code	Part Number
P80D	23-01-01	200333-1
P80D	24-30-01	200333-1
P80D	24-30-01	200333-1
P80D	24-30-02	200333-1
P80D	24-30-02	200333-1
P80D	24-30-03	200333-1
P80D	24-30-03	200333-1
P80D	24-30-04	200333-1
P80D	24-30-04	200333-1
P80D	24-30-04	200333-1
P80D	24-30-04	200333-1
P80D	24-30-04	200333-1
P80D	24-31-01	200333-1
P80D	24-33-01	200333-1
P80D	24-33-02	200333-1
P80D	24-34-01	200333-1
P80D	24-34-02	200333-1
P80D	25-10-01	200333-1
P80D	25-10-02	200333-1
P80D	25-10-03	200333-1
P80D	25-11-01	200333-1
P80D	25-11-02	200333-1
P80D	25-12-01	200333-1
P80D	25-12-02	200333-1
P80D	25-12-03	200333-1
P80D	27-32-01	200333-1
P80D	27-50-01	200333-1
P80D	27-51-01	200333-1
P80D	27-51-02	200333-1
P80D	28-20-01	200333-1
P80D	28-20-02	200333-1
P80D	28-40-01	200333-1
P80D	28-40-02	200333-1
P80D	28-40-03	200333-1
P80D	28-40-04	200333-1
P80D	28-40-05	200333-1
P80D	32-31-01	200333-1
P80D	32-31-02	200333-1
P80D	32-60-02	200333-1
P80D	33-10-01	200333-1
P80D	33-10-02	200333-1
P80D	33-10-02	200333-1
P80D	33-10-02	200333-1
P80D	33-11-01	200333-1
P80D	33-11-02	200333-1
P80D	33-11-02	200333-1
P80D	33-12-01	200333-1
P80D	33-12-02	200333-1
P80D	33-12-03	200333-1
P80D	33-14-01	200333-1
P80D	33-14-02	200333-1
P80D	33-14-03	200333-1
P80D	33-15-01	200333-1
P80D	33-15-02	200333-1
P80D	33-16-01	200333-1
P80D	33-18-01	200333-1
P80D	33-18-01	200333-1
P80D	33-20-02	200333-1
P80D	34-20-01	200333-1

Raytheon Aircraft

BEECH BONANZA WIRING DIAGRAM MANUAL

REFERENCE DESIGNATOR INDEX (CONTINUED)

Reference Designator	GAMA/ATA Code	Part Number
P80D	36-20-02	200333-1
P80D	36-20-02	200333-1
P80D	73-30-01	200333-1
P80D	74-30-01	200333-1
P80D	74-30-02	200333-1
P80D	77-20-01	200333-1
P80D	91-01-01	200333-1
P80D	91-01-02	200333-1
P80D	91-02-01	200333-1
P80D	91-02-02	200333-1
P80D	91-15-01	201328-1
P80D	91-15-02	201328-1
P80E	23-01-01	203618-1
P80E	24-30-01	203618-1
P80E	24-30-01	203618-1
P80E	24-30-02	203618-1
P80E	24-30-02	203618-1
P80E	24-30-03	203618-1
P80E	24-30-03	203618-1
P80E	24-30-04	203618-1
P80E	24-30-04	203618-1
P80E	24-30-04	203618-1
P80E	24-30-04	203618-1
P80E	24-30-04	203618-1
P80E	24-31-01	203618-1
P80E	24-33-01	203618-1
P80E	24-33-02	203618-1
P80E	24-34-01	203618-1
P80E	24-34-02	203618-1
P80E	25-10-01	203618-1
P80E	25-10-02	203618-1
P80E	25-10-03	203618-1
P80E	25-11-01	203618-1
P80E	25-11-02	203618-1
P80E	25-12-01	203618-1
P80E	25-12-02	203618-1
P80E	25-12-03	203618-1
P80E	27-32-01	203618-1
P80E	27-50-01	203618-1
P80E	27-51-01	203618-1
P80E	27-51-02	203618-1
P80E	28-20-01	203618-1
P80E	28-20-02	203618-1
P80E	28-40-01	203618-1
P80E	28-40-02	203618-1
P80E	28-40-03	203618-1
P80E	28-40-04	203618-1
P80E	28-40-05	203618-1
P80E	32-31-01	203618-1
P80E	32-31-02	203618-1
P80E	32-60-02	203618-1
P80E	33-10-01	203618-1
P80E	33-10-02	203618-1
P80E	33-10-02	203618-1
P80E	33-11-01	203618-1
P80E	33-11-02	203618-1
P80E	33-11-02	203618-1
P80E	33-12-01	203618-1

Reference Designator	GAMA/ATA Code	Part Number
P80E	33-12-02	203618-1
P80E	33-12-03	203618-1
P80E	33-14-01	203618-1
P80E	33-14-02	203618-1
P80E	33-14-03	203618-1
P80E	33-15-01	203618-1
P80E	33-15-02	203618-1
P80E	33-16-01	203618-1
P80E	33-18-01	203618-1
P80E	33-18-01	203618-1
P80E	33-18-01	203618-1
P80E	33-20-02	203618-1
P80E	34-20-01	203618-1
P80E	36-20-02	203618-1
P80E	36-20-02	203618-1
P80E	73-30-01	203618-1
P80E	74-30-01	203618-1
P80E	74-30-02	203618-1
P80E	77-20-01	203618-1
P80E	91-01-01	203618-1
P80E	91-01-02	203618-1
P80E	91-02-01	203618-1
P80E	91-02-02	203618-1
P80E	91-15-01	200333-1
P80E	91-15-02	200333-1
P81A	21-50-01	206060-1
P81A	32-30-01	206060-1
P81A	32-30-01	206060-1
P81A	32-31-01	206060-1
P81B	21-50-01	206062-1
P81B	32-30-01	660101-2
P81B	32-30-01	660101-2
P81B	32-31-01	660101-2
P81C	21-50-01	66105-2
P82A	32-30-01	206060-2
P82A	32-30-01	206060-2
P82A	32-30-02	206060-1
P82A	32-31-01	206060-2
P82A	32-31-02	206060-2
P82B	32-30-01	66101-2
P82B	32-30-01	66101-2
P82B	32-30-02	206062-1
P82B	32-30-02	206062-1
P82B	32-31-01	66101-2
P82B	32-31-02	66101-2
P82C	32-30-02	66105-2
P82C	32-30-02	66105-2
P85A	32-30-01	1-480287-0
P85A	32-30-01	1-480287-0
P85A	32-30-02	1-480287-0
P85A	32-30-02	1-480287-0
P85A	32-31-01	1-480287-0
P85A	32-31-02	1-480287-0
P85A	32-60-01	1-480287-0
P85A	32-60-01	1-480287-0
P85A	33-45-01	1-480287-0
P85A	33-45-01	1-480287-0
P85A	91-21-01	1-480287-0

Raytheon Aircraft

BEECH BONANZA WIRING DIAGRAM MANUAL

REFERENCE DESIGNATOR INDEX (CONTINUED)

Reference Designator	GAMA/ATA Code	Part Number
R5	39-10-40	RCR07G103JS
R5	39-10-40	132371B1002EBC
R5	39-10-41	RCR07G102JS
R6	39-10-40	RNC55H4992FS
R6	39-10-40	132373D4992DBD
R6	39-10-41	RNC55H4992FS
R6	39-10-41	132373D4992DBD
R7	39-10-40	RNC55H5622FS
R7	39-10-40	132373D5622DBD
R7	39-10-41	RNC55H5622FS
R7	39-10-41	132373D5622DBD
R75	25-60-01	RH5-150
R8	39-10-40	RNR55C2321FM
R8	39-10-41	RLR07C7500GR
R8	39-10-41	132371B7500EBC
R9	39-10-40	3006P-1-501
R9	39-10-41	3006P-1-102
S10	23-01-01	30-1
S11	28-20-01	35-380053-21
S11	28-20-02	35-380053-21
S11	28-20-03	MS27408-1M
S11	28-20-03	MS27408-1N
S11	28-20-03	MS27408-1N
S11	28-20-04	35-380053-21
S11	28-20-05	35-380053-21
S139	25-60-01	MST205T
S14	74-30-01	35-590099-33
S14	74-30-02	35-590099-33
S16	33-10-01	MS25026-1
S16	33-10-02	MS25026-1
S16	33-10-02	MS25026-1
S18	33-20-01	L18366-3
S18	33-20-02	L18366-3
S19	33-20-01	L18366-3
S19	33-20-02	L18366-3
S20	33-20-01	L18366-3
S20	33-20-02	L18366-3
S21	33-20-01	L18366-3
S21	33-20-02	L18366-3
S22	33-20-01	L18366-3
S22	33-20-02	L18366-3
S23	33-11-01	L18366-5
S23	33-11-02	L18366-5
S23	33-11-02	L18366-5
S28	33-42-01	8410K1
S28	33-42-01	SW442
S28	33-42-01	C5AZ13713A
S29	24-30-01	35-380053-21
S29	24-30-01	35-380053-21
S29	24-30-02	35-380053-21
S29	24-30-02	35-380053-21
S29	24-30-03	35-380053-21
S29	24-30-03	35-380053-21
S29	24-30-04	35-380053-21
S29	24-30-04	35-380053-21
S29	24-30-04	35-380053-21
S29	24-30-04	35-380053-21
S29	24-30-04	35-380053-21
S30A	32-31-01	35-380053-11

Reference Designator	GAMA/ATA Code	Part Number
S30A	32-31-02	35-380053-11
S30B	32-31-01	96-384050-7
S30B	32-31-02	96-384050-7
S31	33-10-01	MST-205T
S31	33-10-01	8858K40
S31	33-10-01	8858K82
S31	33-10-02	8858K82
S31	33-10-02	8858K82
S31	33-10-02	8858K82
S32	32-31-01	35-364171-27
S32	32-31-02	35-364171-27
S33	32-31-01	90-380010-5
S33	32-31-02	90-380010-5
S34	32-31-01	V3-1
S34	32-31-02	V3-1
S35	32-31-01	90-380010-3
S35	32-31-02	90-380010-3
S36	32-30-01	BZ-3AT
S36	32-30-01	BZ-3AT
S36	32-30-02	BZ-3AT
S36	32-30-02	BZ-3AT
S36	32-31-01	MS25026-1
S36	32-31-02	MS25026-1
S37	32-30-01	MS25026-1
S37	32-31-01	MS25026-1
S38	32-30-01	MS25125-E3
S38	32-30-01	8857K44
S38	32-30-01	MS25125-E3
S38	32-30-01	8857K44
S38	32-30-02	8857K44
S38	32-30-02	MS25125-E3
S38	32-30-02	8857K44
S38	32-30-02	MS25125-E3
S39	32-30-01	MS25026-1
S39	32-30-01	MS25008-1
S39	32-30-02	MS25008-1
S39	32-30-02	MS25008-1
S39	32-31-01	MS25026-1
S39	32-31-02	MS25026-1
S39	32-31-02	MS25008-1
S40	32-30-01	MS25026-1
S40	32-30-01	MS25026-1
S40	32-30-02	MS25026-1
S40	32-30-02	MS25026-1
S40	32-31-01	MS25026-1
S40	32-31-02	MS25026-1
S40	32-60-01	MS25026-1
S40	32-60-01	MS25026-1
S41	32-60-01	V3-1
S42	21-50-01	V3-1
S42	21-50-02	V3-1
S42	21-50-03	V3-1
S42	21-50-03	V3-1
S42	21-50-03	V3-1
S42	21-50-03	V3-1
S43	27-31-01	151-10
S43	27-31-02	151-10

Raytheon Aircraft

BEECH BONANZA WIRING DIAGRAM MANUAL

REFERENCE DESIGNATOR INDEX (CONTINUED)

Reference Designator	GAMA/ATA Code	Part Number
S43	27-31-02	151-10
S45	32-30-01	MS25026-1
S45	32-30-01	MS25026-1
S45	32-30-02	MS25026-1
S45	32-30-02	MS25026-1
S45	32-31-02	MS25026-1
S45	32-60-01	MS25026-1
S45	32-60-01	MS25026-1
S46	27-32-01	MST-105D
S47	27-50-02	MS25026-1
S47	27-50-02	MS25026-1
S48	27-32-01	26006
S50	27-50-01	MS25026-1
S50	27-50-02	MS25026-1
S51	27-50-01	MS25026-1
S51	27-50-02	MS25026-1
S51	27-50-02	MS25006-1
S52	27-50-01	MS25126-B1
S52	27-50-02	8858K82
S52	27-50-02	8858K82
S53	28-20-03	MS24659-23D
S54	28-20-03	E45C-55
S55	24-33-01	35-380053-9
S55	24-33-02	35-380053-9
S56	24-33-01	35-380053-11
S56	24-33-02	35-380053-11
S56	24-34-01	35-380053-11
S56	24-34-02	35-380053-11
S57	33-10-01	60-389012-9
S57	33-10-02	60-389012-9
S57	33-10-02	60-389012-9
S57	33-10-02	60-389012-9
S58	32-60-02	ISE1-6
S59	27-50-02	MS25026-1
S60	32-60-01	100-381006-1
S60	32-60-01	100-381006-1
S61	32-60-01	100-381006-1
S61	32-60-01	100-381006-1
S62	32-60-01	100-381006-1
S62	32-60-01	100-381006-1
S63	32-60-01	100-381006-1
S63	32-60-01	100-381006-1
S64	21-50-01	100-381006-1
S64	21-50-02	100-381006-1
S64	21-50-03	100-381006-1
S64	21-50-03	100-381006-1
S64	21-50-03	100-381006-1
S64	21-50-03	100-381006-1
S64	32-60-01	100-381006-1
S64	32-60-01	100-381006-1
S65	32-60-01	100-381006-1
S65	32-60-01	100-381006-1
S67	33-10-01	MS25026-1
S67	33-10-02	MS25026-1
S67	33-10-02	MS25026-1
S67	33-10-02	MS25026-1
S68	21-50-01	MS25026-1
S68	21-50-02	MS25026-1

Reference Designator	GAMA/ATA Code	Part Number
S68	21-50-03	MS25026-1
S68	21-50-03	MS25026-1
S68	21-50-03	MS25026-1
S68	21-50-03	MS25026-1
S71	21-50-01	MS27407-1
S71	21-50-02	MS27407-1
S71	21-50-03	MS27407-1
S71	21-50-03	MS27407-1
S71	21-50-03	MS27407-1
S71	21-50-03	MS27407-1
S71	21-50-03	MS27407-1
S73A	21-50-01	002-361013-47
S73A	21-50-02	002-361013-47
S73A	32-30-02	002-361013-55
S73A	32-30-02	002-361013-55
S73A	32-31-02	002-361013-47
S73B	21-50-01	MS25008-1
S73B	21-50-02	MS25008-1
S73B	32-30-02	MS25008-1
S73B	32-30-02	MS25008-1
S73B	32-31-02	MS25008-1
S73C	21-50-01	MCD2711
S73C	21-50-02	MCD2711
S73C	32-30-02	MCD2711
S73C	32-30-02	MCD2711
S73C	32-31-02	MCD2711
S74	21-50-01	76575-7
S74	21-50-02	M4008-7
S74	21-50-03	M4008-7
S74	21-50-03	M4008-7
S74	21-50-03	M4008-7
S74	21-50-03	M4008-7
S74	21-50-03	76575-7
S75	21-50-01	101-380002-3
S75	21-50-02	101-380002-3
S75	21-50-03	101-380002-3
S75	21-50-03	101-380002-3
S75	21-50-03	101-380002-3
S76	27-50-02	MS25026-1
S76	27-50-02	BZ-3AT
S77	34-22-01	25530-1.5
S77	34-22-01	36-324096-19
S77	34-22-01	M4007-1.5
S77	36-20-02	M4007-1.5
S77	36-20-02	M4007-1.5
S78	32-30-01	A5-103-1031
S78	32-30-02	A5-103-1031
TB11A	33-12-01	204228-2
TB11B	33-12-01	203669-6
TB12A	33-12-01	204228-2
TB12A	33-13-01	204228-2
TB12B	33-12-01	203669-6
TB12B	33-13-01	203669-6
TB13A	33-14-01	204228-2
TB13A	33-17-01	204228-2
TB13B	33-14-01	203669-6
TB13B	33-17-01	203669-6
TB14A	33-14-01	204228-2
TB14A	33-17-01	204228-2

Raytheon Aircraft

BEECH BONANZA WIRING DIAGRAM MANUAL

REFERENCE DESIGNATOR INDEX (CONTINUED)

Reference Designator	GAMA/ATA Code	Part Number
TB14B	33-14-01	203669-6
TB14B	33-17-01	203669-6
TB15	24-34-01	MS27212-2-2
TB15	24-34-02	MS27212-2-2
TB15	24-52-01	MS27212-2-2
TB15	24-52-02	MS27212-2-2
TB15	24-52-02	MS27212-2-2
TB16	33-13-03	M81714/7-AA1
TB17	33-17-03	M81714/7-AA1
TB18	33-12-03	M81714/7-AB1
TB19	33-14-03	M81714/7-AB1
TB20	33-14-03	M81714/2-AB1
TC10	77-30-01	MCI-A106-B
U1	39-10-40	CA124G
U1	39-10-41	CA124G
U1A	39-10-40	
U1B	39-10-40	
U1C	39-10-40	
U1D	39-10-40	
VR11	24-31-01	36-380056-5
VR11	24-31-01	36-380096-1
VR12	24-33-01	36-380056-1
VR12	24-33-02	36-380056-1
VR12	24-33-02	36-380056-3
VR12	24-34-01	36-380056-1
VR12	24-34-02	36-380056-3
W1	39-10-40	58-364059-1
W1	39-10-41	58-364059-1
W10	33-40-01	M7078/3-16-3
W10	33-40-02	M7078/3-16-3
W10	33-40-02	M7078/3-16-3
W11	24-30-01	002-369014-3
W11	24-30-01	002-369014-3
W11	24-30-02	002-369014-3
W11	24-30-02	002-369014-3
W11	24-30-03	002-369014-3
W11	24-30-03	002-369014-3
W12	24-50-01	114931-1-6
W12	24-50-02	114931-1-6
W12	24-50-02	114931-1-6
W12	24-51-01	114931-1-6
W12	24-51-02	114931-1-6
W12	24-51-02	114931-1-6
W12	24-52-01	114931-1-6
W12	24-52-02	114931-1-6
W12	24-52-02	114931-1-6
W12	24-52-02	114931-1-6
W12	30-30-01	114931-1-6
W12	30-30-02	114931-1-6
W12	30-60-01	114931-1-6
W12	30-60-01	114931-1-6
W12	33-11-01	114931-1-6
W12	33-11-02	114931-1-6
W12	33-11-02	114931-1-6
W12	33-40-01	114931-1-6
W12	33-40-02	114931-1-6
W12	33-40-02	114931-1-6
W12	33-43-01	114931-1-6
W12	33-44-01	114931-1-6

Reference Designator	GAMA/ATA Code	Part Number
W12	33-44-02	114931-1-6
W12	33-44-02	114931-1-6
W12	33-44-02	114931-1-6
W12	33-45-01	114931-1-6
W12	33-45-01	114931-1-6
W12	33-46-01	114931-1-6
W13	24-50-01	114931-1-12
W13	24-50-02	114931-1-12
W13	24-50-02	114931-1-12
W13	27-31-01	114931-1-12
W13	27-31-02	114931-1-12
W13	27-31-02	114931-1-12
W13	28-40-01	114931-1-12
W13	28-40-02	114931-1-12
W13	28-40-03	114931-1-12
W13	32-30-01	114931-12
W13	32-30-02	114931-12
W13	32-30-02	114931-12
W13	32-31-02	114931-1-12
W13	32-60-01	114931-12
W13	32-60-01	114931-12
W13	33-10-02	114931-1-12
W13	33-10-02	114931-1-12
W13	33-10-02	114931-1-12
W13	33-11-01	114931-1-12
W13	33-15-01	114931-1-12
W13	33-15-02	114931-12
W13	33-20-01	114931-1-12
W13	33-20-02	114931-1-12
W13	36-20-02	114931-1-12
W13	36-20-02	114931-1-12
W14	24-50-01	114931-1-2
W14	24-50-02	114931-1-2
W14	24-50-02	114931-1-2
W14	24-51-01	114931-1-2
W14	24-51-02	114931-1-2
W14	24-51-02	114931-1-2
W14	24-52-01	114931-1-2
W14	24-52-02	114931-1-2
W14	24-52-02	114931-1-2
W16	24-33-01	114931-1-4
W16	24-33-02	114931-1-4
W16	24-34-01	114931-1-4
W16	24-51-01	114931-1-4
W16	24-51-02	114931-1-4
W16	24-51-02	114931-1-4
W16	24-51-02	114931-1-4
W17	24-33-01	114931-1-3
W17	24-33-02	114931-1-3
W17	24-34-01	114931-1-3
W17	24-34-02	114931-1-3
W17	24-51-01	114931-1-3
W17	24-51-02	114931-1-3
W17	24-51-02	114931-1-3
W17	24-51-02	114931-1-3
W17	24-52-01	114931-1-3
W18	24-51-01	114931-1-7
W18	24-51-02	114931-1-7
W18	24-51-02	114931-1-7
W18	24-52-01	114931-1-7

Raytheon Aircraft

BEECH BONANZA WIRING DIAGRAM MANUAL

REFERENCE DESIGNATOR INDEX (CONTINUED)

Reference Designator	GAMA/ATA Code	Part Number
XDS109	33-20-02	2565
XDS112	33-13-01	A8970B2
XDS112	33-13-02	A8970B2
XDS112	33-13-03	A8970B2
XDS113	33-13-01	A8970B2
XDS113	33-13-02	A8970B2
XDS113	33-13-03	A8970B2
XDS114	33-13-01	A8970B2
XDS114	33-13-02	A8970B2
XDS114	33-13-03	A8970B2
XDS115	33-13-01	A8970B2
XDS115	33-13-02	A8970B2
XDS115	33-13-03	A8970B2
XDS116	33-13-01	A8970B2
XDS116	33-13-02	A8970B2
XDS116	33-13-03	A8970B2
XDS117	33-13-01	A8970B2
XDS117	33-13-02	A8970B2
XDS117	33-13-03	A8970B2
XDS118	33-13-01	A8970B2
XDS118	33-13-02	A8970B2
XDS118	33-13-03	A8970B2
XDS119	33-17-01	A8970B2
XDS119	33-17-02	A8970B2
XDS119	33-17-03	A8970B2
XDS121	33-10-02	855291SI-G-5-DS-P6
XDS144	32-60-01	855291SI-R2DS-P6
XDS144	32-60-01	855291SI-R2DS-P6
XDS145	32-60-01	855291SI-G5STD
XDS145	32-60-01	855291SI-G5STD
XDS146	32-60-01	855291SI-G5STD
XDS146	32-60-01	855291SI-G5STD
XDS147	32-60-01	855291SI-G5STD
XDS147	32-60-01	855291SI-G5STD
XDS148	32-60-02	WCD421-ABE02
XDS151	33-10-02	855291SIA4DSP6
XDS151	33-10-02	855291SI-A-4-DS-P6
XDS152	33-10-02	855291SI-2-DS-P6
XDS152	33-10-02	855291SI-R-2-DS-P6
XDS17	33-11-01	96-364090-11
XDS17	33-11-02	96-364090-11
XDS17	33-11-02	96-364090-11
XDS18	33-11-01	A6745B
XDS18	33-11-02	A6745B
XDS18	33-11-02	A6745B
XDS23	33-45-01	A1815A-6-7512
XDS23	33-45-01	A1815A-6-7512
XDS25	33-45-01	A1815A-R-7512
XDS25	33-45-01	A1815A-R-7512
XDS26	33-10-02	855291S1R2DSP6
XDS26	33-10-02	855291SI-2-DS-P6
XDS26	33-10-02	855291SI-R-2-DS-P6
XDS28	33-18-01	4169-143
XDS28	33-18-01	4169-143
XDS29	33-18-01	4169-143
XDS29	33-18-01	4169-143
XDS30	24-33-01	4169-143
XDS30	24-33-02	4169-143

Reference Designator	GAMA/ATA Code	Part Number
XDS30	24-34-01	4169-143
XDS30	24-34-02	4169-143
XDS30	33-18-01	4169-143
XDS30	33-18-01	4169-143
XDS31	33-18-01	4169-143
XDS31	33-18-01	4169-143
XDS32	33-18-01	4169-143
XDS32	33-18-01	4169-143
XDS33	33-18-01	4169-143
XDS33	33-18-01	4169-143
XDS34	33-18-01	4169-143
XDS34	33-18-01	4169-143
XDS35	33-18-01	4169-143
XDS35	33-18-01	4169-143
XDS36	33-18-01	4169-143
XDS36	33-18-01	4169-143
XDS37	33-18-01	4169-143
XDS37	33-18-01	4169-143
XDS38	33-18-01	4169-143
XDS38	33-18-01	4169-143
XDS39	33-18-01	4169-143
XDS39	33-18-01	4169-143
XDS42	33-42-01	2506
XDS43	33-42-01	2506
XDS45	33-10-01	855291SIR2DS-P6
XDS45	33-10-02	855291SIR2DSP6
XDS45	33-10-02	855291SI-2-DS-P6
XDS45	33-10-02	855291SI-R-2-DS-P6
XDS5	36-20-02	MS25041-6
XDS5	36-20-02	MS25041-6
XDS53	33-14-01	PL-1
XDS53	33-14-02	PL-1
XDS53	33-14-03	PL-1
XDS53	33-17-02	PL-1
XDS53	33-17-03	PL-1
XDS53	33-18-01	PL-1
XDS53	33-18-01	PL-1
XDS6	36-20-02	MS25041-4
XDS6	36-20-02	MS25041-4
XDS65	33-17-01	A8970B2
XDS65	33-17-02	A8970B2
XDS65	33-17-03	A8970B2
XDS66	33-17-01	A8970B2
XDS66	33-17-02	A8970B2
XDS66	33-17-03	A8970B2
XDS67	33-17-01	A8970B2
XDS67	33-17-02	A8970B2
XDS67	33-17-03	A8970B2
XDS68	33-17-01	A8970B2
XDS68	33-17-02	A8970B2
XDS68	33-17-03	A8970B2
XDS69	33-17-01	A8970B2
XDS69	33-17-02	A8970B2
XDS69	33-17-03	A8970B2
XDS70	33-17-01	A8970B2
XDS70	33-17-02	A8970B2
XDS70	33-17-03	A8970B2
XDS71	33-17-01	A8970B2

Raytheon Aircraft

BEECH BONANZA WIRING DIAGRAM MANUAL

REFERENCE DESIGNATOR INDEX (CONTINUED)

Reference Designator	GAMA/ATA Code	Part Number
XDS71	33-17-02	A8970B2
XDS71	33-17-03	A8970B2
XDS72	33-17-01	A8970B2
XDS72	33-17-02	A8970B2
XDS72	33-17-03	A8970B2
XDS73	33-17-01	A8970B2
XDS73	33-17-02	A8970B2
XDS73	33-17-03	A8970B2
XDS74	33-17-01	A8970B2
XDS74	33-17-02	A8970B2
XDS74	33-17-03	A8970B2
XDS77	33-17-01	A8970B2
XDS77	33-17-02	A8970B2
XDS77	33-17-03	A8970B2
XDS78	33-17-01	A8970B2
XDS78	33-17-02	A8970B2
XDS78	33-17-03	A8970B2
XDS79	33-17-01	A8970B2
XDS79	33-17-02	A8970B2
XDS79	33-17-03	A8970B2
XDS80	33-17-01	A8970B2
XDS80	33-17-02	A8970B2
XDS80	33-17-03	A8970B2
XDS95	33-11-01	A6795B
XDS95	33-11-02	A6795B
XDS95	33-11-02	A6795B
XDS96	33-11-01	A6795B
XDS96	33-11-02	A6795B
XDS96	33-11-02	A6795B
XDS97	33-10-01	855291SIR2DS-P6
XDS97	33-10-02	855291SIR2DSP6
XDS97	33-10-02	855291SI-2-DS-P6
XDS97	33-10-02	855291SI-R-2-DS-P6
XF1	24-30-02	FSH
XF1	24-30-02	FSH
XF1	24-30-03	FSH
XF1	24-30-03	FSH
XF1	24-30-04	FSH
XF1	24-30-04	FSH
XF1	24-30-04	FSH
XF1	24-30-04	FSH
XF1	24-30-04	FSH
XF11	24-33-01	4522
XF11	24-33-02	4522
XF11	24-34-01	4522
XF11	24-34-02	4522
XF15	24-30-01	4532
XF15	24-30-01	4532
XF15	24-30-02	4532
XF15	24-30-02	4532
XF15	24-30-03	4532
XF15	24-30-03	4532
XF15	24-30-03	4532
XF15	24-30-04	4532
XF15	24-30-04	4532
XF15	24-30-04	4532
XF15	24-30-04	4532
XF15	24-30-04	4532
XF15	25-11-01	4532
XF15	25-11-02	4532
XF15	25-12-01	4532

Reference Designator	GAMA/ATA Code	Part Number
XF15	25-12-02	4532
XF15	25-12-03	4532
XF19	21-50-01	4532
XF19	21-50-02	4532
XF19	21-50-03	4532
XF19	21-50-03	4532
XF19	21-50-03	4532
XF19	21-50-03	4532
XF19	21-50-03	4532
XF19	33-42-01	4532
XF2	24-30-01	FSH
XF2	24-30-01	FSH
XF2	24-30-02	FSH
XF2	24-30-02	FSH
XF2	24-30-03	FSH
XF2	24-30-03	FSH
XF2	24-30-04	FSH
XF2	24-30-04	FSH
XF2	24-30-04	FSH
XF2	24-30-04	FSH
XF26	24-30-03	60-369025-2
XF26	24-30-03	60-369025-2
XF26	24-30-04	60-369025-2
XF26	24-30-04	60-369025-2
XF26	24-30-04	60-369025-2
XF26	24-30-04	60-369025-2
XF3	24-30-01	FSH
XF3	24-30-01	FSH
XF3	24-30-02	FSH
XF3	24-30-02	FSH
XF3	24-30-03	FSH
XF3	24-30-03	FSH
XF3	24-30-04	FSH
XF3	24-30-04	FSH
XF3	24-30-04	FSH
XF3	24-30-04	FSH
XF3	24-30-04	FSH
XF3A	24-30-01	FSH
XF3A	24-30-02	FSH
XF3B	24-30-01	FSH
XF3B	24-30-02	FSH
XF3C	24-30-01	FSH
XF3C	24-30-02	FSH
XF3D	24-30-01	FSH
XF3D	24-30-02	FSH
XF3E	24-30-01	FSH
XF3E	24-30-02	FSH
XF3F	24-30-02	FSH
XF30	36-20-02	4522
XF30	36-20-02	4522
XF31	24-30-03	HDJ-A
XF31	24-30-03	HHJ-A
XF31	24-30-03	HDJ-A
XF31	24-30-03	HHJ-A
XF31	24-30-04	HDJ-A
XF31	24-30-04	HHJ-A
XF32	24-30-04	58-361015
XF33	34-22-01	4522
Y1A	24-30-01	FSH
Y1A	24-30-02	FSH

Raytheon Aircraft

BEECH BONANZA WIRING DIAGRAM MANUAL

REFERENCE DESIGNATOR INDEX (CONTINUED)

Reference Designator	GAMA/ATA Code	Part Number
Y1A	24-30-03	
Y1A	24-30-04	
Y1B	24-30-01	55-3025-1S
Y1B	24-30-02	55-3025-1S
Y1B	24-30-03	55-3025-1S
Y1B	24-30-04	55-3025-1S
Y1C	24-30-01	58-360006-1
Y1C	24-30-02	58-360006-1
Y1C	24-30-03	58-360006-1
Y1C	24-30-04	58-360006-1
Y1D	24-30-01	58-361015-1

Reference Designator	GAMA/ATA Code	Part Number
Y1D	24-30-02	58-361015-1
Y1D	24-30-03	58-361015-1
Y1D	24-30-04	58-361015-1
Y1E	24-30-01	WF2K10R
Y1E	24-30-02	WF2K10R
Y1E	24-30-03	WF2K10R
Y1E	24-30-04	WF2K10R
Y1F	24-30-01	9505-08
Y1F	24-30-02	9505-08
Y1F	24-30-03	9505-08
Y1F	24-30-04	9505-08

**PART
NUMBER
INDEX**

Raytheon Aircraft

BEECH BONANZA WIRING DIAGRAM MANUAL

PART NUMBER INDEX

LIST OF PAGE EFFECTIVITY

SECTION	PAGE	DATE
PART NUMBER INDEX - EFFECTIVITY	1	01/29/99
PART NUMBER INDEX	1 thru 37	01/29/99 01/29/99

Raytheon Aircraft

BEECH BONANZA WIRING DIAGRAM MANUAL

PART NUMBER INDEX

Part Number	GAMA/ATA Code	Reference Designator
AGC-15	24-33-01	F11
AGC-15	24-33-02	F11
AGC-15	24-34-01	F11
AGC-15	24-34-02	F11
AGC5	21-50-01	F19
AGC5	21-50-01	F20
AGC5	21-50-02	F19
AGC5	21-50-02	F20
AGC5	21-50-03	F19
AGC5	21-50-03	F20
AGC5	21-50-03	F19
AGC5	21-50-03	F20
AGC5	21-50-03	F19
AGC5	21-50-03	F20
AGC5	21-50-03	F19
AGC5	21-50-03	F20
AGC5	24-30-01	F15
AGC5	24-30-01	F16
AGC5	24-30-01	F15
AGC5	24-30-01	F16
AGC5	24-30-02	F15
AGC5	24-30-02	F16
AGC5	24-30-02	F15
AGC5	24-30-02	F16
AGC5	24-30-03	F15
AGC5	24-30-03	F16
AGC5	24-30-03	F26
AGC5	24-30-03	F31
AGC5	24-30-03	F15
AGC5	24-30-03	F16
AGC5	24-30-03	F26
AGC5	24-30-03	F31
AGC5	24-30-04	F15
AGC5	24-30-04	F16
AGC5	24-30-04	F26
AGC5	24-30-04	F31
AGC5	24-30-04	F15
AGC5	24-30-04	F16
AGC5	24-30-04	F26
AGC5	24-30-04	F15
AGC5	24-30-04	F16
AGC5	24-30-04	F26
AGC5	25-11-01	F28
AGC5	25-11-02	F28
AGC5	25-12-01	F28
AGC5	25-12-02	F28
AGC5	25-12-03	F28
AGC5	33-42-01	F22
AGC5	34-22-01	F33
AGC5	36-20-02	F30
AGC5	36-20-02	F30
ALT9422	24-30-01	G18
ALT9422	24-30-01	G18
ALT9422	24-30-02	G18
ALT9422	24-30-02	G18

Part Number	GAMA/ATA Code	Reference Designator
ALT9422	24-30-03	G18
ALT9422	24-30-03	G18
ALV9407	24-30-01	G18
ALV9407	24-30-01	G18
ALV9407	24-30-02	G18
ALV9407	24-30-02	G18
AN2552A3A	24-40-01	J32
AN3-5A	24-30-02	GS4
AN3-5A	24-30-02	GS4
AN3-5A	24-30-03	GS4
AN3-5A	24-30-03	GS4
AN3-5A	24-30-04	GS4
AN3-5A	24-30-04	GS4
AN3-5A	24-30-04	GS4
AN3-5A	24-30-04	GS4
AN3-5A	24-30-04	GS4
AN3-5A	33-43-01	GS4A
AN3115-1	30-30-01	P23
AN3115-1	30-30-02	P23
AN4076-1	77-20-01	P55
AN5546-1	77-20-01	RT13
AN960-10	33-43-01	GS2B
AN960-10L	33-43-01	GS4B
AT4220A4	25-12-02	M39
AT4220A6	25-12-03	M39
AT422002	25-11-02	M38
A1437	21-50-01	FL1
A1437	21-50-01	FL2
A1437	21-50-02	FL1
A1437	21-50-02	FL2
A1437	21-50-03	FL1
A1437	21-50-03	FL2
A1437	21-50-03	FL1
A1437	21-50-03	FL2
A1437	21-50-03	FL1
A1437	21-50-03	FL2
A1437	21-50-03	FL1
A1437	21-50-03	FL2
A1437	21-50-03	FL1
A1437	21-50-03	FL2
A1437	27-32-01	FL11
A1437	27-32-01	FL12
A1815A-R-7512	33-45-01	XDS25
A1815A-R-7512	33-45-01	XDS25
A1815A-6-7512	33-45-01	XDS23
A1815A-6-7512	33-45-01	XDS23
A2064-1683	33-45-01	DS22
A2064-1683	33-45-01	DS22
A457A	33-40-02	DS11E
A457A	33-40-02	DS11E
A457A-0	33-40-02	DS11F
A457A-0	33-40-02	DS11F
A5-103-1031	32-30-01	S78
A5-103-1031	32-30-02	S78
A500A-B28	33-40-02	DS11A
A500A-B28	33-40-02	DS11A
A506	33-40-02	DS11B
A506	33-40-02	DS11B
A508	33-40-02	DS11D
A508	33-40-02	DS11D
A510	33-40-02	DS11C

Raytheon Aircraft

BEECH BONANZA WIRING DIAGRAM MANUAL

PART NUMBER INDEX (CONTINUED)

Part Number	GAMA/ATA Code	Reference Designator
A510	33-40-02	DS11C
A6745B	33-11-01	XDS18
A6745B	33-11-02	XDS18
A6745B	33-11-02	XDS18
A6795B	33-11-01	XDS95
A6795B	33-11-01	XDS96
A6795B	33-11-02	XDS95
A6795B	33-11-02	XDS96
A6795B	33-11-02	XDS95
A6795B	33-11-02	XDS96
A7079B24	33-44-01	DS140C
A7079B24	33-44-01	DS140C
A7079B24	33-44-01	DS141C
A7079B24	33-44-02	DS140C
A7079B24	33-44-02	DS140S
A7079B24	33-44-02	DS141C
A7079B24	33-44-02	DS141C
A7079B24	33-44-02	DS141S
A7079B24	33-44-02	DS141Y
A7079B24	33-44-02	DS140C
A7079B24	33-44-02	DS140S
A7079B24	33-44-02	DS141C
A7079B24	33-44-02	DS141C
A7079B24	33-44-02	DS141Y
A7079B24	33-44-02	DS140C
A7079B24	33-44-02	DS141J
A7079B24	33-44-02	DS141J
A7079B24	33-44-02	DS141ZA
A7512-24	33-45-01	DS23
A7512-24	33-45-01	DS25
A7512-24	33-45-01	DS23
A7512-24	33-45-01	DS25
A7632	33-44-01	DS140E
A7632	33-44-01	DS141E
A7632	33-44-02	DS140E
A7632	33-44-02	DS141E
A7632	33-44-02	DS141E
A7632	33-44-02	DS140E
A7632	33-44-02	DS141E
A7632	33-44-02	DS140E
A7632	33-44-02	DS141L
A7632	33-44-02	DS141L
A7942	33-44-01	DS140D
A7942	33-44-01	DS141D
A7942	33-44-02	DS140D
A7942	33-44-02	DS141D
A7942	33-44-02	DS141D
A7942	33-44-02	DS140D
A7942	33-44-02	DS141D
A7942	33-44-02	DS141D
A7942	33-44-02	DS140D
A7942	33-44-02	DS141K
A7942	33-44-02	DS141K
A8970B2	33-13-01	XDS112
A8970B2	33-13-01	XDS113
A8970B2	33-13-01	XDS114
A8970B2	33-13-01	XDS115

Part Number	GAMA/ATA Code	Reference Designator
A8970B2	33-13-01	XDS116
A8970B2	33-13-01	XDS117
A8970B2	33-13-01	XDS118
A8970B2	33-13-02	XDS112
A8970B2	33-13-02	XDS113
A8970B2	33-13-02	XDS114
A8970B2	33-13-02	XDS115
A8970B2	33-13-02	XDS116
A8970B2	33-13-02	XDS117
A8970B2	33-13-02	XDS118
A8970B2	33-13-03	XDS112
A8970B2	33-13-03	XDS113
A8970B2	33-13-03	XDS114
A8970B2	33-13-03	XDS115
A8970B2	33-13-03	XDS116
A8970B2	33-13-03	XDS117
A8970B2	33-13-03	XDS118
A8970B2	33-14-01	XDS101
A8970B2	33-14-02	XDS101
A8970B2	33-14-03	XDS101
A8970B2	33-17-01	XDS101
A8970B2	33-17-01	XDS102
A8970B2	33-17-01	XDS119
A8970B2	33-17-01	XDS65
A8970B2	33-17-01	XDS66
A8970B2	33-17-01	XDS67
A8970B2	33-17-01	XDS68
A8970B2	33-17-01	XDS69
A8970B2	33-17-01	XDS70
A8970B2	33-17-01	XDS71
A8970B2	33-17-01	XDS72
A8970B2	33-17-01	XDS73
A8970B2	33-17-01	XDS74
A8970B2	33-17-01	XDS77
A8970B2	33-17-01	XDS78
A8970B2	33-17-01	XDS79
A8970B2	33-17-01	XDS80
A8970B2	33-17-02	XDS101
A8970B2	33-17-02	XDS119
A8970B2	33-17-02	XDS65
A8970B2	33-17-02	XDS66
A8970B2	33-17-02	XDS67
A8970B2	33-17-02	XDS68
A8970B2	33-17-02	XDS69
A8970B2	33-17-02	XDS70
A8970B2	33-17-02	XDS71
A8970B2	33-17-02	XDS72
A8970B2	33-17-02	XDS73
A8970B2	33-17-02	XDS74
A8970B2	33-17-02	XDS77
A8970B2	33-17-02	XDS78
A8970B2	33-17-02	XDS79
A8970B2	33-17-02	XDS80
A8970B2	33-17-03	XDS101
A8970B2	33-17-03	XDS119
A8970B2	33-17-03	XDS65
A8970B2	33-17-03	XDS66
A8970B2	33-17-03	XDS67

Raytheon Aircraft

BEECH BONANZA WIRING DIAGRAM MANUAL

PART NUMBER INDEX (CONTINUED)

Part Number	GAMA/ATA Code	Reference Designator
A8970B2	33-17-03	XDS68
A8970B2	33-17-03	XDS69
A8970B2	33-17-03	XDS70
A8970B2	33-17-03	XDS71
A8970B2	33-17-03	XDS72
A8970B2	33-17-03	XDS73
A8970B2	33-17-03	XDS74
A8970B2	33-17-03	XDS77
A8970B2	33-17-03	XDS78
A8970B2	33-17-03	XDS79
A8970B2	33-17-03	XDS80
BW20F(1056)	24-30-04	F32
BZ-3AT	27-50-02	S76
BZ-3AT	32-30-01	S36
BZ-3AT	32-30-01	S36
BZ-3AT	32-30-02	S36
BZ-3AT	32-30-02	S36
CA124G	39-10-40	U1
CA124G	39-10-41	U1
CA3101E10SL3P-F80	33-40-01	J102
CA3101E10SL3P-F80	33-40-02	J103
CA3101E10SL3P-F80	33-40-02	J103
CA3106E10SL-3S-F80	33-40-01	P38A
CA3106E10SL3P-F80	33-40-02	J102
CA3106E10SL3P-F80	33-40-02	J102
CA3106E10SL3S-F80	33-40-01	P100
CA3106E10SL3S-F80	33-40-01	P101
CA3106E10SL3S-F80	33-40-01	P102
CA3106E10SL3S-F80	33-40-01	P103
CA3106E10SL3S-F80	33-40-01	P97
CA3106E10SL3S-F80	33-40-01	P97
CA3106E10SL3S-F80	33-40-01	P98
CA3106E10SL3S-F80	33-40-01	P99
CA3106E10SL3S-F80	33-40-02	P100
CA3106E10SL3S-F80	33-40-02	P101
CA3106E10SL3S-F80	33-40-02	P102
CA3106E10SL3S-F80	33-40-02	P103
CA3106E10SL3S-F80	33-40-02	P38A
CA3106E10SL3S-F80	33-40-02	P97
CA3106E10SL3S-F80	33-40-02	P98
CA3106E10SL3S-F80	33-40-02	P99
CA3106E10SL3S-F80	33-40-02	P100
CA3106E10SL3S-F80	33-40-02	P101
CA3106E10SL3S-F80	33-40-02	P102
CA3106E10SL3S-F80	33-40-02	P103
CA3106E10SL3S-F80	33-40-02	P38A
CA3106E10SL3S-F80	33-40-02	P97
CA3106E10SL3S-F80	33-40-02	P98
CA3106E10SL3S-F80	33-40-02	P99
CA3106E12S3S	77-20-01	P21
CB2330	24-50-01	CB19
CB2330	24-51-01	CB19
CB2330	24-51-02	CB19
CB2330	24-51-02	CB19
CB2330	24-52-01	CB19
CB2330	32-30-01	CB19
CB2330	32-31-01	CB19
CKR06BX104KR	39-10-40	C1

Part Number	GAMA/ATA Code	Reference Designator
CKR05BX103KR	39-10-03	A10A1C3
CKR06BX104KR	39-10-40	C3
CKR06BX104KR	39-10-40	C4
CKR06BX104KR	39-10-40	C5
CKR06BX104KR	39-10-41	C1
CKR06BX104KR	39-10-41	C3
CKR06BX104KR	39-10-41	C4
CKR06BX104KR	39-10-41	C5
CK05BX471K	39-10-40	C6
CSR13G105KM	39-10-03	A10A1C2
CSR13G106KM	39-10-03	A10A1C1
CT2A	25-12-01	M27
C281XDX1031	91-01-01	A19K3
C281XDX1031	91-01-02	A19K3
C5AZ13713A	33-42-01	S28
D160-00-3	27-50-01	B22
D160-00-3	27-50-02	B22
D160-00-3	27-50-02	B22
D165-100-2	33-14-01	DS53B
D165-100-2	33-14-02	DS53B
D165-100-2	33-14-03	DS53B
D165-100-2	33-17-01	DS53B
D165-100-2	33-17-02	DS53B
D165-100-2	33-17-03	DS53B
D165-100-2	33-18-01	DS28B
D165-100-2	33-18-01	DS29B
D165-100-2	33-18-01	DS30B
D165-100-2	33-18-01	DS31B
D165-100-2	33-18-01	DS32B
D165-100-2	33-18-01	DS33B
D165-100-2	33-18-01	DS34B
D165-100-2	33-18-01	DS35B
D165-100-2	33-18-01	DS36B
D165-100-2	33-18-01	DS37B
D165-100-2	33-18-01	DS38B
D165-100-2	33-18-01	DS39B
D165-100-2	33-18-01	DS53B
D165-100-2	33-18-01	DS28B
D165-100-2	33-18-01	DS29B
D165-100-2	33-18-01	DS30B
D165-100-2	33-18-01	DS31B
D165-100-2	33-18-01	DS32B
D165-100-2	33-18-01	DS33B
D165-100-2	33-18-01	DS34B
D165-100-2	33-18-01	DS35B
D165-100-2	33-18-01	DS36B
D165-100-2	33-18-01	DS37B
D165-100-2	33-18-01	DS38B
D165-100-2	33-18-01	DS39B
D165-100-2	33-18-01	DS53B
D426-36	24-30-04	A35SP1
D426-37	24-30-04	A35SP2
D7080A1-24	33-44-01	DS140B
D7080A1-24	33-44-02	DS140B
D7080A1-24	33-44-02	DS140R
D7080A3-24	33-44-01	DS140B
D7080A3-24	33-44-02	DS140B
D7080A3-24	33-44-02	DS140R

Raytheon Aircraft

BEECH BONANZA WIRING DIAGRAM MANUAL

PART NUMBER INDEX (CONTINUED)

Part Number	GAMA/ATA Code	Reference Designator
MHJ-4003	24-30-04	B15
MHJ-4003	24-30-04	B15
MHJ-4003	24-30-04	B15
MHJ-4003	24-30-04	B15
MLA-60-50	24-30-04	R34
MLA-60-50	24-30-04	R34
MLA-60-50	24-30-04	R34
MLA-60-50	24-30-04	R34
MST-105D	27-32-01	S46
MST-205T	33-10-01	S31
MST205T	25-60-01	S139
MS21042L3	33-43-01	GS4C
MS21045L3	33-43-01	GS2C
MS24482-1	77-20-01	RT13
MS24510-15	21-50-01	CB33
MS24510-15	24-52-02	CB17
MS24510-15	24-52-02	CB17
MS24510-15	27-50-02	CB17
MS24510-15	27-50-02	CB17
MS24510-30	24-52-02	CB19
MS24510-30	24-52-02	CB19
MS24510-30	32-30-01	CB19
MS24510-30	32-30-01	CB19
MS24510-30	32-30-02	CB19
MS24510-30	32-30-02	CB19
MS24510-30	32-31-01	CB19
MS24510-30	32-31-02	CB19
MS24659-23D	28-20-03	S53
MS25006-1	27-50-02	S51
MS25008-1	21-50-01	S73B
MS25008-1	21-50-02	S73B
MS25008-1	32-30-01	S39
MS25008-1	32-30-02	S39
MS25008-1	32-30-02	S73B
MS25008-1	32-30-02	S39
MS25008-1	32-30-02	S73B
MS25008-1	32-31-02	S39
MS25008-1	32-31-02	S73B
MS25026-1	21-50-01	S68
MS25026-1	21-50-02	S68
MS25026-1	21-50-03	S68
MS25026-1	21-50-03	S68
MS25026-1	21-50-03	S68
MS25026-1	27-50-01	S50
MS25026-1	27-50-01	S51
MS25026-1	27-50-02	S47
MS25026-1	27-50-02	S50
MS25026-1	27-50-02	S51
MS25026-1	27-50-02	S76
MS25026-1	27-50-02	S47
MS25026-1	27-50-02	S59
MS25026-1	32-30-01	S37
MS25026-1	32-30-01	S39
MS25026-1	32-30-01	S40
MS25026-1	32-30-01	S45
MS25026-1	32-30-01	S37
MS25026-1	32-30-01	S40

Part Number	GAMA/ATA Code	Reference Designator
MS25026-1	32-30-01	S45
MS25026-1	32-30-02	S40
MS25026-1	32-30-02	S45
MS25026-1	32-30-02	S40
MS25026-1	32-30-02	S45
MS25026-1	32-31-01	S36
MS25026-1	32-31-01	S37
MS25026-1	32-31-01	S39
MS25026-1	32-31-01	S40
MS25026-1	32-31-02	S36
MS25026-1	32-31-02	S39
MS25026-1	32-31-02	S40
MS25026-1	32-31-02	S45
MS25026-1	32-60-01	S40
MS25026-1	32-60-01	S45
MS25026-1	32-60-01	S40
MS25026-1	32-60-01	S45
MS25026-1	33-10-01	S16
MS25026-1	33-10-01	S67
MS25026-1	33-10-02	S16
MS25026-1	33-10-02	S67
MS25026-1	33-10-02	S16
MS25026-1	33-10-02	S67
MS25026-1	33-10-02	S67
MS25041-4	36-20-02	XDS6
MS25041-4	36-20-02	XDS6
MS25041-6	36-20-02	XDS5
MS25041-6	36-20-02	XDS5
MS25083-1BA6	27-51-01	BS1
MS25083-1BA6	27-51-02	BS1
MS25125-E3	32-30-01	S38
MS25125-E3	32-30-01	S38
MS25125-E3	32-30-02	S38
MS25125-E3	32-30-02	S38
MS25126-B1	27-50-01	S52
MS25237-327	33-11-01	DS18
MS25237-327	33-11-02	DS18
MS25237-327	33-11-02	DS18
MS25237-327	36-20-02	DS5
MS25237-327	36-20-02	DS6
MS25237-327	36-20-02	DS5
MS25237-327	36-20-02	DS6
MS27212-2-2	24-34-01	TB15
MS27212-2-2	24-34-02	TB15
MS27212-2-2	24-52-01	TB15
MS27212-2-2	24-52-02	TB15
MS27212-2-2	24-52-02	TB15
MS27407-1	21-50-01	S71
MS27407-1	21-50-02	S71
MS27407-1	21-50-03	S71
MS27407-1	21-50-03	S71
MS27407-1	21-50-03	S71
MS27407-1	21-50-03	S71
MS27407-1	21-50-03	S71
MS27408-1M	28-20-03	S11
MS27408-1N	28-20-03	S11
MS27408-1N	28-20-03	S11
MS28034-1	77-20-01	RT14
MS3101E10SL3P	33-40-01	J102

Raytheon Aircraft

BEECH BONANZA WIRING DIAGRAM MANUAL

PART NUMBER INDEX (CONTINUED)

Part Number	GAMA/ATA Code	Reference Designator
MS3101E10SL3P	33-40-01	J103
MS3102A10SL3P	33-40-01	DS12G2
MS3102A10SL3P	33-40-02	DS12G
MS3102A10SL3P	33-40-02	DS12G
MS3106A-10SL-3S	28-20-03	P25
MS3106A/B10SL3S	33-10-01	P60
MS3106A/B10SL3S	33-10-02	P60
MS3106A/B10SL3S	33-10-02	P60
MS3106A/B10SL3S	33-10-02	P60
MS3106A18-1S	24-31-01	P45
MS3106A18-1S	24-33-01	P46
MS3106A18-1S	24-33-02	P46
MS3106A18-1S	24-34-01	P46
MS3106A18-1S	24-34-02	P46
MS3106E10SL-3S	33-40-01	P38A
MS3106E10SL-3S	33-40-01	P97
MS3106E10SL-3S	33-40-01	P98
MS3106E10SL-3S	33-40-01	P99
MS3106E10SL-3S	33-40-02	P38A
MS3106E10SL-3S	33-40-02	P97
MS3106E10SL-3S	33-40-02	P98
MS3106E10SL-3S	33-40-02	P99
MS3106E10SL-3S	33-40-02	P38A
MS3106E10SL-3S	33-40-02	P97
MS3106E10SL-3S	33-40-02	P98
MS3106E10SL-3S	33-40-02	P99
MS3106E10SL-3S	33-40-02	P97
MS3106E10SL-3S	33-40-02	P98
MS3106E10SL-3S	33-40-02	P99
MS3106R20-15S	30-60-01	P41
MS3106R20-15S	30-60-01	P41
MS3108E10SL-3S	73-30-01	P18
MS3108F10SL-3S	73-30-01	P18
MS91586-2	24-30-01	R34
MS91586-2	24-30-01	R34
MS91586-2	24-30-02	R34
MS91586-2	24-30-02	R34
MS91586-2	24-30-03	R34
MS91586-2	24-30-03	R34
MS91586-6	24-30-01	R34
MS91586-6	24-30-01	R34
MS91586-6	24-30-02	R34
MS91586-6	24-30-02	R34
MS91586-6	24-30-03	R34
MS91586-6	24-30-03	R34
MS91586-6	24-30-04	R34
MS91586-6	24-30-04	R34
MS91586-6	24-30-04	R34
MS91586-6	24-30-04	R34
M4007-1.5	34-22-01	S77
M4007-1.5	36-20-02	S77
M4007-1.5	36-20-02	S77
M4008-7	21-50-02	S74
M4008-7	21-50-03	S74
M4008-7	21-50-03	S74
M7078/3-16-3	33-40-01	W10
M7078/3-16-3	33-40-02	W10
M7078/3-16-3	33-40-02	W10
M81714/2-AB1	33-14-03	TB20
M81714/7-AA1	33-13-03	TB16
M81714/7-AA1	33-17-03	TB17

Part Number	GAMA/ATA Code	Reference Designator
M81714/7-AB1	33-12-03	TB18
M81714/7-AB1	33-14-03	TB19
PL-1	33-14-01	XDS53
PL-1	33-14-02	XDS53
PL-1	33-14-03	XDS53
PL-1	33-17-02	XDS53
PL-1	33-17-03	XDS53
PL-1	33-18-01	XDS53
PL-1	33-18-01	XDS53
PS12-11	24-30-01	BT10
PS12-11	24-30-01	BT10
PS12-11	24-30-02	BT10
PS12-11	24-30-02	BT10
PS12-11	24-30-03	BT10
PS12-11	24-30-03	BT10
PS12-11	24-30-04	BT10
PS12-11	24-30-04	BT10
PS12-11	24-30-04	BT10
PS12-11	24-30-04	BT10
PT06E14-15S/SR	73-30-01	P17
P5	23-50-01	LS13
RCR07G102JS	39-10-41	R2
RCR07G102JS	39-10-41	R5
RCR07G103JS	39-10-40	R2
RCR07G103JS	39-10-40	R4
RCR07G103JS	39-10-40	R5
RCR07G103JS	39-10-41	R4
RCR07G302JS	39-10-40	R1
RCR07G302JS	39-10-41	R1
RCR07G471JS	39-10-40	R3
RCR07G471JS	39-10-41	R3
RCR20G202JS	39-10-03	A10A1R19
RCR20G432JS	39-10-20	A19A1R3
RCR20G471GS	39-10-03	A10A1R21
RCR20G511JS	39-10-01	A10A1A1R7
RCR20G511JS	39-10-02	A10A1A1R7
RCR20G511JS	39-10-03	A10A1R7
RCR20G511JS	91-01-02	A19A1F
RCR20G511KS	39-10-01	A10A1A1R7
RCR20G511KS	39-10-02	A10A1A1R7
RCR20G562JS	39-10-01	A10A1A1R3
RCR20G562JS	39-10-02	A10A1A1R3
RCR20G562JS	39-10-03	A10A1R3
RCR20G562JS	91-01-01	A19A2F
RCR20G562JS	91-01-02	A19A2F
RCR20G562KS	39-10-01	A10A1A1R3
RCR20G562KS	39-10-02	A10A1A1R3
RCR32G511JS	91-01-02	A19A1E
RCR42GF510J	39-10-30	A19A2R2
RCR42GF510K	39-10-30	A19A2R2
RCR42G151JS	39-10-01	A10A1A1R6
RCR42G151JS	39-10-02	A10A1A1R6
RCR42G151JS	39-10-03	A10A1R6
RCR42G151KS	39-10-01	A10A1A1R6
RCR42G151KS	39-10-02	A10A1A1R6
RCR42G361JS	39-10-01	A10A1A1R1
RCR42G361JS	39-10-02	A10A1A1R1
RCR42G361JS	39-10-03	A10A1R1

Raytheon Aircraft

BEECH BONANZA WIRING DIAGRAM MANUAL

PART NUMBER INDEX (CONTINUED)

Part Number	GAMA/ATA Code	Reference Designator
RCR42G361JS	91-01-02	A19A2D
RCR42G361KS	39-10-01	A10A1A1R1
RCR42G361KS	39-10-02	A10A1A1R1
RCR42G680JS	33-15-01	A21R1
RCR42G680JS	33-15-01	A21R2
RCR42G680JS	33-15-01	A21R3
RCR42G680JS	33-15-01	A21R4
RCR42G680JS	33-15-02	A21R1
RCR42G680JS	33-15-02	A21R2
RCR42G680JS	33-15-02	A21R3
RCR42G680JS	33-15-02	A21R4
RC07GF302J	39-10-10	A13R4
RC07GF471J	39-10-10	A13R2
RC20GF511J	91-01-01	A19A1F
RC32GF511J	91-01-01	A19A1E
RC42GF361J	91-01-01	A19A2D
RC42GF470K	39-10-30	A19A2R1
RC42GF470K	91-01-01	A19A1D
RC42GF820J	39-10-20	A19A1R1
RC42G151KS	91-01-02	A19A1D
RH5-150	25-60-01	R75
RLR07C1001GS	39-10-03	A10A1R20
RLR07C1002GS	39-10-03	A10A1R18
RLR07C4701GS	39-10-03	A10A1R16
RLR07C7500GR	39-10-41	R8
RNC55H4992FS	39-10-40	R6
RNC55H4992FS	39-10-41	R6
RNC55H5622FS	39-10-40	R7
RNC55H5622FS	39-10-41	R7
RNR55C2321FM	39-10-40	R8
RNR60C5113FR	39-10-03	A10A1R15
RT22CW202	39-10-01	A10A1A1R2
RT22CW202	39-10-02	A10A1A1R2
RT22C2W202	39-10-03	A10A1R2
R102	91-01-01	A19F1
R102	91-01-02	A19F1
R102	91-02-01	A10A1DS1
R102	91-02-02	A10A1DS1
SW442	33-42-01	S28
S6RN1225	74-30-01	E19
S6RN1225	74-30-01	E20
TNR/D11720S	21-50-03	K16
TNR11720	21-50-03	K16
TR70-13	25-60-01	E38
VW1KSPB	33-15-01	R16
VW1KSPB	33-15-01	R17
VW1KSPB	33-15-01	R18
VW1KSPB	33-15-01	R19
VW1KSPB	33-15-02	R16
VW1KSPB	33-15-02	R17
VW1KSPB	33-15-02	R18
VW1KSPB	33-15-02	R19
V3-1	21-50-01	S42
V3-1	21-50-02	S42
V3-1	21-50-03	S42
V3-1	21-50-03	S42
V3-1	21-50-03	S42
V3-1	21-50-03	S42

Part Number	GAMA/ATA Code	Reference Designator
V3-1	32-31-01	S34
V3-1	32-31-02	S34
V3-1	32-60-01	S41
WCD421-ABE02	32-60-02	XDS148
WF2K10R	24-30-01	Y1E
WF2K10R	24-30-02	Y1E
WF2K10R	24-30-03	Y1E
WF2K10R	24-30-04	Y1E
WF2K10R	24-30-04	A35R1
WRML20	33-44-02	DS140L
WRML20L	33-44-02	DS140L
WRML24CCW	33-44-02	DS141H
WRML24CCW	33-44-02	DS141H
WRML24CCW	33-44-02	DS141H
WRML24CCW	33-44-02	DS141P
WRML24CCW	33-44-02	DS141P
WRML24CW	33-44-02	DS140H
WRML24CW	33-44-02	DS140H
WRM10	33-44-02	DS140P
WRM10	33-44-02	DS141P
WRM10	33-44-02	DS140P
WRM10	33-44-02	DS141P
WRM10	33-44-02	DS141P
WRM10	33-44-02	DS141P
WRM10	33-44-02	DS141V
WRM10	33-44-02	DS141V
WRM15	33-44-02	DS140N
WRM15	33-44-02	DS141N
WRM15	33-44-02	DS140N
WRM15	33-44-02	DS141N
WRM15	33-44-02	DS141N
WRM15	33-44-02	DS141U
WRM15	33-44-02	DS141U
WRM1939	33-44-02	DS140M
WRM1939	33-44-02	DS141M
WRM1939	33-44-02	DS140M
WRM1939	33-44-02	DS141M
WRM1939	33-44-02	DS141M
WRM1939	33-44-02	DS141T
WRM1939	33-44-02	DS141T
WRM20L	33-44-02	DS141L
WRM20L	33-44-02	DS141L
WRM20L	33-44-02	DS141L
WRM20L	33-44-02	DS141S
WRM20L	33-44-02	DS141S
WRM30	33-44-02	DS140K
WRM30	33-44-02	DS141K
WRM30	33-44-02	DS140K
WRM30	33-44-02	DS141K
WRM30	33-44-02	DS141K
WRM30	33-44-02	DS141R
WRM30	33-44-02	DS141R
WRM40	33-44-02	DS140J
WRM40	33-44-02	DS141J
WRM40	33-44-02	DS140J
WRM40	33-44-02	DS141J
WRM40	33-44-02	DS141J
WRM40	33-44-02	DS141Q
WRM40	33-44-02	DS141Q

Raytheon Aircraft

BEECH BONANZA WIRING DIAGRAM MANUAL

PART NUMBER INDEX (CONTINUED)

Part Number	GAMA/ATA Code	Reference Designator
002-361013-47	21-50-01	S73A
002-361013-47	21-50-02	S73A
002-361013-47	32-31-02	S73A
002-361013-55	32-30-02	S73A
002-361013-55	32-30-02	S73A
002-361016-7	24-30-01	W22
002-361016-7	24-30-01	W22
002-361016-7	24-30-02	W22
002-361016-7	24-30-02	W22
002-361016-7	24-30-02	W22
002-361016-7	24-30-03	W22
002-361016-7	24-30-03	W22
002-361016-7	24-30-04	W22
002-361016-7	24-30-04	W22
002-361016-7	24-30-04	W22
002-361016-7	24-30-04	W22
002-364037-15	91-01-02	A19
002-364037-3	91-01-01	A19
002-364038-1	39-10-30	A19A2
002-364038-3	91-01-01	A19A1A
002-364038-3	91-01-02	A19A1A
002-364039-1	91-01-01	A19A1B
002-364039-1	91-01-02	A19A1B
002-364040-1	39-10-20	A19A1
002-364040-3	91-01-01	A19A2A
002-364040-3	91-01-02	A19A2A
002-364041	39-10-20	A19A1W1
002-364041	91-01-01	A19A2B
002-364041	91-01-02	A19A2B
002-364042-35	33-15-01	A21
002-364042-35	33-15-02	A21
002-369014-3	24-30-01	W11
002-369014-3	24-30-01	W11
002-369014-3	24-30-02	W11
002-369014-3	24-30-02	W11
002-369014-3	24-30-03	W11
002-369014-3	24-30-03	W11
002-369014-3	24-30-03	W11
002-369014-3	24-30-03	W11
002-369014-3	24-30-03	W11
002-381000-1	28-40-05	R24
002-381000-3	28-40-05	R25
01-0790079-04	33-40-01	PS11
01-0790079-04	33-40-02	PS11
01-0790079-04	33-40-02	PS11
03-06-1011	25-60-01	J132
03-06-2011	25-60-01	P131
0366	27-32-01	R46
1 3/4D48F40	91-01-01	A19R1
1 3/4D48F40	91-01-02	A19R1
1.5KE51AC	33-45-01	CR53
1.5KE51CA	24-30-01	CR20
1.5KE51CA	24-30-01	CR21
1.5KE51CA	24-30-01	CR20
1.5KE51CA	24-30-01	CR21
1.5KE51CA	24-30-02	CR20
1.5KE51CA	24-30-02	CR20
1.5KE51CA	24-30-03	CR20
1.5KE51CA	24-30-03	CR20
1.5KE51CA	24-30-04	CR20
1.5KE51CA	24-30-04	CR20
1.5KE51CA	24-30-04	CR21

Part Number	GAMA/ATA Code	Reference Designator
1.5KE51CA	24-30-04	CR20
1.5KE51CA	24-30-04	CR20
1.5KE51CA	24-33-01	CR19
1.5KE51CA	24-33-01	CR32
1.5KE51CA	24-33-01	CR41
1.5KE51CA	24-33-02	CR19
1.5KE51CA	24-33-02	CR32
1.5KE51CA	24-33-02	CR41
1.5KE51CA	24-34-01	CR19
1.5KE51CA	24-34-01	CR32
1.5KE51CA	24-34-01	CR41
1.5KE51CA	24-34-02	CR19
1.5KE51CA	24-34-02	CR32
1.5KE51CA	24-34-02	CR41
1.5KE51CA	27-50-02	CR38
1.5KE51CA	27-50-02	CR39
1.5KE51CA	27-50-02	CR38
1.5KE51CA	27-50-02	CR39
1.5KE51CA	28-20-03	CR13
1.5KE51CA	32-30-01	CR22
1.5KE51CA	32-30-01	CR23
1.5KE51CA	32-30-01	CR22
1.5KE51CA	32-30-01	CR23
1.5KE51CA	32-30-02	CR22
1.5KE51CA	32-30-02	CR23
1.5KE51CA	32-30-02	CR22
1.5KE51CA	32-30-02	CR23
1.5KE51CA	32-30-02	CR22
1.5KE51CA	32-31-01	CR22
1.5KE51CA	32-31-01	CR23
1.5KE51CA	32-31-02	CR22
1.5KE51CA	32-31-02	CR23
1-205201-6	91-19-02	P54B
1-205202-6	32-30-01	J54B
1-205202-6	32-31-01	J54C
1-205202-6	32-60-01	J54C
1-205202-6	33-10-01	J54B
1-205202-6	91-19-02	J54B
1-350867-0	25-60-01	P130A
1-350868-0	25-60-01	J130A
1-480270-0	24-33-01	P31A
1-480270-0	24-33-02	P31A
1-480270-0	24-34-01	P31A
1-480270-0	24-34-02	P31A
1-480270-0	27-50-02	P53A
1-480270-0	27-50-02	P53A
1-480270-0	28-40-01	P63A
1-480270-0	28-40-01	P64A
1-480270-0	28-40-02	P63A
1-480270-0	28-40-02	P64A
1-480270-0	28-40-03	P63A
1-480270-0	28-40-03	P64A
1-480270-0	32-60-01	P59A
1-480270-0	32-60-01	P59A
1-480270-0	32-60-02	P31A
1-480270-0	33-11-01	P31A
1-480270-0	33-11-02	P31A
1-480270-0	33-11-02	P31A
1-480270-0	33-18-01	P31A

Raytheon Aircraft

BEECH BONANZA WIRING DIAGRAM MANUAL

PART NUMBER INDEX (CONTINUED)

Part Number	GAMA/ATA Code	Reference Designator
1-480270-0	33-18-01	P31A
1-480270-0	91-22-01	P31A
1-480277-0	77-20-01	P22A
1-480283-0	24-33-01	P31B
1-480283-0	24-33-02	P31B
1-480283-0	24-34-01	P31B
1-480283-0	24-34-02	P31B
1-480283-0	32-30-01	P56
1-480283-0	32-30-02	P56
1-480283-0	32-31-01	P56
1-480283-0	32-31-02	P56
1-480283-0	32-60-01	P56
1-480283-0	32-60-02	P31B
1-480283-0	33-11-01	P31B
1-480283-0	33-11-02	P31B
1-480283-0	33-11-02	P31B
1-480283-0	91-22-01	P31B
1-480287-0	27-50-02	P30A
1-480287-0	27-50-02	P30A
1-480287-0	32-30-01	P85A
1-480287-0	32-30-01	P85A
1-480287-0	32-30-02	P85A
1-480287-0	32-30-02	P85A
1-480287-0	32-31-01	P85A
1-480287-0	32-31-02	P85A
1-480287-0	32-60-01	P85A
1-480287-0	32-60-01	P85A
1-480287-0	33-10-01	P51A
1-480287-0	33-10-02	P51A
1-480287-0	33-10-02	P51A
1-480287-0	33-10-02	P51A
1-480287-0	33-12-02	P121A
1-480287-0	33-12-02	P122A
1-480287-0	33-13-02	P122A
1-480287-0	33-14-02	P123A
1-480287-0	33-14-02	P124A
1-480287-0	33-15-01	P30A
1-480287-0	33-15-02	P30A
1-480287-0	33-17-02	P123A
1-480287-0	33-17-02	P124A
1-480287-0	33-45-01	P85A
1-480287-0	33-45-01	P85A
1-480287-0	91-21-01	P85A
1-480287-0	91-21-01	P85A
1-480288-0	27-50-02	J30A
1-480288-0	27-50-02	J30A
1-480288-0	32-30-01	J85A
1-480288-0	32-30-01	J85A
1-480288-0	32-30-02	J85A
1-480288-0	32-30-02	J85A
1-480288-0	32-31-01	J85A
1-480288-0	32-31-02	J85A
1-480288-0	32-60-01	J85A
1-480288-0	32-60-01	J85A
1-480288-0	33-10-01	J51A
1-480288-0	33-10-02	J51A
1-480288-0	33-10-02	J51A
1-480288-0	33-10-02	J51A

Part Number	GAMA/ATA Code	Reference Designator
1-480288-0	33-12-02	J121A
1-480288-0	33-12-02	J122A
1-480288-0	33-13-02	J122A
1-480288-0	33-14-02	J123A
1-480288-0	33-14-02	J124A
1-480288-0	33-15-01	J30A
1-480288-0	33-15-02	J30A
1-480288-0	33-17-02	J123A
1-480288-0	33-17-02	J124A
1-480288-0	33-45-01	J85A
1-480288-0	33-45-01	J85A
1-480288-0	91-21-01	J85A
1-480288-0	91-21-01	J85A
1-480318-0	25-10-01	P73A
1-480318-0	25-10-01	P79A
1-480318-0	25-10-02	P79A
1-480318-0	25-10-03	P73A
1-480318-0	25-10-03	P79A
1-480318-0	27-50-01	P74A
1-480318-0	28-20-01	P49A
1-480318-0	28-20-02	P49A
1-480318-0	28-20-04	P49A
1-480318-0	28-20-05	P49A
1-480318-0	28-20-05	P50A
1-480318-0	33-11-01	P65A
1-480318-0	33-11-02	P65A
1-480318-0	33-11-02	P65A
1-480318-0	33-20-02	P156A
1-480318-0	33-20-02	P157A
1-480318-0	33-20-02	P57A
1-480318-0	33-44-01	P69A
1-480318-0	33-44-01	P71A
1-480318-0	33-44-02	P42A
1-480318-0	33-44-02	P43A
1-480318-0	33-44-02	P71A
1-480318-0	33-44-02	P42A
1-480318-0	33-44-02	P43A
1-480318-0	33-44-02	P71A
1-480318-0	33-44-02	P42A
1-480318-0	33-44-02	P43A
1-480318-0	33-44-02	P69A
1-480318-0	33-44-02	P71A
1-480318-0	33-45-01	P66A
1-480318-0	33-45-01	P66A
1-480319-0	25-10-01	J73A
1-480319-0	25-10-01	J79A
1-480319-0	25-10-02	J79A
1-480319-0	25-10-03	J73A
1-480319-0	25-10-03	J79A
1-480319-0	28-20-01	J49A
1-480319-0	28-20-02	J49A
1-480319-0	28-20-02	J50A
1-480319-0	28-20-02	P50A
1-480319-0	28-20-04	J49A
1-480319-0	28-20-05	J49A
1-480319-0	28-20-05	J50A
1-480319-0	33-11-01	J65A
1-480319-0	33-11-02	J65A

Raytheon Aircraft

BEECH BONANZA WIRING DIAGRAM MANUAL

PART NUMBER INDEX (CONTINUED)

Part Number	GAMA/ATA Code	Reference Designator
1-480319-0	33-11-02	J65A
1-480319-0	33-20-02	J156A
1-480319-0	33-20-02	J157A
1-480319-0	33-20-02	J57A
1-480319-0	33-44-01	J69A
1-480319-0	33-44-01	J71A
1-480319-0	33-44-02	J42A
1-480319-0	33-44-02	J43A
1-480319-0	33-44-02	J71A
1-480319-0	33-44-02	J42A
1-480319-0	33-44-02	J43A
1-480319-0	33-44-02	J71A
1-480319-0	33-44-02	J42A
1-480319-0	33-44-02	J43A
1-480319-0	33-44-02	J69A
1-480319-0	33-44-02	J71A
1-480319-0	33-45-01	J66A
1-480319-0	33-45-01	J66A
1-480340	91-22-01	J31A
1-480340-0	24-33-01	J31A
1-480340-0	24-33-02	J31A
1-480340-0	24-34-01	J31A
1-480340-0	24-34-02	J31A
1-480340-0	27-50-02	J53A
1-480340-0	27-50-02	J53A
1-480340-0	28-40-01	J63A
1-480340-0	28-40-01	J64A
1-480340-0	28-40-02	J63A
1-480340-0	28-40-02	J64A
1-480340-0	28-40-03	J63A
1-480340-0	28-40-03	J64A
1-480340-0	32-60-01	J59A
1-480340-0	32-60-01	J59A
1-480340-0	33-11-01	J31A
1-480340-0	33-11-02	J31A
1-480340-0	33-11-02	J31A
1-480340-0	33-18-01	J31A
1-480340-0	33-18-01	J31A
1-480345-0	24-33-01	J31B
1-480345-0	24-33-02	J31B
1-480345-0	24-34-01	J31B
1-480345-0	24-34-02	J31B
1-480345-0	33-11-01	J31B
1-480345-0	33-11-02	J31B
1-480345-0	33-11-02	J31B
1-480345-0	91-22-01	J31B
1-480349-0	33-20-01	P57A
1-480349-0	33-40-01	P67A
1-480349-0	33-40-02	P67A
1-480349-0	33-40-02	P67A
1-480349-0	33-44-01	P58A
1-480349-0	33-45-01	P77A
1-480349-0	33-45-01	P78A
1-480349-0	33-45-01	P77A
1-480349-0	33-45-01	P78A
1-480350-0	33-44-01	J58A
1-480350-0	33-44-01	P58A
1-480350-0	33-44-01	P71A

Part Number	GAMA/ATA Code	Reference Designator
1-480351-0	33-20-01	J57A
1-480351-0	33-40-01	J67A
1-480351-0	33-40-02	J67A
1-480351-0	33-40-02	J67A
1-480351-0	33-45-01	J77A
1-480351-0	33-45-01	J78A
1-480351-0	33-45-01	J77A
1-480351-0	33-45-01	J78A
1-480424-0	25-11-02	P135A
1-480424-0	27-51-01	P75A
1-480424-0	91-01-01	P75A
1-480426-0	27-51-01	J75A
1-480426-0	91-01-01	J75A
1-480702-1	33-40-01	P38A
1-480702-1	33-40-02	P38A
1-480702-1	33-40-02	P38A
1-480703-0	33-40-01	J38A
1-480703-0	33-40-02	J38A
1-480703-0	33-40-02	J38A
1N1199A	21-50-01	CR37
1N1199A	21-50-02	CR37
1N1199A	21-50-03	CR37
1N1199A	21-50-03	CR37
1N1199A	21-50-03	CR37
1N1199A	21-50-03	CR37
1N1202A	24-33-01	CR33
1N1202A	24-33-02	CR33
1N1202A	24-34-01	CR33
1N1202A	24-34-02	CR33
1N3611	39-10-40	CR4
1N3611	39-10-40	CR5
1N3611	39-10-41	CR4
1N3611	39-10-41	CR5
1N4007	24-30-01	CR24
1N4007	24-30-01	CR25
1N4007	24-30-01	CR24
1N4007	24-30-01	CR25
1N4007	24-30-02	CR24
1N4007	24-30-02	CR25
1N4007	24-30-02	CR24
1N4007	24-30-02	CR25
1N4007	24-30-03	CR24
1N4007	24-30-03	CR25
1N4007	24-30-03	CR24
1N4007	24-30-03	CR25
1N4007	24-30-04	CR24
1N4007	24-30-04	CR25
1N4007	24-30-04	CR24
1N4007	24-30-04	CR25
1N4007	24-30-04	CR24
1N4007	24-30-04	CR25
1N4007	24-30-04	CR24
1N4007	24-30-04	CR25
1N4007	24-33-01	CR31
1N4007	24-33-01	CR34
1N4007	24-33-01	CR40
1N4007	24-33-01	CR42
1N4007	24-33-01	CR43

Raytheon Aircraft

BEECH BONANZA WIRING DIAGRAM MANUAL

PART NUMBER INDEX (CONTINUED)

Part Number	GAMA/ATA Code	Reference Designator
1N4007	24-33-02	CR31
1N4007	24-33-02	CR34
1N4007	24-33-02	CR40
1N4007	24-33-02	CR42
1N4007	24-33-02	CR43
1N4007	24-34-01	CR31
1N4007	24-34-01	CR34
1N4007	24-34-01	CR40
1N4007	24-34-01	CR42
1N4007	24-34-01	CR43
1N4007	24-34-02	CR31
1N4007	24-34-02	CR34
1N4007	24-34-02	CR40
1N4007	24-34-02	CR42
1N4007	24-34-02	CR43
1N4007	24-34-02	CR44
1N4007	24-40-01	CR11
1N4007	25-11-01	CR15
1N4007	25-11-01	CR16
1N4007	25-11-02	CR15
1N4007	25-11-02	CR16
1N4007	25-12-01	CR15
1N4007	25-12-01	CR16
1N4007	25-12-02	CR15
1N4007	25-12-02	CR16
1N4007	25-12-03	CR15
1N4007	25-12-03	CR16
1N4007	32-30-01	A10A1CR18
1N4007	32-30-02	A10A1CR18
1N4007	32-31-01	CR35
1N4007	32-31-02	CR35
1N4007	33-10-02	CR45
1N4007	39-10-01	A10A1A1CR2
1N4007	39-10-02	A10A1A1CR2
1N4007	39-10-03	A10A1CR2
1N4007	39-10-30	A19A2CR1
1N4007	39-10-40	CR1
1N4007	39-10-41	CR1
1N4007	91-01-01	A19A1C
1N4007	91-01-01	A19CR2
1N4007	91-01-02	A19A1C
1N4007	91-01-02	A19CR2
1N4007	91-03-01	A23CR1
1N4007	91-03-01	A23CR2
1N4734	39-10-01	A10A1A1CR1
1N4734	39-10-02	A10A1A1CR1
1N4734	39-10-10	A13CR1
1N4734	39-10-20	A19A1CR1
1N4734	91-01-01	A19A2C
1N4734	91-01-02	A19A2C
1N4734A	39-10-01	A10A1A1CR1
1N4734A	39-10-02	A10A1A1CR1
1N4734A	39-10-03	A10A1CR1
1N4734A	39-10-10	A13CR1
1N4734A	39-10-20	A19A1CR1
1N4734A	39-10-40	CR3
1N4734A	39-10-40	CR6
1N4734A	39-10-41	CR3

Part Number	GAMA/ATA Code	Reference Designator
1N4734A	39-10-41	CR6
1N4742A	39-10-03	A10A1CR27
1N4753	39-10-40	CR2
1N4753	39-10-41	CR2
1N5400	32-31-01	CR36
1N5400	32-31-02	CR36
1N5404	21-50-01	CR27
1N5404	21-50-02	CR27
1N5404	91-03-01	A23CR3
10-357487-242	74-30-02	E13
100-381006-1	21-50-01	S64
100-381006-1	21-50-02	S64
100-381006-1	21-50-03	S64
100-381006-1	21-50-03	S64
100-381006-1	21-50-03	S64
100-381006-1	21-50-03	S64
100-381006-1	32-60-01	S60
100-381006-1	32-60-01	S61
100-381006-1	32-60-01	S62
100-381006-1	32-60-01	S63
100-381006-1	32-60-01	S64
100-381006-1	32-60-01	S65
100-381006-1	32-60-01	S60
100-381006-1	32-60-01	S61
100-381006-1	32-60-01	S62
100-381006-1	32-60-01	S63
100-381006-1	32-60-01	S64
100-381006-1	32-60-01	S65
101-380002-3	21-50-01	S75
101-380002-3	21-50-02	S75
101-380002-3	21-50-03	S75
101-380002-3	21-50-03	S75
101-380002-3	21-50-03	S75
101-380002-3	21-50-03	S75
101-380002-3	21-50-03	S75
101-380002-3	21-50-03	S75
101-384082-3	23-01-01	W30
101-384082-3	25-12-01	W30
101-384082-3	25-12-02	W30
101-384082-3	25-12-03	W30
101-384082-3	27-32-01	W30
101-384082-3	33-11-01	W30
101-384082-3	33-11-02	W30
101-384082-3	33-11-02	W30
102-000007	77-20-01	RT13
102-364031-3	33-44-02	DS141U
102-364031-3	33-44-02	DS141U
102-364031-3	33-44-02	DS141W
102-384040-1	32-60-02	LS10
102-389006-9	21-50-01	E14
102-389006-9	21-50-02	E14
102-389006-9	21-50-03	E14
102-389006-9	21-50-03	E14
102-389006-9	21-50-03	E14
102-389006-9	21-50-03	E14
102-389012-5	73-30-01	MT6
102-389034-1	73-30-01	MT6
114931-1-10	24-33-01	W19
114931-1-10	24-33-02	W19
114931-1-10	24-34-01	W19

Raytheon Aircraft

BEECH BONANZA WIRING DIAGRAM MANUAL

PART NUMBER INDEX (CONTINUED)

Part Number	GAMA/ATA Code	Reference Designator
114931-1-10	24-34-02	W19
114931-1-10	24-50-01	W19
114931-1-10	24-50-02	W19
114931-1-10	24-50-02	W19
114931-1-10	24-51-01	W19
114931-1-10	24-51-02	W19
114931-1-10	24-51-02	W19
114931-1-10	24-52-01	W19
114931-1-10	24-52-02	W19
114931-1-10	24-52-02	W19
114931-1-10	24-52-02	W19
114931-1-10	25-12-01	W19
114931-1-10	25-12-02	W19
114931-1-10	25-12-03	W19
114931-1-10	27-50-01	W19
114931-1-10	27-50-02	W19
114931-1-10	27-50-02	W19
114931-1-10	27-51-01	W19
114931-1-10	27-51-02	W19
114931-1-10	28-20-01	W19
114931-1-10	28-20-02	W19
114931-1-10	28-20-03	W19
114931-1-10	28-20-03	W19
114931-1-10	28-20-03	W19
114931-1-10	28-20-04	W19
114931-1-10	28-20-05	W19
114931-1-10	32-31-02	W19
114931-1-10	33-11-02	W19
114931-1-10	33-11-02	W19
114931-1-10	73-30-01	W19
114931-1-10	74-30-02	W19
114931-1-12	24-50-01	W13
114931-1-12	24-50-02	W13
114931-1-12	24-50-02	W13
114931-1-12	27-31-01	W13
114931-1-12	27-31-02	W13
114931-1-12	27-31-02	W13
114931-1-12	28-40-01	W13
114931-1-12	28-40-02	W13
114931-1-12	28-40-03	W13
114931-1-12	32-31-02	W13
114931-1-12	33-10-02	W13
114931-1-12	33-10-02	W13
114931-1-12	33-10-02	W13
114931-1-12	33-11-01	W13
114931-1-12	33-15-01	W13
114931-1-12	33-20-01	W13
114931-1-12	33-20-02	W13
114931-1-12	36-20-02	W13
114931-1-12	36-20-02	W13
114931-1-2	24-34-01	W28
114931-1-2	24-34-02	W28
114931-1-2	24-50-01	W14
114931-1-2	24-50-02	W14
114931-1-2	24-50-02	W14
114931-1-2	24-51-01	W14
114931-1-2	24-51-02	W14
114931-1-2	24-51-02	W14
114931-1-2	24-52-01	W14
114931-1-2	24-52-01	W28

Part Number	GAMA/ATA Code	Reference Designator
114931-1-2	24-52-02	W14
114931-1-2	24-52-02	W28
114931-1-2	24-52-02	W14
114931-1-2	24-52-02	W28
114931-1-3	24-33-01	W17
114931-1-3	24-33-02	W17
114931-1-3	24-34-01	W17
114931-1-3	24-34-02	W17
114931-1-3	24-51-01	W17
114931-1-3	24-51-02	W17
114931-1-3	24-51-02	W17
114931-1-3	24-52-01	W17
114931-1-4	24-33-01	W16
114931-1-4	24-33-01	W27
114931-1-4	24-33-02	W16
114931-1-4	24-33-02	W27
114931-1-4	24-34-01	W16
114931-1-4	24-51-01	W16
114931-1-4	24-51-01	W27
114931-1-4	24-51-02	W16
114931-1-4	24-51-02	W27
114931-1-4	24-51-02	W16
114931-1-4	24-51-02	W27
114931-1-4	24-51-02	W16
114931-1-4	24-51-02	W27
114931-1-6	24-50-01	W12
114931-1-6	24-50-02	W12
114931-1-6	24-50-02	W12
114931-1-6	24-51-01	W12
114931-1-6	24-51-02	W12
114931-1-6	24-51-02	W12
114931-1-6	24-52-01	W12
114931-1-6	24-52-02	W12
114931-1-6	24-52-02	W12
114931-1-6	30-30-01	W12
114931-1-6	30-30-02	W12
114931-1-6	30-60-01	W12
114931-1-6	30-60-01	W12
114931-1-6	33-11-01	W12
114931-1-6	33-11-02	W12
114931-1-6	33-11-02	W12
114931-1-6	33-40-01	W12
114931-1-6	33-40-02	W12
114931-1-6	33-40-02	W12
114931-1-6	33-43-01	W12
114931-1-6	33-44-01	W12
114931-1-6	33-44-02	W12
114931-1-6	33-44-02	W12
114931-1-6	33-44-02	W12
114931-1-6	33-44-02	W12
114931-1-6	33-45-01	W12
114931-1-6	33-45-01	W12
114931-1-6	33-46-01	W12
114931-1-7	24-51-01	W18
114931-1-7	24-51-02	W18
114931-1-7	24-51-02	W18
114931-1-7	24-52-01	W18
114931-1-7	24-52-02	W18
114931-1-7	24-52-02	W18
114931-10	32-30-01	W19
114931-10	32-30-02	W19

Raytheon Aircraft

BEECH BONANZA WIRING DIAGRAM MANUAL

PART NUMBER INDEX (CONTINUED)

Part Number	GAMA/ATA Code	Reference Designator
114931-10	32-30-02	W19
114931-12	32-30-01	W13
114931-12	32-30-02	W13
114931-12	32-30-02	W13
114931-12	32-60-01	W13
114931-12	32-60-01	W13
114931-12	33-15-02	W13
121P60501R5V1	24-30-01	C11
121P60501R5V1	24-30-01	C11
1296-00-1	28-20-01	B11
1296-00-1	28-20-02	B11
1296-00-1	28-20-04	B11
1296-00-1	28-20-05	B11
1297-00-1	28-20-02	B12
1297-00-1	28-20-05	B12
131270-3	21-50-03	GS1
131270-3	21-50-03	GS1
131270-3	21-50-03	GS1
131270-3	24-30-01	GS2
131270-3	24-30-01	GS2
131270-3	24-30-01	GS3
131270-3	24-30-02	GS3
131270-3	24-30-02	GS3
131270-3	24-30-03	GS3
131270-3	24-30-03	GS3
131270-3	24-30-04	GS3
131270-3	24-30-04	GS3
131270-3	24-30-04	GS3
131270-3	24-30-04	GS3
131270-3	24-30-04	GS3
131270-3	24-33-01	GS2
131270-3	24-33-02	GS2
131270-3	24-34-01	GS2
131270-3	24-34-02	GS2
131270-3	27-50-02	GS1
131270-3	27-50-02	GS1
131270-3	28-20-03	GS5
131270-3	28-20-03	GS5
131270-3	28-20-04	GS5
131270-3	28-20-05	GS5
131270-3	30-60-01	GS2
131270-3	30-60-01	GS2
131270-3	32-30-01	GS1
131270-3	32-30-02	GS1
131270-3	32-31-01	GS1
131270-3	32-31-02	GS1
131270-3	32-31-02	GS3
131270-3	32-60-01	GS1
131270-3	32-60-01	GS3
131270-3	32-60-01	GS5
131270-3	32-60-01	GS3
131270-3	32-60-01	GS5
131270-3	33-11-02	GS5
131270-3	33-11-02	GS5
131270-3	33-15-01	GS1
131270-3	33-15-01	GS5
131270-3	33-15-02	GS5
131270-3	33-43-01	GS2A
131270-3	33-44-02	GS1

Part Number	GAMA/ATA Code	Reference Designator
131270-3	33-44-02	GS1
131270-3	33-44-02	GS1
131270-3	77-20-01	GS3
131270-3	91-02-01	A10A1GS1
131270-3	91-02-02	A10A1GS1
131270-3S	91-02-03	A10GS1
132325 10SL-3S	34-20-01	P35
132325 20-15S	30-60-01	P41
132325 20-15S	30-60-01	P41
132371B1001EBC	39-10-03	A10A1R20
132371B1001EBC	39-10-41	R2
132371B1002EBC	39-10-03	A10A1R18
132371B1002EBC	39-10-40	R2
132371B1002EBC	39-10-40	R4
132371B1002EBC	39-10-40	R5
132371B1002EBC	39-10-41	R4
132371B3001EBC	39-10-10	A13R4
132371B3001EBC	39-10-40	R1
132371B3001EBC	39-10-41	R1
132371B4700EBC	39-10-10	A13R2
132371B4700EBC	39-10-40	R3
132371B4700EBC	39-10-41	R3
132371B4701EBC	39-10-03	A10A1R16
132371B7500EBC	39-10-41	R8
132371C2001EBC	39-10-03	A10A1R19
132371C4301EBC	39-10-20	A19A1R3
132371C4700EBC	39-10-03	A10A1R21
132371C5100EBC	39-10-01	A10A1A1R7
132371C5100EBC	39-10-02	A10A1A1R7
132371C5100EBC	39-10-03	A10A1R7
132371C5100EBC	91-01-01	A19A1F
132371C5100EBC	91-01-02	A19A1F
132371C5601EBC	39-10-01	A10A1A1R3
132371C5601EBC	39-10-02	A10A1A1R3
132371C5601EBC	39-10-03	A10A1R3
132371C5601EBC	91-01-01	A19A2F
132371C5601EBC	91-01-02	A19A2F
132371D5100EBC	91-01-02	A19A1E
132371E1500EFA	39-10-01	A10A1A1R6
132371E1500EFA	39-10-02	A10A1A1R6
132371E1500EFA	39-10-03	A10A1R6
132371E3600EFA	39-10-01	A10A1A1R1
132371E3600EFA	39-10-03	A10A1R1
132371E3600EFA	91-01-02	A19A2D
132371E68R0EFA	33-15-01	A21R1
132371E68R0EFA	33-15-01	A21R2
132371E68R0EFA	33-15-01	A21R3
132371E68R0EFA	33-15-01	A21R4
132371E68R0EFA	33-15-02	A21R1
132371E68R0EFA	33-15-02	A21R2
132371E68R0EFA	33-15-02	A21R3
132371E68R0EFA	33-15-02	A21R4
132373D4992DBD	39-10-40	R6
132373D4992DBD	39-10-41	R6
132373D5622DBD	39-10-40	R7
132373D5622DBD	39-10-41	R7
132373G5113DBB	39-10-03	A10A1R15
132389C103EHM	39-10-03	A10A1C3

Raytheon Aircraft

BEECH BONANZA WIRING DIAGRAM MANUAL

PART NUMBER INDEX (CONTINUED)

Part Number	GAMA/ATA Code	Reference Designator
132389D104EHM	39-10-40	C1
132389D104EHM	39-10-40	C3
132389D104EHM	39-10-40	C4
132389D104EHM	39-10-40	C5
132389D104EHM	39-10-41	C1
132389D104EHM	39-10-41	C3
132389D104EHM	39-10-41	C4
132389D104EHM	39-10-41	C5
132391A1R000FNU	39-10-03	A10A1C2
132391C10R00FNU	39-10-03	A10A1C1
132391D47R00FMU	39-10-40	C2
132391D47R00FMU	39-10-41	C2
132404-11	33-15-01	A21Q1C
132404-11	33-15-01	A21Q2D
132404-11	33-15-01	A21Q3D
132404-11	33-15-01	A21Q4D
132404-11	33-15-02	A21Q1
132404-11	33-15-02	A21Q2
132404-11	33-15-02	A21Q3
132404-11	33-15-02	A21Q4
132404-15	39-10-10	A13Q1
132404-15	39-10-40	Q1
132404-15	39-10-41	Q1
132404-21	39-10-03	A10A1Q2
132404-26	39-10-03	A10A1Q1
132404-42	33-15-01	A21Q1B
132404-42	33-15-01	A21Q2B
132404-42	33-15-01	A21Q3B
132404-42	33-15-01	A21Q4B
132408-10	24-33-01	CR33
132408-10	24-33-02	CR33
132408-10	24-34-01	CR33
132408-10	24-34-02	CR33
132408-18	39-10-40	CR4
132408-18	39-10-40	CR5
132408-18	39-10-41	CR4
132408-18	39-10-41	CR5
132408-22	24-30-01	CR24
132408-22	24-30-01	CR25
132408-22	24-30-01	CR24
132408-22	24-30-01	CR25
132408-22	24-30-02	CR24
132408-22	24-30-02	CR25
132408-22	24-30-02	CR24
132408-22	24-30-02	CR25
132408-22	24-30-03	CR24
132408-22	24-30-03	CR25
132408-22	24-30-03	CR24
132408-22	24-30-03	CR25
132408-22	24-30-04	CR24
132408-22	24-30-04	CR25
132408-22	24-30-04	CR24
132408-22	24-30-04	CR25
132408-22	24-30-04	CR24
132408-22	24-30-04	CR25
132408-22	24-30-04	CR24
132408-22	24-30-04	CR25
132408-22	24-33-01	CR31

Part Number	GAMA/ATA Code	Reference Designator
132408-22	24-33-01	CR34
132408-22	24-33-01	CR40
132408-22	24-33-01	CR42
132408-22	24-33-01	CR43
132408-22	24-33-02	CR31
132408-22	24-33-02	CR34
132408-22	24-33-02	CR40
132408-22	24-33-02	CR42
132408-22	24-33-02	CR43
132408-22	24-34-01	CR31
132408-22	24-34-01	CR34
132408-22	24-34-01	CR40
132408-22	24-34-01	CR42
132408-22	24-34-01	CR43
132408-22	24-34-02	CR31
132408-22	24-34-02	CR34
132408-22	24-34-02	CR40
132408-22	24-34-02	CR42
132408-22	24-34-02	CR43
132408-22	24-34-02	CR44
132408-22	24-40-01	CR11
132408-22	25-11-01	CR15
132408-22	25-11-01	CR16
132408-22	25-11-02	CR15
132408-22	25-11-02	CR16
132408-22	25-12-01	CR15
132408-22	25-12-01	CR16
132408-22	25-12-02	CR15
132408-22	25-12-02	CR16
132408-22	25-12-03	CR15
132408-22	25-12-03	CR16
132408-22	32-30-01	A10A1CR18
132408-22	32-30-02	A10A1CR18
132408-22	32-31-01	CR35
132408-22	32-31-02	CR35
132408-22	33-10-02	CR45
132408-22	39-10-01	A10A1A1CR2
132408-22	39-10-02	A10A1A1CR2
132408-22	39-10-03	A10A1CR2
132408-22	39-10-30	A19A2CR1
132408-22	39-10-40	CR1
132408-22	39-10-41	CR1
132408-22	91-01-01	A19A1C
132408-22	91-01-01	A19CR2
132408-22	91-01-02	A19A1C
132408-22	91-01-02	A19CR2
132408-22	91-03-01	A23CR1
132408-22	91-03-01	A23CR2
132408-9	21-50-01	CR37
132408-9	21-50-02	CR37
132408-9	21-50-03	CR37
132408-9	21-50-03	CR37
132408-9	21-50-03	CR37
132408-9	21-50-03	CR37
132408-9	21-50-03	CR37
132409-31	39-10-01	A10A1A1CR1
132409-31	39-10-02	A10A1A1CR1
132409-31	39-10-03	A10A1CR1
132409-31	39-10-10	A13CR1

Raytheon Aircraft

BEECH BONANZA WIRING DIAGRAM MANUAL

PART NUMBER INDEX (CONTINUED)

Part Number	GAMA/ATA Code	Reference Designator
132409-31	39-10-20	A19A1CR1
132409-31	39-10-40	CR3
132409-31	39-10-40	CR6
132409-31	39-10-41	CR3
132409-31	39-10-41	CR6
132409-31	91-01-01	A19A2C
132409-31	91-01-02	A19A2C
132409-37	39-10-03	A10A1CR27
132409-47	39-10-40	CR2
132409-47	39-10-41	CR2
1495	33-11-01	DS17
1495	33-11-02	DS17
1495	33-11-02	DS17
150D476X9035S2	39-10-40	C2
150D476X9035S2	39-10-41	C2
151-10	27-31-01	S43
151-10	27-31-02	S43
151-10	27-31-02	S43
162D476X9004DD2	39-10-40	C7
162D476X9004DD2	39-10-41	C7
169-380021-11	27-31-01	LS12
169-380021-11	27-31-02	LS12
169-380021-11	91-02-01	A10A1LS2
169-380021-11	91-02-02	A10A1LS2
169-380021-9	91-01-01	A19LS11
169-380021-9	91-01-02	A19LS11
169-380021-9	91-02-01	A10A1LS1
169-380021-9	91-02-02	A10A1LS1
169-380096-5	21-52-01	B19
1717	91-02-01	A10A1R14
1717	91-02-02	A10A1R14
173D336X9006W	39-10-40	C8
173D336X9006W	39-10-41	C8
1819	33-14-01	DS53A
1819	33-14-02	DS53A
1819	33-14-03	DS53A
1819	33-17-01	DS53A
1819	33-17-02	DS53A
1819	33-17-03	DS53A
1819	33-18-01	DS53A
1819	33-18-01	DS53A
1864	33-20-01	DS104
1864	33-20-01	DS105
1864	33-20-02	DS104
1864	33-20-02	DS105
1864	33-42-01	DS42C
1864	33-42-01	DS43C
2B7-34	28-20-03	B13
2B7-34	28-20-03	B13
2B7-34	28-20-03	B13
2N3055	33-15-01	A21Q1A
2N3055	33-15-01	A21Q2A
2N3055	33-15-01	A21Q3A
2N3055	33-15-01	A21Q4A
2N3055H	33-15-01	A21Q1C
2N3055H	33-15-01	A21Q2C
2N3055H	33-15-01	A21Q3C
2N3055H	33-15-01	A21Q4C

Part Number	GAMA/ATA Code	Reference Designator
2N3055H	33-15-02	A21Q1
2N3055H	33-15-02	A21Q2
2N3055H	33-15-02	A21Q3
2N3055H	33-15-02	A21Q4
2N4036	39-10-10	A13Q1
2N4036	39-10-40	Q1
2N4036	39-10-41	Q1
2N5195	39-10-03	A10A1Q2
2N5681	39-10-03	A10A1Q1
200333-1	23-01-01	P80D
200333-1	24-30-01	P80D
200333-1	24-30-01	P80D
200333-1	24-30-02	P80D
200333-1	24-30-02	P80D
200333-1	24-30-03	P80D
200333-1	24-30-03	P80D
200333-1	24-30-04	P80D
200333-1	24-30-04	P80D
200333-1	24-30-04	P80D
200333-1	24-30-04	P80D
200333-1	24-31-01	P80D
200333-1	24-33-01	P80D
200333-1	24-33-02	P80D
200333-1	24-34-01	P80D
200333-1	24-34-02	P80D
200333-1	25-10-01	P80D
200333-1	25-10-02	P80D
200333-1	25-10-03	P80D
200333-1	25-11-01	P80D
200333-1	25-11-02	P80D
200333-1	25-12-01	P80D
200333-1	25-12-02	P80D
200333-1	25-12-03	P80D
200333-1	27-32-01	P80D
200333-1	27-50-01	P80D
200333-1	27-51-01	P80D
200333-1	27-51-02	P80D
200333-1	28-20-01	P80D
200333-1	28-20-02	P80D
200333-1	28-40-01	P80D
200333-1	28-40-02	P80D
200333-1	28-40-03	P80D
200333-1	28-40-04	P80D
200333-1	28-40-05	P80D
200333-1	32-31-01	P80D
200333-1	32-31-02	P80D
200333-1	32-60-02	P80D
200333-1	33-10-01	P80D
200333-1	33-10-02	P80D
200333-1	33-10-02	P80D
200333-1	33-11-01	P80D
200333-1	33-11-02	P80D
200333-1	33-11-02	P80D
200333-1	33-12-01	P80D
200333-1	33-12-02	P80D
200333-1	33-12-03	P80D
200333-1	33-14-01	P80D

Raytheon Aircraft

BEECH BONANZA WIRING DIAGRAM MANUAL

PART NUMBER INDEX (CONTINUED)

Part Number	GAMA/ATA Code	Reference Designator
200333-1	33-14-02	P80D
200333-1	33-14-03	P80D
200333-1	33-15-01	P80D
200333-1	33-15-02	P80D
200333-1	33-16-01	P80D
200333-1	33-18-01	P80D
200333-1	33-18-01	P80D
200333-1	33-20-02	P80D
200333-1	34-20-01	P80D
200333-1	36-20-02	P80D
200333-1	36-20-02	P80D
200333-1	73-30-01	P80D
200333-1	74-30-01	P80D
200333-1	74-30-02	P80D
200333-1	77-20-01	P80D
200333-1	91-01-01	P80D
200333-1	91-01-02	P80D
200333-1	91-02-01	P80D
200333-1	91-02-02	P80D
200333-1	91-15-01	P80E
200333-1	91-15-02	P80E
200838-3	23-01-01	P80A
200838-3	24-30-01	P80A
200838-3	24-30-01	P80A
200838-3	24-30-02	P80A
200838-3	24-30-02	P80A
200838-3	24-30-03	P80A
200838-3	24-30-03	P80A
200838-3	24-30-04	P80A
200838-3	24-30-04	P80A
200838-3	24-30-04	P80A
200838-3	24-30-04	P80A
200838-3	24-31-01	P80A
200838-3	24-33-01	P80A
200838-3	24-33-02	P80A
200838-3	24-34-01	P80A
200838-3	24-34-02	P80A
200838-3	25-10-01	P80A
200838-3	25-10-02	P80A
200838-3	25-10-03	P80A
200838-3	25-11-01	P80A
200838-3	25-11-02	P80A
200838-3	25-12-01	P80A
200838-3	25-12-02	P80A
200838-3	25-12-03	P80A
200838-3	27-32-01	P80A
200838-3	27-50-01	P80A
200838-3	27-51-01	P80A
200838-3	27-51-02	P80A
200838-3	28-20-01	P80A
200838-3	28-20-02	P80A
200838-3	28-40-01	P80A
200838-3	28-40-02	P80A
200838-3	28-40-03	P80A
200838-3	28-40-04	P80A
200838-3	28-40-05	P80A
200838-3	32-31-01	P80A
200838-3	32-31-02	P80A

Part Number	GAMA/ATA Code	Reference Designator
200838-3	32-60-02	P80A
200838-3	33-10-01	P80A
200838-3	33-10-02	P80A
200838-3	33-10-02	P80A
200838-3	33-10-02	P80A
200838-3	33-11-01	P80A
200838-3	33-11-02	P80A
200838-3	33-11-02	P80A
200838-3	33-12-01	P80A
200838-3	33-12-02	P80A
200838-3	33-12-03	P80A
200838-3	33-14-01	P80A
200838-3	33-14-02	P80A
200838-3	33-14-03	P80A
200838-3	33-15-01	P80A
200838-3	33-15-02	P80A
200838-3	33-16-01	P80A
200838-3	33-18-01	P80A
200838-3	33-18-01	P80A
200838-3	33-20-02	P80A
200838-3	34-20-01	P80A
200838-3	36-20-02	P80A
200838-3	36-20-02	P80A
200838-3	73-30-01	P80A
200838-3	74-30-01	P80A
200838-3	74-30-02	P80A
200838-3	77-20-01	P80A
200838-3	91-01-01	P80A
200838-3	91-01-02	P80A
200838-3	91-02-01	P80A
200838-3	91-02-02	P80A
200838-3	91-15-01	P80A
200838-3	91-15-02	P80A
2010B	91-01-01	A19A1G
2010B	91-01-01	A19A2G
2010B	91-01-02	A19A1G
2010B	91-01-02	A19A2G
201224-1	23-01-01	P80B
201224-1	24-30-01	P80B
201224-1	24-30-01	P80B
201224-1	24-30-02	P80B
201224-1	24-30-02	P80B
201224-1	24-30-03	P80B
201224-1	24-30-03	P80B
201224-1	24-30-04	P80B
201224-1	24-30-04	P80B
201224-1	24-30-04	P80B
201224-1	24-30-04	P80B
201224-1	24-30-04	P80B
201224-1	24-30-04	P80B
201224-1	24-30-04	P80B
201224-1	24-31-01	P80B
201224-1	24-33-01	P80B
201224-1	24-33-02	P80B
201224-1	24-34-01	P80B
201224-1	24-34-02	P80B
201224-1	25-10-01	P80B
201224-1	25-10-02	P80B
201224-1	25-10-03	P80B
201224-1	25-11-01	P80B
201224-1	25-11-02	P80B

Raytheon Aircraft

BEECH BONANZA WIRING DIAGRAM MANUAL

PART NUMBER INDEX (CONTINUED)

Part Number	GAMA/ATA Code	Reference Designator
201328-1	91-02-02	P80C
201328-1	91-15-01	P80D
201328-1	91-15-02	P80D
202055	33-40-01	DS12F2
202055	33-40-02	DS12F
202055	33-40-02	DS12F
202065	33-40-01	DS12B2
202065	33-40-02	DS12B
202065	33-40-02	DS12B
202323	33-40-01	DS12E2
202323	33-40-02	DS12E
202323	33-40-02	DS12E
202331	33-40-01	DS12D2
202331	33-40-02	DS12D
202331	33-40-02	DS12D
2023382	33-40-01	DS12C2
203382	33-40-02	DS12C
203382	33-40-02	DS12C
203618-1	23-01-01	P80E
203618-1	24-30-01	P80E
203618-1	24-30-01	P80E
203618-1	24-30-02	P80E
203618-1	24-30-02	P80E
203618-1	24-30-03	P80E
203618-1	24-30-03	P80E
203618-1	24-30-04	P80E
203618-1	24-30-04	P80E
203618-1	24-30-04	P80E
203618-1	24-30-04	P80E
203618-1	24-30-04	P80E
203618-1	24-31-01	P80E
203618-1	24-33-01	P80E
203618-1	24-33-02	P80E
203618-1	24-34-01	P80E
203618-1	24-34-02	P80E
203618-1	25-10-01	P80E
203618-1	25-10-02	P80E
203618-1	25-10-03	P80E
203618-1	25-11-01	P80E
203618-1	25-11-02	P80E
203618-1	25-12-01	P80E
203618-1	25-12-02	P80E
203618-1	25-12-03	P80E
203618-1	27-32-01	P80E
203618-1	27-50-01	P80E
203618-1	27-51-01	P80E
203618-1	27-51-02	P80E
203618-1	28-20-01	P80E
203618-1	28-20-02	P80E
203618-1	28-40-01	P80E
203618-1	28-40-02	P80E
203618-1	28-40-03	P80E
203618-1	28-40-04	P80E
203618-1	28-40-05	P80E
203618-1	32-31-01	P80E
203618-1	32-31-02	P80E
203618-1	32-60-02	P80E
203618-1	33-10-01	P80E
203618-1	33-10-02	P80E

Part Number	GAMA/ATA Code	Reference Designator
203618-1	33-10-02	P80E
203618-1	33-10-02	P80E
203618-1	33-11-01	P80E
203618-1	33-11-02	P80E
203618-1	33-11-02	P80E
203618-1	33-12-01	P80E
203618-1	33-12-02	P80E
203618-1	33-12-03	P80E
203618-1	33-14-01	P80E
203618-1	33-14-02	P80E
203618-1	33-14-03	P80E
203618-1	33-15-01	P80E
203618-1	33-15-02	P80E
203618-1	33-16-01	P80E
203618-1	33-18-01	P80E
203618-1	33-18-01	P80E
203618-1	33-20-02	P80E
203618-1	34-20-01	P80E
203618-1	36-20-02	P80E
203618-1	36-20-02	P80E
203618-1	73-30-01	P80E
203618-1	74-30-01	P80E
203618-1	74-30-02	P80E
203618-1	77-20-01	P80E
203618-1	91-01-01	P80E
203618-1	91-01-02	P80E
203618-1	91-02-01	P80E
203618-1	91-02-02	P80E
203669-6	33-12-01	TB11B
203669-6	33-12-01	TB12B
203669-6	33-13-01	TB12B
203669-6	33-14-01	TB13B
203669-6	33-14-01	TB14B
203669-6	33-17-01	TB13B
203669-6	33-17-01	TB14B
204228-2	33-12-01	TB11A
204228-2	33-12-01	TB12A
204228-2	33-13-01	TB12A
204228-2	33-14-01	TB13A
204228-2	33-14-01	TB14A
204228-2	33-17-01	TB13A
204228-2	33-17-01	TB14A
204814-1	23-01-01	J80
204814-1	24-30-01	J80
204814-1	24-30-01	J80
204814-1	24-30-02	J80
204814-1	24-30-02	J80
204814-1	24-30-03	J80
204814-1	24-30-03	J80
204814-1	24-30-04	J80
204814-1	24-30-04	J80
204814-1	24-31-01	J80
204814-1	25-10-01	J80
204814-1	25-10-02	J80
204814-1	25-10-03	J80
204814-1	25-11-01	J80
204814-1	25-11-02	J80
204814-1	25-12-01	J80

Raytheon Aircraft

BEECH BONANZA WIRING DIAGRAM MANUAL

PART NUMBER INDEX (CONTINUED)

Part Number	GAMA/ATA Code	Reference Designator
204814-1	25-12-02	J80
204814-1	25-12-03	J80
204814-1	27-32-01	J80
204814-1	27-50-01	J80
204814-1	27-51-01	J80
204814-1	27-51-02	J80
204814-1	28-20-01	J80
204814-1	28-20-02	J80
204814-1	28-40-01	J80
204814-1	28-40-02	J80
204814-1	28-40-03	J80
204814-1	28-40-04	J80
204814-1	28-40-05	J80
204814-1	32-31-01	J80
204814-1	32-31-02	J80
204814-1	32-60-02	J80
204814-1	33-10-01	J80
204814-1	33-10-02	J80
204814-1	33-10-02	J80
204814-1	33-10-02	J80
204814-1	33-11-01	J80
204814-1	33-11-02	J80
204814-1	33-11-02	J80
204814-1	33-12-01	J80
204814-1	33-12-02	J80
204814-1	33-12-03	J80
204814-1	33-14-01	J80
204814-1	33-14-02	J80
204814-1	33-14-03	J80
204814-1	33-15-01	J80
204814-1	33-15-02	J80
204814-1	33-16-01	J80
204814-1	33-18-01	J80
204814-1	33-18-01	J80
204814-1	33-20-02	J80
204814-1	34-20-01	J80
204814-1	36-20-02	J80
204814-1	36-20-02	J80
204814-1	73-30-01	J80
204814-1	74-30-01	J80
204814-1	74-30-02	J80
204814-1	77-20-01	J80
204814-1	91-01-01	J80
204814-1	91-01-02	J80
204814-1	91-02-01	J80
204814-1	91-02-02	J80
204814-1	91-15-01	J80
204814-1	91-15-02	J80
205-208	39-10-20	A19A1R2
205-208	91-01-01	A19A2E
205-208	91-01-02	A19A2E
205089-1	32-30-01	P54B
205089-1	32-31-01	P54B
205089-1	32-60-01	P54B
205089-1	33-10-01	P54B
205089-1	91-01-01	J54B
205089-1	91-19-01	J54B
205090-1	91-01-01	P54B

Part Number	GAMA/ATA Code	Reference Designator
205090-1	91-19-01	P54B
205839-3	32-30-01	P54A
205839-3	32-31-01	P54A
205839-3	32-60-01	P54A
205839-3	33-10-01	P54A
205839-3	91-01-01	P54A
205839-3	91-19-01	P54A
205839-3	91-19-02	P54A
205840-3	91-19-02	J54A
206036-3	21-50-01	J11A
206036-3	21-50-02	J11A
206036-3	21-50-03	J11A
206036-3	21-50-03	J11A
206036-3	21-50-03	J11A
206036-3	21-50-03	J11A
206036-3	21-50-03	J11A
206036-3	27-31-02	J10A
206036-3	27-31-02	J10A
206036-3	27-50-01	P10A
206036-3	27-50-02	J44A
206036-3	27-50-02	J44A
206036-3	27-51-01	J10A
206036-3	27-51-02	J44A
206036-3	28-40-01	J11A
206036-3	28-40-02	J10A
206036-3	28-40-02	J11A
206036-3	28-40-03	J10A
206036-3	28-40-03	J11A
206036-3	28-40-04	J10A
206036-3	28-40-04	J11A
206036-3	28-40-05	J10A
206036-3	28-40-05	J11A
206036-3	30-30-02	J10A
206036-3	32-30-01	J56
206036-3	32-30-02	J56
206036-3	32-31-01	J56
206036-3	32-31-02	J56
206036-3	32-60-01	J10A
206036-3	32-60-01	J11A
206036-3	32-60-01	J56
206036-3	32-60-01	J10A
206036-3	32-60-01	J11A
206036-3	32-60-01	J10A
206036-3	32-60-01	J11A
206036-3	33-45-01	J10A
206036-3	33-45-01	J11A
206036-3	33-45-01	J10A
206036-3	33-45-01	J11A
206036-3	91-12-01	J10A
206036-3	91-12-02	J10A
206036-3	91-12-02	J10A
206036-3	91-13-01	J11A
206037-1	21-50-01	P11A
206037-1	21-50-02	P11A
206037-1	21-50-03	P11A
206037-1	21-50-03	P11A
206037-1	21-50-03	P11A
206037-1	21-50-03	P11A
206037-1	27-31-02	P10A
206037-1	27-31-02	P10A
206037-1	27-50-01	J10A

Raytheon Aircraft

BEECH BONANZA WIRING DIAGRAM MANUAL

PART NUMBER INDEX (CONTINUED)

Part Number	GAMA/ATA Code	Reference Designator
206037-1	27-50-02	P44A
206037-1	27-50-02	P44A
206037-1	27-51-01	P10A
206037-1	27-51-02	P44A
206037-1	28-40-01	P11A
206037-1	28-40-02	P10A
206037-1	28-40-02	P11A
206037-1	28-40-03	P10A
206037-1	28-40-03	P11A
206037-1	28-40-04	P10A
206037-1	28-40-04	P11A
206037-1	28-40-05	P10A
206037-1	28-40-05	P11A
206037-1	30-30-02	P10A
206037-1	32-60-01	P10A
206037-1	32-60-01	P11A
206037-1	32-60-01	P10A
206037-1	32-60-01	P11A
206037-1	33-45-01	P10A
206037-1	33-45-01	P11A
206037-1	33-45-01	P10A
206037-1	33-45-01	P11A
206037-1	91-12-01	P10A
206037-1	91-12-02	P10A
206037-1	91-12-02	P10A
206037-1	91-13-01	P11A
206060-1	21-50-01	P81A
206060-1	27-31-01	P33A
206060-1	28-40-01	P33A
206060-1	30-30-01	P33A
206060-1	32-30-01	P81A
206060-1	32-30-01	P81A
206060-1	32-30-02	P82A
206060-1	32-30-02	P82A
206060-1	32-31-01	P81A
206060-2	32-30-01	P82A
206060-2	32-30-01	P82A
206060-2	32-31-01	P82A
206060-2	32-31-02	P82A
206062-1	21-50-01	J81C
206062-1	21-50-01	P81B
206062-1	27-31-01	J33D
206062-1	27-31-01	P33B
206062-1	28-40-01	J33D
206062-1	28-40-01	P33D
206062-1	30-30-01	J33B
206062-1	30-30-01	P33B
206062-1	32-30-01	J82B
206062-1	32-30-01	J82B
206062-1	32-30-02	J82B
206062-1	32-30-02	P82B
206062-1	32-30-02	J82B
206062-1	32-30-02	P82B
206062-1	32-31-01	J82B
206062-1	32-31-02	J82B
206070-1	21-50-01	J11B
206070-1	21-50-01	P11B
206070-1	21-50-02	J11B

Part Number	GAMA/ATA Code	Reference Designator
206070-1	21-50-02	P11B
206070-1	21-50-03	J11B
206070-1	21-50-03	P11B
206070-1	21-50-03	J11B
206070-1	21-50-03	P11B
206070-1	21-50-03	J11B
206070-1	21-50-03	P11B
206070-1	21-50-03	J11B
206070-1	21-50-03	P11B
206070-1	27-31-02	J10B
206070-1	27-31-02	P10D
206070-1	27-31-02	J10B
206070-1	27-31-02	P10D
206070-1	27-50-01	J10B
206070-1	27-50-01	P10B
206070-1	27-50-02	J44C
206070-1	27-50-02	P44C
206070-1	27-50-02	J44C
206070-1	27-50-02	P44C
206070-1	27-51-01	J10B
206070-1	27-51-01	P10D
206070-1	27-51-02	J44C
206070-1	27-51-02	P44C
206070-1	28-40-01	J11B
206070-1	28-40-01	P11B
206070-1	28-40-02	J10B
206070-1	28-40-02	J11B
206070-1	28-40-02	P10D
206070-1	28-40-02	P11B
206070-1	28-40-03	J10B
206070-1	28-40-03	J11B
206070-1	28-40-03	P10D
206070-1	28-40-03	P11B
206070-1	28-40-04	J10B
206070-1	28-40-04	J11B
206070-1	28-40-04	P10D
206070-1	28-40-04	P11B
206070-1	28-40-05	J10B
206070-1	28-40-05	J11B
206070-1	28-40-05	P10D
206070-1	28-40-05	P11B
206070-1	30-30-02	J10B
206070-1	30-30-02	P10D
206070-1	32-30-01	J54C
206070-1	32-31-01	J54B
206070-1	32-60-01	J10B
206070-1	32-60-01	J11B
206070-1	32-60-01	J54B
206070-1	32-60-01	P10D
206070-1	32-60-01	P11B
206070-1	32-60-01	J10B
206070-1	32-60-01	J11B
206070-1	32-60-01	P10D
206070-1	32-60-01	P11B
206070-1	32-60-02	P16C
206070-1	33-10-01	J54C
206070-1	33-45-01	J10B
206070-1	33-45-01	J11B

Raytheon Aircraft

BEECH BONANZA WIRING DIAGRAM MANUAL

PART NUMBER INDEX (CONTINUED)

Part Number	GAMA/ATA Code	Reference Designator
206070-1	33-45-01	P10D
206070-1	33-45-01	P11B
206070-1	33-45-01	J10B
206070-1	33-45-01	J11B
206070-1	33-45-01	P10D
206070-1	33-45-01	P11B
206070-1	91-12-01	J10B
206070-1	91-12-01	P10B
206070-1	91-12-02	J10B
206070-1	91-12-02	P10B
206070-1	91-12-02	J10B
206070-1	91-12-02	P10B
206070-1	91-13-01	J11B
206070-1	91-13-01	P11B
206070-1	91-19-02	J54C
206070-1	91-19-02	P54C
206138-1	24-30-04	J54B
206138-1	24-30-04	P54B
206138-1	24-30-04	J54B
206138-1	24-30-04	P54B
206138-1	24-30-04	J54B
206138-1	24-30-04	P54B
206138-1	24-30-04	J54B
206138-1	24-30-04	P54B
206138-1	24-30-04	J54B
206138-1	24-30-04	P54B
206138-1	27-31-02	J54B
206138-1	27-31-02	P54B
206138-1	27-51-02	J54B
206138-1	27-51-02	P54B
206138-1	32-30-01	J54B
206138-1	32-30-01	P54B
206138-1	32-30-01	J54B
206138-1	32-30-01	P54B
206138-1	32-30-02	J54B
206138-1	32-30-02	P54B
206138-1	32-30-02	J54B
206138-1	32-30-02	P54B
206138-1	32-31-01	J54B
206138-1	32-31-01	P54B
206138-1	32-31-02	J54B
206138-1	32-31-02	P54B
206138-1	32-60-01	J54B
206138-1	32-60-01	P54B
206138-1	32-60-01	J54B
206138-1	32-60-01	P54B
206138-1	32-60-02	J54B
206138-1	32-60-02	P54B
206138-1	33-10-01	J54B
206138-1	33-10-01	P54B
206138-1	33-10-02	J54B
206138-1	33-10-02	P54B
206138-1	33-10-02	J54B
206138-1	33-10-02	P54B
206138-1	33-10-02	J54B
206138-1	33-10-02	P54B
206138-1	34-22-01	J54B
206138-1	34-22-01	P54B
206138-1	91-01-01	J54C
206138-1	91-01-01	P54C

Part Number	GAMA/ATA Code	Reference Designator
206138-1	91-01-02	J54C
206138-1	91-01-02	P54C
206138-1	91-02-01	J54B
206138-1	91-02-01	P54B
206138-1	91-02-02	J54B
206138-1	91-02-02	P54B
206138-1	91-19-03	J54C
206138-1	91-19-03	P54C
206138-1	91-19-03	J54C
206138-1	91-19-03	P54C
206150-1	24-30-04	P54A
206150-1	24-30-04	P54A
206150-1	24-30-04	P54A
206150-1	24-30-04	P54A
206150-1	27-31-02	P54A
206150-1	27-51-02	P54A
206150-1	32-30-01	P54A
206150-1	32-30-01	P54A
206150-1	32-30-02	P54A
206150-1	32-30-02	P54A
206150-1	32-31-01	P54A
206150-1	32-31-02	P54A
206150-1	32-60-01	P54A
206150-1	32-60-01	P54A
206150-1	32-60-02	P54A
206150-1	33-10-01	P54A
206150-1	33-10-02	P54A
206150-1	33-10-02	P54A
206150-1	34-22-01	P54A
206150-1	91-01-02	P54A
206150-1	91-02-01	P54A
206150-1	91-02-02	P54A
206150-1	91-19-03	P54A
206150-1	91-19-03	P54A
206151-2	24-30-04	J54A
206151-2	24-30-04	J54A
206151-2	24-30-04	J54A
206151-2	27-31-02	J54A
206151-2	27-51-02	J54A
206151-2	32-30-01	J54A
206151-2	32-30-01	J54A
206151-2	32-30-02	J54A
206151-2	32-30-02	J54A
206151-2	32-31-01	J54A
206151-2	32-31-02	J54A
206151-2	32-60-01	J54A
206151-2	32-60-01	J54A
206151-2	32-60-02	J54A
206151-2	33-10-01	J54A
206151-2	33-10-02	J54A
206151-2	33-10-02	J54A
206151-2	33-10-02	J54A
206151-2	34-22-01	J54A
206151-2	91-01-02	J54A
206151-2	91-02-01	J54A
206151-2	91-02-02	J54A

Raytheon Aircraft

BEECH BONANZA WIRING DIAGRAM MANUAL

PART NUMBER INDEX (CONTINUED)

Part Number	GAMA/ATA Code	Reference Designator
206151-2	91-19-03	J54A
206151-2	91-19-03	J54A
206152-1	32-30-01	J54A
206152-1	32-31-01	J54A
206152-1	32-60-01	J54A
206152-1	33-10-01	J54A
206152-1	91-01-01	J54A
206152-1	91-19-01	J54A
206153-1	21-50-01	J81A
206153-1	27-31-01	J33A
206153-1	28-40-01	J33A
206153-1	30-30-01	J33A
206153-1	32-30-01	J81A
206153-1	32-30-01	J82A
206153-1	32-30-01	J81A
206153-1	32-30-01	J82A
206153-1	32-30-02	J82A
206153-1	32-30-02	J82A
206153-1	32-31-01	J81A
206153-1	32-31-01	J82A
206153-1	32-31-02	J82A
206352	25-10-01	E23B
206352	25-10-01	E28B
206352	25-10-02	E23B
206352	25-10-03	E23B
206352	25-10-03	E28B
206618-1	91-15-01	P80B
206618-1	91-15-02	P80B
206705-2	21-50-02	J115A
206705-2	32-30-02	J115A
206705-2	32-31-02	J115A
206708-1	21-50-02	P115A
206708-1	32-30-02	P115A
206708-1	32-30-02	P115A
206966-1	21-50-02	J115B
206966-1	21-50-02	P115B
206966-1	32-30-02	J115B
206966-1	32-30-02	P115B
206966-1	32-30-02	J115B
206966-1	32-30-02	P115B
206966-1	32-31-02	J115B
207015-1	32-60-02	P16A
207016-1	32-60-02	LS10J1A
207017-1	32-30-01	P56A
207017-1	32-30-02	P56A
207017-1	32-31-01	P56A
207017-1	32-31-02	P56A
207017-1	32-60-01	P56A
207018-1	32-30-01	J56A
207018-1	32-31-02	J56A
207018-1	32-60-01	J56A
207359-1	21-52-01	J140
207360-1	21-52-01	P140
207377-1	28-40-04	P147A
207377-1	28-40-04	P148A
207377-1	28-40-05	P147A
207377-1	28-40-05	P148A

Part Number	GAMA/ATA Code	Reference Designator
207378-1	28-40-04	A27J1
207378-1	28-40-04	A28J1
207378-1	28-40-05	A27J1
207378-1	28-40-05	A28J1
207378-1	39-10-40	J1
207378-1	39-10-41	J1
207442-1	21-50-03	P116
207442-1	21-50-03	P116
207442-1	21-50-03	P116
207442-1	21-50-03	P116
207442-1	32-30-02	P116
207442-1	32-30-02	P116
207442-1	91-03-01	P116
207443-1	21-50-03	J116
207443-1	21-50-03	J116
207443-1	21-50-03	J116
207443-1	21-50-03	J116
207443-1	32-30-02	J116
207443-1	32-30-02	J116
207443-1	91-03-01	J116
207890	25-10-01	E23C
207890	25-10-01	E28C
207890	25-10-02	E23C
207890	25-10-03	E23C
207890	25-10-03	E28C
207946	25-10-01	E23D
207946	25-10-01	E28D
207946	25-10-02	E23D
207946	25-10-03	E23D
207946	25-10-03	E28D
210-16BL/24	77-30-01	M16A
25-0491-1	33-40-01	DS12B1
25-0491-1	33-40-02	DS12B
25-0491-1	33-40-02	DS12B
2506	33-20-01	XDS104
2506	33-20-01	XDS105
2506	33-20-02	XDS104
2506	33-20-02	XDS105
2506	33-42-01	XDS42
2506	33-42-01	XDS43
25530-1.5	34-22-01	S77
2565	33-20-01	XDS106
2565	33-20-01	XDS107
2565	33-20-01	XDS108
2565	33-20-01	XDS109
2565	33-20-02	XDS106
2565	33-20-02	XDS107
2565	33-20-02	XDS108
2565	33-20-02	XDS109
26006	27-32-01	S48
267	24-33-01	DS91B
267	24-33-02	DS91B
267	24-34-01	DS91B
267	24-34-02	DS91B
267	33-11-01	DS90
267	33-11-02	DS90
267	33-11-02	DS90
267	33-12-01	DS81B

Raytheon Aircraft

BEECH BONANZA WIRING DIAGRAM MANUAL

PART NUMBER INDEX (CONTINUED)

Part Number	GAMA/ATA Code	Reference Designator
267	33-12-01	DS82B
267	33-12-01	DS83B
267	33-12-01	DS84B
267	33-12-01	DS85B
267	33-12-02	DS81B
267	33-12-02	DS82B
267	33-12-02	DS83B
267	33-12-02	DS84B
267	33-12-02	DS85B
267	33-12-03	DS81B
267	33-12-03	DS82B
267	33-12-03	DS83B
267	33-12-03	DS84B
267	33-12-03	DS85B
267	33-14-01	DS120B
267	33-14-01	DS55B
267	33-14-01	DS56B
267	33-14-01	DS57B
267	33-14-01	DS58B
267	33-14-01	DS59B
267	33-14-01	DS60B
267	33-14-01	DS61B
267	33-14-01	DS62B
267	33-14-02	DS120B
267	33-14-02	DS56B
267	33-14-02	DS57B
267	33-14-02	DS58B
267	33-14-02	DS59B
267	33-14-02	DS60B
267	33-14-02	DS61B
267	33-14-02	DS62B
267	33-14-03	DS120B
267	33-14-03	DS56B
267	33-14-03	DS57B
267	33-14-03	DS58B
267	33-14-03	DS59B
267	33-14-03	DS60B
267	33-14-03	DS61B
267	33-14-03	DS62B
267	33-17-01	DS90
2962508	25-11-01	P95B
2965981	25-11-01	P95A
3E1964-3	30-60-01	E10
3E1964-3	30-60-01	E10
3E2062	30-60-01	E11
3E2062	30-60-01	E11
30-0502-5	33-42-01	DS42A
30-0502-5	33-42-01	DS43A
30-0516-13	33-40-02	DS11A
30-0516-13	33-40-02	DS11A
30-0815-1	33-40-01	DS11A
30-0815-5	33-40-01	DS11A
30-0815-5	33-40-02	DS11A
30-1	23-01-01	S10
30-1331-3	33-40-01	DS12A1
30-1331-3	33-40-01	DS13
30-1331-3	33-40-02	DS12A
30-1331-3	33-40-02	DS13

Part Number	GAMA/ATA Code	Reference Designator
30-1331-3	33-40-02	DS12A
30-1331-3	33-40-02	DS13
30-1467-101	33-40-02	DS12E
30-1467-101	33-40-02	DS12E
3006P-1-102	39-10-41	R9
3006P-1-501	39-10-40	R9
303	33-20-01	DS106
303	33-20-01	DS107
303	33-20-01	DS108
303	33-20-01	DS109
303	33-20-02	DS106
303	33-20-02	DS107
303	33-20-02	DS108
303	33-20-02	DS109
31-1705-3	33-42-01	DS42B
31-1705-3	33-42-01	DS43B
31-1740-9	33-40-02	DS11C
31-1740-9	33-40-02	DS11C
31-1745	33-40-02	DS11D
31-1745	33-40-02	DS11D
31-1780-1	33-40-02	DS11B
31-1780-1	33-40-02	DS11B
31-2440-3	33-40-01	DS11B
31-2440-5	33-40-02	DS11B
31-3792-7	33-40-01	DS12C1
31-3792-7	33-40-02	DS12C
31-3792-7	33-40-02	DS12C
313	24-33-01	DS30
313	24-33-02	DS30
313	24-34-01	DS30
313	24-34-02	DS30
313	33-18-01	DS28A
313	33-18-01	DS29A
313	33-18-01	DS30A
313	33-18-01	DS31A
313	33-18-01	DS32A
313	33-18-01	DS33A
313	33-18-01	DS34A
313	33-18-01	DS35A
313	33-18-01	DS36A
313	33-18-01	DS37A
313	33-18-01	DS38A
313	33-18-01	DS39A
313	33-18-01	DS28A
313	33-18-01	DS29A
313	33-18-01	DS30A
313	33-18-01	DS31A
313	33-18-01	DS32A
313	33-18-01	DS33A
313	33-18-01	DS34A
313	33-18-01	DS35A
313	33-18-01	DS36A
313	33-18-01	DS37A
313	33-18-01	DS38A
313	33-18-01	DS39A
319A209-1	27-32-01	B16C
319A209-4	27-32-01	B16C
327	32-60-01	DS144

Raytheon Aircraft

BEECH BONANZA WIRING DIAGRAM MANUAL

PART NUMBER INDEX (CONTINUED)

Part Number	GAMA/ATA Code	Reference Designator
327	32-60-01	DS145
327	32-60-01	DS146
327	32-60-01	DS147
327	32-60-01	DS144
327	32-60-01	DS145
327	32-60-01	DS146
327	32-60-01	DS147
327	32-60-02	DS148
327	33-10-01	DS45
327	33-10-01	DS97
327	33-10-02	DS26
327	33-10-02	DS45
327	33-10-02	DS97
327	33-10-02	DS151
327	33-10-02	DS152
327	33-10-02	DS26
327	33-10-02	DS45
327	33-10-02	DS97
327	33-10-02	DS121
327	33-10-02	DS151
327	33-10-02	DS152
327	33-10-02	DS26
327	33-10-02	DS45
327	33-10-02	DS97
327	33-11-01	DS19
327	33-11-01	DS95
327	33-11-01	DS96
327	33-11-02	DS19
327	33-11-02	DS95
327	33-11-02	DS96
327	33-11-02	DS19
327	33-11-02	DS95
327	33-11-02	DS96
327	33-13-01	DS112
327	33-13-01	DS113
327	33-13-01	DS114
327	33-13-01	DS115
327	33-13-01	DS116
327	33-13-01	DS117
327	33-13-01	DS118
327	33-13-02	DS112
327	33-13-02	DS113
327	33-13-02	DS114
327	33-13-02	DS115
327	33-13-02	DS116
327	33-13-02	DS117
327	33-13-02	DS118
327	33-13-03	DS112
327	33-13-03	DS113
327	33-13-03	DS114
327	33-13-03	DS115
327	33-13-03	DS116
327	33-13-03	DS117
327	33-13-03	DS118
327	33-14-01	DS101
327	33-14-02	DS101
327	33-14-03	DS101
327	33-17-01	DS101

Part Number	GAMA/ATA Code	Reference Designator
327	33-17-01	DS102
327	33-17-01	DS119
327	33-17-01	DS65
327	33-17-01	DS66
327	33-17-01	DS67
327	33-17-01	DS68
327	33-17-01	DS69
327	33-17-01	DS70
327	33-17-01	DS71
327	33-17-01	DS72
327	33-17-01	DS73
327	33-17-01	DS74
327	33-17-01	DS77
327	33-17-01	DS78
327	33-17-01	DS79
327	33-17-01	DS80
327	33-17-02	DS101
327	33-17-02	DS119
327	33-17-02	DS65
327	33-17-02	DS66
327	33-17-02	DS67
327	33-17-02	DS68
327	33-17-02	DS69
327	33-17-02	DS70
327	33-17-02	DS71
327	33-17-02	DS72
327	33-17-02	DS73
327	33-17-02	DS74
327	33-17-02	DS77
327	33-17-02	DS78
327	33-17-02	DS79
327	33-17-02	DS80
327	33-17-03	DS101
327	33-17-03	DS119
327	33-17-03	DS65
327	33-17-03	DS66
327	33-17-03	DS67
327	33-17-03	DS68
327	33-17-03	DS69
327	33-17-03	DS70
327	33-17-03	DS71
327	33-17-03	DS72
327	33-17-03	DS73
327	33-17-03	DS74
327	33-17-03	DS77
327	33-17-03	DS78
327	33-17-03	DS79
327	33-17-03	DS80
327	27-32-01	B16A
327	27-32-01	B16A
327	24-30-01	C11
327	24-30-01	C11
327	25-10-01	E23F
327	25-10-01	E28F
327	25-10-02	E23F
327	25-10-03	E23F
327	25-10-03	E28F
327	25-10-03	E28F
327	25-10-01	E23A

Raytheon Aircraft

BEECH BONANZA WIRING DIAGRAM MANUAL

PART NUMBER INDEX (CONTINUED)

Part Number	GAMA/ATA Code	Reference Designator
35-364160-5	25-10-01	E28A
35-364160-5	25-10-02	E23A
35-364160-5	25-10-03	E23A
35-364160-9	25-10-03	E28A
35-364171-27	32-31-01	S32
35-364171-27	32-31-02	S32
35-380053-11	24-33-01	S56
35-380053-11	24-33-02	S56
35-380053-11	24-34-01	S56
35-380053-11	24-34-02	S56
35-380053-11	32-31-01	S30A
35-380053-11	32-31-02	S30A
35-380053-21	24-30-01	S29
35-380053-21	24-30-01	S29
35-380053-21	24-30-02	S29
35-380053-21	24-30-02	S29
35-380053-21	24-30-02	S29
35-380053-21	24-30-02	S29
35-380053-21	24-30-03	S29
35-380053-21	24-30-03	S29
35-380053-21	24-30-04	S29
35-380053-21	24-30-04	S29
35-380053-21	24-30-04	S29
35-380053-21	24-30-04	S29
35-380053-21	24-30-04	S29
35-380053-21	28-20-01	S11
35-380053-21	28-20-02	S11
35-380053-21	28-20-04	S11
35-380053-21	28-20-05	S11
35-380053-9	24-33-01	S55
35-380053-9	24-33-02	S55
35-380126-15	33-16-01	DS14
35-380132-13	24-31-01	CB15
35-380132-13	24-50-01	CB15
35-380132-13	24-50-02	CB15
35-380132-13	24-50-02	CB15
35-380132-13	24-51-01	CB15
35-380132-13	24-51-02	CB15
35-380132-13	24-51-02	CB15
35-380132-13	24-52-01	CB15
35-380132-13	24-52-02	CB15
35-380132-13	24-52-02	CB15
35-380132-3	24-50-01	CB44
35-380132-3	24-50-02	CB44
35-380132-3	24-50-02	CB44
35-380132-3	24-51-01	CB44
35-380132-3	24-51-02	CB44
35-380132-3	24-51-02	CB44
35-380132-3	24-52-01	CB44
35-380132-3	24-52-02	CB44
35-380132-3	24-52-02	CB44
35-380132-3	30-30-01	CB44
35-380132-3	30-30-02	CB44
35-380132-33	21-52-01	CB34
35-380132-33	21-52-01	CB34
35-380132-33	24-50-02	CB34
35-380132-33	24-50-02	CB34
35-380132-33	24-51-02	CB34
35-380132-33	24-51-02	CB34
35-380132-33	24-52-02	CB34
35-380132-33	24-52-02	CB34

Part Number	GAMA/ATA Code	Reference Designator
35-380132-39	24-50-02	CB58
35-380132-39	24-51-02	CB58
35-380132-39	24-51-02	CB58
35-380132-39	24-52-02	CB58
35-380132-39	24-52-02	CB58
35-380132-39	34-22-01	CB58
35-380132-39	36-20-02	CB64
35-380132-39	36-20-02	CB64
35-380132-41	24-50-01	CB54
35-380132-41	24-50-02	CB54
35-380132-41	24-50-02	CB54
35-380132-41	24-51-01	CB54
35-380132-41	24-51-02	CB54
35-380132-41	24-51-02	CB54
35-380132-41	24-52-01	CB54
35-380132-41	24-52-02	CB54
35-380132-41	24-52-02	CB54
35-380132-41	24-52-02	CB54
35-380132-41	33-11-01	CB54
35-380132-41	33-11-02	CB54
35-380132-41	33-11-02	CB54
35-380132-41	33-45-01	CB54
35-380132-41	33-45-01	CB54
35-380132-43	24-50-01	CB51
35-380132-43	24-50-01	CB53
35-380132-43	24-50-01	CB55
35-380132-43	24-50-01	CB56
35-380132-43	24-50-02	CB51
35-380132-43	24-50-02	CB53
35-380132-43	24-50-02	CB55
35-380132-43	24-50-02	CB56
35-380132-43	24-50-02	CB55
35-380132-43	24-50-02	CB56
35-380132-43	24-51-01	CB51
35-380132-43	24-51-01	CB53
35-380132-43	24-51-01	CB55
35-380132-43	24-51-01	CB56
35-380132-43	24-51-02	CB51
35-380132-43	24-51-02	CB53
35-380132-43	24-51-02	CB55
35-380132-43	24-51-02	CB56
35-380132-43	24-51-02	CB53
35-380132-43	24-51-02	CB55
35-380132-43	24-51-02	CB56
35-380132-43	24-52-01	CB51
35-380132-43	24-52-01	CB53
35-380132-43	24-52-01	CB55
35-380132-43	24-52-01	CB56
35-380132-43	24-52-02	CB51
35-380132-43	24-52-02	CB53
35-380132-43	24-52-02	CB55
35-380132-43	24-52-02	CB56
35-380132-43	24-52-02	CB51
35-380132-43	24-52-02	CB53
35-380132-43	24-52-02	CB55
35-380132-43	24-52-02	CB56

Raytheon Aircraft

BEECH BONANZA WIRING DIAGRAM MANUAL

PART NUMBER INDEX (CONTINUED)

Part Number	GAMA/ATA Code	Reference Designator
36-364030-5	33-44-02	AB
36-364030-7	33-44-02	AB
36-364030-7	33-44-02	AB
36-364030-7	33-44-02	AB
36-364036-3	33-44-02	DS140G
36-364036-3	33-44-02	DS140G
36-364036-7	33-44-02	DS141G
36-364036-7	33-44-02	DS141G
36-364036-7	33-44-02	DS141G
36-364036-7	33-44-02	DS141N
36-364036-7	33-44-02	DS141N
36-380000-3	24-30-01	A16
36-380000-3	24-30-01	A16
36-380000-3	24-30-02	A16
36-380000-3	24-30-02	A16
36-380000-3	24-30-03	A16
36-380000-3	24-30-03	A16
36-380000-3	24-30-04	A16
36-380000-3	24-30-04	A16
36-380000-3	24-30-04	A16
36-380000-3	24-30-04	A16
36-380019-15	33-16-01	DS16
36-380019-23	33-16-01	DS16
36-380019-25	33-16-01	DS16
36-380019-33	33-16-01	DS16
36-380019-35	33-16-01	DS16
36-380019-37	33-16-01	DS16
36-380019-9	33-16-01	DS16
36-380021-27	21-50-01	A22
36-380021-27	21-50-02	A22
36-380021-27	21-50-03	A22
36-380021-27	21-50-03	A22
36-380021-27	21-50-03	A22
36-380021-27	21-50-03	A22
36-380021-33	21-50-03	A22
36-380027-29	21-50-01	B24
36-380027-29	21-50-02	B24
36-380027-29	21-50-03	B24
36-380027-29	21-50-03	B24
36-380027-29	21-50-03	B24
36-380027-29	21-50-03	B24
36-380027-29	21-50-03	B24
36-380027-37	21-50-03	B24
36-380044-1	77-20-01	M21
36-380044-11	77-20-01	M21
36-380044-15	77-20-01	M21
36-380044-17	77-20-01	M21
36-380044-19	77-20-01	M21
36-380044-3	77-20-01	M21
36-380044-5	77-20-01	M21
36-380044-7	77-20-01	M21
36-380044-9	77-20-01	M21
36-380048-1	24-33-01	G17
36-380048-1	24-33-02	G17
36-380048-1	24-34-01	G17
36-380048-1	24-34-02	G17
36-380056-1	24-33-01	VR12
36-380056-1	24-33-02	VR12
36-380056-1	24-34-01	VR12

Part Number	GAMA/ATA Code	Reference Designator
36-380056-3	24-33-02	VR12
36-380056-3	24-34-02	VR12
36-380056-5	24-31-01	VR11
36-380059-1	24-30-01	BT10
36-380059-1	24-30-01	BT10
36-380059-1	24-30-02	BT10
36-380059-1	24-30-02	BT10
36-380059-1	24-30-03	BT10
36-380059-1	24-30-03	BT10
36-380059-1	24-30-04	BT10
36-380059-1	24-30-04	BT10
36-380059-1	24-30-04	BT10
36-380059-1	24-30-04	BT10
36-380070-3	73-30-01	M6
36-380071-3	73-30-01	M6
36-380072-3	73-30-01	M6
36-380073-3	73-30-01	M6
36-380074-1	33-16-01	DS16
36-380074-3	33-16-01	DS16
36-380074-5	33-16-01	DS16
36-380096-1	24-31-01	VR11
36-5009-3P	36-20-02	A1
36-5011-3P	36-20-02	A1
36-9008-1S	28-20-03	A1
36112	33-44-02	DS141X
36112	33-44-02	DS141X
36112	33-44-02	DS141Z
3810P502	39-10-10	A13R1
39D507G050GL4	24-30-02	C11
39D507G050GL4	24-30-02	C11
39D507G050GL4	24-30-03	C11
39D507G050GL4	24-30-03	C11
39D507G050GL4	24-30-04	C11
39D507G050GL4	24-30-04	C11
39D507G050GL4	24-30-04	C11
39D507G050GL4	24-30-04	C11
39D507G050GL4	24-30-04	C11
39D507G050GL4	24-33-01	C10
39D507G050GL4	24-33-02	C10
39D507G050GL4	24-34-01	C10
39D507G050GL4	24-34-02	C10
40-0100-3C	33-44-02	DS141V
40-0100-3C	33-44-02	DS141V
40-0100-3C	33-44-02	DS141X
41-0109-3	33-44-02	DS141M
41-0109-3	33-44-02	DS141M
41-0190-1	33-44-01	DS140D
41-0190-1	33-44-01	DS140F
41-0190-1	33-44-02	DS140F
41-0190-1	33-44-02	DS140T
41-0190-1	33-44-02	DS140F
41-0190-1	33-44-02	DS140T
41-0190-1	33-44-02	DS141F
41-0190-1	33-44-02	DS141F
41-0190-3	33-44-01	DS141F
41-0190-3	33-44-02	DS141F
41-0190-3	33-44-02	DS141F
41-0190-3	33-44-02	DS141T

Raytheon Aircraft

BEECH BONANZA WIRING DIAGRAM MANUAL

PART NUMBER INDEX (CONTINUED)

Part Number	GAMA/ATA Code	Reference Designator
41-0832-9	33-44-02	DS141ZA
41-0832-9	33-44-02	DS141ZA
41-0832-9	33-44-02	DS141ZC
4169-143	24-33-01	XDS30
4169-143	24-33-02	XDS30
4169-143	24-34-01	XDS30
4169-143	24-34-02	XDS30
4169-143	33-18-01	XDS28
4169-143	33-18-01	XDS29
4169-143	33-18-01	XDS30
4169-143	33-18-01	XDS31
4169-143	33-18-01	XDS32
4169-143	33-18-01	XDS33
4169-143	33-18-01	XDS34
4169-143	33-18-01	XDS35
4169-143	33-18-01	XDS36
4169-143	33-18-01	XDS37
4169-143	33-18-01	XDS38
4169-143	33-18-01	XDS39
4169-143	33-18-01	XDS28
4169-143	33-18-01	XDS29
4169-143	33-18-01	XDS30
4169-143	33-18-01	XDS31
4169-143	33-18-01	XDS32
4169-143	33-18-01	XDS33
4169-143	33-18-01	XDS34
4169-143	33-18-01	XDS35
4169-143	33-18-01	XDS36
4169-143	33-18-01	XDS37
4169-143	33-18-01	XDS38
4169-143	33-18-01	XDS39
435-205-104	24-33-01	CB26
435-205-104	24-33-01	CB28
435-205-104	24-33-01	CB30
435-205-104	24-34-01	CB26
435-205-104	24-34-01	CB28
435-205-104	24-34-01	CB30
435-205-104	24-50-01	CB12
435-205-104	24-50-01	CB13
435-205-104	24-50-01	CB14
435-205-104	24-50-01	CB16
435-205-104	24-50-01	CB18
435-205-104	24-50-01	CB22
435-205-104	24-50-01	CB23
435-205-104	24-50-01	CB24
435-205-104	24-50-01	CB25
435-205-104	24-50-01	CB26
435-205-104	24-50-01	CB27
435-205-104	24-50-01	CB28
435-205-104	24-50-01	CB29
435-205-104	24-50-01	CB30
435-205-104	24-50-01	CB35
435-205-104	24-51-01	CB12
435-205-104	24-51-01	CB13
435-205-104	24-51-01	CB14
435-205-104	24-51-01	CB16
435-205-104	24-51-01	CB18
435-205-104	24-51-01	CB22

Part Number	GAMA/ATA Code	Reference Designator
435-205-104	24-51-01	CB23
435-205-104	24-51-01	CB24
435-205-104	24-51-01	CB25
435-205-104	24-51-01	CB26
435-205-104	24-51-01	CB27
435-205-104	24-51-01	CB28
435-205-104	24-51-01	CB29
435-205-104	24-51-01	CB30
435-205-104	24-51-01	CB35
435-205-104	24-51-02	CB12
435-205-104	24-51-02	CB16
435-205-104	24-51-02	CB18
435-205-104	24-51-02	CB22
435-205-104	24-51-02	CB23
435-205-104	24-51-02	CB24
435-205-104	24-51-02	CB25
435-205-104	24-51-02	CB26
435-205-104	24-51-02	CB27
435-205-104	24-51-02	CB28
435-205-104	24-51-02	CB29
435-205-104	24-51-02	CB30
435-205-104	24-51-02	CB35
435-205-104	24-51-02	CB12
435-205-104	24-51-02	CB16
435-205-104	24-51-02	CB18
435-205-104	24-51-02	CB22
435-205-104	24-51-02	CB23
435-205-104	24-51-02	CB24
435-205-104	24-51-02	CB25
435-205-104	24-51-02	CB26
435-205-104	24-51-02	CB27
435-205-104	24-51-02	CB28
435-205-104	24-51-02	CB29
435-205-104	24-51-02	CB30
435-205-104	24-51-02	CB35
435-205-104	24-52-01	CB12
435-205-104	24-52-01	CB13
435-205-104	24-52-01	CB14
435-205-104	24-52-01	CB16
435-205-104	24-52-01	CB18
435-205-104	24-52-01	CB22
435-205-104	24-52-01	CB23
435-205-104	24-52-01	CB24
435-205-104	24-52-01	CB25
435-205-104	24-52-01	CB26
435-205-104	24-52-01	CB27
435-205-104	24-52-01	CB28
435-205-104	24-52-01	CB29
435-205-104	24-52-01	CB30
435-205-104	24-52-01	CB35
435-205-104	25-10-01	CB14
435-205-104	25-10-02	CB14
435-205-104	25-10-03	CB14
435-205-104	25-11-01	CB16
435-205-104	25-11-02	CB16
435-205-104	25-12-01	CB16
435-205-104	25-12-02	CB16
435-205-104	25-12-03	CB16

Raytheon Aircraft

BEECH BONANZA WIRING DIAGRAM MANUAL

PART NUMBER INDEX (CONTINUED)

Part Number	GAMA/ATA Code	Reference Designator
435-205-104	27-31-01	CB12
435-205-104	27-31-02	CB12
435-205-104	27-32-01	CB35
435-205-104	27-50-02	CB16
435-205-104	27-51-01	CB16
435-205-104	27-51-02	CB16
435-205-104	28-40-01	CB30
435-205-104	28-40-02	CB30
435-205-104	28-40-03	CB30
435-205-104	32-30-01	CB18
435-205-104	32-31-01	CB13
435-205-104	32-31-01	CB18
435-205-104	32-60-01	CB29
435-205-104	33-10-01	CB23
435-205-104	33-10-01	CB29
435-205-104	33-10-02	CB23
435-205-104	33-10-02	CB29
435-205-104	33-11-01	CB24
435-205-104	33-11-02	CB16
435-205-104	33-15-01	CB25
435-205-104	33-15-01	CB27
435-205-104	33-15-02	CB25
435-205-104	33-15-02	CB27
435-205-104	33-20-01	CB24
435-205-104	34-20-01	CB22
435-205-104	36-20-02	CB25
435-205-104	36-20-02	CB25
435-205-104	74-30-01	CB26
435-205-104	74-30-02	CB26
435-205-104	77-20-01	CB28
435-210-104	21-50-01	CB33
435-210-104	24-50-01	CB31
435-210-104	24-50-01	CB33
435-210-104	24-50-01	CB33
435-210-104	24-50-02	CB33
435-210-104	24-51-01	CB31
435-210-104	24-51-01	CB33
435-210-104	24-51-02	CB31
435-210-104	24-51-02	CB33
435-210-104	24-51-02	CB33
435-210-104	24-52-01	CB31
435-210-104	24-52-01	CB33
435-210-104	24-52-02	CB33
435-210-104	24-52-02	CB33
435-210-104	28-20-01	CB31
435-210-104	28-20-02	CB31
435-210-104	28-20-03	CB31
435-210-104	28-20-03	CB31
435-210-104	28-20-04	CB31
435-210-104	28-20-05	CB31
435-215-104	21-50-01	CB33
435-215-104	21-50-02	CB33
435-215-104	24-50-01	CB17
435-215-104	24-50-01	CB33
435-215-104	24-50-01	CB33
435-215-104	24-51-01	CB17
435-215-104	24-51-02	CB17

Part Number	GAMA/ATA Code	Reference Designator
435-215-104	24-51-02	CB33
435-215-104	24-51-02	CB17
435-215-104	24-52-01	CB17
435-215-104	27-50-01	CB17
435-215-104	27-50-02	CB17
4418	39-10-03	A10A1R23
4522	24-33-01	XF11
4522	24-33-02	XF11
4522	24-34-01	XF11
4522	24-34-02	XF11
4522	34-22-01	XF33
4522	36-20-02	XF30
4522	36-20-02	XF30
4532	21-50-01	XF19
4532	21-50-02	XF19
4532	21-50-03	XF19
4532	21-50-03	XF19
4532	21-50-03	XF19
4532	24-30-01	XF15
4532	24-30-01	XF15
4532	24-30-02	XF15
4532	24-30-02	XF15
4532	24-30-03	XF15
4532	24-30-03	XF15
4532	24-30-04	XF15
4532	24-30-04	XF15
4532	24-30-04	XF15
4532	24-30-04	XF15
4532	25-11-01	XF15
4532	25-11-02	XF15
4532	25-12-01	XF15
4532	25-12-02	XF15
4532	25-12-03	XF15
4532	33-42-01	XF19
4587	27-32-01	R45
4596	33-43-01	DS21
4596	33-46-01	DS20
50-380048-1	24-33-01	K10
50-380048-1	24-33-01	K11
50-380048-1	24-33-01	K13
50-380048-1	24-33-02	K10
50-380048-1	24-33-02	K11
50-380048-1	24-33-02	K13
50-380048-1	24-34-01	K10
50-380048-1	24-34-01	K11
50-380048-1	24-34-01	K13
50-380048-1	24-34-02	K10
50-380048-1	24-34-02	K11
50-380048-1	24-34-02	K13
50-380048-1	27-50-02	K20
50-380048-1	27-50-02	K21
50-380048-1	27-50-02	K20
50-380048-1	27-50-02	K21
50-380048-1	28-20-03	K22
50-380048-1	32-31-01	K19
50-380048-1	32-31-02	K19
50-380048-11	91-03-01	A23K1

Raytheon Aircraft

BEECH BONANZA WIRING DIAGRAM MANUAL

PART NUMBER INDEX (CONTINUED)

Part Number	GAMA/ATA Code	Reference Designator
50-380125	27-32-01	B16B
50-380125	27-32-01	B16B
50-384040-1	30-30-01	HR23
50-384040-1	30-30-02	HR23
50-384112-1	32-30-01	A10A1K1
50-384112-1	32-30-02	A10A1K1
50-384112-1	39-10-01	A10A1A1K2
50-384112-1	39-10-02	A10A1A1K2
50-384112-1	39-10-03	A10A1K1
50-384112-1	91-03-01	A23K2
55-0069-1	33-44-02	DS141Z
55-0069-1	33-44-02	DS141Z
55-0069-1	33-44-02	DS141ZB
55-0221	33-40-01	DS12D1
55-0221-1	33-40-02	DS12D
55-0221-1	33-40-02	DS12D
55-3025-1S	24-30-01	Y1B
55-3025-1S	24-30-02	Y1B
55-3025-1S	24-30-03	Y1B
55-3025-1S	24-30-04	Y1B
552-00S	39-10-20	A19A1R2
58-360006-1	24-30-01	Y1C
58-360006-1	24-30-02	Y1C
58-360006-1	24-30-03	Y1C
58-360006-1	24-30-04	Y1C
58-361015	24-30-04	XF32
58-361015-1	24-30-01	Y1D
58-361015-1	24-30-02	Y1D
58-361015-1	24-30-03	Y1D
58-361015-1	24-30-04	Y1D
58-364041-5	39-10-10	A13W1
58-364041-9	28-40-01	A13
58-364041-9	28-40-01	A14
58-364041-9	28-40-02	A13
58-364041-9	28-40-02	A14
58-364041-9	28-40-03	A13
58-364041-9	28-40-03	A14
58-364041-9	39-10-10	A13/A14
58-364054-1	39-10-01	A10A1A1W1
58-364054-7	39-10-03	A10A1W1
58-364055-1	39-10-01	A10A1A1
58-364055-1	91-02-01	A10A1A1
58-364055-1	91-02-02	A10A1A1
58-364055-7	39-10-02	A10A1A1
58-364055-7	91-02-03	A10A1
58-364055-9	39-10-03	A10A1
58-364056	91-02-01	A10A1
58-364056-1	91-02-01	A10
58-364056-1	91-02-02	A10A1
58-364056-13	91-02-02	A10
58-364056-15	32-30-01	A10
58-364056-15	32-30-02	A10
58-364056-15	91-02-03	A10
58-364056-9	32-30-01	A10A1
58-364056-9	32-30-02	A10A1
58-364058-13	28-40-04	A27
58-364058-13	28-40-04	A28
58-364058-13	28-40-05	A27

Part Number	GAMA/ATA Code	Reference Designator
58-364058-13	39-10-41	A27/A28
58-364058-3	28-40-04	A27
58-364058-3	28-40-04	A28
58-364058-3	28-40-05	A28
58-364058-3	39-10-40	A27/A28
58-364059-1	39-10-40	W1
58-364059-1	39-10-41	W1
58-364061-1	91-03-01	A23
58-380009-1	27-51-01	MT2
58-380009-1	27-51-02	MT2
58-380022-11	24-33-01	DS91A
58-380022-11	24-33-02	DS91A
58-380022-11	24-34-01	DS91A
58-380022-11	24-34-02	DS91A
58-380022-11	33-12-01	DS81A
58-380022-11	33-12-01	DS82A
58-380022-11	33-12-01	DS83A
58-380022-11	33-12-01	DS84A
58-380022-11	33-12-01	DS85A
58-380022-11	33-12-02	DS81A
58-380022-11	33-12-02	DS82A
58-380022-11	33-12-02	DS83A
58-380022-11	33-12-02	DS84A
58-380022-11	33-12-02	DS85A
58-380022-11	33-12-03	DS81A
58-380022-11	33-12-03	DS82A
58-380022-11	33-12-03	DS83A
58-380022-11	33-12-03	DS84A
58-380022-11	33-12-03	DS85A
58-380022-11	33-14-01	DS120A
58-380022-11	33-14-01	DS55A
58-380022-11	33-14-01	DS56A
58-380022-11	33-14-01	DS57A
58-380022-11	33-14-01	DS58A
58-380022-11	33-14-01	DS59A
58-380022-11	33-14-01	DS60A
58-380022-11	33-14-01	DS61A
58-380022-11	33-14-01	DS62A
58-380022-11	33-14-02	DS120A
58-380022-11	33-14-02	DS56A
58-380022-11	33-14-02	DS57A
58-380022-11	33-14-02	DS58A
58-380022-11	33-14-02	DS59A
58-380022-11	33-14-02	DS60A
58-380022-11	33-14-02	DS61A
58-380022-11	33-14-02	DS62A
58-380022-11	33-14-03	DS120A
58-380022-11	33-14-03	DS56A
58-380022-11	33-14-03	DS57A
58-380022-11	33-14-03	DS58A
58-380022-11	33-14-03	DS59A
58-380022-11	33-14-03	DS60A
58-380022-11	33-14-03	DS61A
58-380022-11	33-14-03	DS62A
58-380050-11	28-40-01	M17
58-380050-11	28-40-01	M18
58-380050-11	28-40-02	M17
58-380050-11	28-40-02	M18

Raytheon Aircraft

BEECH BONANZA WIRING DIAGRAM MANUAL

PART NUMBER INDEX (CONTINUED)

Part Number	GAMA/ATA Code	Reference Designator
58-380050-19	28-40-05	M17
58-380050-19	28-40-05	M18
58-380051	28-40-01	M29
58-380051	28-40-01	M30
58-380051	28-40-02	M29
58-380051	28-40-02	M30
58-380051	28-40-03	M29
58-380051	28-40-03	M30
58-380051-17	28-40-05	M17
58-380051-17	28-40-05	M18
58-380074-11	28-40-01	M17
58-380074-11	28-40-01	M18
58-380074-11	28-40-02	M17
58-380074-11	28-40-02	M18
58-380074-17	28-40-05	M17
58-380074-17	28-40-05	M18
58-380075-17	28-40-05	M17
58-380075-17	28-40-05	M18
58-380077-3	25-11-01	M26
58-380085-3	34-20-01	M19
58-380090-5	32-30-01	B21
58-380090-5	32-30-01	B21
58-380090-5	32-30-02	B21
58-380090-5	32-30-02	B21
58-380090-5	32-31-01	B21
58-380090-5	32-31-02	B21
58-380101-1	33-15-01	A21MG1
58-380101-1	33-15-02	A21MG1
58-380108-1	21-52-01	B19
58-384001-35	27-51-01	M25
58-384001-35	27-51-02	M25
60-1750-3	33-40-01	PS11
60-1750-3	33-40-02	PS11
60-1750-3	33-40-02	PS11
60-369025-2	24-30-03	XF26
60-369025-2	24-30-03	XF26
60-369025-2	24-30-04	XF26
60-369025-2	24-30-04	XF26
60-369025-2	24-30-04	XF26
60-369025-2	24-30-04	XF26
60-384038	24-33-01	M15
60-384038	24-33-02	M15
60-384038	24-34-01	M15
60-384038	24-34-02	M15
60-389012-9	33-10-01	S57
60-389012-9	33-10-02	S57
60-389012-9	33-10-02	S57
60-389012-9	33-10-02	S57
6041H189	24-30-01	K15
6041H189	24-30-01	K15
6041H189	24-30-02	K15
6041H189	24-30-02	K15
6041H189	24-30-03	K15
6041H189	24-30-03	K15
6041H189	24-30-04	K15
6041H189	24-30-04	K15
6041H189	24-30-04	K15
6041H189	24-30-04	K15

Part Number	GAMA/ATA Code	Reference Designator
6041H190	24-30-01	K14
6041H190	24-30-01	K14
6041H190	24-30-02	K14
6041H190	24-30-02	K14
6041H190	24-30-03	K14
6041H190	24-30-03	K14
6041H190	24-30-04	K14
6041H190	24-30-04	K14
6041H190	24-30-04	K14
6041H190	24-30-04	K14
6046H39A	32-30-01	K17
6046H39A	32-31-01	K17
6046H39B	32-30-01	K17
6046H39B	32-30-01	K17
6046H39B	32-30-02	K17
6046H39B	32-30-02	K17
6046H39B	32-31-01	K17
6046H39B	32-31-02	K17
60617-1	24-33-01	P31C
60617-1	24-33-02	P31C
60617-1	24-34-01	P31C
60617-1	24-34-02	P31C
60617-1	25-10-01	P73B
60617-1	25-10-01	P79B
60617-1	25-10-02	P79B
60617-1	25-10-03	P73B
60617-1	25-10-03	P79B
60617-1	27-50-02	P30B
60617-1	27-50-02	P53B
60617-1	27-50-02	P30B
60617-1	27-50-02	P53B
60617-1	27-51-01	P75B
60617-1	28-20-01	P49B
60617-1	28-20-02	P49B
60617-1	28-20-02	P50B
60617-1	28-20-04	P49B
60617-1	28-20-05	P49B
60617-1	28-20-05	P50B
60617-1	28-40-01	P63B
60617-1	28-40-01	P64B
60617-1	28-40-02	P63B
60617-1	28-40-02	P64B
60617-1	28-40-03	P63B
60617-1	28-40-03	P64B
60617-1	32-60-01	P59B
60617-1	32-60-01	P59B
60617-1	32-60-02	P31C
60617-1	33-10-01	P51B
60617-1	33-10-02	P51B
60617-1	33-10-02	P51B
60617-1	33-10-02	P51B
60617-1	33-11-01	J65B
60617-1	33-11-01	P31C
60617-1	33-11-02	J65B
60617-1	33-11-02	P31C
60617-1	33-11-02	J65B
60617-1	33-11-02	P31C
60617-1	33-12-02	P121B

Raytheon Aircraft

BEECH BONANZA WIRING DIAGRAM MANUAL

PART NUMBER INDEX (CONTINUED)

Part Number	GAMA/ATA Code	Reference Designator
60617-1	33-12-02	P122B
60617-1	33-13-02	P122B
60617-1	33-14-02	P123B
60617-1	33-14-02	P124B
60617-1	33-15-01	P30B
60617-1	33-15-02	P30B
60617-1	33-17-02	P123B
60617-1	33-17-02	P124B
60617-1	33-18-01	P31B
60617-1	33-18-01	P31B
60617-1	33-20-01	P57B
60617-1	33-20-02	P156B
60617-1	33-20-02	P157B
60617-1	33-20-02	P57B
60617-1	33-40-01	P67B
60617-1	33-40-02	P67B
60617-1	33-40-02	P67B
60617-1	33-44-01	P58B
60617-1	33-44-01	P58B
60617-1	33-44-01	P69B
60617-1	33-44-01	P71B
60617-1	33-44-01	P71B
60617-1	33-44-02	P42B
60617-1	33-44-02	P43B
60617-1	33-44-02	P71B
60617-1	33-44-02	P42B
60617-1	33-44-02	P43B
60617-1	33-44-02	P69B
60617-1	33-44-02	P71B
60617-1	33-45-01	P66B
60617-1	33-45-01	P77B
60617-1	33-45-01	P78B
60617-1	33-45-01	P66B
60617-1	33-45-01	P77B
60617-1	33-45-01	P78B
60617-1	91-01-01	P75B
60617-1	91-21-01	P85B
60617-1	91-21-01	P85B
60617-1	91-22-01	P31C
60617-1	91-22-01	P31C
60617-5	25-11-02	P135B
60618-1	24-33-01	J31C
60618-1	24-33-02	J31C
60618-1	24-34-01	J31C
60618-1	24-34-02	J31C
60618-1	25-10-01	J73C
60618-1	25-10-01	J79C
60618-1	25-10-02	J79C
60618-1	25-10-03	J73C
60618-1	25-10-03	J79C
60618-1	27-50-02	J30B
60618-1	27-50-02	J53B
60618-1	27-50-02	J30B
60618-1	27-50-02	J53B
60618-1	27-51-01	J75B

Part Number	GAMA/ATA Code	Reference Designator
60618-1	28-20-01	J49B
60618-1	28-20-02	J49B
60618-1	28-20-02	J50B
60618-1	28-20-04	J49B
60618-1	28-20-05	J49B
60618-1	28-20-05	J50B
60618-1	28-40-01	J63B
60618-1	28-40-01	J64B
60618-1	28-40-02	J63B
60618-1	28-40-02	J64B
60618-1	28-40-03	J63B
60618-1	28-40-03	J64B
60618-1	32-30-01	J85B
60618-1	32-30-01	J85B
60618-1	32-30-02	J85B
60618-1	32-30-02	J85B
60618-1	32-31-01	J85B
60618-1	32-31-02	J85B
60618-1	32-60-01	J59B
60618-1	32-60-01	J85B
60618-1	32-60-01	J59B
60618-1	32-60-01	J85B
60618-1	32-60-01	J59B
60618-1	32-60-01	J85B
60618-1	33-10-01	J51B
60618-1	33-10-02	J51B
60618-1	33-10-02	J51B
60618-1	33-10-02	J51B
60618-1	33-11-01	J31C
60618-1	33-11-01	P65B
60618-1	33-11-02	J31C
60618-1	33-11-02	P65B
60618-1	33-11-02	J31C
60618-1	33-11-02	P65B
60618-1	33-12-02	J121C
60618-1	33-12-02	J122C
60618-1	33-13-02	J122C
60618-1	33-14-02	J123C
60618-1	33-14-02	J124C
60618-1	33-15-01	J30B
60618-1	33-15-02	J30B
60618-1	33-17-02	J123C
60618-1	33-17-02	J124C
60618-1	33-18-01	J31B
60618-1	33-18-01	J31B
60618-1	33-20-01	J57B
60618-1	33-20-02	J156B
60618-1	33-20-02	J57B
60618-1	33-40-01	J67B
60618-1	33-40-02	J67B
60618-1	33-40-02	J67B
60618-1	33-44-01	J58B
60618-1	33-44-01	J69B
60618-1	33-44-01	J71B
60618-1	33-44-02	J42B
60618-1	33-44-02	J43B
60618-1	33-44-02	J71B
60618-1	33-44-02	J42B
60618-1	33-44-02	J43B
60618-1	33-44-02	J71B

Raytheon Aircraft

BEECH BONANZA WIRING DIAGRAM MANUAL

PART NUMBER INDEX (CONTINUED)

Part Number	GAMA/ATA Code	Reference Designator
60618-1	33-44-02	J42B
60618-1	33-44-02	J43B
60618-1	33-44-02	J69B
60618-1	33-44-02	J71B
60618-1	33-45-01	J66B
60618-1	33-45-01	J77B
60618-1	33-45-01	J78B
60618-1	33-45-01	J85B
60618-1	33-45-01	J66B
60618-1	33-45-01	J77B
60618-1	33-45-01	J78B
60618-1	33-45-01	J85B
60618-1	77-20-01	P22B
60618-1	91-01-01	J75B
60618-1	91-21-01	J85B
60618-1	91-21-01	J85B
60618-1	91-22-01	J31C
60619-1	27-50-01	P74B
60619-1	27-50-02	P53C
60619-1	27-50-02	P53C
60619-1	33-20-02	J157B
60620-1	25-10-01	J73B
60620-1	25-10-01	J79B
60620-1	25-10-02	J79B
60620-1	25-10-03	J73B
60620-1	25-10-03	J79B
60620-1	27-50-02	J53C
60620-1	27-50-02	J53C
6310	74-30-01	E19
6310	74-30-01	E20
637847	24-30-01	B15
637847	24-30-01	B15
637847	24-30-02	B15
637847	24-30-02	B15
637847	24-30-03	B15
637847	24-30-03	B15
637847	24-30-04	B15
637847	24-30-04	B15
637847	24-30-04	B15
637847	24-30-04	B15
640030	74-30-01	E19
640030	74-30-01	E20
640789	24-30-01	G18
640789	24-30-01	G18
640789	24-30-02	G18
640789	24-30-02	G18
640789	24-30-02	G18
641668	24-30-01	G18
641668	24-30-01	G18
641668	24-30-02	G18
641668	24-30-02	G18
641668	24-30-03	G18
641668	24-30-03	G18
642055	24-30-04	G18
642056	24-30-03	G18
642056	24-30-03	G18
642056A2	24-30-03	G18
642056A2	24-30-03	G18
642056A2	24-30-03	G18

Part Number	GAMA/ATA Code	Reference Designator
642056A2	24-30-03	G18
642056A2	24-30-04	G18
643808	74-30-02	E20
646490-A1	24-30-04	G18
646490-A1	24-30-04	G18
646490-A1	24-30-04	G18
646490-A1	24-30-04	G18
646491-A1	24-30-04	G18
646491-A1	24-30-04	G18
646491-A1	24-30-04	G18
646491-A1	24-30-04	G18
646491-A1	24-30-04	G18
646845	24-30-04	G18
646981	74-30-02	E19
660101-2	32-30-01	P81B
660101-2	32-30-01	P81B
660101-2	32-31-01	P81B
66017-1	32-30-01	P85B
66017-1	32-30-01	P85B
66017-1	32-30-02	P85B
66017-1	32-30-02	P85B
66017-1	32-31-01	P85B
66017-1	32-31-02	P85B
66017-1	32-60-01	P85B
66017-1	32-60-01	P85B
66017-1	33-45-01	P85B
66017-1	33-45-01	P85B
66099-2	21-50-01	J11C
66099-2	21-50-02	J11C
66099-2	21-50-03	J11C
66099-2	21-50-03	J11C
66099-2	21-50-03	J11C
66099-2	27-31-01	J33C
66099-2	27-31-02	J10D
66099-2	27-31-02	J10D
66099-2	27-50-01	P10D
66099-2	27-51-01	J10D
66099-2	28-40-01	J11C
66099-2	28-40-01	J33B
66099-2	28-40-02	J10D
66099-2	28-40-02	J11C
66099-2	28-40-03	J10D
66099-2	28-40-03	J11C
66099-2	28-40-04	J10D
66099-2	28-40-04	J11C
66099-2	28-40-05	J10D
66099-2	28-40-05	J11C
66099-2	30-30-01	J33C
66099-2	30-30-02	J10D
66099-2	32-30-01	J81B
66099-2	32-30-01	J81B
66099-2	32-31-01	J81B
66099-2	32-60-01	J10D
66099-2	32-60-01	J11C
66099-2	32-60-01	J10D
66099-2	32-60-01	J11C
66099-2	33-45-01	J10D
66099-2	33-45-01	J11C

Raytheon Aircraft

BEECH BONANZA WIRING DIAGRAM MANUAL

PART NUMBER INDEX (CONTINUED)

Part Number	GAMA/ATA Code	Reference Designator
66099-2	33-45-01	J10D
66099-2	33-45-01	J11C
66099-2	91-12-01	J10D
66099-2	91-12-02	J10D
66099-2	91-12-02	J10D
66099-2	91-13-01	J11D
66101-2	21-50-01	P11C
66101-2	21-50-02	P11C
66101-2	21-50-03	P11C
66101-2	21-50-03	P11C
66101-2	21-50-03	P11C
66101-2	21-50-03	P11C
66101-2	27-31-01	P33C
66101-2	27-31-02	P10B
66101-2	27-31-02	P10B
66101-2	27-50-01	J10C
66101-2	27-51-01	P10B
66101-2	28-40-01	P11C
66101-2	28-40-01	P33B
66101-2	28-40-02	P10B
66101-2	28-40-02	P11C
66101-2	28-40-03	P10B
66101-2	28-40-03	P11C
66101-2	28-40-04	P10B
66101-2	28-40-04	P11C
66101-2	28-40-05	P10B
66101-2	28-40-05	P11C
66101-2	30-30-01	P33C
66101-2	30-30-02	P10B
66101-2	32-30-01	P82B
66101-2	32-30-01	P82B
66101-2	32-31-01	P82B
66101-2	32-31-02	P82B
66101-2	32-60-01	P10B
66101-2	32-60-01	P11C
66101-2	32-60-01	P10B
66101-2	32-60-01	P11C
66101-2	33-45-01	P10B
66101-2	33-45-01	P11C
66101-2	33-45-01	P10B
66101-2	33-45-01	P11C
66101-2	91-12-01	P10D
66101-2	91-12-02	P10D
66101-2	91-12-02	P10D
66101-2	91-13-01	P11D
66103-2	21-50-01	J11D
66103-2	21-50-01	J81B
66103-2	21-50-02	J11D
66103-2	21-50-02	J115C
66103-2	21-50-03	J11D
66103-2	21-50-03	J11D
66103-2	21-50-03	J11D
66103-2	21-50-03	J11D
66103-2	24-30-04	J54C
66103-2	24-30-04	J54C
66103-2	24-30-04	J54C
66103-2	24-30-04	J54C
66103-2	27-31-01	J33B

Part Number	GAMA/ATA Code	Reference Designator
66103-2	27-31-02	J10C
66103-2	27-31-02	J54C
66103-2	27-31-02	J10C
66103-2	27-50-01	P10C
66103-2	27-50-02	J44B
66103-2	27-50-02	J44B
66103-2	27-51-01	J10C
66103-2	27-51-02	J44B
66103-2	27-51-02	J54C
66103-2	28-40-01	J11D
66103-2	28-40-01	J33C
66103-2	28-40-02	J10C
66103-2	28-40-02	J11D
66103-2	28-40-03	J10C
66103-2	28-40-03	J11D
66103-2	28-40-04	J10C
66103-2	28-40-04	J11D
66103-2	28-40-05	J10C
66103-2	28-40-05	J11D
66103-2	30-30-01	J33D
66103-2	30-30-02	J10C
66103-2	32-30-01	J54C
66103-2	32-30-01	J82C
66103-2	32-30-01	J54C
66103-2	32-30-01	J56B
66103-2	32-30-01	J82C
66103-2	32-30-02	J115C
66103-2	32-30-02	J54C
66103-2	32-30-02	J82C
66103-2	32-30-02	J115C
66103-2	32-30-02	J54C
66103-2	32-30-02	J82C
66103-2	32-31-01	J54C
66103-2	32-31-01	J82C
66103-2	32-31-02	J115C
66103-2	32-31-02	J54C
66103-2	32-31-02	J56B
66103-2	32-31-02	J82C
66103-2	32-60-01	J10C
66103-2	32-60-01	J11D
66103-2	32-60-01	J54C
66103-2	32-60-01	J10C
66103-2	32-60-01	J11D
66103-2	32-60-01	J54C
66103-2	32-60-01	J56B
66103-2	32-60-02	J54C
66103-2	32-60-02	LS10J1B
66103-2	33-10-01	J54C
66103-2	33-10-02	J54C
66103-2	33-10-02	J54C
66103-2	33-10-02	J54C
66103-2	33-45-01	J10C
66103-2	33-45-01	J11D
66103-2	33-45-01	J10C
66103-2	33-45-01	J11D
66103-2	34-22-01	J54C
66103-2	91-01-02	J54B
66103-2	91-02-01	J54C

Raytheon Aircraft

BEECH BONANZA WIRING DIAGRAM MANUAL

PART NUMBER INDEX (CONTINUED)

Part Number	GAMA/ATA Code	Reference Designator
66103-2	91-02-02	J54C
66103-2	91-12-01	J10C
66103-2	91-12-02	J10C
66103-2	91-12-02	J10C
66103-2	91-13-01	J11C
66103-2	91-19-03	J54B
66103-2	91-19-03	J54B
66105-2	21-50-01	P11D
66105-2	21-50-01	P81C
66105-2	21-50-02	P11D
66105-2	21-50-02	P115C
66105-2	21-50-03	P11D
66105-2	21-50-03	P11D
66105-2	21-50-03	P11D
66105-2	21-50-03	P11D
66105-2	24-30-04	P54C
66105-2	24-30-04	P54C
66105-2	24-30-04	P54C
66105-2	24-30-04	P54C
66105-2	27-31-01	P33D
66105-2	27-31-02	P10C
66105-2	27-31-02	P54C
66105-2	27-31-02	P10C
66105-2	27-50-01	J10D
66105-2	27-50-02	P44B
66105-2	27-50-02	P44B
66105-2	27-51-01	P10C
66105-2	27-51-02	P44B
66105-2	27-51-02	P54C
66105-2	28-40-01	P11D
66105-2	28-40-01	P33C
66105-2	28-40-02	P10C
66105-2	28-40-02	P11D
66105-2	28-40-03	P10C
66105-2	28-40-03	P11D
66105-2	28-40-04	P10C
66105-2	28-40-04	P11D
66105-2	28-40-04	P147B
66105-2	28-40-04	P148B
66105-2	28-40-05	P10C
66105-2	28-40-05	P11D
66105-2	28-40-05	P147B
66105-2	28-40-05	P148B
66105-2	30-30-01	P33D
66105-2	30-30-02	P10C
66105-2	32-30-01	P54C
66105-2	32-30-01	P54C
66105-2	32-30-01	P56B
66105-2	32-30-02	P115C
66105-2	32-30-02	P54C
66105-2	32-30-02	P82C
66105-2	32-30-02	P115C
66105-2	32-30-02	P54C
66105-2	32-30-02	P56B
66105-2	32-30-02	P82C
66105-2	32-31-01	P54C
66105-2	32-31-01	P56B
66105-2	32-31-02	P54C

Part Number	GAMA/ATA Code	Reference Designator
66105-2	32-31-02	P56B
66105-2	32-60-01	P10C
66105-2	32-60-01	P11D
66105-2	32-60-01	P54C
66105-2	32-60-01	P10C
66105-2	32-60-01	P11D
66105-2	32-60-01	P54C
66105-2	32-60-01	P56B
66105-2	32-60-02	P16B
66105-2	32-60-02	P54C
66105-2	33-10-01	P54C
66105-2	33-10-02	P54C
66105-2	33-10-02	P54C
66105-2	33-10-02	P54C
66105-2	33-45-01	P10C
66105-2	33-45-01	P11D
66105-2	33-45-01	P10C
66105-2	33-45-01	P11D
66105-2	34-22-01	P54C
66105-2	91-01-02	P54B
66105-2	91-02-01	P54C
66105-2	91-02-02	P54C
66105-2	91-12-01	P10C
66105-2	91-12-02	P10C
66105-2	91-12-02	P10C
66105-2	91-13-01	P11C
66105-2	91-19-03	P54B
66105-2	91-19-03	P54B
66602-1	32-30-01	J56C
66602-1	32-31-02	J56C
66602-1	32-60-01	J56C
678	33-40-01	DS11C
678	33-40-02	DS11C
678	33-40-02	DS11E
678	33-40-02	DS11E
70-117224-5	24-40-01	K12
701148-7-2	33-40-01	DS12A2
701148-7-2	33-40-01	DS13
701148-7-2	33-40-02	DS12A
701148-7-2	33-40-02	DS13
701148-7-2	33-40-02	DS12A
701148-7-2	33-40-02	DS13
701571	33-40-01	PS11
701571	33-40-02	PS11
701571	33-40-02	PS11
7270-5-10	21-52-01	CB34
7270-5-10	24-50-02	CB34
7270-5-10	24-51-02	CB34
7270-5-10	24-52-02	CB34
7271-8-15	21-50-03	CB33
7271-8-15	21-50-03	CB33
7271-8-15	21-50-03	CB33
7271-8-15	21-50-03	CB33
7271-8-15	24-50-02	CB17
7271-8-15	24-50-02	CB33
7271-8-15	24-50-02	CB17
7271-8-15	24-50-02	CB33
7271-8-15	24-51-02	CB33

Raytheon Aircraft

BEECH BONANZA WIRING DIAGRAM MANUAL

PART NUMBER INDEX (CONTINUED)

Part Number	GAMA/ATA Code	Reference Designator
7271-8-15	24-51-02	CB33
7271-8-15	24-52-01	CB33
7271-8-15	24-52-02	CB33
7271-8-15	24-52-02	CB33
7271-8-30	24-50-02	CB19
7271-8-30	24-50-02	CB19
7277-2-10	24-50-01	CB33
7277-2-10	24-50-02	CB14
7277-2-10	24-50-02	CB31
7277-2-10	24-50-02	CB14
7277-2-10	24-51-02	CB14
7277-2-10	24-51-02	CB14
7277-2-10	24-52-02	CB14
7277-2-10	24-52-02	CB31
7277-2-10	24-52-02	CB14
7277-2-10	24-52-02	CB31
7277-2-10	28-20-03	CB31
7277-2-10	28-20-03	CB31
7277-2-10	28-20-03	CB31
7277-2-10	28-20-04	CB31
7277-2-10	28-20-05	CB31
7277-2-5	24-33-01	CB26
7277-2-5	24-33-01	CB28
7277-2-5	24-33-01	CB30
7277-2-5	24-33-02	CB26
7277-2-5	24-33-02	CB28
7277-2-5	24-33-02	CB30
7277-2-5	24-34-01	CB26
7277-2-5	24-34-01	CB28
7277-2-5	24-34-01	CB30
7277-2-5	24-34-02	CB26
7277-2-5	24-34-02	CB28
7277-2-5	24-34-02	CB30
7277-2-5	24-50-02	CB12
7277-2-5	24-50-02	CB18
7277-2-5	24-50-02	CB21
7277-2-5	24-50-02	CB22
7277-2-5	24-50-02	CB23
7277-2-5	24-50-02	CB24
7277-2-5	24-50-02	CB25
7277-2-5	24-50-02	CB26
7277-2-5	24-50-02	CB27
7277-2-5	24-50-02	CB28
7277-2-5	24-50-02	CB29
7277-2-5	24-50-02	CB30
7277-2-5	24-50-02	CB35
7277-2-5	24-50-02	CB12
7277-2-5	24-50-02	CB16
7277-2-5	24-50-02	CB18
7277-2-5	24-50-02	CB21
7277-2-5	24-50-02	CB22
7277-2-5	24-50-02	CB23
7277-2-5	24-50-02	CB24
7277-2-5	24-50-02	CB25
7277-2-5	24-50-02	CB26
7277-2-5	24-50-02	CB27
7277-2-5	24-50-02	CB28
7277-2-5	24-50-02	CB29
7277-2-5	24-50-02	CB30
7277-2-5	24-50-02	CB35
7277-2-5	24-50-02	CB29
7277-2-5	24-50-02	CB29

Part Number	GAMA/ATA Code	Reference Designator
7277-2-5	24-50-02	CB30
7277-2-5	24-50-02	CB31
7277-2-5	24-50-02	CB35
7277-2-5	24-51-02	CB21
7277-2-5	24-51-02	CB21
7277-2-5	24-52-02	CB12
7277-2-5	24-52-02	CB13
7277-2-5	24-52-02	CB16
7277-2-5	24-52-02	CB18
7277-2-5	24-52-02	CB21
7277-2-5	24-52-02	CB22
7277-2-5	24-52-02	CB23
7277-2-5	24-52-02	CB24
7277-2-5	24-52-02	CB25
7277-2-5	24-52-02	CB26
7277-2-5	24-52-02	CB27
7277-2-5	24-52-02	CB28
7277-2-5	24-52-02	CB29
7277-2-5	24-52-02	CB30
7277-2-5	24-52-02	CB35
7277-2-5	24-52-02	CB12
7277-2-5	24-52-02	CB13
7277-2-5	24-52-02	CB16
7277-2-5	24-52-02	CB18
7277-2-5	24-52-02	CB21
7277-2-5	24-52-02	CB22
7277-2-5	24-52-02	CB23
7277-2-5	24-52-02	CB24
7277-2-5	24-52-02	CB25
7277-2-5	24-52-02	CB26
7277-2-5	24-52-02	CB27
7277-2-5	24-52-02	CB28
7277-2-5	24-52-02	CB29
7277-2-5	24-52-02	CB30
7277-2-5	24-52-02	CB35
7277-2-5	25-10-02	CB14
7277-2-5	25-10-03	CB14
7277-2-5	25-11-01	CB16
7277-2-5	25-11-02	CB16
7277-2-5	25-12-03	CB16
7277-2-5	27-31-02	CB12
7277-2-5	27-31-02	CB12
7277-2-5	27-32-01	CB35
7277-2-5	27-50-02	CB16
7277-2-5	27-50-02	CB16
7277-2-5	27-51-02	CB16
7277-2-5	28-40-03	CB30
7277-2-5	28-40-04	CB30
7277-2-5	28-40-05	CB30
7277-2-5	32-30-01	CB18
7277-2-5	32-30-01	CB18
7277-2-5	32-30-02	CB18
7277-2-5	32-30-02	CB18
7277-2-5	32-31-01	CB13
7277-2-5	32-31-01	CB18
7277-2-5	32-31-02	CB18
7277-2-5	32-60-01	CB29
7277-2-5	32-60-01	CB29

Raytheon Aircraft

BEECH BONANZA WIRING DIAGRAM MANUAL

PART NUMBER INDEX (CONTINUED)

Part Number	GAMA/ATA Code	Reference Designator
7277-2-5	33-10-01	CB23
7277-2-5	33-10-01	CB29
7277-2-5	33-10-02	CB23
7277-2-5	33-10-02	CB29
7277-2-5	33-10-02	CB23
7277-2-5	33-10-02	CB29
7277-2-5	33-10-02	CB23
7277-2-5	33-10-02	CB29
7277-2-5	33-11-02	CB16
7277-2-5	33-11-02	CB16
7277-2-5	33-15-01	CB25
7277-2-5	33-15-01	CB27
7277-2-5	33-15-02	CB25
7277-2-5	33-15-02	CB27
7277-2-5	33-20-02	CB24
7277-2-5	34-20-01	CB22
7277-2-5	36-20-02	CB25
7277-2-5	36-20-02	CB25
7277-2-5	73-30-01	CB21
7277-2-5	74-30-01	CB26
7277-2-5	74-30-02	CB26
7277-2-5	77-20-01	CB28
7277-2-5	91-03-01	CB18
76400-20DY	21-50-03	K16
76400-2004	21-50-03	K16
76575-7	21-50-01	S74
76575-7	21-50-03	S74
76575-7	21-50-03	S74
8410K1	33-42-01	S28
855291SI-A-4-DS-P6	33-10-02	XDS151
855291SI-G-5-DS-P6	33-10-02	XDS121
855291SI-G5STD	32-60-01	XDS145
855291SI-G5STD	32-60-01	XDS146
855291SI-G5STD	32-60-01	XDS147
855291SI-G5STD	32-60-01	XDS145
855291SI-G5STD	32-60-01	XDS146
855291SI-G5STD	32-60-01	XDS147
855291SI-R-2-DS-P6	33-10-02	XDS152
855291SI-R-2-DS-P6	33-10-02	XDS26
855291SI-R-2-DS-P6	33-10-02	XDS45
855291SI-R-2-DS-P6	33-10-02	XDS97
855291SI-R2DS-P6	32-60-01	XDS144
855291SI-R2DS-P6	32-60-01	XDS144
855291SI-2-DS-P6	33-10-02	XDS152
855291SI-2-DS-P6	33-10-02	XDS26
855291SI-2-DS-P6	33-10-02	XDS45
855291SI-2-DS-P6	33-10-02	XDS97
855291SIA4DSP6	33-10-02	XDS151
855291SIR2DS-P6	33-10-01	XDS45
855291SIR2DS-P6	33-10-01	XDS97
855291SIR2DSP6	33-10-02	XDS45
855291SIR2DSP6	33-10-02	XDS97
855291S1R2DSP6	33-10-02	XDS26
8857K44	32-30-01	S38
8857K44	32-30-01	S38
8857K44	32-30-02	S38
8857K44	32-30-02	S38

Part Number	GAMA/ATA Code	Reference Designator
8858K40	33-10-01	S31
8858K82	27-50-02	S52
8858K82	27-50-02	S52
8858K82	33-10-01	S31
8858K82	33-10-02	S31
8858K82	33-10-02	S31
8858K82	33-10-02	S31
90-380007-11	30-60-01	M31
90-380007-11	30-60-01	M31
90-380007-5	30-60-01	M31
90-380007-5	30-60-01	M31
90-380007-7	30-60-01	M31
90-380007-7	30-60-01	M31
90-380007-9	30-60-01	M31
90-380007-9	30-60-01	M31
90-380008-1	30-60-01	R15
90-380008-1	30-60-01	R15
90-380010-3	32-31-01	S35
90-380010-3	32-31-02	S35
90-380010-5	32-31-01	S33
90-380010-5	32-31-02	S33
95-360012-15	24-40-01	W23
9505-08	24-30-01	Y1F
9505-08	24-30-02	Y1F
9505-08	24-30-03	Y1F
9505-08	24-30-04	Y1F
96-364078-7	33-44-02	AB
96-364078-7	33-44-02	AB
96-364078-7	33-44-02	AB
96-364090-11	33-11-01	XDS17
96-364090-11	33-11-02	XDS17
96-364090-11	33-11-02	XDS17
96-380022-5	32-30-01	B21
96-380022-5	32-31-01	B21
96-380041-1	28-40-01	R20
96-380041-1	28-40-01	R22
96-380041-1	28-40-02	R20
96-380041-1	28-40-02	R22
96-380041-1	28-40-03	R20
96-380041-1	28-40-03	R22
96-380041-1	28-40-04	R20
96-380041-1	28-40-04	R22
96-380041-1	28-40-05	R20
96-380041-1	28-40-05	R22
96-380042-1	28-40-01	R21
96-380042-1	28-40-02	R21
96-380042-1	28-40-03	R21
96-380042-1	28-40-04	R21
96-380042-1	28-40-05	R21
96-380042-3	28-40-01	R23
96-380042-3	28-40-02	R23
96-380042-3	28-40-03	R23
96-380042-3	28-40-04	R23
96-380042-3	28-40-05	R23
96-384050-7	32-31-01	S30B
96-384050-7	32-31-02	S30B

CHAPTER

21

**AIR
CONDITIONING**

Raytheon Aircraft

BEECH BONANZA WIRING DIAGRAM MANUAL

LIST OF PAGES & TABLE OF CONTENTS
for
CHAPTER 21 - ENVIRONMENTAL SYSTEMS

SYS/SUB-SYS/ CHAP SECTION	PAGE NO.	EFFECTIVE DATE	TABLE OF CONTENTS
21-50-01	Page 1 Page 2 Page 3	Oct/95 Oct/95 01/29/99	AIR CONDITIONING - COOLING (OPTIONAL) E-1111, E-1241 THRU E-1808; CE-748, CE-772 THRU CE-940; D-10097, D-10120 THRU D-10363
21-50-02	Page 1 Page 2 Page 3	Oct/95 Oct/95 01/29/99	AIR CONDITIONING - COOLING (OPTIONAL) E-1809 THRU E-1910; CE-941 THRU CE-968; D-10348, D-10364 THRU D-10379
21-50-03 (Config 1)	Page 1 Page 2 Page 3	Oct/95 Oct/95 01/29/99	AIR CONDITIONING - COOLING (OPTIONAL) E-1911 THRU E-1945, E-1947 THRU E-2103, E-2105 THRU E-2110; CE-969 THRU CE-1036; D-10380 AND AFTER; EA-356 THRU EA-388
21-50-03 (Config 2)	Page 1 Page 2 Page 3	01/29/99 01/29/99 01/29/99	AIR CONDITIONING - COOLING (OPTIONAL) CE-1037 THRU CE-1456 (WITHOUT KIT 36-3015-1 INSTALLED)
21-50-03 (Config 3)	Page 1 Page 2 Page 3	01/29/99 01/29/99 01/29/99	AIR CONDITIONING - COOLING (OPTIONAL) CE-1037 THRU CE-1456 (WITH KIT 36-3015-1 INSTALLED)
21-50-03 (Config 4)	Page 1 Page 2 Page 3	01/29/99 01/29/99 01/29/99	AIR CONDITIONING - COOLING (OPTIONAL) CE-1457 AND AFTER
21-52-01 (Config 1)	Page 1 Page 2 Page 3	Oct/95 Oct/95 Oct/95	BLOWER - FRESH AIR VENT (OPTIONAL) E-1809 THRU E-1945, E-1947 THRU E-2070; CE-941 THRU CE-1017; D-10348, D-10364 THRU D-10403; EA-192 THRU EA-319, EA-321 THRU EA-349
21-52-01 (Config 2)	Page 1 Page 2 Page 3	Oct/95 Oct/95 Oct/95	BLOWER - FRESH AIR VENT (OPTIONAL) E-2071 THRU E-2103, E-2105 THRU E-2110; CE-1018 AND AFTER; CJ-156 AND AFTER; D-10404 AND AFTER; EA-350 THRU EA-388

Beechcraft
BONANZA
WIRING DIAGRAM MANUAL

21-50-01

**E-1111, E-1241 THRU E-1808; CE-748, CE-772 THRU CE-940; D-10097,
D-10120 THRU D-10363**

Beechcraft BONANZA WIRING DIAGRAM MANUAL

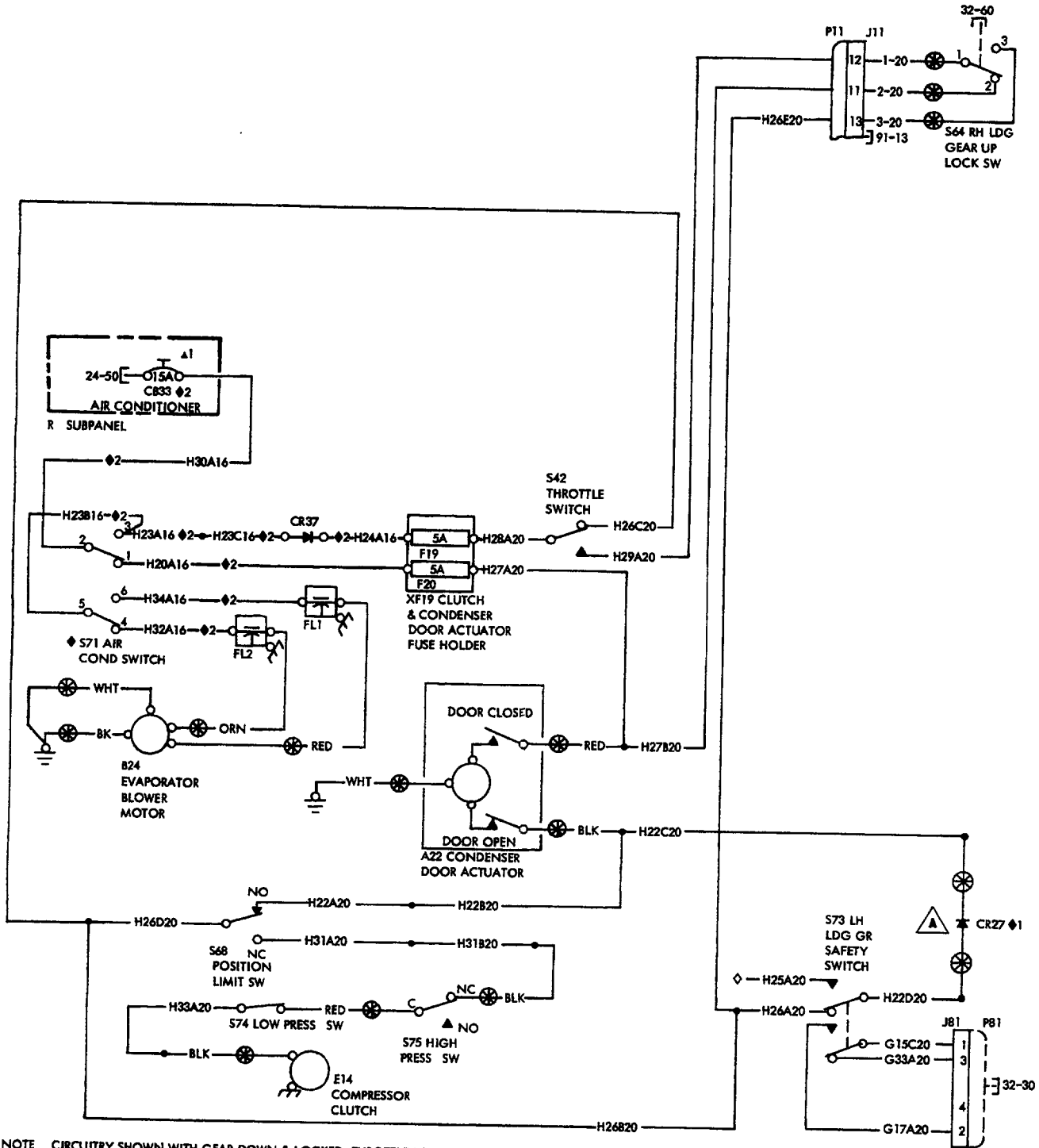

NOTE CIRCUITRY SHOWN WITH GEAR DOWN & LOCKED THROTTLE BACK AND AIR CONDITIONER OFF

- ◇ CAP AND STOW
- ◆ S71 THREE - POSITION SWITCH CODE
- OFF 2-1 5-4
- HIGH 2-3, 5-4
- LOW 2-3 5-6

- ◆1 ON ACFT E-1591 & AFT, CE-883 & AFT, & D-10300 & AFT, DIODE CR27 IS USED PRIOR TO THESE EFF WIRES H22C20 & H22D20 SPLICED TOGETHER
- ◆2 PRIOR TO E-1650, CE-898 & D-10337, CB33 WAS 10A & ALL WIRES OF S71 AC SWITCH & CR37 DIODE WIRE 18 GAGE
- ▲ AIRPLANES PRIOR TO E-1591, CE-883 & D-10300 WHICH ARE IN COMPLIANCE WITH S.I. 1099 HAVE DIODE CR27.

AIR CONDITIONING-COOLING (OPTIONAL)

Raytheon Aircraft

BEECH BONANZA WIRING DIAGRAM MANUAL

REFERENCE DESIGNATOR	PART NUMBER	DESCRIPTION	INSTL ZONE	USABLE ON CODE
21-50-01				
A22	36-380021-27	ACTUATOR-CONDENSER DOOR	150	1
B24	36-380027-29	MOTOR-EVAPORATOR BLOWER (OPTL)	140	1
CB33	435-210-104	CIRCUIT BREAKER-AIR CONDITIONER (OPTL)	240	2
CB33	435-215-104	CIRCUIT BREAKER-AIR CONDITIONER (OPTL)	240	3
CB33	MS24510-15	CIRCUIT BREAKER-AIR CONDITIONER (OPTL)	240	4
CR27	1N5404	DIODE-CONDENSER ACTUATOR	730	5
CR37	1N1199A	DIODE-AIR CONDITIONER (SUPERSEDED BY 132408-9)	222	1
CR37	132408-9	DIODE-AIR CONDITIONER (SUPERSEDES 1N1199A)	222	1
E14	102-389006-9	CLUTCH-COMPRESSOR	410	1
FL1	A1437	FILTER-AIR CONDITIONER (OPTL)	140	1
FL2	A1437	FILTER-AIR CONDITIONER (OPTL)	140	1
F19	AGC5	FUSE-AIR CONDITIONER (OPTL)	222	1
F20	AGC5	FUSE-AIR CONDITIONER (OPTL)	222	1
J11A	206036-3	RECEPTACLE-WHEEL WELL ACCESS, RIGHT	632	1
J11B	206070-1	STRAIN RELIEF	632	1
J11C	66099-2	PIN CONTACT	632	1
J11D	66103-2	PIN CONTACT	632	1
J81A	206153-1	RECEPTACLE-LANDING GEAR SAFETY SWITCH, LEFT	532	1
J81B	66103-2	PIN CONTACT	532	1
J81C	206062-1	STRAIN RELIEF	532	1
P11A	206037-1	PLUG-WHEEL WELL ACCESS, RIGHT	632	1
P11B	206070-1	STRAIN RELIEF	632	1
P11C	66101-2	SOCKET CONTACT	632	1
P11D	66105-2	SOCKET CONTACT	632	1
P81A	206060-1	PLUG-LANDING GEAR SAFETY SWITCH, LEFT	532	1
P81B	206062-1	STRAIN RELIEF	532	1
P81C	66105-2	SOCKET CONTACT	532	1
S42	V3-1	SWITCH-THROTTLE, AIR CONDITIONER	410	1
S64	100-381006-1	SWITCH-LANDING GEAR UP LIMIT, RIGHT	740	1
S68	MS25026-1	SWITCH-CONDENSER POSITION LIMIT (OPTL)	150	1
S71	MS27407-1	SWITCH-AIR CONDITIONER (OPTL)	240	1
S73A	002-361013-47	SWITCH ASSEMBLY-LANDING GEAR SAFETY, LEFT	730	5
S73B	MS25008-1	SWITCH-LANDING GEAR SAFETY, LEFT	730	5
S73C	MCD2711	ACTUATOR-LANDING GEAR SAFETY SWITCH	730	5
S74	76575-7	SWITCH-LOW PRESSURE (SUPERSEDES M4006-7 AND M4008-7)	140	1
S75	101-380002-3	SWITCH-HIGH PRESSURE (OPTL)	140	1
XF19	4532	FUSE HOLDER-CLUTCH AND CONDENSER, DOOR ACTUATOR	222	1

CODES OF EFFECTIVITY

1. E-1111, E-1241 THRU E-1808; CE-748, CE-772 THRU CE-940; D-10097, D-10120 THRU D-10363
2. E-1111, E-1241 THRU E-1808; CE-748, CE-772 THRU CE-897; D-10097, D-10120 THRU D-10336
3. CE-898 THRU CE-918, CE-920 THRU CE-928; D-10337 THRU D-10353
4. CE-919, CE-929 THRU CE-940; D-10354 THRU D-10363
5. E-1591 THRU E-1808; CE-883 THRU CE-940; D-10300 THRU D-10363

Beechcraft
BONANZA
WIRING DIAGRAM MANUAL

21-50-02

**E-1809 THRU E-1910; CE-941 THRU CE-968; D-10348, D-10364 THRU
D-10379**

Beechcraft BONANZA WIRING DIAGRAM MANUAL

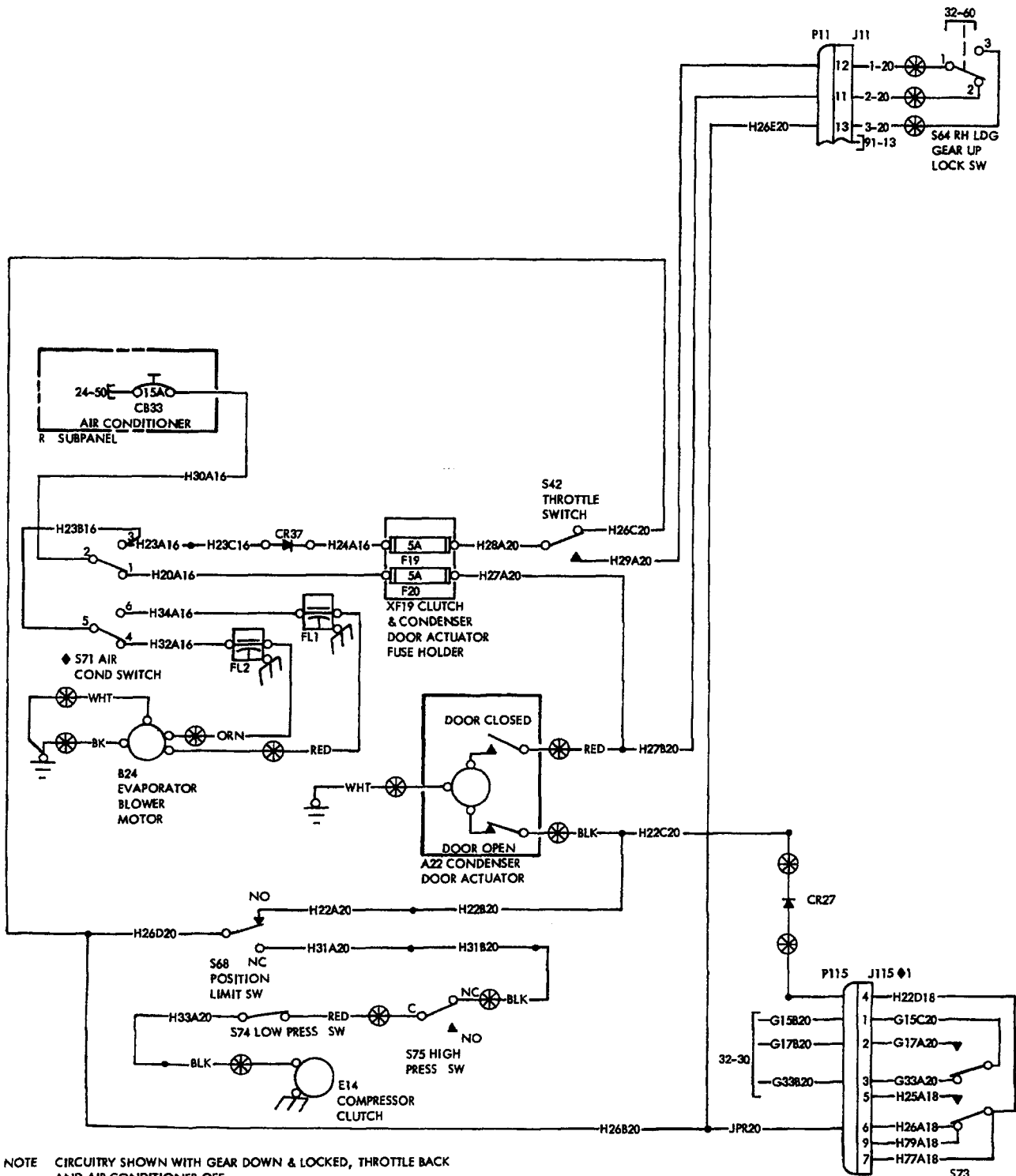

NOTE CIRCUITRY SHOWN WITH GEAR DOWN & LOCKED, THROTTLE BACK AND AIR CONDITIONER OFF

- ◇ CAP AND STOW
- ◆ S71 THREE - POSITION SWITCH CODE
- OFF 2-1 5-4
- HIGH 2-3, 5-4
- LOW 2-3, 5-6

◆1 WHEN AIR CONDITIONING OPTION IS CALLED OUT S73 REPLACES S37, P/J115 REPLACES P/J81 (REF DIAG 32-30) AND ARE WIRED AS SHOWN

S73
◆1 L LANDING GEAR SAFETY SW

AIR CONDITIONING-COOLING (OPTIONAL)

Raytheon Aircraft

BEECH BONANZA WIRING DIAGRAM MANUAL

REFERENCE DESIGNATOR	PART NUMBER	DESCRIPTION	INSTL ZONE	USABLE ON CODE
21-50-02				
A22	36-380021-27	ACTUATOR-CONDENSER DOOR	150	1
B24	36-380027-29	MOTOR-EVAPORATOR BLOWER (OPTL)	140	1
CB33	435-215-104	CIRCUIT BREAKER-AIR CONDITIONER (OPTL)	240	3
CB33	7271-8-15	CIRCUIT BREAKER-AIR CONDITIONER (OPTL)	240	2
CR27	1N5404	DIODE-CONDENSER ACTUATOR	730	1
CR37	1N1199A	DIODE-AIR CONDITIONER (OPTL) (SUPERSEDED BY 132408-9)	222	1
CR37	132408-9	DIODE-AIR CONDITIONER (OPTL) (SUPERSEDES 1N1199A)	222	1
E14	102-389006-9	CLUTCH-COMPRESSOR	410	1
FL1	A1437	FILTER-AIR CONDITIONER (OPTL)	140	1
FL2	A1437	FILTER-AIR CONDITIONER (OPTL)	140	1
F19	AGC5	FUSE-AIR CONDITIONER (OPTL)	222	1
F20	AGC5	FUSE-AIR CONDITIONER (OPTL)	222	1
J11A	206036-3	RECEPTACLE-WHEEL WELL ACCESS, RIGHT	632	1
J11B	206070-1	STRAIN RELIEF	632	1
J11C	66099-2	PIN CONTACT	632	1
J11D	66103-2	PIN CONTACT	632	1
J115A	206705-2	RECEPTACLE-LDG GEAR SAFETY SWITCH, LEFT (OPTL)	532	1
J115B	206966-1	CABLE CLAMP (OPTL)	532	1
J115C	66103-2	PIN CONTACT (OPTL)	532	1
P11A	206037-1	PLUG-WHEEL WELL ACCESS, RIGHT	632	1
P11B	206070-1	STRAIN RELIEF	632	1
P11C	66101-2	SOCKET CONTACT	632	1
P11D	66105-2	SOCKET CONTACT	632	1
P115A	206708-1	PLUG-LANDING GEAR SAFETY SWITCH, LEFT (OPTL)	550	1
P115B	206966-1	CABLE CLAMP (OPTL)	550	1
P115C	66105-2	SOCKET (OPTL)	550	1
S42	V3-1	SWITCH-THROTTLE, AIR CONDITIONER	410	1
S64	100-381006-1	SWITCH-LANDING GEAR UP LIMIT, RIGHT	740	1
S68	MS25026-1	SWITCH-CONDENSER POSITION LIMIT (OPTL)	150	1
S71	MS27407-1	SWITCH-AIR CONDITIONER (OPTL)	240	1
S73A	002-361013-47	SWITCH ASSEMBLY-LANDING GEAR SAFETY, LEFT	730	1
S73B	MS25008-1	SWITCH-LANDING GEAR SAFETY, LEFT	730	1
S73C	MCD2711	ACTUATOR-LANDING GEAR SAFETY SWITCH	730	1
S74	M4008-7	SWITCH-LOW PRESSURE	140	1
S75	101-380002-3	SWITCH-HIGH PRESSURE (OPTL)	140	1
XF19	4532	FUSE HOLDER-CLUTCH AND CONDENSER, DOOR ACT- UATOR	222	1

CODES OF EFFECTIVITY

1. E-1809 THRU E-1910; CE-941 THRU CE-968; D-10348, D-10364 THRU D-10379
2. D-10364 THRU D-10379; CE-941 THRU CE-968; E-1809 THRU E-1910
3. D-10348 ONLY

Beechcraft
BONANZA
WIRING DIAGRAM MANUAL

21-50-03

Configuration 1

**E-1911 THRU E-1945, E-1947 THRU E-2103, E-2105 THRU E-2110;
CE-969 THRU CE-1036; D-10380 AND AFTER; EA-356 THRU EA-388**

Beechcraft BONANZA WIRING DIAGRAM MANUAL

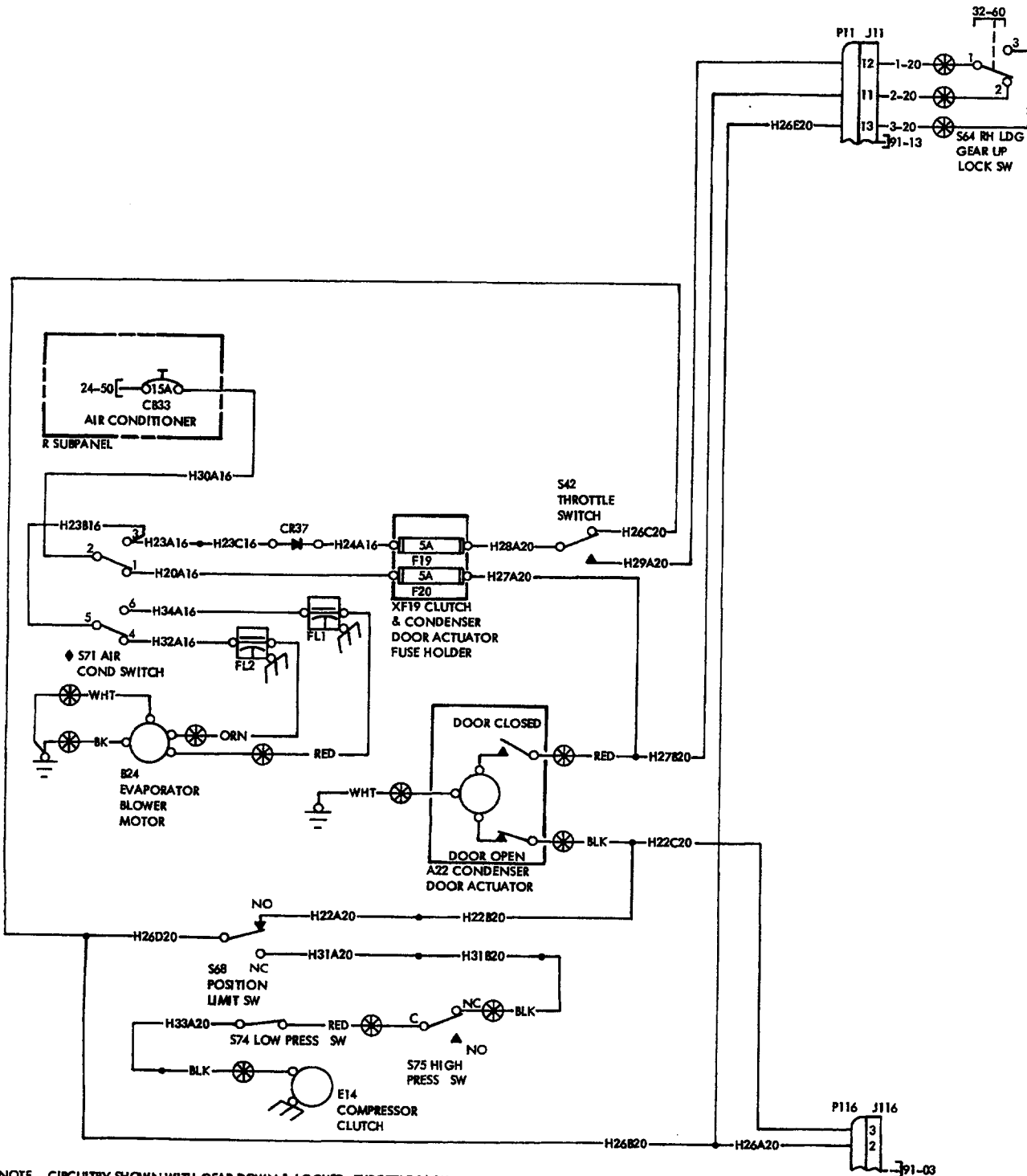

NOTE CIRCUITRY SHOWN WITH GEAR DOWN & LOCKED THROTTLE BACK AND AIR CONDITIONER OFF

- ◆ S71 THREE - POSITION SWITCH CODE
- OFF 2-1, 5-4
- HIGH 2-3, 5-4
- LOW 2-3, 5-6

AIR CONDITIONING-COOLING (OPTIONAL) (Configuration 1)

Raytheon Aircraft

BEECH BONANZA WIRING DIAGRAM MANUAL

REFERENCE DESIGNATOR	PART NUMBER	DESCRIPTION	INSTL ZONE	USABLE ON CODE
21-50-03				
(Configuration 1)				
A22	36-380021-27	ACTUATOR-CONDENSER DOOR	150	1
B24	36-380027-29	MOTOR-EVAPORATOR BLOWER (OPTL)	140	1
CB33	7271-8-15	CIRCUIT BREAKER-AIR CONDITIONER (OPTL)	240	2
CR37	1N1199A	DIODE (OPTL) (SUPERSEDED BY 132408-9)	222	1
CR37	132408-9	DIODE (OPTL) (SUPERSEDES 1N1199A)	222	1
E14	102-389006-9	CLUTCH-COMPRESSOR	410	1
FL1	A1437	FILTER-AIR CONDITIONER (OPTL)	140	1
FL2	A1437	FILTER-AIR CONDITIONER (OPTL)	140	1
F19	AGC5	FUSE-AIR CONDITIONER (OPTL)	222	1
F20	AGC5	FUSE-AIR CONDITIONER (OPTL)	222	1
J11A	206036-3	RECEPTACLE-WHEEL WELL ACCESS, RIGHT	632	1
J11B	206070-1	STRAIN RELIEF	632	1
J11C	66099-2	PIN CONTACT	632	1
J11D	66103-2	PIN CONTACT	632	1
J116	207443-1	RECEPTACLE-LANDING GEAR SAFETY SWITCH RELAY ASSEMBLY	251	1
P11A	206037-1	PLUG-WHEEL WELL ACCESS, RIGHT	632	1
P11B	206070-1	STRAIN RELIEF	632	1
P11C	66101-2	SOCKET CONTACT	632	1
P11D	66105-2	SOCKET CONTACT	632	1
P116	207442-1	PLUG-LANDING GEAR SAFETY SWITCH RELAY ASSEMBLY	251	1
S42	V3-1	SWITCH-AIR CONDITIONER THROTTLE	410	1
S64	100-381006-1	SWITCH-LANDING GEAR UP LIMIT, RIGHT	740	1
S68	MS25026-1	SWITCH-CONDENSER DOOR/POSITION LIGHT (OPTL)	150	1
S71	MS27407-1	SWITCH-AIR CONDITIONER (OPTL)	240	1
S74	M4008-7	SWITCH-LOW PRESSURE	140	1
S75	101-380002-3	SWITCH-HIGH PRESSURE (OPTL)	140	1
XF19	4532	FUSEHOLDER (OPTL)	222	1

CODES OF EFFECTIVITY

1. E-1911 THRU E-1945, E-1947 THRU E-2103, E-2105 THRU E-2110; CE-969 THRU CE-1036; D-10380 AND AFTER; EA-356 THRU EA-388
2. E-1911 THRU E-1945, E-1947 THRU E-2103, E-2105 THRU E-2110; CE-969 THRU CE-1036; D-10380 AND AFTER

Raytheon Aircraft

BEECH BONANZA WIRING DIAGRAM MANUAL

21-50-03

AIR CONDITIONING - COOLING (OPTIONAL)

(Configuration 2)

CE-1037 THRU CE-1456 (WITHOUT KIT 36-3015-1 INSTALLED)

Raytheon Aircraft

BEECH BONANZA WIRING DIAGRAM MANUAL

NOTE CIRCUITRY SHOWN WITH GEAR DOWN & LOCKED
THROTTLE BACK AND AIR CONDITIONER OFF

◆ S71 THREE-POSITION SWITCH CODE

OFF 2-1, 5-4
HIGH 2-3, 5-4
LOW 2-3, 5-6

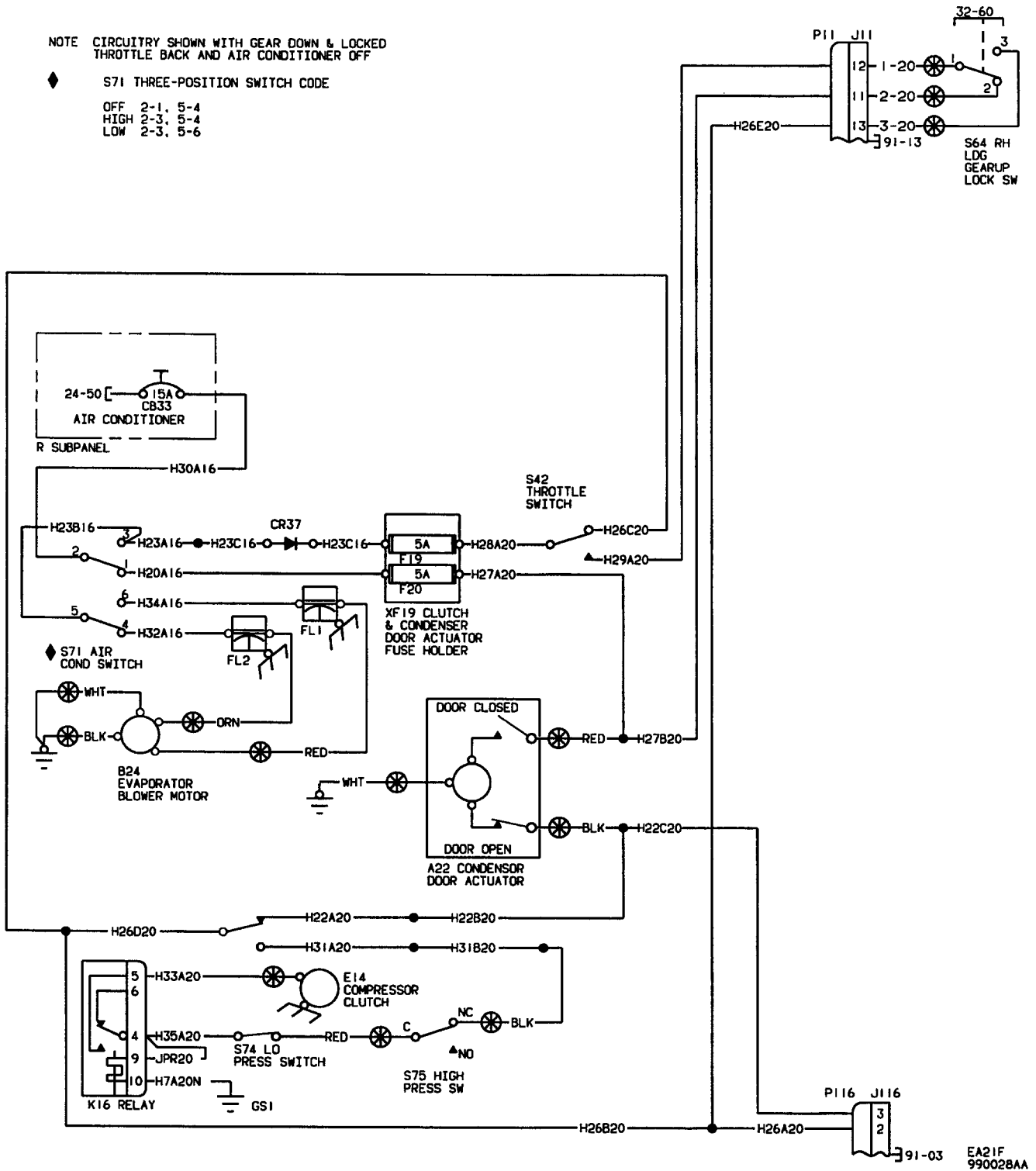

AIR CONDITIONING - COOLING (OPTIONAL) CE-1037 THRU CE-1456 (WITHOUT KIT 36-3015-1 INSTALLED) (Configuration 2)

Raytheon Aircraft

BEECH BONANZA WIRING DIAGRAM MANUAL

REFERENCE DESIGNATOR	PART NUMBER	DESCRIPTION	INSTL ZONE	USABLE ON CODE
21-50-03				
(Configuration 2)				
A22	36-380021-27	ACTUATOR - CONDENSER DOOR	150	1
B24	36-380027-29	MOTOR - EVAPORATOR BLOWER (OPTL)	140	1
CB33	7271-8-15	CIRCUIT BREAKER - AIR CONDITIONER (OPTL)	240	1
CR37	1N1199A	DIODE (OPTL) (SUPERSEDED BY 132408-9)	222	1
CR37	132408-9	DIODE (OPTL) (SUPERSEDES 1N1199A)	222	1
E14	102-389006-9	CLUTCH - COMPRESSOR (OPTL)	410	1
FL1	A1437	FILTER - AIR CONDITIONER (OPTL)	140	1
FL2	A1437	FILTER - AIR CONDITIONER (OPTL)	140	1
F19	AGC5	FUSE - AIR CONDITIONER (OPTL)	222	1
F20	AGC5	FUSE - AIR CONDITIONER (OPTL)	222	1
GS1	131270-3	GROUND STUD - MAIN SPAR	270	1
J11A	206036-3	RECEPTACLE - WHEEL WELL ACCESS, RIGHT	632	1
J11B	206070-1	STRAIN RELIEF	632	1
J11C	66099-2	PIN CONTACT	632	1
J11D	66103-2	PIN CONTACT	632	1
J116	207443-1	RECEPTACLE - LDG GEAR SAFETY SWITCH RELAY ASSY	251	1
K16	TNR11720	RELAY - TIME DELAY (SUPERSEDED BY TNR/D11720S)	270	1
K16	TNR/D11720S	RELAY - TIME DELAY (SUPERSEDES TNR11720)	270	1
P11A	206037-1	PLUG - WHEEL WELL ACCESS, RIGHT	632	1
P11B	206070-1	STRAIN RELIEF	632	1
P11C	66101-2	SOCKET CONTACT	632	1
P11D	66105-2	SOCKET CONTACT	632	1
P116	207442-1	PLUG - LANDING GEAR SAFETY SWITCH RELAY ASSEMBLY	251	1
S42	V3-1	SWITCH - AIR CONDITIONER THROTTLE	410	1
S64	100-381006-1	SWITCH - LANDING GEAR UP LIMIT, RIGHT	740	1
S68	MS25026-1	SWITCH - CONDENSER DOOR/POSITION LIGHT (OPTL)	150	1
S71	MS27407-1	SWITCH - AIR CONDITIONER (OPTL)	240	1
S74	M4008-7	SWITCH - LOW PRESSURE	140	1
S75	101-380002-3	SWITCH - HIGH PRESSURE (OPTL)	140	1
XF19	4532	FUSEHOLDER (OPTL)	222	1

CODES OF EFFECTIVITY

1. CE-1037 THRU CE-1456 (WITHOUT KIT 36-3015-1 INSTALLED)

Raytheon Aircraft

BEECH BONANZA WIRING DIAGRAM MANUAL

21-50-03

AIR CONDITIONING - COOLING (OPTIONAL)

(Configuration 3)

CE-1037 THRU CE-1456 (WITH KIT 36-3015-1 INSTALLED)

Raytheon Aircraft

BEECH BONANZA WIRING DIAGRAM MANUAL

REFERENCE DESIGNATOR	PART NUMBER	DESCRIPTION	INSTL ZONE	USABLE ON CODE
21-50-03				
(Configuration 3)				
A22	36-380021-27	ACTUATOR - CONDENSER DOOR	150	1
B24	36-380027-29	MOTOR - EVAPORATOR BLOWER (OPTL)	140	1
CB33	7271-8-15	CIRCUIT BREAKER - AIR CONDITIONER (OPTL)	240	1
CR37	1N1199A	DIODE (OPTL) (SUPERSEDED BY 132408-9)	222	1
CR37	132408-9	DIODE (OPTL) (SUPERSEDES 1N1199A)	222	1
E14	102-389006-9	CLUTCH - COMPRESSOR (OPTL)	410	1
FL1	A1437	FILTER - AIR CONDITIONER (OPTL)	140	1
FL2	A1437	FILTER - AIR CONDITIONER (OPTL)	140	1
F19	AGC5	FUSE - AIR CONDITIONER (OPTL)	222	1
F20	AGC5	FUSE - AIR CONDITIONER (OPTL)	222	1
GS1	131270-3	GROUND STUD - MAIN SPAR	270	1
J11A	206036-3	RECEPTACLE - WHEEL WELL ACCESS, RIGHT	632	1
J11B	206070-1	STRAIN RELIEF	632	1
J11C	66099-2	PIN CONTACT	632	1
J11D	66103-2	PIN CONTACT	632	1
J116	207443-1	RECEPTACLE - LANDING GEAR SAFETY SWITCH RELAY ASSEMBLY	251	1
K16A	36-3015-1	KIT - AIR CONDITIONING TIME DELAY RELAY	270	1
K16B	76400-20DY	RELAY - TIME DELAY	270	1
P11A	206037-1	PLUG - WHEEL WELL ACCESS, RIGHT	632	1
P11B	206070-1	STRAIN RELIEF	632	1
P11C	66101-2	SOCKET CONTACT	632	1
P11D	66105-2	SOCKET CONTACT	632	1
P116	207442-1	PLUG - LANDING GEAR SAFETY SWITCH RELAY ASSEMBLY	251	1
S42	V3-1	SWITCH - AIR CONDITIONER THROTTLE	410	1
S64	100-381006-1	SWITCH - LANDING GEAR UP LIMIT, RIGHT	740	1
S68	MS25026-1	SWITCH - CONDENSER DOOR/POSITION LIGHT (OPTL)	150	1
S71	MS27407-1	SWITCH - AIR CONDITIONER (OPTL)	240	1
S74	76575-7	SWITCH - LOW PRESSURE (SUPERSEDES M4006-7 AND M4008-7)	140	2
S75	101-380002-3	SWITCH - HIGH PRESSURE (OPTL)	140	1
XF19	4532	FUSEHOLDER (OPTL)	222	1

CODES OF EFFECTIVITY

1. CE-1037 THRU CE-1456 (WITH KIT 36-3015-1 INSTALLED)
2. CE-1301, CE-1307 THRU CE-1456 (WITH KIT 36-3015-1 INSTALLED)

Raytheon Aircraft

BEECH BONANZA WIRING DIAGRAM MANUAL

21-50-03

AIR CONDITIONING - COOLING (OPTIONAL)

**(Configuration 4)
CE-1457 AND AFTER**

Raytheon Aircraft

BEECH BONANZA WIRING DIAGRAM MANUAL

NOTE CIRCUITRY SHOWN WITH GEAR DOWN & LOCKED
THROTTLE BACK AND AIR CONDITIONER OFF

◆ S71 THREE-POSITION SWITCH CODE

OFF 2-1, 5-4
HIGH 2-3, 5-4
LOW 2-3, 5-6

◆ I CAP & STOW

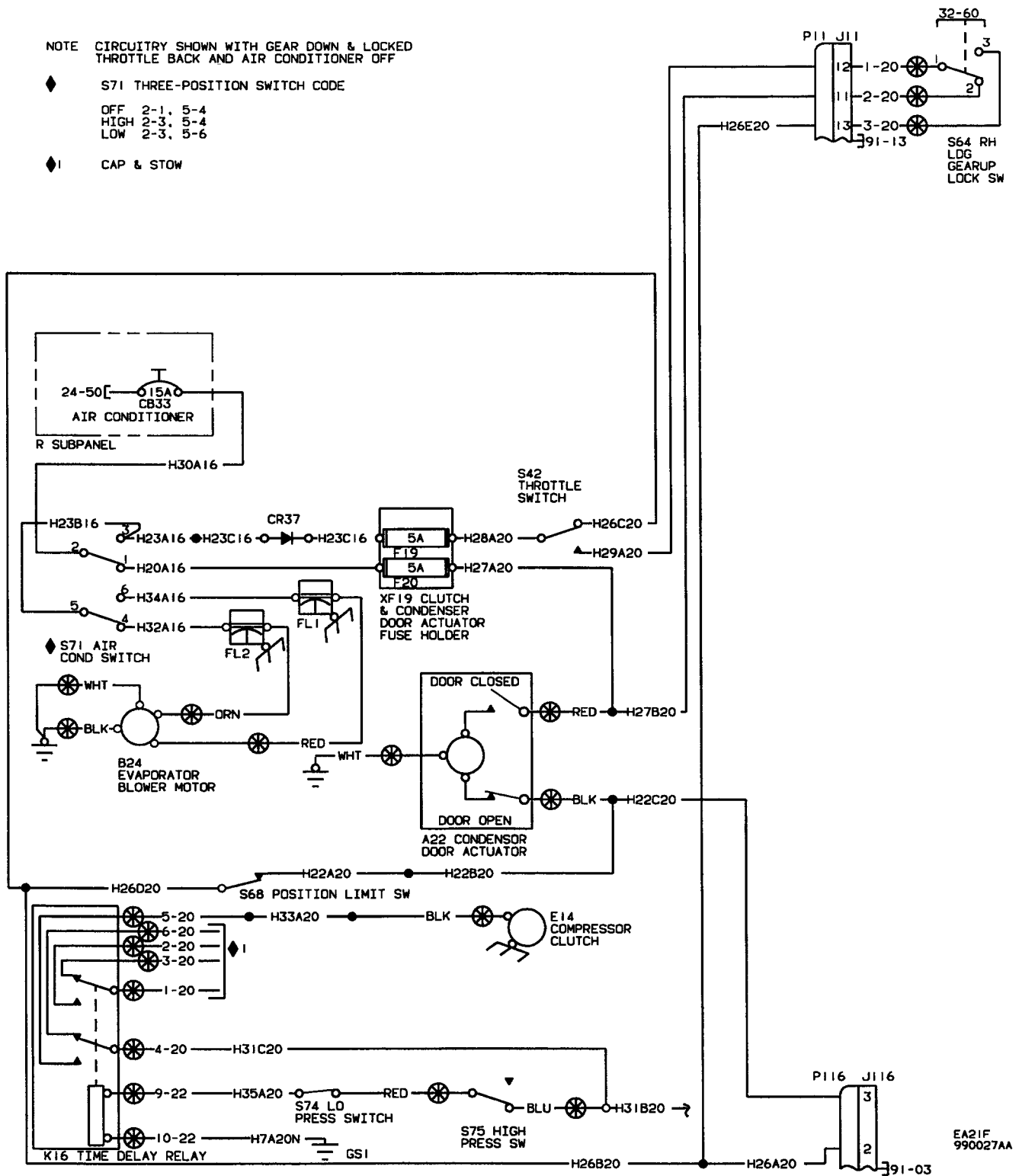

AIR CONDITIONING - COOLING (OPTIONAL)
CE-1457 AND AFTER
(Configuration 4)

Raytheon Aircraft

BEECH BONANZA WIRING DIAGRAM MANUAL

REFERENCE DESIGNATOR	PART NUMBER	DESCRIPTION	INSTL ZONE	USABLE ON CODE
21-50-03				
(Configuration 4)				
A22	36-380021-33	ACTUATOR0 - CONDENSER DOOR (OPTL)	150	3
A22	36-380021-27	ACTUATOR - CONDENSER DOOR	150	2
B24	36-380027-37	MOTOR - EVAPORATOR BLOWER (OPTL)	140	5
B24	36-380027-29	MOTOR - EVAPORATOR BLOWER (OPTL)	140	4
CB33	7271-8-15	CIRCUIT BREAKER - AIR CONDITIONER (OPTL)	240	1
CR37	1N1199A	DIODE (OPTL) (SUPERSEDED BY 132408-9)	222	1
CR37	132408-9	DIODE (OPTL) (SUPERSEDES 1N1199A)	222	1
E14	102-389006-9	CLUTCH - COMPRESSOR (OPTL)	410	1
FL1	A1437	FILTER - AIR CONDITIONER (OPTL)	140	1
FL2	A1437	FILTER - AIR CONDITIONER (OPTL)	140	1
F19	AGC5	FUSE - AIR CONDITIONER (OPTL)	222	1
F20	AGC5	FUSE - AIR CONDITIONER (OPTL)	222	1
GS1	131270-3	GROUND STUD - MAIN SPAR	270	1
J11A	206036-3	RECEPTACLE - WHEEL WELL ACCESS, RIGHT	632	1
J11B	206070-1	STRAIN RELIEF	632	1
J11C	66099-2	PIN CONTACT	632	1
J11D	66103-2	PIN CONTACT	632	1
J116	207443-1	RECEPTACLE - LANDING GEAR SAFETY SWITCH RELAY ASSEMBLY	251	1
K16	76400-2004	RELAY - TIME DELAY	270	1
P11A	206037-1	PLUG - WHEEL WELL ACCESS, RIGHT	632	1
P11B	206070-1	STRAIN RELIEF	632	1
P11C	66101-2	SOCKET CONTACT	632	1
P11D	66105-2	SOCKET CONTACT	632	1
P116	207442-1	PLUG - LANDING GEAR SAFETY SWITCH RELAY ASSEMBLY	251	1
S42	V3-1	SWITCH - AIR CONDITIONER THROTTLE	410	1
S64	100-381006-1	SWITCH - LANDING GEAR UP LIMIT, RIGHT	740	1
S68	MS25026-1	SWITCH - CONDENSER DOOR/POSITION LIGHT (OPTL)	150	1
S71	MS27407-1	SWITCH - AIR CONDITIONER (OPTL)	240	1
S74	76575-7	SWITCH - LOW PRESSURE (SUPERSEDES M4006-7 AND M4008-7)	140	1
S75	101-380002-3	SWITCH - HIGH PRESSURE (OPTL)	140	1
XF19	4532	FUSEHOLDER (OPTL)	222	1

CODES OF EFFECTIVITY

1. CE-1457 AND AFTER
2. CE-1457 THRU CE-1762
3. CE-1763 AND AFTER
4. CE-1457 THRU CE-1766
5. CE-1767 AND AFTER

Beechcraft
BONANZA
WIRING DIAGRAM MANUAL

21-52-01

Configuration 1

**E-1809 THRU E-1945, E-1947 THRU E-2070; CE-941 THRU CE-1017;
D-10348, D-10364 THRU D-10403; EA-192 THRU EA-319, EA-321 THRU
EA-349**

Beechcraft
BONANZA
WIRING DIAGRAM MANUAL

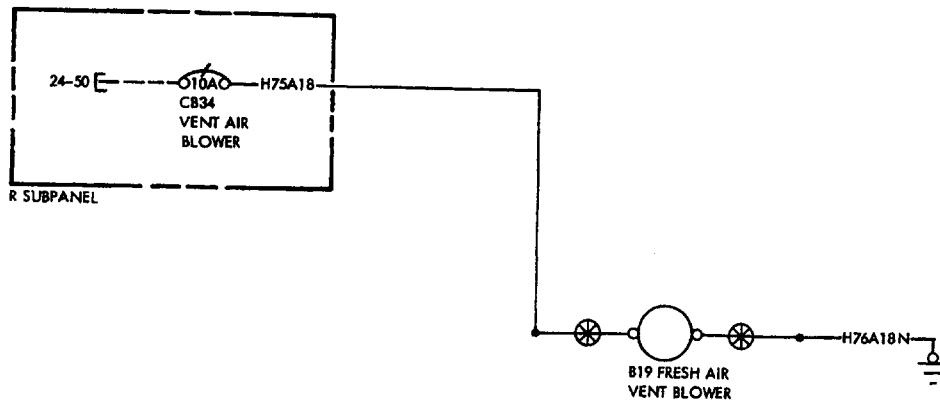

BLOWER-FRESH AIR VENT (OPTIONAL)
(Configuration 1)

Beechcraft
BONANZA
WIRING DIAGRAM MANUAL

REFERENCE DESIGNATOR	PART NUMBER	DESCRIPTION	USABLE	
			INSTL	ON
			ZONE	CODE
21-52-01 (Configuration 1)				
B19	169-380096-5	BLOWER-FRESH AIR VENT (OPTL)	310	1
CB34	7270-5-10	CIRCUIT BREAKER-VENT AIR BLOWER (OPTL)	240	2
CB34	35-380132-33	CIRCUIT BREAKER-VENT AIR BLOWER (OPTL)	240	3

EFFECTIVITY CODE

1. E-1809 THRU E-1945, E-1947 THRU E-2070; CE-941 THRU CE-1017; D-10348, D-10364 THRU D-10403; EA-192 THRU EA-319, EA-321 THRU EA-349
2. E-1809 THRU E-1945, E-1947 THRU E-1953, E-1955 THRU E-1987; CE-941 THRU CE-989; D-10348, D-10364 THRU D-10389; EA-192 THRU EA-241, EA-243 THRU EA-272
3. E-1954, E-1988 THRU E-2070; CE-990 THRU CE-1017; D-10390 THRU D-10403; EA-242, EA-273 THRU EA-319, EA-321 THRU EA-349

Beechcraft
BONANZA
WIRING DIAGRAM MANUAL

21-52-01

Configuration 2

**E-2071 THRU E-2103, E-2105 THRU E-2110; CE-1018 AND AFTER;
CJ-156 AND AFTER; D-10404 AND AFTER; EA-350 THRU EA-388**

Beechcraft
BONANZA
WIRING DIAGRAM MANUAL

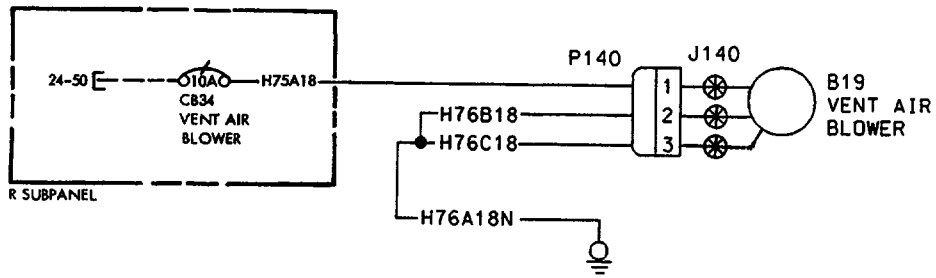

BLOWER-FRESH AIR VENT (OPTIONAL)
(Configuration 2)

Beechcraft
BONANZA
WIRING DIAGRAM MANUAL

REFERENCE DESIGNATOR	PART NUMBER	DESCRIPTION	USABLE	
			INSTL	ON ZONE CODE
21-52-01 (Configuration 2)				
B19	58-380108-1	BLOWER-FRESH AIR VENT (OPTL)	310	1
CB34	35-380132-33	CIRCUIT BREAKER-VENT AIR BLOWER (OPTL)	240	1
J140	207359-1	RECEPTACLE-VENT AIR BLOWER (OPTL)	310	1
P140	207360-1	PLUG-VENT AIR BLOWER (OPTL)	310	1

EFFECTIVITY CODE

1. E-2071 THRU E-2103, E-2105 THRU E-2110; CE-1018 AND AFTER; CJ-156 AND AFTER; D-10404 AND AFTER; EA-350 THRU EA-388

CHAPTER

23

COMMUNICATIONS

Beechcraft
BONANZA

WIRING DIAGRAM MANUAL

LIST OF PAGES & TABLE OF CONTENTS
for

CHAPTER 23 - COMMUNICATIONS

SYS/SUB-SYS/ CHAP SECTION	PAGE NO.	EFFECTIVE DATE	TABLE OF CONTENTS
23-01-01	Page 1	OCT/95	MICROPHONE SWITCH
	Page 2	OCT/95	
	Page 3	OCT/95	
23-50-01	Page 1	OCT/95	CABIN SPEAKERS
	Page 2	OCT/95	
	Page 3	OCT/95	

Beechcraft
BONANZA
WIRING DIAGRAM MANUAL

23-01-01

**E-1422, E-1551, E-1569, E-1581, E-1594 THRU E-1945, E-1947THRU
E-2103, E-2105 THRU E-2110; CE-919, CE-923, CE-925, CE-927,
CE-929AND AFTER; CJ-156 AND AFTER; D-10348, D-10353 AND
AFTER; EA-21, EA-28, EA-33 THRU EA-319, EA-321 THRU EA-388**

Beechcraft BONANZA WIRING DIAGRAM MANUAL

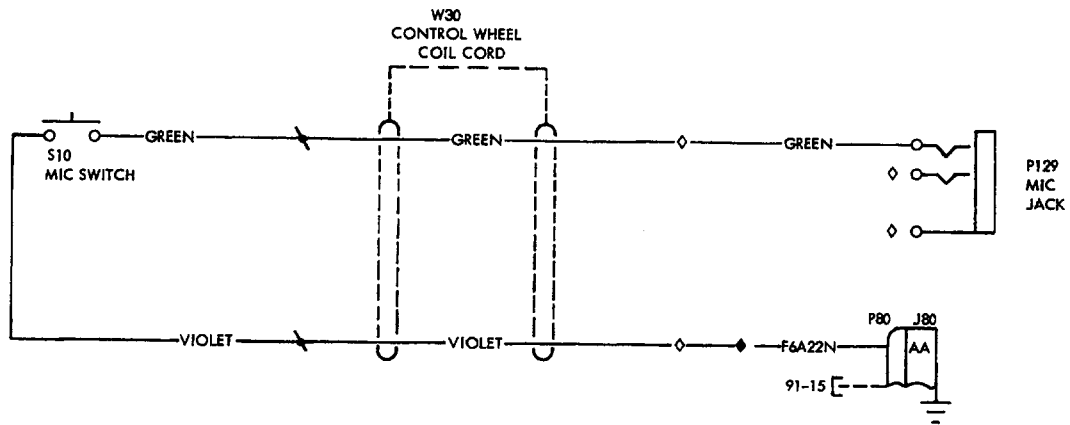

- ◆ ON AIRCRAFT E-1422, E-1551, E-1581,
E-1594 THRU E-1786; CE-919, CE-923,
CE-925, CE-927, CE-929 THRU
CE-933; D-10348, D-10353 THRU
D-10357; EA-21, EA-28, EA-33 THRU
EA-173 WIRE F6A GOES TO ANY OPEN
PIN OF GROUND CONNECTOR P/J80
- ◇ REFERENCE APPROPRIATE AVIONICS
DWG FOR MODE OF CONNECTION

MICROPHONE SWITCH

Beechcraft
BONANZA
WIRING DIAGRAM MANUAL

REFERENCE DESIGNATOR	PART NUMBER	DESCRIPTION	USABLE	
			INSTL	ON ZONE CODE
23-01-01				
J80	204814-1	RECEPTACLE-GROUNDING BLOCK	231	1
P129	JJ-033	MICROPHONE-JACK (OPTL)	240	1
P80A	200838-3	PLUG-GROUNDING BLOCK	231	1
P80B	201224-1	STRAIN RELIEF	231	1
P80C	201328-1	SOCKET CONTACT	231	1
P80D	200333-1	SOCKET CONTACT	231	1
P80E	203618-1	JACKSCREW	231	1
S10	30-1	SWITCH-MICROPHONE (OPTL)	240	1
W30	101-384082-3	COILED CORD	240	1

EFFECTIVITY CODE

1. E-1422, E-1551, E-1569, E-1581, E-1594 THRU E-1945, E-1947THRU E-2103, E-2105 THRU E-2110; CE-919, CE-923, CE-925, CE-927, CE-929AND AFTER; CJ-156 AND AFTER; D-10348, D-10353 AND AFTER; EA-21, EA-28, EA-33 THRU EA-319, EA-321 THRU EA-388

Beechcraft
BONANZA
WIRING DIAGRAM MANUAL

23-50-01

**E-1111, E-1241 THRU E-1945, E-1947 THRU E-2103, E-2105 THRU
E-2110; CE-748, CE-772 AND AFTER; CJ-149 AND AFTER; D-10097,
D-10120 AND AFTER; EA-1 THRU EA-319, EA-321 THRU EA-388**

Beechcraft
BONANZA
WIRING DIAGRAM MANUAL

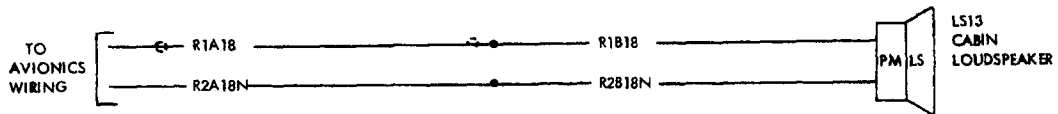

CABIN SPEAKERS

Beechcraft
BONANZA
WIRING DIAGRAM MANUAL

REFERENCE DESIGNATOR	PART NUMBER	DESCRIPTION	USABLE	
			INSTL ZONE	ON CODE
		23-50-01		
LS13	P5	LOUDSPEAKER-CABIN	253	1

EFFECTIVITY CODE

1. E-1111, E-1241 THRU E-1945, E-1947 THRU E-2103, E-2105 THRU E-2110; CE-748, CE-772 AND AFTER; CJ-149 AND AFTER; D-10097, D-10120 AND AFTER; EA-1 THRU EA-319, EA-321 THRU EA-388

CHAPTER

24

**ELECTRICAL
POWER**

Raytheon Aircraft

BEECH BONANZA WIRING DIAGRAM MANUAL

LIST OF PAGES & TABLE OF CONTENTS for CHAPTER 24 - ELECTRICAL POWER

SYS/SUB-SYS/ CHAP SECTION	PAGE NO.	EFFECTIVE DATE	TABLE OF CONTENTS
24-30-01 (Config 1)	Page 1	01/29/99	ALTERNATOR (PRIOR TO INSTALLATION OF KIT 55-3025-1S) (E-1111, E-1241 THRU E-1370; CE-748, CE-772 THRU CE-815; D-10097, D-10120 THRU D-10178; EA-1 ONLY)
	Page 2	01/29/99	
	Page 3	01/29/99	
	Page 4	01/29/99	
	Page 5	01/29/99	
24-30-01 (Config 2)	Page 1	01/29/99	ALTERNATOR (AFTER INSTALLATION OF KIT 55-3025-1S) E-1111, E-1241 THRU E-1370; CE-748, CE-772 THRU CE-815; D-10097, D-10120 THRU D-10178; EA-1 ONLY
	Page 2	01/29/99	
	Page 3	01/29/99	
	Page 4	01/29/99	
	Page 5	01/29/99	
24-30-02 (Config 1)	Page 1	01/29/99	ALTERNATOR (PRIOR TO INSTALLATION OF KIT 55-3025-1S) (E-1371 THRU E-1518; CE-816 THRU CE-861; CJ-149 ONLY; D-10179 THRU D-10247; EA-2 THRU EA-5)
	Page 2	01/29/99	
	Page 3	01/29/99	
	Page 4	01/29/99	
	Page 5	01/29/99	
24-30-02 (Config 2)	Page 1	01/29/99	ALTERNATOR (AFTER INSTALLATION OF KIT 55-3025-1S) E-1371 THRU E-1518; CE-816 THRU CE-861; CJ-149 ONLY; D-10179 THRU D-10247; EA-2 THRU EA-5
	Page 2	01/29/99	
	Page 3	01/29/99	
	Page 4	01/29/99	
	Page 5	01/29/99	
24-30-03 (Config 1)	Page 1	01/29/99	ALTERNATOR (PRIOR TO INSTALLATION OF KIT 55-3025-1S) (E-1519 THRU E-1765; CE-862 THRU CE-928; CJ-150 THRU CJ-155; D-10248 THRU D-10353; EA-6 THRU EA-158)
	Page 2	01/29/99	
	Page 3	01/29/99	
	Page 4	01/29/99	
	Page 5	01/29/99	
24-30-03 (Config 2)	Page 1	01/29/99	ALTERNATOR (AFTER INSTALLATION OF KIT 55-3025-1S) E-1519 THRU E-1765; CE-862 THRU CE-928; CJ-150 THRU CJ-155; D-10248 THRU D-10353; EA-6 THRU EA-158
	Page 2	01/29/99	
	Page 3	01/29/99	
	Page 4	01/29/99	
	Page 5	01/29/99	
24-30-04 (Config 1)	Page 1	01/29/99	ALTERNATOR (PRIOR TO INSTALLATION OF KIT 55-3025-1S) (E-1766 THRU E-1945, E-1947 THRU E-2103, E-2105 THRU E-2110; CE-929 THRU CE-1028; D-10354 AND AFTER; EA-159 THRU EA-319, EA-321 THRU EA-388)
	Page 2	01/29/99	
	Page 3	01/29/99	
	Page 4	01/29/99	
	Page 5	01/29/99	
24-30-04 (Config 2)	Page 1	01/29/99	ALTERNATOR (AFTER INSTALLATION OF KIT 55-3025-1S) E-1766 THRU E-1945, E-1947 THRU E-2103, E-2105 THRU E-2110; CE-929 THRU CE-1028; D-10354 AND AFTER; EA-159 THRU EA-319, EA-321 THRU EA-323
	Page 2	01/29/99	
	Page 3	01/29/99	
	Page 4	01/29/99	
	Page 5	01/29/99	

Raytheon Aircraft

BEECH BONANZA WIRING DIAGRAM MANUAL

LIST OF PAGES & TABLE OF CONTENTS (Continued)
for
CHAPTER 24 - ELECTRICAL POWER

SYS/SUB-SYS/ CHAP SECTION	PAGE NO.	EFFECTIVE DATE	TABLE OF CONTENTS
24-30-04 (Config 3)	Page 1	01/29/99	ALTERNATOR
	Page 2	01/29/99	CE-1029 THRU CE-1791; CJ-156 THRU
	Page 3	01/29/99	CJ-179
	Page 4	01/29/99	
	Page 5	01/29/99	
24-30-04 (Config 4)	Page 1	01/29/99	ALTERNATOR
	Page 2	01/29/99	CE-1792 AND AFTER; CJ-180 AND AFTER
	Page 3	01/29/99	
	Page 4	01/29/99	
	Page 5	01/29/99	
24-31-01	Page 1	Oct/95	VOLTAGE REGULATOR
	Page 2	Oct/95	E-1111, E-1241 THRU E-1945, E-1947 THRU E-2103, E-2105
	Page 3	Oct/95	THRU E-2110; CE-748, CE-772 AND AFTER; CJ-149 THRU CJ-179; D-10097, D-10120 AND AFTER; EA-1 THRU EA-319, EA-321 THRU EA-388
24-33-01	Page 1	01/29/99	POWER - EMERGENCY, DUAL NAVIGATION/COMMUNICA-
	Page 2	01/29/99	TIONS (OPTIONAL) (E-1424 THRU E-1786; CE-834 THRU
	Page 3	01/29/99	CE-933; CJ-149 THRU CJ-155; D-10206 THRU D-10357; EA-
	Page 4	01/29/99	52 THRU EA-173)
	Page 5	01/29/99	
24-33-02	Page 1	01/29/99	POWER - EMERGENCY, DUAL NAVIGATION/COMMUNICA-
	Page 2	01/29/99	TIONS (OPTIONAL) (E-1787 THRU E-1945, E-1947 THRU E-
	Page 3	01/29/99	2103, E-2105 THRU E-2110; CE-934 AND AFTER; CJ-156
	Page 4	01/29/99	AND AFTER; D-10358 AND AFTER; EA-174 THRU EA-319,
	Page 5	01/29/99	EA-321 THRU EA-388)
24-34-01	Page 1	01/29/99	POWER - EMERGENCY, SINGLE NAVIGATION/COMMUNI-
	Page 2	01/29/99	CATIONS (OPTIONAL) (E-1424 THRU E-1786; CE-834 THRU
	Page 3	01/29/99	CE-933; CJ-149 THRU CJ-155; D-10206 THRU D-10357; EA-
	Page 4	01/29/99	52 THRU EA-173)
	Page 5	01/29/99	
24-34-02	Page 1	01/29/99	POWER - EMERGENCY, SINGLE NAVIGATION/COMMUNI-
	Page 2	01/29/99	CATIONS (OPTIONAL) (E-1787 THRU E-1945, E-1947 THRU
	Page 3	01/29/99	E-2103, E-2105 THRU E-2110; CE-934 AND AFTER; CJ-156-
	Page 4	01/29/99	AND AFTER; D-10358 AND AFTER; EA-174 THRU EA-319,
	Page 5	01/29/99	EA-321 THRU EA-388)
24-40-01	Page 1	Oct/95	POWER - EXTERNAL
	Page 2	Oct/95	E-1111, E-1241 THRU E-1945, E-1947 THRU E-2103, E-2105
	Page 3	01/29/99	THRU E-2110; CE-748, CE-772 AND AFTER; CJ-149 AND AFTER; D-10097, D-10120 AND AFTER; EA-1 THRU EA-319, EA-321 THRU EA-388

Raytheon Aircraft

BEECH BONANZA WIRING DIAGRAM MANUAL

LIST OF PAGES & TABLE OF CONTENTS (Continued)
for
CHAPTER 24 - ELECTRICAL POWER

SYS/SUB-SYS/ CHAP SECTION	PAGE NO.	EFFECTIVE DATE	TABLE OF CONTENTS
24-50-01	Page 1 Page 2 Page 3	Oct/95 Oct/95 Oct/95	SUBPANELS - LEFT AND RIGHT E-1111, E-1241 THRU E-1765; CE-748, CE-772 THRU CE-918, CE-920 THRU CE-928; CJ-149 THRU CJ-155; D-10097, D-10120 THRU D-10347, D-10349 THRU D-10353; EA-1 THRU EA-158
24-50-02 (Config 1)	Page 1 Page 2 Page 3 Page 4 Page 5	Oct/95 Oct/95 Oct/95 Oct/95 Oct/95	SUBPANELS - LEFT AND RIGHT E-1766 THRU E-1945, E-1947 THRU E-2095; CE-919, CE-929 THRU CE-1023; D-10348, D-10354 THRU D-10403; EA-159 THRU EA-319, EA-321 THRU EA-377
24-50-02 (Config 2)	Page 1 Page 2 Page 3	Oct/95 Oct/95 Oct/95	SUBPANELS - LEFT AND RIGHT E-2096 THRU E-2103, E-2105 THRU E-2110; CE-1024 AND AFTER; CJ-156 AND AFTER; D-10404 AND AFTER; EA-378 THRU EA-388
24-51-01	Page 1 Page 2 Page 3	Oct/95 Oct/95 Oct/95	POWER - EMERGENCY, DUAL NAVIGATION/COMMUNICATIONS (OPTIONAL) (E-1424 THRU E-1765; CE-834 THRU CE-918, CE-920 THRU CE-928; CJ-149 THRU CJ-155; D-10206 THRU D-10347, D-10349 THRU D-10353; EA-52 THRU EA-158)
24-51-02 (Config 1)	Page 1 Page 2 Page 3 Page 4 Page 5	Oct/95 Oct/95 Oct/95 Oct/95 Oct/95	POWER - EMERGENCY, DUAL NAVIGATION/COMMUNICATIONS (OPTIONAL) (E-1766 THRU E-1945, E-1947 THRU E-2095; CE-919, CE-929 THRU CE-1023; CJ-156 AND AFTER; D-10348, D-10354 THRU D-10403; EA-159 THRU EA-319, EA-321 THRU EA-377)
24-51-02 (Config 2)	Page 1 Page 2 Page 3	Oct/95 Oct/95 Oct/95	POWER - EMERGENCY, DUAL NAVIGATION/COMMUNICATIONS (OPTIONAL) (E-2096 THRU E-2103, E-2105 THRU E-2110; CE-1024 AND AFTER; D-10404 AND AFTER; EA-378 THRU EA-388)
24-52-01	Page 1 Page 2 Page 3	Oct/95 Oct/95 Oct/95	POWER - EMERGENCY, SINGLE NAVIGATION/COMMUNICATIONS (OPTIONAL) (E-1424 THRU E-1765; CE-834 THRU CE-918, CE-920 THRU CE-928; CJ-149 THRU CJ-155; D-10206 THRU D-10347, D-10349 THRU D-10353; EA-52 THRU EA-158)
24-52-02 (Config 1)	Page 1 Page 2 Page 3 Page 4 Page 5	Oct/95 Oct/95 Oct/95 Oct/95 Oct/95	POWER - EMERGENCY, SINGLE NAVIGATION/COMMUNICATIONS (OPTIONAL) (E-1766 THRU E-1945, E-1947 THRU E-2095; CE-919, CE-929 THRU CE-1023; CJ-156 AND AFTER; D-10348, D-10354 THRU D-10403; EA-159 THRU EA-319, EA-321 THRU EA-377)
24-52-02 (Config 2)	Page 1 Page 2 Page 3 Page 4 Page 5	Oct/95 Oct/95 Oct/95 Oct/95 Oct/95	POWER - EMERGENCY, SINGLE NAVIGATION/COMMUNICATIONS (OPTIONAL) (E-2096 THRU E-2103, E-2105 THRU E-2110; CE-1024 AND AFTER; D-10404 AND AFTER; EA-378 THRU EA-388)

Raytheon Aircraft

BEECH BONANZA WIRING DIAGRAM MANUAL

24-30-01

ALTERNATOR (PRIOR TO INSTALLATION OF KIT 55-3025-1S)

(Configuration 1)

E-1111, E-1241 THRU E-1370; CE-748, CE-772 THRU CE-815; D-10097, D-10120 THRU D-10178; EA-1 ONLY

Raytheon Aircraft

BEECH BONANZA WIRING DIAGRAM MANUAL

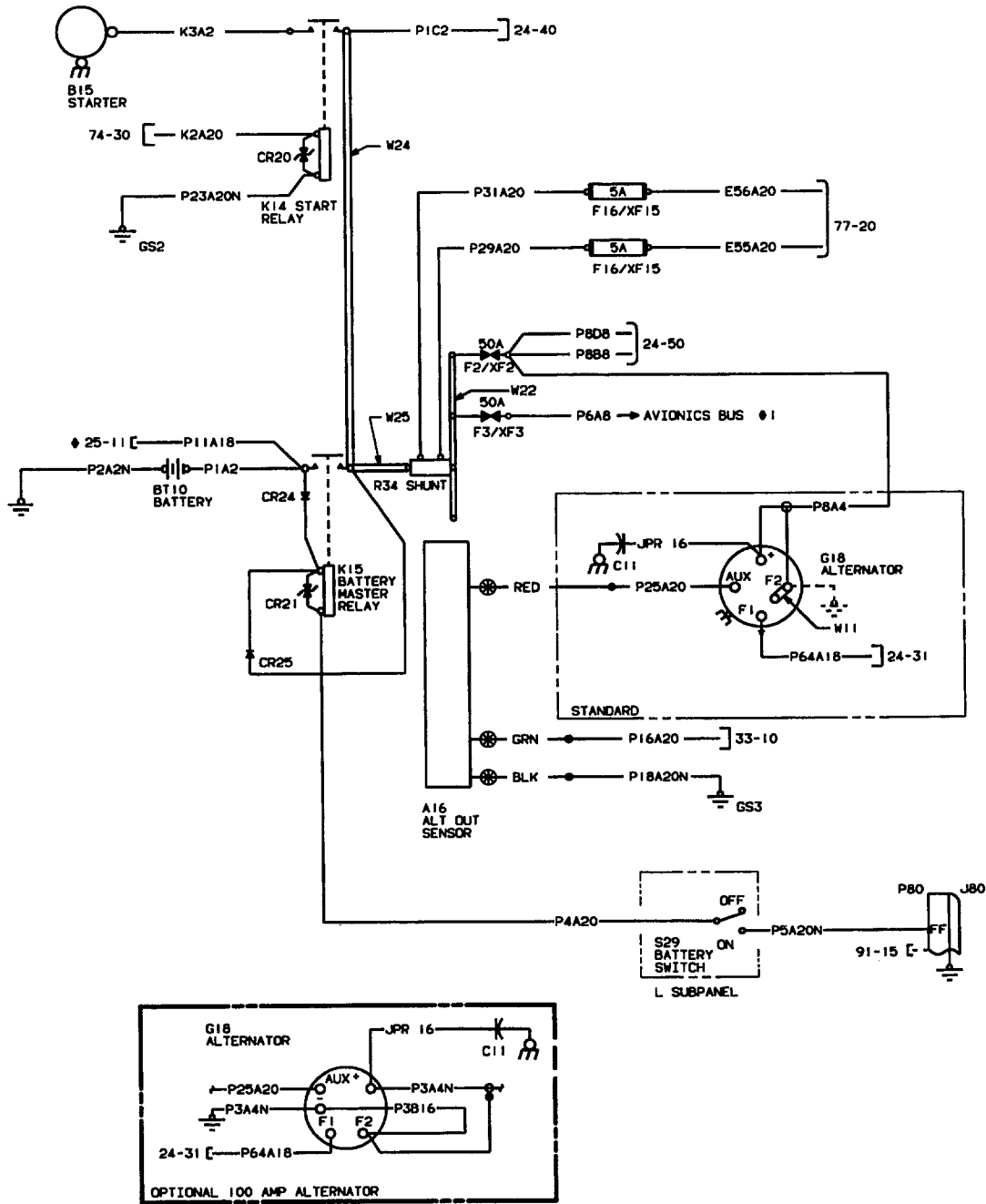

- ON ACFT HAVING OPTIONAL CONTROL WHEEL CLOCK INSTALLED, REF DIAGRAM 25-12 REPLACES REF DIAGRAM 25-11.
- 1 REFER TO APPLICABLE AVIONICS DIAG FOR MODE OF CONNECTION.

CE24F
982520AA

**ALTERNATOR (PRIOR TO INSTALLATION OF KIT 55-3025-1S)
E-1111, E-1241 THRU E-1370; CE-748, CE-772 THRU CE-815; D-10097, D-10120
THRU D-10178; EA-1 ONLY
(Configuration 1)**

Raytheon Aircraft

BEECH BONANZA WIRING DIAGRAM MANUAL

REFERENCE DESIGNATOR	PART NUMBER	DESCRIPTION	INSTL ZONE	USABLE ON CODE
24-30-01				
(Configuration 1)				
A16	36-380000-3	SENSOR-ALTERNATOR OUT	222	1
BT10	36-380059-1	BATTERY (ALTN FOR PS12-11)	222	1
BT10	PS12-11	BATTERY (ALTN FOR 36-380059-1)	222	1
B15	MHJ-4003	MOTOR-STARTER (ALTN FOR 637847)	410	1
B15	637847	MOTOR-STARTER (ALTN FOR MHJ-4003)	410	1
CR20	1.5KE51CA	TRANSZORB-START RELAY	222	1
CR21	1.5KE51CA	TRANSZORB-BATTERY MASTER RELAY	222	1
CR24	1N4007	DIODE-BATTERY MASTER RELAY (SUPERSEDED BY 132408-22)	222	1
CR24	132408-22	DIODE-BATTERY MASTER RELAY (SUPERSEDES 1N4007)	222	1
CR25	1N4007	DIODE-BATTERY MASTER (SUPERSEDED BY 132408-22)	222	1
CR25	132408-22	DIODE-BATTERY MASTER (SUPERSEDES 1N4007)	222	1
C11	121P60501R5V1	CAPACITOR-ALTERNATOR (ALTN FOR 35-360011-5)	410	1
C11	35-360011-5	CAPACITOR-ALTERNATOR (ALTN FOR 121P60501R5V1)	410	1
F15	AGC5	FUSE-AMMETER	222	1
F16	AGC5	FUSE-AMMETER	222	1
F2	FLLA	LIMITER-ELECTRICAL BUS	222	1
F3	FLLA	LIMITER-AVIONICS BUS	222	1
GS2	131270-3	GROUND STUD-FIREWALL	221	1
G18	640789	ALTERNATOR, 100 AMP (OPTL) (ALTN FOR ALV9407)	410	2
G18	641668	ALTERNATOR, 50 AMP (ALTN FOR ALT9422)	410	1
G18	ALT9422	ALTERNATOR, 50 AMP (ALTN FOR 641668)	410	1
G18	ALV9407	ALTERNATOR, 100 AMP (OPTL) (ALTN FOR 640789)	410	2
J80	204814-1	RECEPTACLE-GROUNDING BLOCK	231	1
K14	6041H190	RELAY-START	222	1
K15	6041H189	RELAY-BATTERY MASTER	222	1
P80A	200838-3	PLUG-GROUNDING BLOCK	231	1
P80B	201224-1	STRAIN RELIEF	231	1
P80C	201328-1	SOCKET CONTACT	231	1
P80D	200333-1	SOCKET CONTACT	231	1
P80E	203618-1	JACKSCREW	231	1
R34	MS91586-2	SHUNT-50 AMP	131	1
R34	MS91586-6	SHUNT-100 AMP (OPTL)	222	1
S29	35-380053-21	SWITCH-BATTERY	240	1
W11	002-369014-3	BUS BAR-ALTERNATOR (USED WITH 50 AMP ALTERNATOR)	410	1
W22	002-361016-7	BUS BAR-LIMITER	222	1
W24	36-364001-13	BUS BAR-START RELAY	222	1
W25	36-364001-19	BUS BAR-BATTERY MASTER	222	1
XF15	4532	FUSEHOLDER-AMMETER/CLOCK	222	1
XF2	FSH	LIMITER BASE-ELECTRICAL BUS	222	1
XF3	FSH	LIMITER BASE-AVIONICS BUS	222	1

Raytheon Aircraft

BEECH BONANZA WIRING DIAGRAM MANUAL

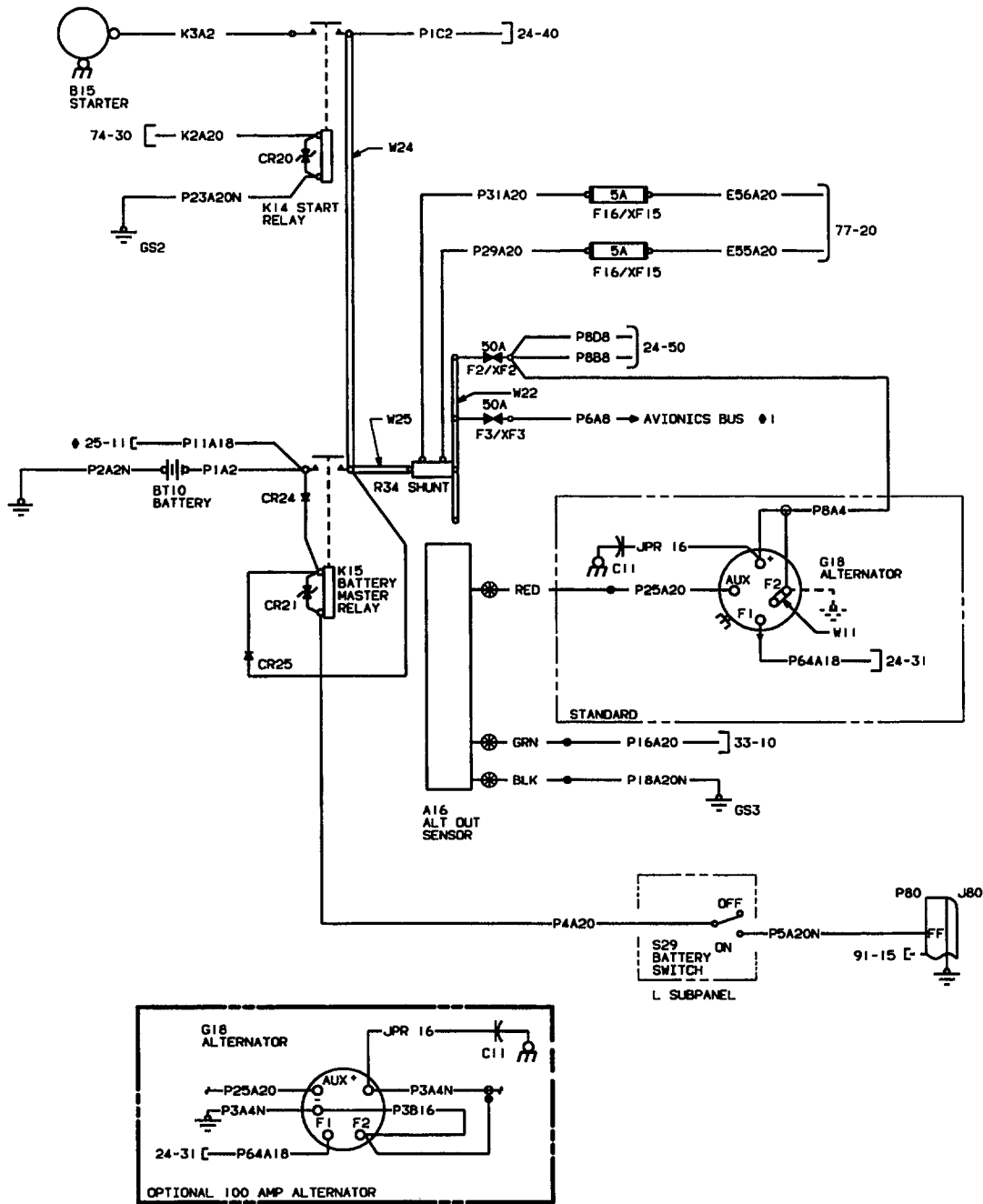

♦ ON ACFT HAVING OPTIONAL CONTROL WHEEL CLOCK INSTALLED, REF DIAGRAM 25-12 REPLACES REF DIAGRAM 25-11.

♦ REFER TO APPLICABLE AVIONICS DIAG FOR MODE OF CONNECTION.

CE24F
982520AA

**ALTERNATOR (PRIOR TO INSTALLATION OF KIT 55-3025-1S)
E-1111, E-1241 THRU E-1370; CE-748, CE-772 THRU CE-815; D-10097, D-10120
THRU D-10178; EA-1 ONLY
(Configuration 1)**

Raytheon Aircraft

BEECH BONANZA WIRING DIAGRAM MANUAL

REFERENCE DESIGNATOR	PART NUMBER	DESCRIPTION	INSTL ZONE	USABLE ON CODE
-------------------------	-------------	-------------	---------------	----------------------

24-30-01
(Configuration 1)

NOTE

REFER TO THE ALTERNATOR (G18)
INSTALLED IN THE AIRPLANE FOR THE
CORRECT PART NUMBER.

CODES OF EFFECTIVITY

1. E-1111, E-1241 THRU E-1370; CE-748, CE-772 THRU CE-815; D-10097, D-10120 THRU D-10178; EA-1 ONLY (PRIOR TO INSTALLATION OF KIT 55-3025-1S)
2. E-1111, E-1241 THRU E-1370; CE-748, CE-772 THRU CE-815; EA-1 ONLY (PRIOR TO INSTALLATION OF KIT 55-3025-1S)

Raytheon Aircraft

BEECH BONANZA WIRING DIAGRAM MANUAL

24-30-01

ALTERNATOR (AFTER INSTALLATION OF KIT 55-3025-1S)

(Configuration 2)

E-1111, E-1241 THRU E-1370; CE-748, CE-772 THRU CE-815; D-10097, D-10120 THRU D-10178; EA-1 ONLY

Raytheon Aircraft

BEECH BONANZA WIRING DIAGRAM MANUAL

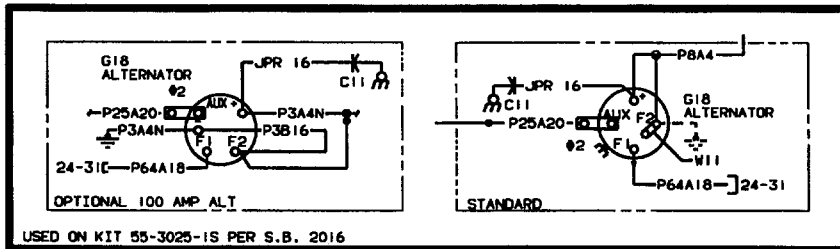
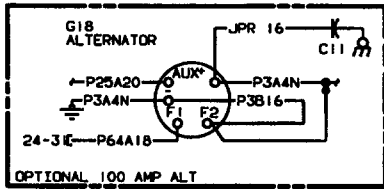
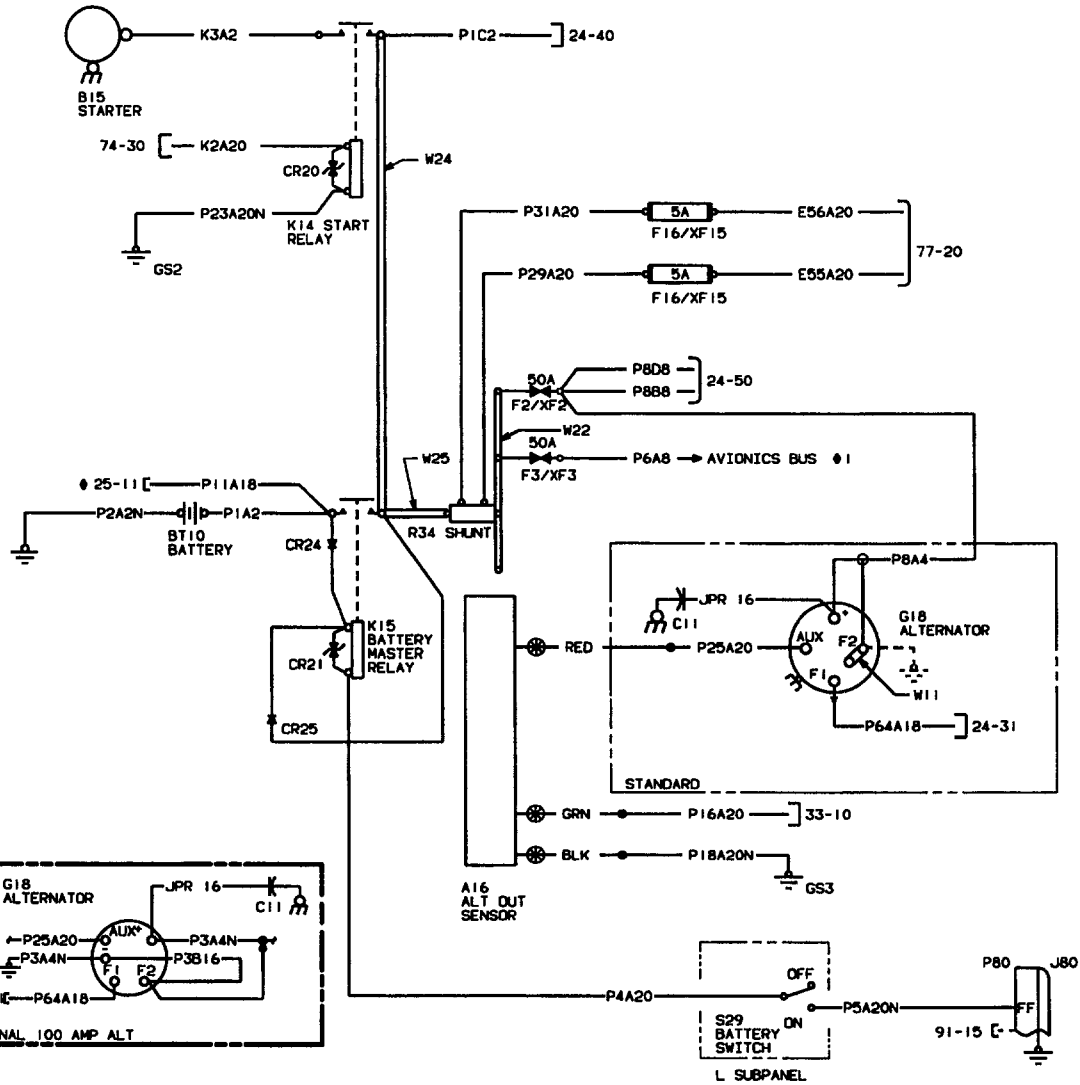

USED ON KIT 55-3025-1S PER S.B. 2016

- ON ACFT HAVING OPTIONAL CONTROL WHEEL CLOCK INSTALLED, REF DIAGRAM 25-12 REPLACES REF DIAGRAM 25-11.
- REFER TO APPLICABLE AVIONICS DIAG FOR MODE OF CONNECTION.
- #2 PC BOARD FUSE PER S.B. 2016

CE24F
982546AA

ALTERNATOR (AFTER INSTALLATION OF KIT 55-3025-1S)
E-1111, E-1241 THRU E-1370; CE-748, CE-772 THRU CE-815; D-10097, D-10120
THRU D-10178; EA-1 ONLY
(Configuration 2)

Raytheon Aircraft

BEECH BONANZA WIRING DIAGRAM MANUAL

REFERENCE DESIGNATOR	PART NUMBER	DESCRIPTION	INSTL ZONE	USABLE ON CODE
24-30-01				
(Configuration 2)				
A16	36-380000-3	SENSOR-ALTERNATOR OUT	222	1
BT10	36-380059-1	BATTERY (ALTN FOR PS12-11)	222	1
BT10	PS12-11	BATTERY (ALTN FOR 36-380059-1)	222	1
B15	MHJ-4003	MOTOR-STARTER (ALTN FOR 637847)	410	1
B15	637847	MOTOR-STARTER (ALTN FOR MHJ-4003)	410	1
CR20	1.5KE51CA	TRANSZORB-START RELAY	222	1
CR21	1.5KE51CA	TRANSZORB-BATTERY MASTER RELAY	222	1
CR24	1N4007	DIODE-BATTERY MASTER RELAY (SUPERSEDED BY 132408-22)	222	1
CR24	132408-22	DIODE-BATTERY MASTER RELAY (SUPERSEDES 1N4007)	222	1
CR25	1N4007	DIODE-BATTERY MASTER (SUPERSEDED BY 132408-22)	222	1
CR25	132408-22	DIODE-BATTERY MASTER (SUPERSEDES 1N4007)	222	1
C11	121P60501R5V1	CAPACITOR-ALTERNATOR (ALTN FOR 35-360011-5)	410	1
C11	35-360011-5	CAPACITOR-ALTERNATOR (ALTN FOR 121P60501R5V1)	410	1
F15	AGC5	FUSE-AMMETER	222	1
F16	AGC5	FUSE-AMMETER	222	1
F2	FLLA	LIMITER-ELECTRICAL BUS	222	1
F3	FLLA	LIMITER-AVIONICS BUS	222	1
GS2	131270-3	GROUND STUD-FIREWALL	221	1
GS3	131270-3	GROUND STUD-FIREWALL	221	1
G18	640789	ALTERNATOR, 100 AMP (OPTL) (ALTN FOR ALV9407)	410	2
G18	641668	ALTERNATOR, 50 AMP (ALTN FOR ALT9422)	410	1
G18	ALT9422	ALTERNATOR, 50 AMP (ALTN FOR 641668)	410	1
G18	ALV9407	ALTERNATOR, 100 AMP (OPTL) (ALTN FOR 640789)	410	2
J80	204814-1	RECEPTACLE-GROUNDING BLOCK	231	1
K14	6041H190	RELAY-START	222	1
K15	6041H189	RELAY-BATTERY MASTER	222	1
P80A	200838-3	PLUG-GROUNDING BLOCK	231	1
P80B	201224-1	STRAIN RELIEF	231	1
P80C	201328-1	SOCKET CONTACT	231	1
P80D	200333-1	SOCKET CONTACT	231	1
P80E	203618-1	JACKSCREW	231	1
R34	MS91586-2	SHUNT-50 AMP	131	1
R34	MS91586-6	SHUNT-100 AMP (OPTL)	222	1
S29	35-380053-21	SWITCH-BATTERY	240	1
W11	002-369014-3	BUS BAR-ALTERNATOR (USED WITH 50 AMP ALTERNATOR)	410	1
W22	002-361016-7	BUS BAR-LIMITER	222	1
W24	36-364001-13	BUS BAR-START RELAY	222	1
W25	36-364001-19	BUS BAR-BATTERY MASTER	222	1
XF15	4532	FUSEHOLDER-AMMETER/CLOCK	222	1
XF2	FSH	LIMITER BASE-ELECTRICAL BUS	222	1
XF3	FSH	LIMITER BASE-AVIONICS BUS	222	1
Y1A		THE FOLLOWING COMPONENTS ARE PART OF KIT 55-3025-1S AND COMPLY WITH S.B. 2016.		
Y1B	55-3025-1S	KIT, PRINTED CIRCUIT BOARD FUSE ASSEMBLY (CONSISTS OF PARTS AND INSTRUCTIONS TO INSTALL A PRINTED CIRCUIT BOARD FUSE DIRECTLY ON THE AUXILIARY OUTPUT TERMINAL OF THE ALTERNATOR)		1

Raytheon Aircraft

BEECH BONANZA WIRING DIAGRAM MANUAL

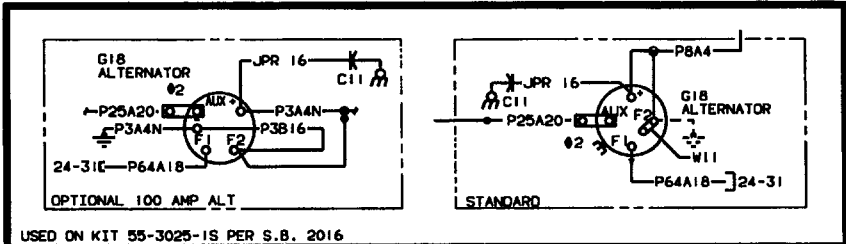
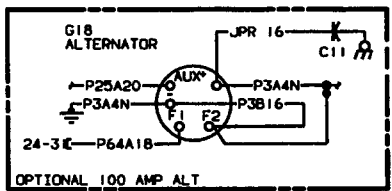
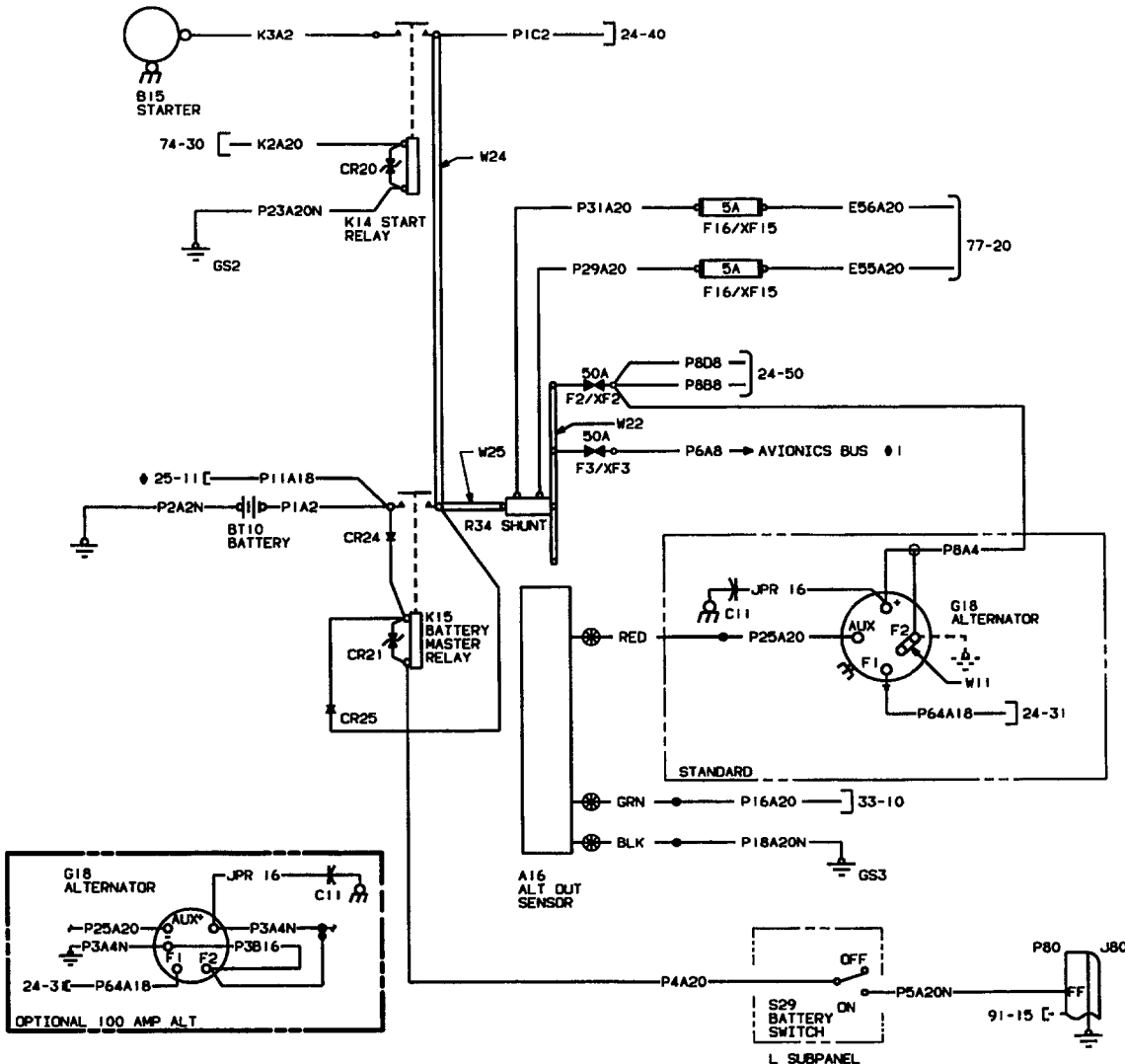

- ◆ ON ACFT HAVING OPTIONAL CONTROL WHEEL CLOCK INSTALLED, REF DIAGRAM 25-12 REPLACES REF DIAGRAM 25-11.
- ◆1 REFER TO APPLICABLE AVIONICS DIAG FOR MODE OF CONNECTION.
- ◆2 PC BOARD FUSE PER S.B. 2016

CE24F
982546AA

ALTERNATOR (AFTER INSTALLATION OF KIT 55-3025-1S)
E-1111, E-1241 THRU E-1370; CE-748, CE-772 THRU CE-815; D-10097, D-10120
THRU D-10178; EA-1 ONLY
(Configuration 2)

Raytheon Aircraft

BEECH BONANZA WIRING DIAGRAM MANUAL

REFERENCE DESIGNATOR	PART NUMBER	DESCRIPTION	INSTL ZONE	USABLE ON CODE
		24-30-01 (Configuration 2)		
Y1C	58-360006-1	ALTERNATOR CONTROL RESISTOR ASSEMBLY- ALTERNATOR FUSE (A COMPONENT PART OF KIT 55-3025-1S) (SUPERSEDES 58-361014-1)		1
Y1D	58-361015-1	PRINTED CIRCUIT BOARD (A COMPONENT PART OF KIT 55-3025-1S)		1
Y1E	WF2K10R	RESISTOR, FUSIBLE (A COMPONENT PART OF KIT 55-3025-1S)		1
Y1F	9505-08	NUTSERT (A COMPONENT PART OF KIT 55-3025-1S)		1

NOTE

REFER TO THE ALTERNATOR (G18)
INSTALLED IN THE AIRPLANE FOR THE
CORRECT PART NUMBER.

CODES OF EFFECTIVITY

1. E-1111, E-1241 THRU E-1370; CE-748, CE-772 THRU CE-815; D-10097, D-10120 THRU D-10178; EA-1 ONLY (AFTER INSTALLATION OF KIT 55-3025-1S)
2. E-1111, E-1241 THRU E-1370; CE-748, CE-772 THRU CE-815; EA-1 ONLY (AFTER INSTALLATION OF KIT 55-3025-1S)

Raytheon Aircraft

BEECH BONANZA WIRING DIAGRAM MANUAL

24-30-02

ALTERNATOR (PRIOR TO INSTALLATION OF KIT 55-3025-1S)

(Configuration 1)

E-1371 THRU E-1518; CE-816 THRU CE-861; CJ-149 ONLY; D-10179 THRU D-10247; EA-2 THRU EA-5

Raytheon Aircraft

BEECH BONANZA WIRING DIAGRAM MANUAL

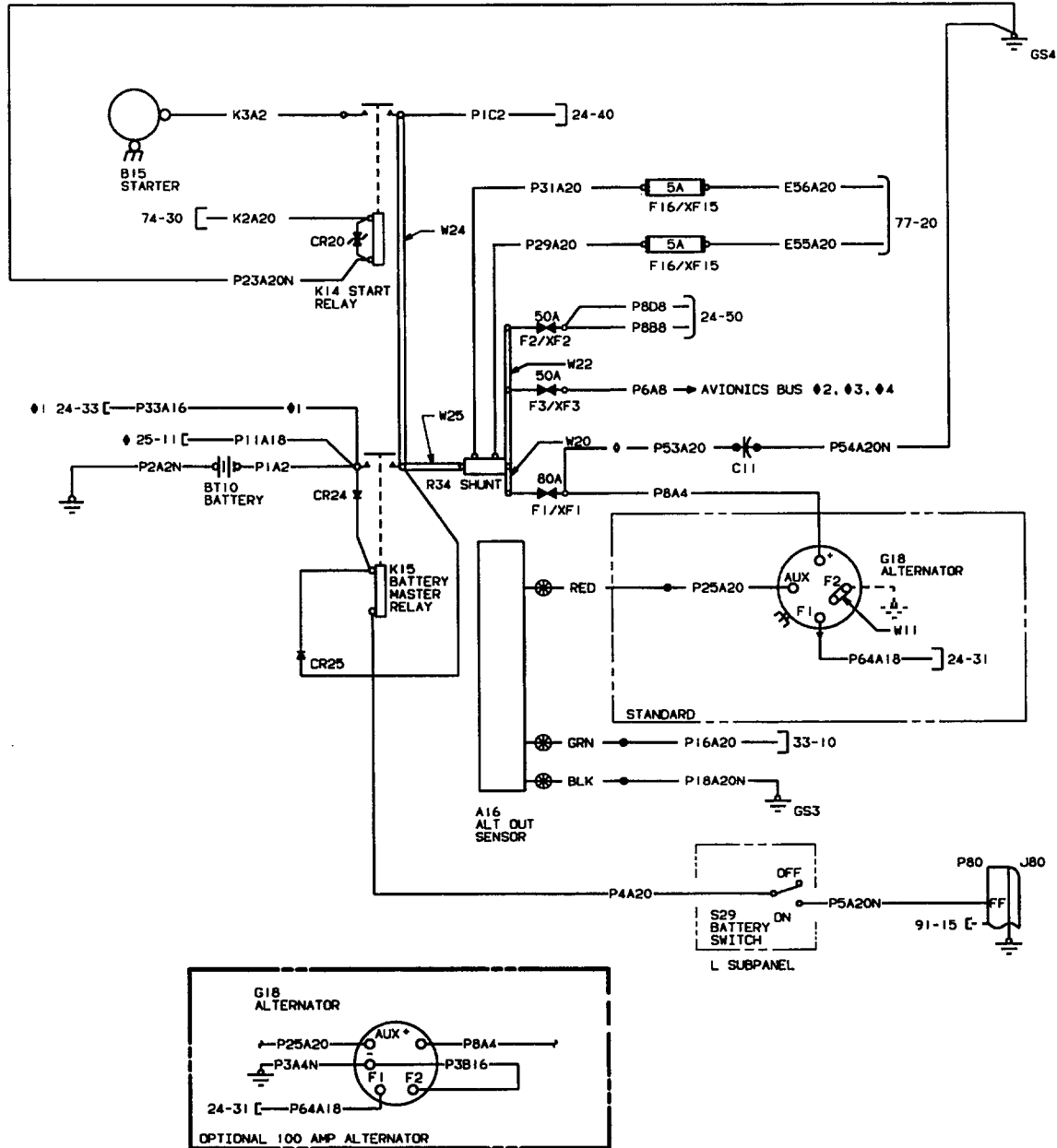

- ◆4 WHEN OPTIONAL SINGLE NAV IS USED REFER TO DIAG 24-52 & 24-34
- ◆3 WHEN OPTIONAL DUAL NAV IS USED REFER TO DIAG 24-51 & 24-33
- ◆2 REFER TO APPLICABLE AVIONICS DIAG FOR MODE OF CONNECTION.
- ◆1 ON AIRCRAFT E-1371 THRU E-1423, EA-2 THRU EA-5, CE-816 THRU CE-833 AND D-10179 THRU D-10205 NOT USED
- ◆ ON AIRCRAFT HAVING OPTIONAL CONTROL WHEEL CLOCK INSTALLED, REF DIAGRAM 25-12 REPLACES REF DIAGRAM 25-11.
- ◆ WIRE LENGTH MUST BE KEPT LESS THAN 6 INCHES

CE24F
982521AA

ALTERNATOR (PRIOR TO INSTALLATION OF KIT 55-3025-1S)
E-1371 THRU E-1518; CE-816 THRU CE-861; CJ-149 ONLY; D-10179 THRU D-10247;
EA-2 THRU EA-5
(Configuration 1)

Raytheon Aircraft

BEECH BONANZA WIRING DIAGRAM MANUAL

REFERENCE DESIGNATOR	PART NUMBER	DESCRIPTION	INSTL ZONE	USABLE ON CODE
24-30-02				
(Configuration 1)				
A16	36-380000-3	SENSOR-ALTERNATOR OUT	222	1
BT10	36-380059-1	BATTERY (ALTN FOR PS12-11)	222	1
BT10	PS12-11	BATTERY (ALTN FOR 36-380059-1)	222	1
B15	MHJ-4003	MOTOR-STARTER (ALTN FOR 637847)	410	1
B15	637847	MOTOR-STARTER (ALTN FOR MHJ-4003)	410	1
CR20	1.5KE51CA	TRANSZORB-START RELAY	222	1
CR24	1N4007	DIODE-BATTERY MASTER RELAY (SUPERSEDED BY 132408-22)	222	1
CR24	132408-22	DIODE-BATTERY MASTER RELAY (SUPERSEDES 1N4007)	222	1
CR25	1N4007	DIODE-BATTERY MASTER (SUPERSEDED BY 132408-22)	222	1
CR25	132408-22	DIODE-BATTERY MASTER (SUPERSEDES 1N4007)	222	1
C11	39D507G050GL4	CAPACITOR-ALTERNATOR (OPTL)	410	1
F1	FLLB	LIMITER-ALTERNATOR	222	1
F15	AGC5	FUSE-AMMETER	222	1
F16	AGC5	FUSE-AMMETER	222	1
F2	FLLA	LIMITER-ELECTRICAL BUS	222	1
F3	FLLA	LIMITER-AVIONICS BUS	222	1
GS3	131270-3	GROUND STUD-FIREWALL	221	1
GS4	AN3-5A	GROUND STUD-LOWER FIREWALL	222	1
G18	641668	ALTERNATOR, 50 AMP (ALTN FOR ALT9422)	410	1
G18	ALT9422	ALTERNATOR, 50 AMP (ALTN FOR 641668)	410	1
G18	640789	ALTERNATOR, 100 AMP (OPTL) (ALTN FOR ALV9407)	410	1
G18	ALV9407	ALTERNATOR, 100 AMP (OPTL) (ALTN FOR 640789)	410	1
J80	204814-1	RECEPTACLE-GROUNDING BLOCK	231	1
K14	6041H190	RELAY-START	222	1
K15	6041H189	RELAY-BATTERY MASTER	222	1
P80A	200838-3	PLUG-GROUNDING BLOCK	231	1
P80B	201224-1	STRAIN RELIEF	231	1
P80C	201328-1	SOCKET CONTACT	231	1
P80D	200333-1	SOCKET CONTACT	231	1
P80E	203618-1	JACKSCREW	231	1
R34	MS91586-2	SHUNT-50 AMP	131	1
R34	MS91586-6	SHUNT-100 AMP (OPTL)	222	1
S29	35-380053-21	SWITCH-BATTERY	240	1
W11	002-369014-3	BUS BAR-ALTERNATOR (USED WITH 50 AMP ALTERNATOR)	410	1
W20	36-364001-27	BUS BAR-SHUNT, AVIONICS LIMITER	222	1
W22	002-361016-7	BUS BAR-LIMITER	222	1
W24	36-364001-13	BUS BAR-START RELAY	222	1
W25	36-364001-19	BUS BAR-BATTERY MASTER	222	1
XF1	FSH	LIMITER BASE-ALTERNATOR	222	1
XF15	4532	FUSEHOLDER-AMMETER/CLOCK	222	1
XF2	FSH	LIMITER BASE-ELECTRICAL BUS	222	1
XF3	FSH	LIMITER BASE-AVIONICS BUS	222	1

Raytheon Aircraft

BEECH BONANZA WIRING DIAGRAM MANUAL

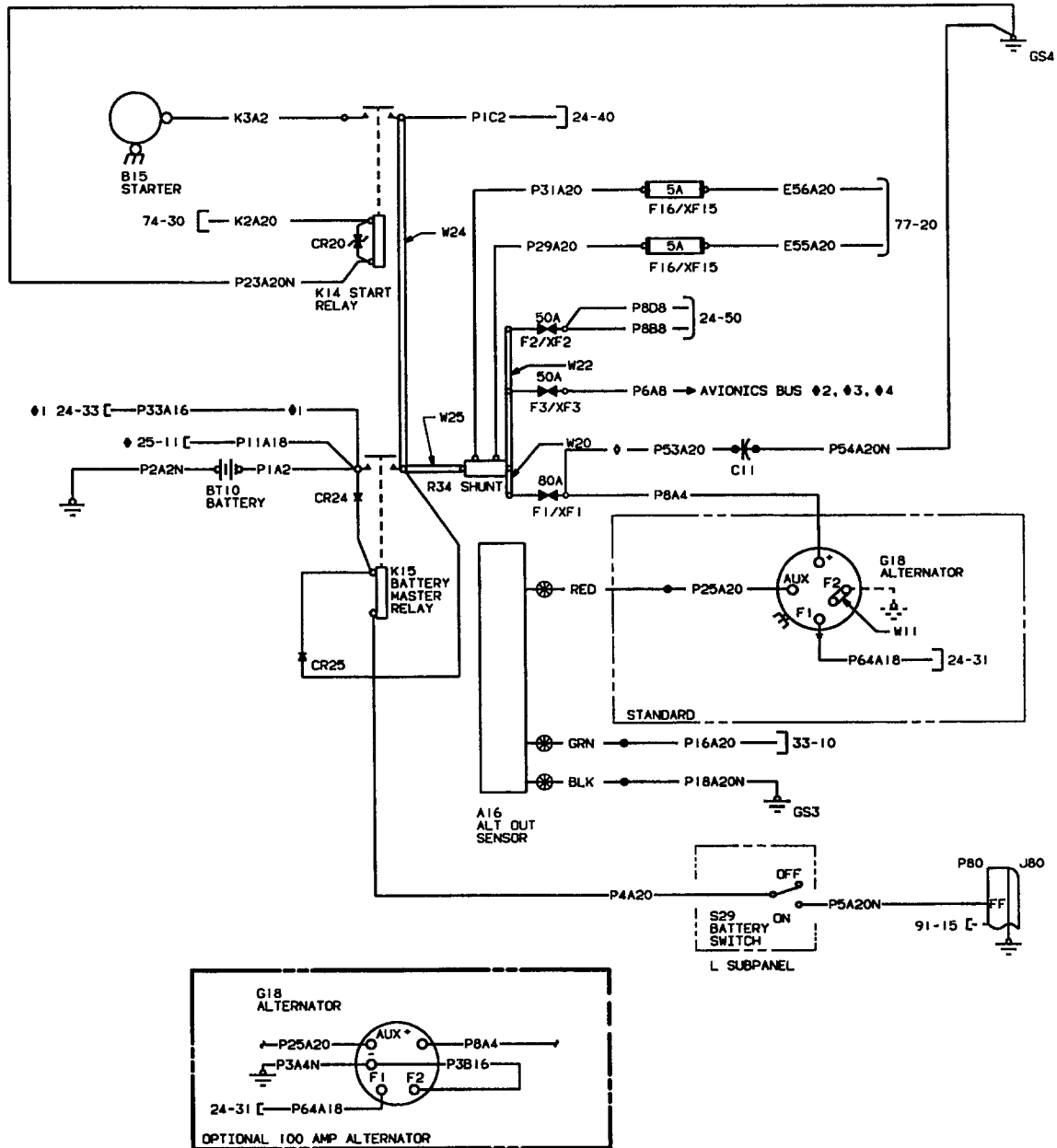

- ◆4 WHEN OPTIONAL SINGLE NAV IS USED REFER TO DIAG 24-52 & 24-34
- ◆3 WHEN OPTIONAL DUAL NAV IS USED REFER TO DIAG 24-51 & 24-33
- ◆2 REFER TO APPLICABLE AVIONICS DIAG FOR MODE OF CONNECTION.

◆1 ON AIRCRAFT E-1371 THRU E-1423, EA-2 THRU EA-5, CE-816 THRU CE-833 AND D-10179 THRU D-10205 NOT USED

◆ ON AIRCRAFT HAVING OPTIONAL CONTROL WHEEL CLOCK INSTALLED, REF DIAGRAM 25-12 REPLACES REF DIAGRAM 25-11.

◆ WIRE LENGTH MUST BE KEPT LESS THAN 6 INCHES

CE24F
982521AA

**ALTERNATOR (PRIOR TO INSTALLATION OF KIT 55-3025-1S)
E-1371 THRU E-1518; CE-816 THRU CE-861; CJ-149 ONLY; D-10179 THRU D-10247;
EA-2 THRU EA-5
(Configuration 1)**

Raytheon Aircraft

BEECH BONANZA WIRING DIAGRAM MANUAL

REFERENCE DESIGNATOR	PART NUMBER	DESCRIPTION	INSTL ZONE	USABLE ON CODE
-------------------------	-------------	-------------	---------------	----------------------

24-30-02
(Configuration 1)

NOTE

REFER TO THE ALTERNATOR (G18)
INSTALLED IN THE AIRPLANE FOR THE
CORRECT PART NUMBER.

CODES OF EFFECTIVITY

1. E-1371 THRU E-1518; CE-816 THRU CE-861; CJ-149 ONLY; D-10179 THRU D-10247; EA-2 THRU EA-5 (PRIOR TO INSTALLATION OF KIT 55-3025-1S)

Raytheon Aircraft

BEECH BONANZA WIRING DIAGRAM MANUAL

24-30-02

ALTERNATOR (AFTER INSTALLATION OF KIT 55-3025-1S)

(Configuration 2)

E-1371 THRU E-1518; CE-816 THRU CE-861; CJ-149 ONLY; D-10179 THRU D-10247; EA-2 THRU EA-5

Raytheon Aircraft

BEECH BONANZA WIRING DIAGRAM MANUAL

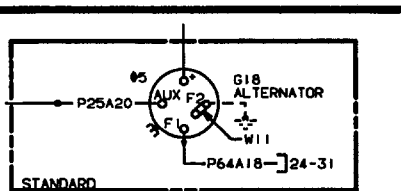
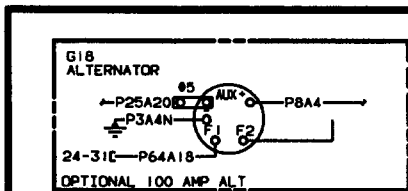
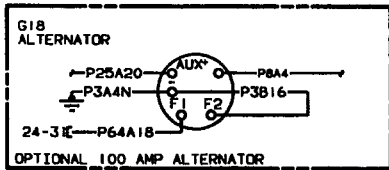
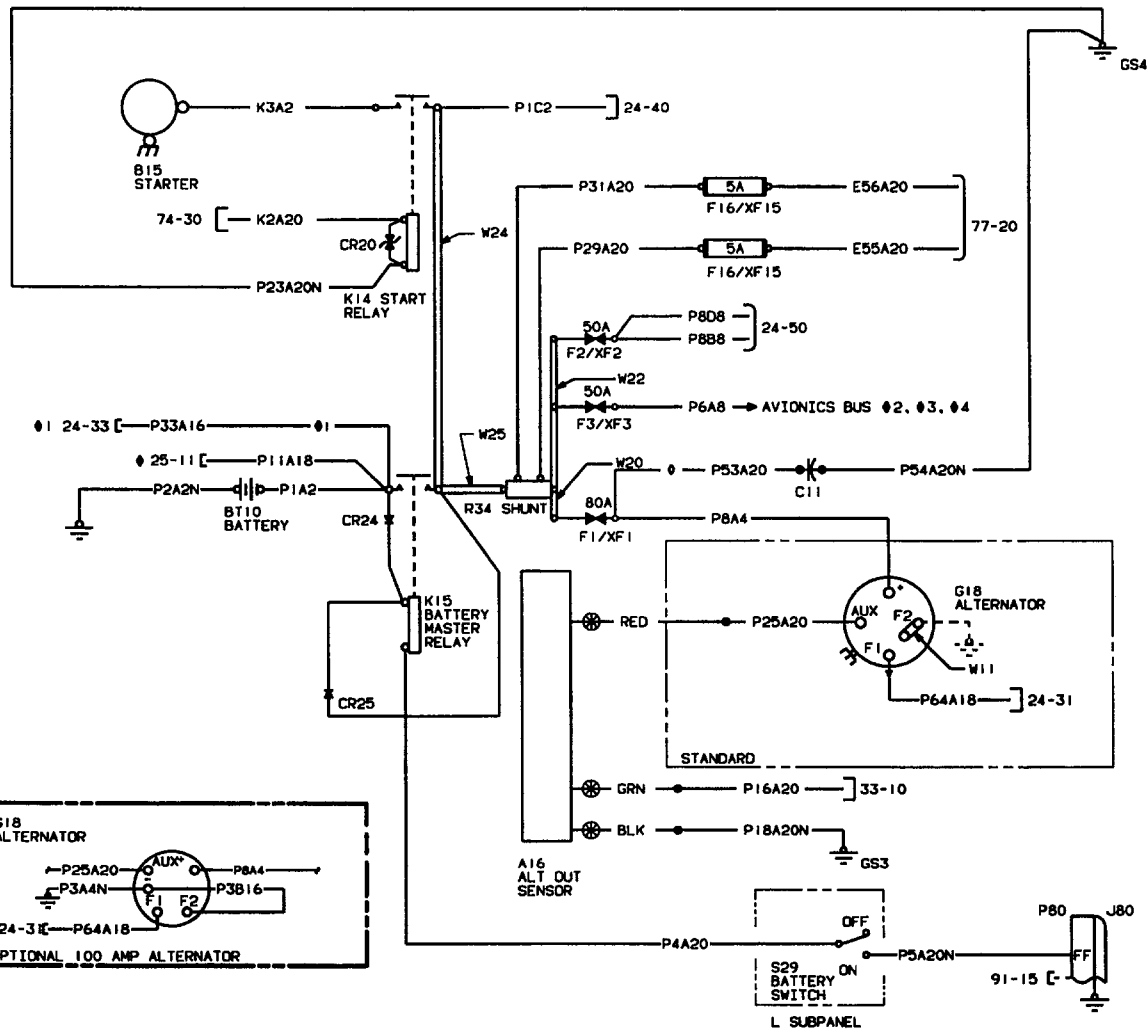

USED ON KIT 55-3025-1S PER S.B. 2016

- ◆4 WHEN OPTIONAL SINGLE NAV IS USED REFER TO DIAG 24-52 & 24-34
- ◆3 WHEN OPTIONAL DUAL NAV IS USED REFER TO DIAG 24-51 & 24-33
- ◆2 REFER TO APPLICABLE AVIONICS DIAG FOR MODE OF CONNECTION.
- ◆1 ON AIRCRAFT E-1371 THRU E-1423, EA-2 THRU EA-5, CE-816 THRU CE-833 AND D-10179 THRU D-10205 NOT USED
- ◆ ON AIRCRAFT HAVING OPTIONAL CONTROL WHEEL CLOCK INSTALLED, REF DIAGRAM 25-12 REPLACES REF DIAGRAM 25-11.
- ◆ WIRE LENGTH MUST BE KEPT LESS THAN 6 INCHES
- ◆5 PC BOARD FUSE PER S.B. 2016

CE24F
982547AA

ALTERNATOR (AFTER INSTALLATION OF KIT 55-3025-1S)
E-1371 THRU E-1518; CE-816 THRU CE-861; CJ-149 ONLY; D-10179 THRU D-10247;
EA-2 THRU EA-5
(Configuration 2)

Raytheon Aircraft

BEECH BONANZA WIRING DIAGRAM MANUAL

REFERENCE DESIGNATOR	PART NUMBER	DESCRIPTION	INSTL ZONE	USABLE ON CODE
24-30-02				
(Configuration 2)				
A16	36-380000-3	SENSOR-ALTERNATOR OUT	222	1
BT10	36-380059-1	BATTERY (ALTN FOR PS12-11)	222	1
BT10	PS12-11	BATTERY (ALTN FOR 36-380059-1)	222	1
B15	MHJ-4003	MOTOR-STARTER (ALTN FOR 637847)	410	1
B15	637847	MOTOR-STARTER (ALTN FOR MHJ-4003)	410	1
CR20	1.5KE51CA	TRANSZORB-START RELAY	222	1
CR24	1N4007	DIODE-BATTERY MASTER RELAY (SUPERSEDED BY 132408-22)	222	1
CR24	132408-22	DIODE-BATTERY MASTER RELAY (SUPERSEDES 1N4007)	222	1
CR25	1N4007	DIODE-BATTERY MASTER (SUPERSEDED BY 132408-22)	222	1
CR25	132408-22	DIODE-BATTERY MASTER (SUPERSEDES 1N4007)	222	1
C11	39D507G050GL4	CAPACITOR-ALTERNATOR (OPTL)	410	1
F1	FLLB	LIMITER-ALTERNATOR	222	1
F15	AGC5	FUSE-AMMETER	222	1
F16	AGC5	FUSE-AMMETER	222	1
F2	FLLA	LIMITER-ELECTRICAL BUS	222	1
F3	FLLA	LIMITER-AVIONICS BUS	222	1
GS3	131270-3	GROUND STUD-FIREWALL	221	1
GS4	AN3-5A	GROUND STUD-LOWER FIREWALL	222	1
G18	641668	ALTERNATOR, 50 AMP (ALTN FOR ALT9422)	410	1
G18	ALT9422	ALTERNATOR, 50 AMP (ALTN FOR 641668)	410	1
G18	ALV9407	ALTERNATOR, 100 AMP (OPTL) (ALTN FOR 640789)	410	1
G18	640789	ALTERNATOR, 100 AMP (OPTL) (ALTN FOR ALV9407)	410	1
J80	204814-1	RECEPTACLE-GROUNDING BLOCK	231	1
K14	6041H190	RELAY-START	222	1
K15	6041H189	RELAY-BATTERY MASTER	222	1
P80A	200838-3	PLUG-GROUNDING BLOCK	231	1
P80B	201224-1	STRAIN RELIEF	231	1
P80C	201328-1	SOCKET CONTACT	231	1
P80D	200333-1	SOCKET CONTACT	231	1
P80E	203618-1	JACKSCREW	231	1
R34	MS91586-2	SHUNT-50 AMP	131	1
R34	MS91586-6	SHUNT-100 AMP (OPTL)	222	1
S29	35-380053-21	SWITCH-BATTERY	240	1
W11	002-369014-3	BUS BAR-ALTERNATOR (USED WITH 50 AMP ALTERNATOR)	410	1
W20	36-364001-27	BUS BAR-SHUNT, AVIONICS LIMITER	222	1
W22	002-361016-7	BUS BAR-LIMITER	222	1
W24	36-364001-13	BUS BAR-START RELAY	222	1
W25	36-364001-19	BUS BAR-BATTERY MASTER	222	1
XF1	FSH	LIMITER BASE-ALTERNATOR	222	1
XF15	4532	FUSEHOLDER-AMMETER/CLOCK	222	1
XF2	FSH	LIMITER BASE-ELECTRICAL BUS	222	1
XF3	FSH	LIMITER BASE-AVIONICS BUS	222	1
Y1A		THE FOLLOWING COMPONENTS ARE PART OF KIT 55-3025-1S AND COMPLY WITH S.B. 2016.		
Y1B	55-3025-1S	KIT, PRINTED CIRCUIT BOARD FUSE ASSEMBLY (CONSISTS OF PARTS AND INSTRUCTIONS TO INSTALL A PRINTED CIRCUIT BOARD FUSE DIRECTLY ON THE AUXILIARY OUTPUT TERMINAL OF THE ALTERNATOR)		1

Raytheon Aircraft

BEECH BONANZA WIRING DIAGRAM MANUAL

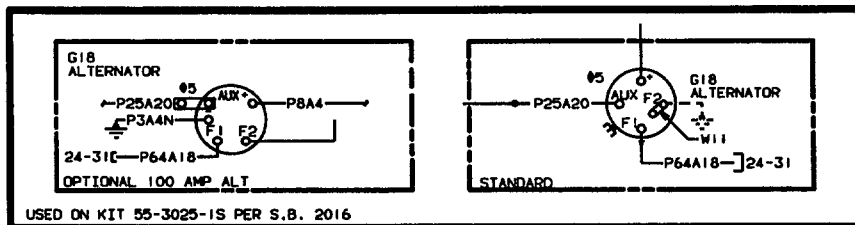
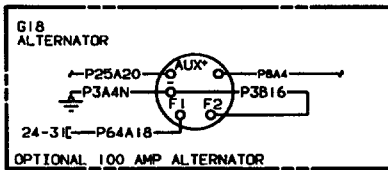
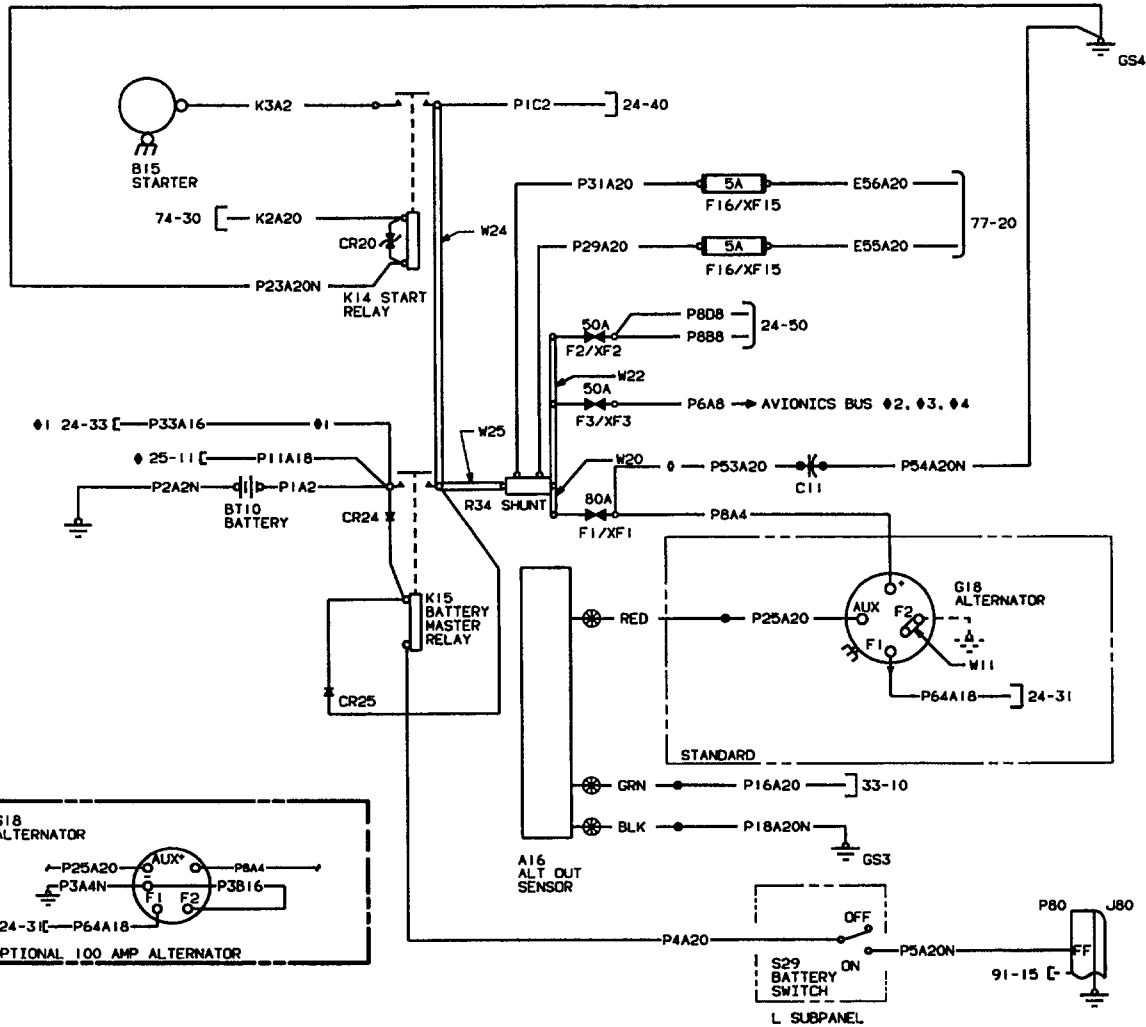

- ◆4 WHEN OPTIONAL SINGLE NAV IS USED REFER TO DIAG 24-52 & 24-34
- ◆3 WHEN OPTIONAL DUAL NAV IS USED REFER TO DIAG 24-51 & 24-33
- ◆2 REFER TO APPLICABLE AVIONICS DIAG FOR MODE OF CONNECTION.
- ◆1 ON AIRCRAFT E-1371 THRU E-1423, EA-2 THRU EA-5, CE-816 THRU CE-833 AND D-10179 THRU D-10205 NOT USED
- ◆ ON AIRCRAFT HAVING OPTIONAL CONTROL WHEEL CLOCK INSTALLED, REF DIAGRAM 25-12 REPLACES REF DIAGRAM 25-11.
- ◆ WIRE LENGTH MUST BE KEPT LESS THAN 6 INCHES
- ◆5 PC BOARD FUSE PER S.B. 2016

CE24F
982547AA

ALTERNATOR (AFTER INSTALLATION OF KIT 55-3025-1S)
E-1371 THRU E-1518; CE-816 THRU CE-861; CJ-149 ONLY; D-10179 THRU D-10247;
EA-2 THRU EA-5
(Configuration 2)

Raytheon Aircraft

BEECH BONANZA WIRING DIAGRAM MANUAL

REFERENCE DESIGNATOR	PART NUMBER	DESCRIPTION	INSTL ZONE	USABLE ON CODE
		24-30-02 (Configuration 2)		
Y1C	58-360006-1	ALTERNATOR CONTROL RESISTOR ASSEMBLY- ALTERNATOR FUSE (A COMPONENT PART OF KIT 55-3025-1S) (SUPERSEDES 58-361014-1)		1
Y1D	58-361015-1	PRINTED CIRCUIT BOARD (A COMPONENT PART OF KIT 55-3025-1S)		1
Y1E	WF2K10R	RESISTOR, FUSIBLE (A COMPONENT PART OF KIT 55-3025-1S)		1
Y1F	9505-08	NUTSERT (A COMPONENT PART OF KIT 55-3025-1S)		1

NOTE

REFER TO THE ALTERNATOR (G18)
INSTALLED IN THE AIRPLANE FOR THE
CORRECT PART NUMBER.

CODES OF EFFECTIVITY

1. E-1371 THRU E-1518; CE-816 THRU CE-861; CJ-149 ONLY; D-10179 THRU D-10247; EA-2 THRU EA-5 (AFTER INSTALLATION OF KIT 55-3025-1S)

Raytheon Aircraft

BEECH BONANZA WIRING DIAGRAM MANUAL

24-30-03

ALTERNATOR (PRIOR TO INSTALLATION OF KIT 55-3025-1S)

(Configuration 1)

E-1519 THRU E-1765; CE-862 THRU CE-928; CJ-150 THRU CJ-155; D-10248 THRU D-10353; EA-6 THRU
EA-158

Raytheon Aircraft

BEECH BONANZA WIRING DIAGRAM MANUAL

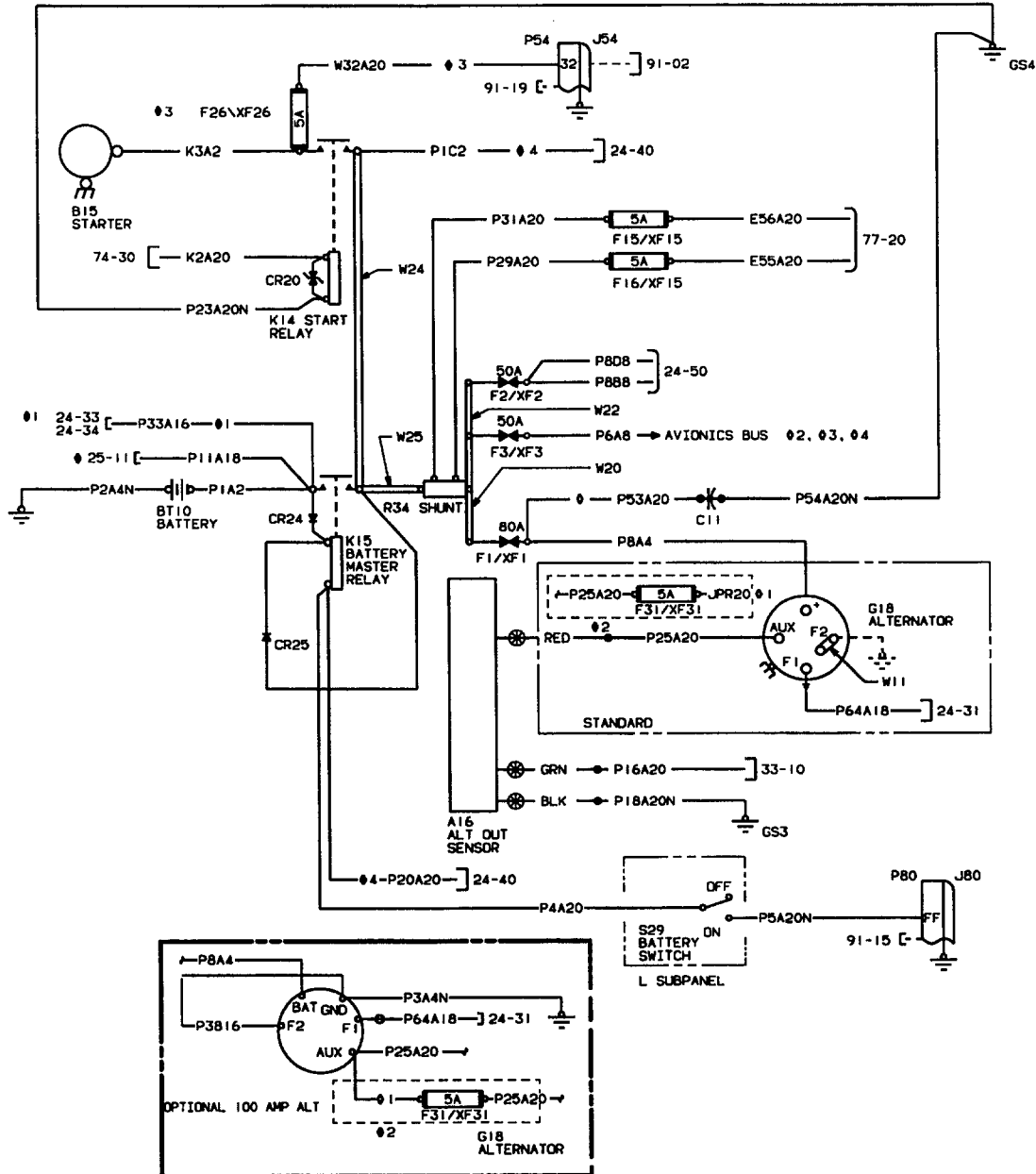

- Ø2 REFER TO APPLICABLE AVIONICS DIAG FOR MODE OF CONNECTION.
- Ø3 WHEN OPTIONAL DUAL NAV IS USED REFER TO DIAG 24-51.
- Ø4 WHEN OPTIONAL SINGLE NAV IS USED REFER TO DIAG 24-52.
- Ø4 USED ON ACFT WITH EXTERNAL POWER OPTION
- Ø3 USED ON ACFT CE-919, CE-923, CE-925 & CE-927 ONLY
- Ø2 WIRE AS SHOWN EA-158 ONLY
- Ø1 ON ACFT EA-6 & AFT NOT USED
- Ø ON ACFT HAVING OPTIONAL CONTROL WHEEL CLOCK INSTALLED, REF DIAGRAM 25-12 REPLACES REF DIAGRAM 25-11.
- Ø1 WIRE LENGTH MUST BE KEPT LESS THAN 3-INCHES.
- Ø WIRE LENGTH MUST BE KEPT LESS THAN 6-INCHES.

CE24F
982522AA

ALTERNATOR (PRIOR TO INSTALLATION OF KIT 55-3025-1S)
E-1519 THRU E-1765; CE-862 THRU CE-928; CJ-150 THRU CJ-155; D-10248 THRU
D-10353; EA-6 THRU EA-158
(Configuration 1)

Raytheon Aircraft

BEECH BONANZA WIRING DIAGRAM MANUAL

REFERENCE DESIGNATOR	PART NUMBER	DESCRIPTION	INSTL ZONE	USABLE ON CODE
24-30-03				
(Configuration 1)				
A16	36-380000-3	SENSOR-ALTERNATOR OUT	222	1
BT10	36-380059-1	BATTERY (ALTN FOR PS12-11)	222	1
BT10	PS12-11	BATTERY (ALTN FOR 36-380059-1)	222	1
B15	MHJ-4003	MOTOR-STARTER (ALTN FOR 637847)	410	1
B15	637847	MOTOR-STARTER (ALTN FOR MHJ-4003)	410	1
CR20	1.5KE51CA	TRANSZORB-START RELAY	222	1
CR24	1N4007	DIODE-BATTERY MASTER RELAY (SUPERSEDED BY 132408-22)	222	1
CR24	132408-22	DIODE-BATTERY MASTER RELAY (SUPERSEDES 1N4007)	222	1
CR25	1N4007	DIODE-BATTERY MASTER (SUPERSEDED BY 132408-22)	222	1
CR25	132408-22	DIODE-BATTERY MASTER (SUPERSEDES 1N4007)	222	1
C11	39D507G050GL4	CAPACITOR-ALTERNATOR (OPTL)	410	3
F1	FLLB	LIMITER-ELECTRIC, ALTERNATOR OUTPUT	222	1
F15	AGC5	FUSE-AMMETER	222	1
F16	AGC5	FUSE-AMMETER	222	1
F2	FLLA	LIMITER-ELECTRICAL BUS	222	1
F26	AGC5	FUSE-START ANNUNCIATOR (OPTL)	222	2
F3	FLLA	LIMITER-AVIONICS BUS	222	1
F31	AGC5	FUSE-ALTERNATOR AUXILIARY OUTPUT	410	1
GS3	131270-3	GROUND STUD-FIREWALL	221	1
GS4	AN3-5A	GROUND STUD-LOWER FIREWALL	222	1
G18	642056A2	ALTERNATOR, 100 AMP(W/ CLUTCH)(ALTN FOR ALV9407)	410	1
G18	641668	ALTERNATOR, 50 AMP (ALTN FOR ALT9422)	410	1
G18	ALT9422	ALTERNATOR, 50 AMP (ALTN FOR 641668)	410	1
G18	642056	ALTERNATOR, 100 AMP (WITHOUT CLUTCH)	410	1
G18	642056A2	ALTERNATOR, 100 AMP (WITH CLUTCH)	410	1
J80	204814-1	RECEPTACLE-GROUNDING BLOCK	231	1
K14	6041H190	RELAY-START	222	1
K15	6041H189	RELAY-BATTERY MASTER	222	1
P80A	200838-3	PLUG-GROUNDING BLOCK	231	1
P80B	201224-1	STRAIN RELIEF	231	1
P80C	201328-1	SOCKET CONTACT	231	1
P80D	200333-1	SOCKET CONTACT	231	1
P80E	203618-1	JACKSCREW	231	1
R34	MS91586-2	SHUNT-50 AMP	131	1
R34	MS91586-6	SHUNT-100 AMP (OPTL)	222	1
S29	35-380053-21	SWITCH-BATTERY	240	1
W11	002-369014-3	BUS BAR-ALTERNATOR (USED WITH 50 AMP ALTERNATOR)	410	1
W20	36-364001-27	BUS BAR-SHUNT, AVIONICS LIMITER	222	1
W22	002-361016-7	BUS BAR-SHUNT, ELECTRIC LIMITER	222	1
W24	36-364001-13	BUS BAR-START RELAY	222	1
W25	36-364001-19	BUS BAR-BATTERY MASTER	222	1
XF1	FSH	LIMITER BASE	222	1
XF15	4532	FUSEHOLDER-AMMETER/CLOCK	222	1
XF2	FSH	LIMITER BASE-ELECTRICAL BUS	222	1
XF26	60-369025-2	FUSEHOLDER-START ANNUNCIATOR LIGHT	222	2
XF3	FSH	LIMITER BASE-AVIONICS BUS	222	1

Raytheon Aircraft

BEECH BONANZA WIRING DIAGRAM MANUAL

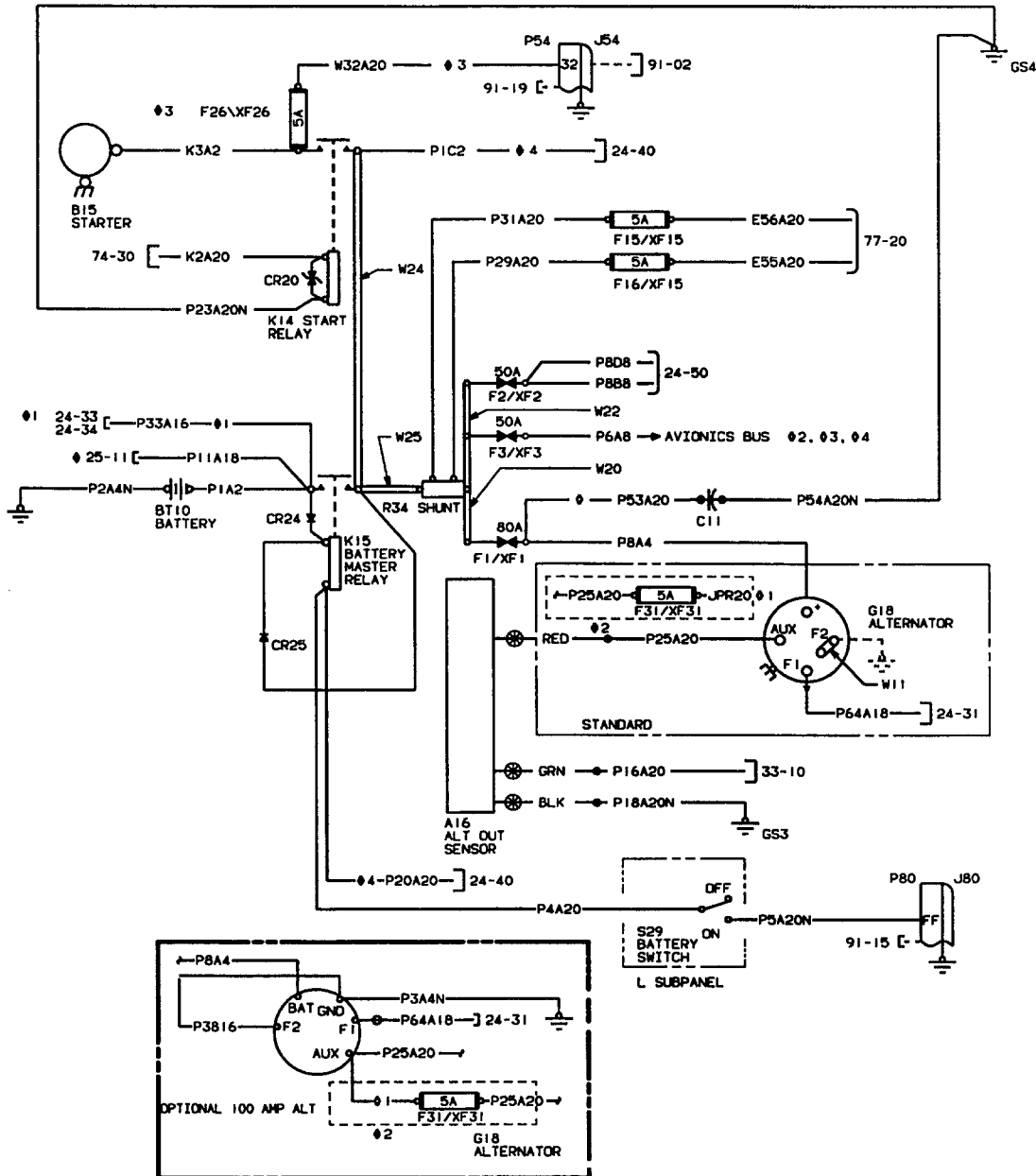

- ⦿2 REFER TO APPLICABLE AVIONICS DIAG FOR MODE OF CONNECTION.
- ⦿3 WHEN OPTIONAL DUAL NAV IS USED REFER TO DIAG 24-51.
- ⦿4 WHEN OPTIONAL SINGLE NAV IS USED REFER TO DIAG 24-52.
- ⦿4 USED ON ACFT WITH EXTERNAL POWER OPTION
- ⦿3 USED ON ACFT CE-919, CE-923, CE-925 & CE-927 ONLY
- ⦿2 WIRE AS SHOWN EA-158 ONLY
- ⦿1 ON ACFT EA-6 & AFT NOT USED
- ⦿ ON ACFT HAVING OPTIONAL CONTROL WHEEL CLOCK INSTALLED, REF DIAGRAM 25-12 REPLACES REF DIAGRAM 25-11.
- ⦿1 WIRE LENGTH MUST BE KEPT LESS THAN 3-INCHES.
- ⦿ WIRE LENGTH MUST BE KEPT LESS THAN 6-INCHES.

CE24F
982522AA

ALTERNATOR (PRIOR TO INSTALLATION OF KIT 55-3025-1S)
E-1519 THRU E-1765; CE-862 THRU CE-928; CJ-150 THRU CJ-155; D-10248 THRU
D-10353; EA-6 THRU EA-158
(Configuration 1)

Raytheon Aircraft

BEECH BONANZA WIRING DIAGRAM MANUAL

REFERENCE DESIGNATOR	PART NUMBER	DESCRIPTION	INSTL ZONE	USABLE ON CODE
		24-30-03 (Configuration 1)		
XF31	HDJ-A	FUSEHOLDER-ALTERNATOR AUXILIARY OUTPUT (ALTN FOR HHJ-A)	410	1
XF31	HHJ-A	FUSEHOLDER-ALTERNATOR AUXILIARY OUTPUT (ALTN FOR HDJ-A)	410	1

NOTE

REFER TO THE ALTERNATOR (G18)
INSTALLED IN THE AIRPLANE FOR THE
CORRECT PART NUMBER.

CODES OF EFFECTIVITY

1. E-1519 THRU E-1765; CE-862 THRU CE-928; CJ-150 THRU CJ-155; D-10248 THRU D-10353; EA-6 THRU EA-158 (PRIOR TO INSTALLATION OF KIT 55-3025-1S)
2. CE-919, CE-923, CE-925 AND CE-927 (PRIOR TO INSTALLATION OF KIT 55-3025-1S)
3. E-1519 THRU E-1765; CE-862 THRU CE-928; D-10248 THRU D-10353; EA-6 THRU EA-158 (PRIOR TO INSTALLATION OF KIT 55-3025-1S)

Raytheon Aircraft

BEECH BONANZA WIRING DIAGRAM MANUAL

24-30-03

ALTERNATOR (AFTER INSTALLATION OF KIT 55-3025-1S)

(Configuration 2)

**E-1519 THRU E-1765; CE-862 THRU CE-928; CJ-150 THRU CJ-155; D-10248 THRU D-10353; EA-6 THRU
EA-158**

Raytheon Aircraft

BEECH BONANZA WIRING DIAGRAM MANUAL

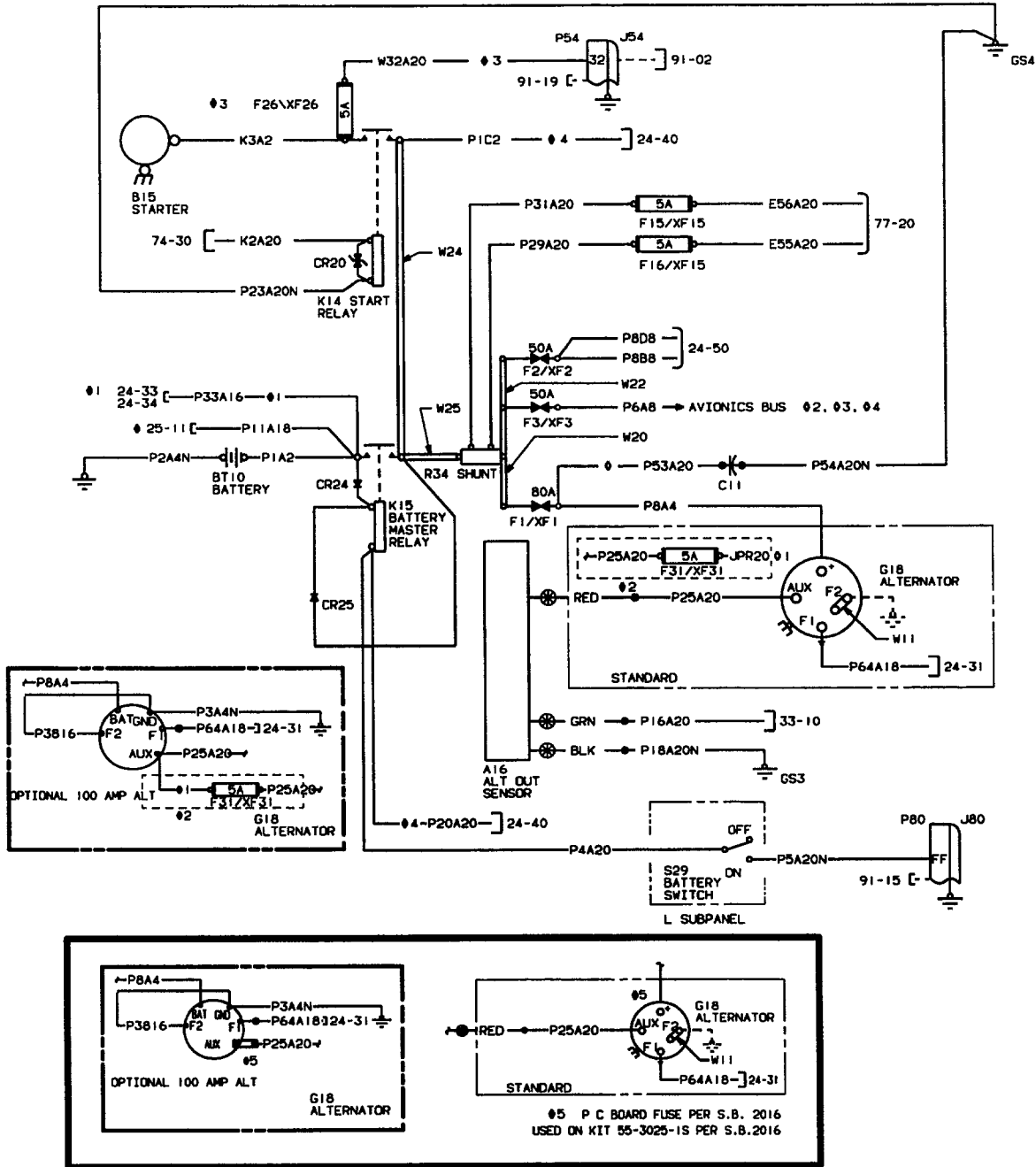

ALTERNATOR (AFTER INSTALLATION OF KIT 55-3025-1S)
E-1519 THRU E-1765; CE-862 THRU CE-928; CJ-150 THRU CJ-155; D-10248 THRU
D-10353; EA-6 THRU EA-158
(Configuration 2)

Raytheon Aircraft

BEECH BONANZA WIRING DIAGRAM MANUAL

REFERENCE DESIGNATOR	PART NUMBER	DESCRIPTION	INSTL ZONE	USABLE ON CODE
24-30-03				
(Configuration 2)				
A16	36-380000-3	SENSOR-ALTERNATOR OUT	222	1
BT10	36-380059-1	BATTERY (ALTN FOR PS12-11)	222	1
BT10	PS12-11	BATTERY (ALTN FOR 36-380059-1)	222	1
B15	MHJ-4003	MOTOR-STARTER (ALTN FOR 637847)	410	1
B15	637847	MOTOR-STARTER (ALTN FOR MHJ-4003)	410	1
CR20	1.5KE51CA	TRANSZORB-START RELAY	222	1
CR24	1N4007	DIODE-BATTERY MASTER RELAY (SUPERSEDED BY 132408-22)	222	1
CR24	132408-22	DIODE-BATTERY MASTER RELAY (SUPERSEDES 1N4007)	222	1
CR25	1N4007	DIODE-BATTERY MASTER (SUPERSEDED BY 132408-22)	222	1
CR25	132408-22	DIODE-BATTERY MASTER (SUPERSEDES 1N4007)	222	1
C11	39D507G050GL4	CAPACITOR-ALTERNATOR (OPTL)	410	3
F1	FLLB	LIMITER-ELECTRIC, ALTERNATOR OUTPUT	222	1
F15	AGC5	FUSE-AMMETER	222	1
F16	AGC5	FUSE-AMMETER	222	1
F2	FLLA	LIMITER-ELECTRICAL BUS	222	1
F26	AGC5	FUSE-START ANNUNCIATOR (OPTL)	222	2
F3	FLLA	LIMITER-AVIONICS BUS	222	1
F31	AGC5	FUSE-ALTERNATOR AUXILIARY OUTPUT	410	1
GS3	131270-3	GROUND STUD-FIREWALL	221	1
GS4	AN3-5A	GROUND STUD-LOWER FIREWALL	222	1
G18	642056A2	ALTERNATOR, 100 AMP(W/ CLUTCH)(ALTN FOR ALV9407)	410	1
G18	641668	ALTERNATOR, 50 AMP (ALTN FOR ALT9422)	410	1
G18	ALT9422	ALTERNATOR, 50 AMP (ALTN FOR 641668)	410	1
G18	642056	ALTERNATOR, 100 AMP (WITHOUT CLUTCH)	410	1
G18	642056A2	ALTERNATOR, 100 AMP (WITH CLUTCH)	410	1
J80	204814-1	RECEPTACLE-GROUNDING BLOCK	231	1
K14	6041H190	RELAY-START	222	1
K15	6041H189	RELAY-BATTERY MASTER	222	1
P80A	200838-3	PLUG-GROUNDING BLOCK	231	1
P80B	201224-1	STRAIN RELIEF	231	1
P80C	201328-1	SOCKET CONTACT	231	1
P80D	200333-1	SOCKET CONTACT	231	1
P80E	203618-1	JACKSCREW	231	1
R34	MS91586-2	SHUNT-50 AMP	131	1
R34	MS91586-6	SHUNT-100 AMP (OPTL)	222	1
S29	35-380053-21	SWITCH-BATTERY	240	1
W11	002-369014-3	BUS BAR-ALTERNATOR (USED WITH 50 AMP ALTERNATOR)	410	1
W20	36-364001-27	BUS BAR-SHUNT, AVIONICS LIMITER	222	1
W22	002-361016-7	BUS BAR-SHUNT, ELECTRIC LIMITER	222	1
W24	36-364001-13	BUS BAR-START RELAY	222	1
W25	36-364001-19	BUS BAR-BATTERY MASTER	222	1
XF1	FSH	LIMITER BASE	222	1
XF15	4532	FUSEHOLDER-AMMETER/CLOCK	222	1
XF2	FSH	LIMITER BASE-ELECTRICAL BUS	222	1
XF26	60-369025-2	FUSEHOLDER-START ANNUNCIATOR LIGHT	222	2
XF3	FSH	LIMITER BASE-AVIONICS BUS	222	1

Raytheon Aircraft

BEECH BONANZA WIRING DIAGRAM MANUAL

REFERENCE DESIGNATOR	PART NUMBER	DESCRIPTION	INSTL ZONE	USABLE ON CODE
24-30-03 (Configuration 2)				
XF31	HDJ-A	FUSEHOLDER-ALTERNATOR AUXILIARY OUTPUT (ALTN FOR HHJ-A)	410	1
XF31	HHJ-A	FUSEHOLDER-ALTERNATOR AUXILIARY OUTPUT (ALTN FOR HDJ-A)	410	1
Y1A		THE FOLLOWING COMPONENTS ARE PART OF KIT 55-3025-1S AND COMPLY WITH S.B. 2016.		
Y1B	55-3025-1S	KIT, PRINTED CIRCUIT BOARD FUSE ASSEMBLY (CONSISTS OF PARTS AND INSTRUCTIONS TO INSTALL A PRINTED CIRCUIT BOARD FUSE DIRECTLY ON THE AUXILIARY OUTPUT TERMINAL OF THE ALTERNATOR)		1
Y1C	58-360006-1	ALTERNATOR CONTROL RESISTOR ASSEMBLY-ALTERNATOR FUSE (A COMPONENT PART OF KIT 55-3025-1S) (SUPERSEDES 58-361014-1)		1
Y1D	58-361015-1	PRINTED CIRCUIT BOARD (A COMPONENT PART OF KIT 55-3025-1S)		1
Y1E	WF2K10R	RESISTOR, FUSIBLE (A COMPONENT PART OF KIT 55-3025-1S)		1
Y1F	9505-08	NUTSERT (A COMPONENT PART OF KIT 55-3025-1S)		1

NOTE

REFER TO THE ALTERNATOR (G18)
INSTALLED IN THE AIRPLANE FOR THE
CORRECT PART NUMBER.

CODES OF EFFECTIVITY

1. E-1519 THRU E-1765; CE-862 THRU CE-928; CJ-150 THRU CJ-155; D-10248 THRU D-10353; EA-6 THRU EA-158 (AFTER INSTALLATION OF KIT 55-3025-1S)
2. CE-919, CE-923, CE-925 AND CE-927 (AFTER INSTALLATION OF KIT 55-3025-1S)
3. E-1519 THRU E-1765; CE-862 THRU CE-928; D-10248 THRU D-10353; EA-6 THRU EA-158 (AFTER INSTALLATION OF KIT 55-3025-1S)

Raytheon Aircraft

BEECH BONANZA WIRING DIAGRAM MANUAL

24-30-04

ALTERNATOR (PRIOR TO INSTALLATION OF KIT 55-3025-1S)

(Configuration 1)

**E-1766 THRU E-1945, E-1947 THRU E-2103, E-2105 THRU E-2110; CE-929 THRU CE-1028; D-10354 AND
AFTER; EA-159 THRU EA-319, EA-321 THRU EA-388**

Raytheon Aircraft

BEECH BONANZA WIRING DIAGRAM MANUAL

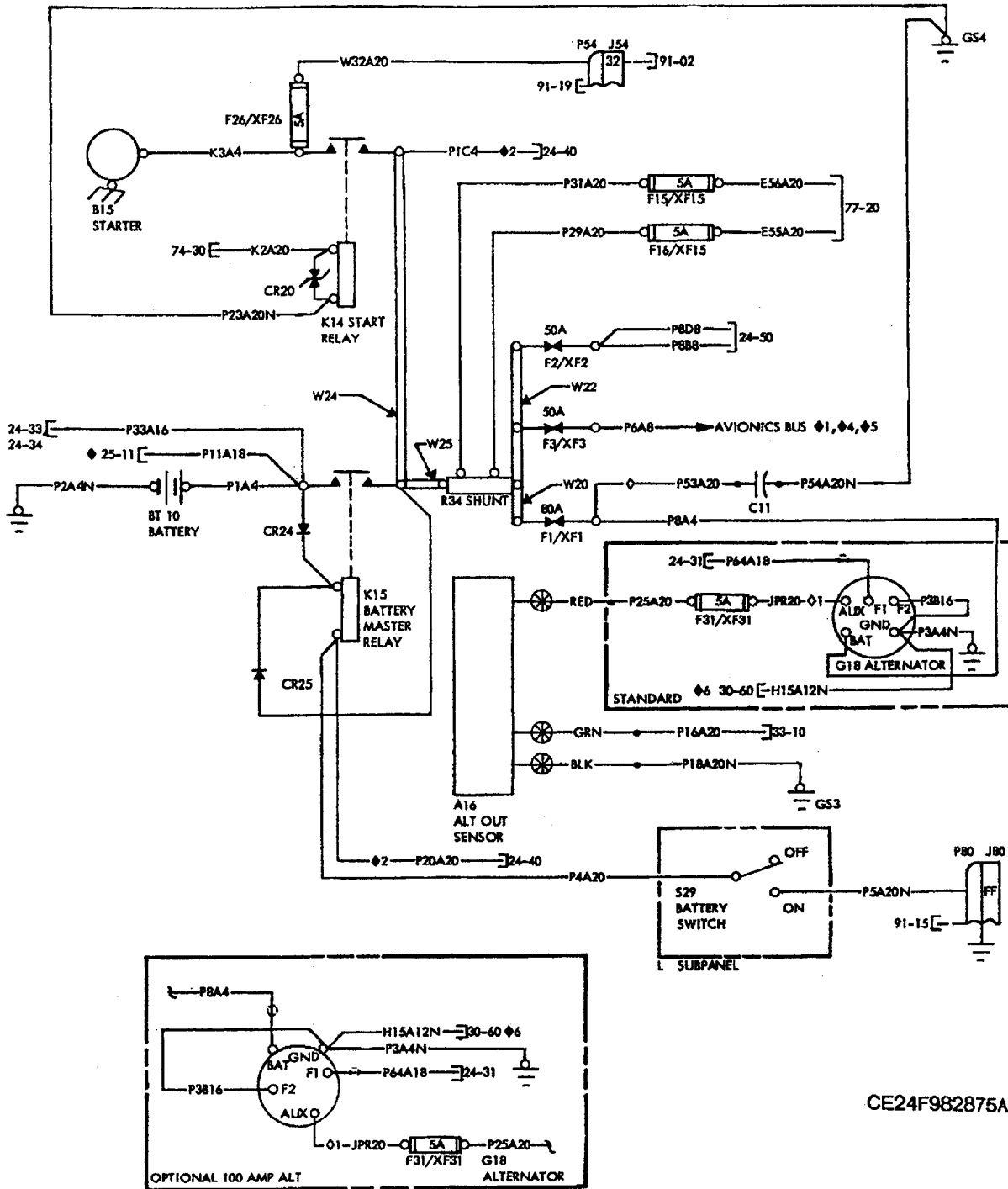

CE24F982875AA

- ◆6 ON AIRCRAFT WITH PROP ANTI-ICE OPTION
- ◆5 WHEN OPTIONAL SINGLE NAV IS USED REFER TO DIAG 24-52
- ◆4 WHEN OPTIONAL DUAL NAV IS USED REFER TO DIAG 24-51
- ◆2 ON ACFT WITH EXTERNAL POWER OPTION
- ◆1 REFER TO APPLICABLE AVIONICS DIAG FOR MODE OF CONNECTION

- ◆ ON ACFT HAVING OPTIONAL CONTROL WHEEL CLOCK INSTALLED, REF DIAGRAM 25-12 REPLACES REF DIAGRAM 25-11

- 1 WIRE LENGTH MUST BE KEPT LESS THAN 3-INCHES
- ◇ WIRE LENGTH MUST BE KEPT LESS THAN 6-INCHES.

ALTERNATOR (PRIOR TO INSTALLATION OF KIT 55-3025-1S)
E-1766 THRU E-1945, E-1947 THRU E-2103, E-2105 THRU E-2110; CE-929 THRU
CE-1028; D-10354 AND AFTER; EA-159 THRU EA-319, EA-321 THRU EA-388
(Configuration 1)

Raytheon Aircraft

BEECH BONANZA WIRING DIAGRAM MANUAL

REFERENCE DESIGNATOR	PART NUMBER	DESCRIPTION	INSTL ZONE	USABLE ON CODE
24-30-04				
(Configuration 1)				
A16	36-380000-3	SENSOR-ALTERNATOR OUT	222	1
BT10	PS12-11	BATTERY (ALTN FOR 36-380059-1)	222	1
BT10	36-380059-1	BATTERY (ALTN FOR PS12-11)	222	1
B15	637847	STARTER (ALTN FOR MHJ-4003)	222	1
B15	MHJ-4003	STARTER (ALTN FOR 637847)	222	1
CR20	1.5KE51CA	TRANSZORB	222	1
CR24	1N4007	DIODE (SUPERSEDED BY 132408-22)	222	1
CR24	132408-22	DIODE (SUPERSEDES 1N4007)	222	1
CR25	1N4007	DIODE (SUPERSEDED BY 132408-22)	222	1
CR25	132408-22	DIODE (SUPERSEDES 1N4007)	222	1
C11	39D507G050GL4	CAPACITOR-ALTERNATOR (OPTL)	410	1
F1	FLLB	LIMITER-ELECTRIC, ALTERNATOR OUTPUT	222	1
F15	AGC5	FUSE-AMMETER	222	1
F16	AGC5	FUSE-AMMETER	222	1
F2	FLLA	LIMITER-ELECTRICAL BUS	222	1
F26	AGC5	FUSE-START ANNUNCIATOR (OPTL)	222	1
F3	FLLA	LIMITER-AVIONICS BUS	222	1
F31	AGC5	FUSE-ALTERNATOR AUXILIARY OUTPUT	410	1
GS3	131270-3	GROUND STUD-FIREWALL	221	1
GS4	AN3-5A	GROUND STUD-LOWER FIREWALL	222	1
G18	642055	ALTERNATOR, 60 AMP	410	2
G18	646490-A1	ALTERNATOR, 60 AMP	410	4
G18	646491-A1	ALTERNATOR, 100 AMP (OPTL)	410	4
G18	642056A2	ALTERNATOR, 100 AMP (OPTL)	410	3
G18	646845	ALTERNATOR, 60 AMP (OPTL)	410	1
J54A	206151-2	RECEPTACLE-JUNCTION BOX ASSEMBLY	231	1
J54B	206138-1	STRAIN RELIEF	231	1
J54C	66103-2	PIN CONTACT	231	1
J80	204814-1	RECEPTACLE-GROUNDING BLOCK	231	1
K14	6041H190	RELAY-START	222	1
K15	6041H189	RELAY-BATTERY MASTER	222	1
P54A	206150-1	PLUG-JUNCTION BOX ASSEMBLY	231	1
P54B	206138-1	STRAIN RELIEF	231	1
P54C	66105-2	SOCKET CONTACT	231	1
P80A	200838-3	PLUG-GROUNDING BLOCK	231	1
P80B	201224-1	STRAIN RELIEF	231	1
P80C	201328-1	SOCKET CONTACT	231	1
P80D	200333-1	SOCKET CONTACT	231	1
P80E	203618-1	JACKSCREW	231	1
R34	MS91586-6	SHUNT-100 AMP (OPTL)	222	1
R34	MLA-60-50	SHUNT-60 AMP	131	1
S29	35-380053-21	SWITCH-BATTERY	240	1
W20	36-364001-27	BUS BAR-ALTERNATOR LIMITER	222	1
W22	002-361016-7	BUS BAR-LIMITER	222	1
W24	36-364001-13	BUS BAR-STARTER RELAY	222	1
W25	36-364001-19	BUS BAR-BATTERY MASTER	222	1
XF1	FSH	LIMITER BASE-ALTERNATOR	222	1
XF15	4532	FUSEHOLDER-AMMETER/CLOCK	222	1
XF2	FSH	LIMITER BASE-ELECTRIC BUS	222	1
XF26	60-369025-2	FUSEHOLDER-START ANNUNCIATOR LIGHT	222	1
XF3	FSH	LIMITER BASE-AVIONICS BUS	222	1

Raytheon Aircraft

BEECH BONANZA WIRING DIAGRAM MANUAL

REFERENCE DESIGNATOR	PART NUMBER	DESCRIPTION	INSTL ZONE	USABLE ON CODE
		24-30-04 (Configuration 1)		
XF31	HDJ-A	FUSEHOLDER-ALTERNATOR AUXILIARY OUTPUT (ALTN FOR HHJ-A)	410	1
XF31	HHJ-A	FUSEHOLDER-ALTERNATOR AUXILIARY OUTPUT (ALTN FOR HDJ-A)	410	1

NOTE

REFER TO THE ALTERNATOR (G18)
INSTALLED IN THE AIRPLANE FOR THE
CORRECT PART NUMBER.

CODES OF EFFECTIVITY

1. E-1766 THRU E-1945, E-1947 THRU E-2103, E-2105 THRU E-2110; CE-929 THRU CE-1028; D-10354 AND AFTER; EA-159 THRU EA-319, EA-321 THRU EA-388 (PRIOR TO INSTALLATION OF KIT 55-3025-1S)
2. E-1766 THRU E-1945, E-1947 THRU E-2103, E-2105 THRU E-2110; CE-929 THRU CE-1025; D-10354 AND AFTER; EA-159 THRU EA-319, EA-321 THRU EA-388 (PRIOR TO INSTALLATION OF KIT 55-3025-1S)
3. E-1766 THRU E-1945, E-1947 THRU E-2103, E-2105 THRU E-2110; CE-929 THRU CE-1025; D-10354 AND AFTER; EA-6 THRU EA-319, EA-321 THRU EA-388 (PRIOR TO INSTALLATION OF KIT 55-3025-1S)
4. CE-1026 THRU CE-1028 (PRIOR TO INSTALLATION OF KIT 55-3025-1S)

Raytheon Aircraft

BEECH BONANZA WIRING DIAGRAM MANUAL

24-30-04

ALTERNATOR (AFTER INSTALLATION OF KIT 55-3025-1S)

(Configuration 2)

**E-1766 THRU E-1945, E-1947 THRU E-2103, E-2105 THRU E-2110; CE-929 THRU CE-1028; D-10354 AND
AFTER; EA-159 THRU EA-319, EA-321 THRU EA-323**

Raytheon Aircraft

BEECH BONANZA WIRING DIAGRAM MANUAL

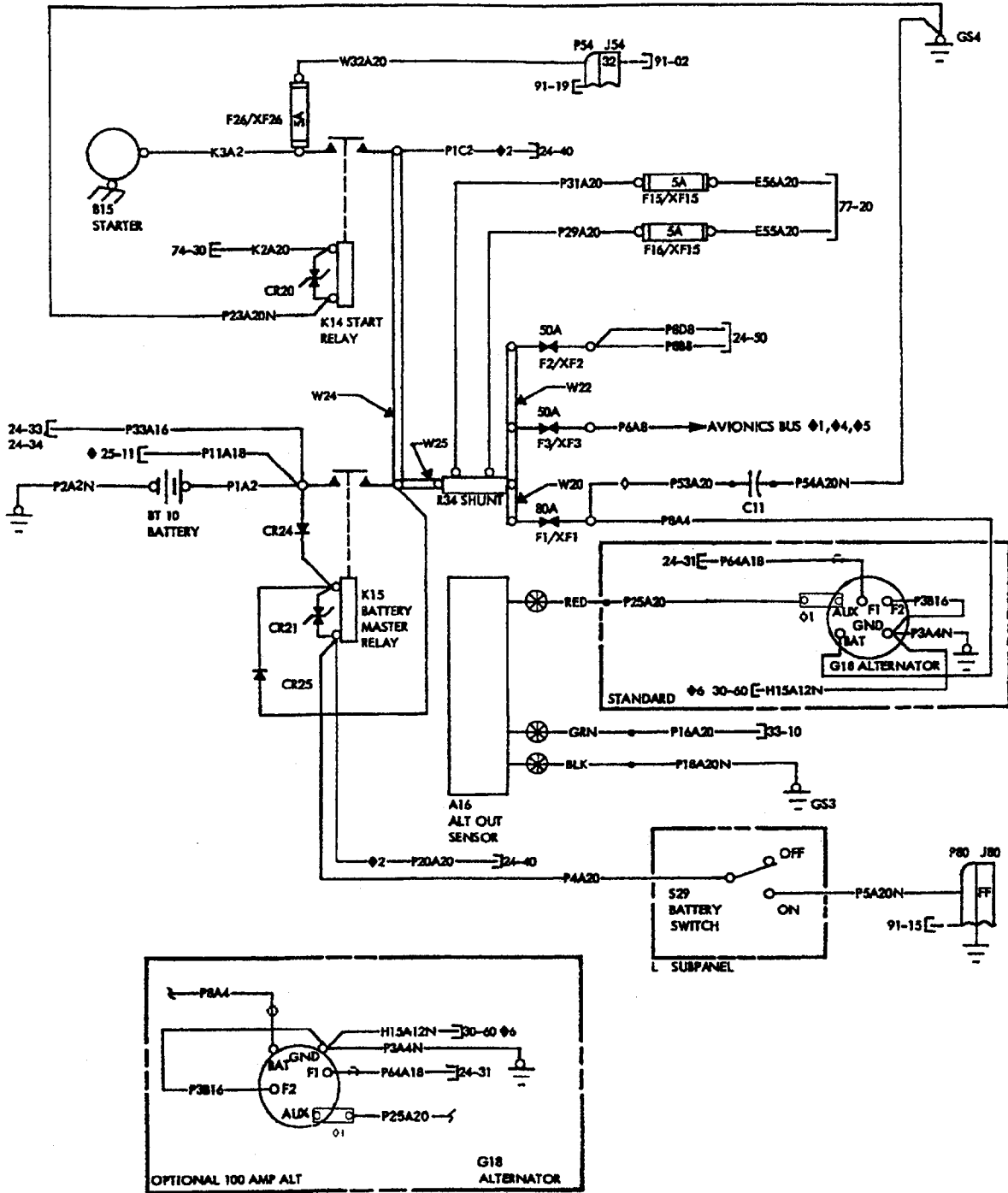

- ◆6 ON AIRCRAFT WITH PROP ANTI-ICE OPTION
- ◆5 WHEN OPTIONAL SINGLE NAV IS USED REFER TO DIAG 24-52
- ◆4 WHEN OPTIONAL DUAL NAV IS USED REFER TO DIAG 24-51
- ◆2 ON ACFT WITH EXTERNAL POWER OPTION
- ◆1 REFER TO APPLICABLE AVIONICS DIAG FOR MODE OF CONNECTION

- ◆ ON ACFT HAVING OPTIONAL CONTROL WHEEL CLOCK INSTALLED, REF DIAGRAM 25-12 REPLACES REF DIAGRAM 25-11

- ◇1 PC BOARD FUSE PER S.B. 2016.
- ◇ WIRE LENGTH MUST BE KEPT LESS THAN 6-INCHES.

CE24F982876AA

ALTERNATOR (AFTER INSTALLATION OF KIT 55-3025-1S)
E-1766 THRU E-1945, E-1947 THRU E-2103, E-2105 THRU E-2110; CE-929 THRU
CE-1028; D-10354 AND AFTER; EA-159 THRU EA-319, EA-321 THRU EA-323
(Configuration 2)

Raytheon Aircraft

BEECH BONANZA WIRING DIAGRAM MANUAL

REFERENCE DESIGNATOR	PART NUMBER	DESCRIPTION	INSTL ZONE	USABLE ON CODE
24-30-04				
(Configuration 2)				
A16	36-380000-3	SENSOR-ALTERNATOR OUT	222	1
BT10	PS12-11	BATTERY (ALTN FOR 36-380059-1)	222	1
BT10	36-380059-1	BATTERY (ALTN FOR PS12-11)	222	1
B15	637847	STARTER (ALTN FOR MHJ-4003)	222	1
B15	MHJ-4003	STARTER (ALTN FOR 637847)	222	1
CR20	1.5KE51CA	TRANSZORB	222	1
CR21	1.5KE51CA	TRANSZORB-BATTERY MASTER RELAY	222	1
CR24	1N4007	DIODE (SUPERSEDED BY 132408-22)	222	1
CR24	132408-22	DIODE (SUPERSEDES 1N4007)	222	1
CR25	1N4007	DIODE (SUPERSEDED BY 132408-22)	222	1
CR25	132408-22	DIODE (SUPERSEDES 1N4007)	222	1
C11	39D507G050GL4	CAPACITOR-ALTERNATOR (OPTL)	410	1
F1	FLLB	LIMITER-ELECTRIC, ALTERNATOR OUTPUT	222	1
F15	AGC5	FUSE-AMMETER	222	1
F16	AGC5	FUSE-AMMETER	222	1
F2	FLLA	LIMITER-ELECTRICAL BUS	222	1
F26	AGC5	FUSE-START ANNUNCIATOR (OPTL)	222	1
F3	FLLA	LIMITER-AVIONICS BUS	222	1
GS3	131270-3	GROUND STUD-FIREWALL	221	1
GS4	AN3-5A	GROUND STUD-LOWER FIREWALL	222	1
G18	646490-A1	ALTERNATOR, 60 AMP	410	1
G18	646491-A1	ALTERNATOR, 100 AMP (OPTL)	410	1
J54A	206151-2	RECEPTACLE-JUNCTION BOX ASSEMBLY	231	1
J54B	206138-1	STRAIN RELIEF	231	1
J54C	66103-2	PIN CONTACT	231	1
J80	204814-1	RECEPTACLE-GROUNDING BLOCK	231	1
K14	6041H190	RELAY-START	222	1
K15	6041H189	RELAY-BATTERY MASTER	222	1
P54A	206150-1	PLUG-JUNCTION BOX ASSEMBLY	231	1
P54B	206138-1	STRAIN RELIEF	231	1
P54C	66105-2	SOCKET CONTACT	231	1
P80A	200838-3	PLUG-GROUNDING BLOCK	231	1
P80B	201224-1	STRAIN RELIEF	231	1
P80C	201328-1	SOCKET CONTACT	231	1
P80D	200333-1	SOCKET CONTACT	231	1
P80E	203618-1	JACKSCREW	231	1
R34	MS91586-6	SHUNT-100 AMP (OPTL)	222	1
R34	MLA-60-50	SHUNT-60 AMP	131	1
S29	35-380053-21	SWITCH-BATTERY	240	1
W20	36-364001-27	BUS BAR-ALTERNATOR LIMITER	222	1
W22	002-361016-7	BUS BAR-LIMITER	222	1
W24	36-364001-13	BUS BAR-STARTER RELAY	222	1
W25	36-364001-19	BUS BAR-BATTERY MASTER	222	1
XF1	FSH	LIMITER BASE-ALTERNATOR	222	1
XF15	4532	FUSEHOLDER-AMMETER/CLOCK	222	1
XF2	FSH	LIMITER BASE-ELECTRIC BUS	222	1
XF26	60-369025-2	FUSEHOLDER-START ANNUNCIATOR LIGHT	222	1
XF3	FSH	LIMITER BASE-AVIONICS BUS	222	1
Y1A		THE FOLLOWING COMPONENTS ARE PART OF KIT 55-3025-1S AND COMPLY WITH S.B. 2016.		

Raytheon Aircraft

BEECH BONANZA WIRING DIAGRAM MANUAL

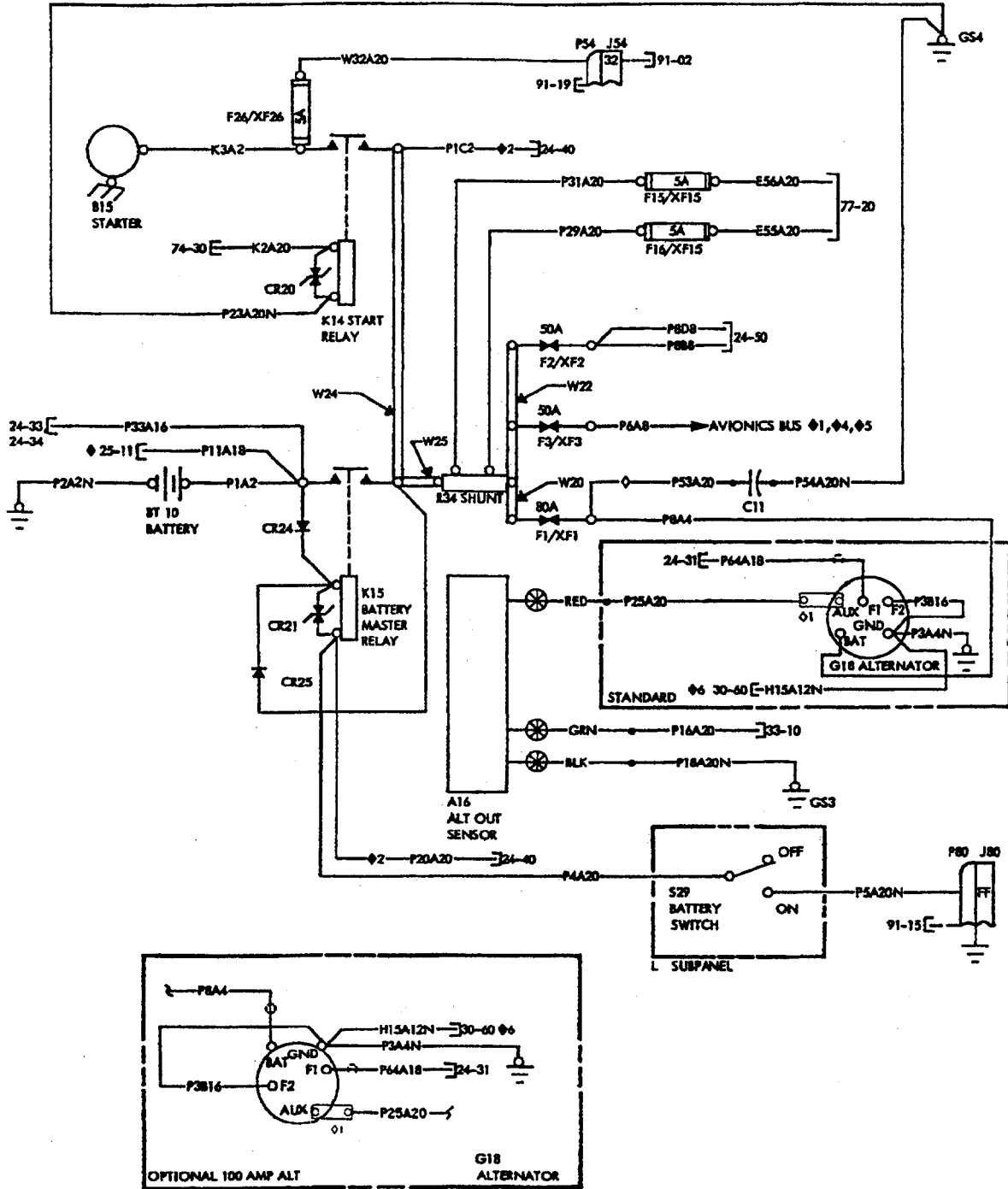

- ◆6 ON AIRCRAFT WITH PROP ANTI-ICE OPTION
- ◆5 WHEN OPTIONAL SINGLE NAV IS USED REFER TO DIAG 24-52
- ◆4 WHEN OPTIONAL DUAL NAV IS USED REFER TO DIAG 24-51
- ◆2 ON ACFT WITH EXTERNAL POWER OPTION
- ◆1 REFER TO APPLICABLE AVIONICS DIAG FOR MODE OF CONNECTION

- ◆ ON ACFT HAVING OPTIONAL CONTROL WHEEL CLOCK INSTALLED, REF DIAGRAM 25-12 REPLACES REF DIAGRAM 25-11

- ◆1 PC BOARD FUSE PER S.B. 2016
- ◆ WIRE LENGTH MUST BE KEPT LESS THAN 6-INCHES.

CE24F982876AA

ALTERNATOR (AFTER INSTALLATION OF KIT 55-3025-1S)
 E-1766 THRU E-1945, E-1947 THRU E-2103, E-2105 THRU E-2110; CE-929 THRU
 CE-1028; D-10354 AND AFTER; EA-159 THRU EA-319, EA-321 THRU EA-323
 (Configuration 2)

Raytheon Aircraft

BEECH BONANZA WIRING DIAGRAM MANUAL

REFERENCE DESIGNATOR	PART NUMBER	DESCRIPTION	INSTL ZONE	USABLE ON CODE
24-30-04 (Configuration 2)				
Y1B	55-3025-1S	KIT, PRINTED CIRCUIT BOARD FUSE ASSEMBLY (CONSISTS OF PARTS AND INSTRUCTIONS TO INSTALL A PRINTED CIRCUIT BOARD FUSE DIRECTLY ON THE AUXILIARY OUTPUT TERMINAL OF THE ALTERNATOR)		2
Y1C	58-360006-1	ALTERNATOR CONTROL RESISTOR ASSEMBLY-ALTERNATOR FUSE (A COMPONENT PART OF KIT 55-3025-1S) (SUPERSEDES 58-361014-1)		2
Y1D	58-361015-1	PRINTED CIRCUIT BOARD (A COMPONENT PART OF KIT 55-3025-1S)		2
Y1E	WF2K10R	RESISTOR, FUSIBLE (A COMPONENT PART OF KIT 55-3025-1S)		2
Y1F	9505-08	NUTSERT (A COMPONENT PART OF KIT 55-3025-1S)		2

NOTE

REFER TO THE ALTERNATOR (G18)
INSTALLED IN THE AIRPLANE FOR THE
CORRECT PART NUMBER.

CODES OF EFFECTIVITY

1. E-1766 THRU E-1945, E-1947 THRU E-2103, E-2105 THRU E-2110; CE-929 THRU CE-1028; D-10354 AND AFTER; EA-159 THRU EA-319, EA-321 THRU EA-323 (AFTER INSTALLATION OF KIT 55-3025-1S)
2. E-1766 THRU E-1945, E-1947 THRU E-2049; CE-929 THRU CE-1028; D-10354 THRU D-10403; EA-159 THRU EA-319, EA-321 THRU EA-323 (AFTER INSTALLATION OF KIT 55-3025-1S)

Raytheon Aircraft

BEECH BONANZA WIRING DIAGRAM MANUAL

24-30-04

ALTERNATOR

(Configuration 3)

CE-1029 THRU CE-1791; CJ-156 THRU CJ-179

Raytheon Aircraft

BEECH BONANZA WIRING DIAGRAM MANUAL

REFERENCE DESIGNATOR	PART NUMBER	DESCRIPTION	INSTL ZONE	USABLE ON CODE
24-30-04				
(Configuration 3)				
A16	36-380000-3	SENSOR-ALTERNATOR OUT	222	1
BT10	PS12-11	BATTERY (ALTN FOR 36-380059-1)	222	1
BT10	36-380059-1	BATTERY (ALTN FOR PS12-11)	222	1
B15	637847	STARTER (ALTN FOR MHJ-4003)	222	1
B15	MHJ-4003	STARTER (ALTN FOR 637847)	222	1
CR20	1.5KE51CA	TRANSZORB	222	1
CR24	1N4007	DIODE (SUPERSEDED BY 132408-22)	222	1
CR24	132408-22	DIODE (SUPERSEDES 1N4007)	222	1
CR25	1N4007	DIODE (SUPERSEDED BY 132408-22)	222	1
CR25	132408-22	DIODE (SUPERSEDES 1N4007)	222	1
C11	39D507G050GL4	CAPACITOR-ALTERNATOR (OPTL)	410	1
F1	FLLB	LIMITER-ELECTRIC, ALTERNATOR OUTPUT	222	1
F15	AGC5	FUSE-AMMETER	222	1
F16	AGC5	FUSE-AMMETER	222	1
F2	FLLA	LIMITER-ELECTRICAL BUS	222	1
F26	AGC5	FUSE-START ANNUNCIATOR (OPTL)	222	1
F3	FLLA	LIMITER-AVIONICS BUS	222	1
F32	BW20F(1056)	FUSIBLE RESISTOR	410	1
GS3	131270-3	GROUND STUD-FIREWALL	221	1
GS4	AN3-5A	GROUND STUD-LOWER FIREWALL	222	1
G18	646490-A1	ALTERNATOR, 60 AMP	410	1
G18	646491-A1	ALTERNATOR, 100 AMP (OPTL)	410	1
J54A	206151-2	RECEPTACLE-JUNCTION BOX ASSEMBLY	231	1
J54B	206138-1	STRAIN RELIEF	231	1
J54C	66103-2	PIN CONTACT	231	1
K14	6041H190	RELAY-START	222	1
K15	6041H189	RELAY-BATTERY MASTER	222	1
P54A	206150-1	PLUG-JUNCTION BOX ASSEMBLY	231	1
P54B	206138-1	STRAIN RELIEF	231	1
P54C	66105-2	SOCKET CONTACT	231	1
P80A	200838-3	PLUG-GROUNDING BLOCK	231	1
P80B	201224-1	STRAIN RELIEF	231	1
P80C	201328-1	SOCKET CONTACT	231	1
P80D	200333-1	SOCKET CONTACT	231	1
P80E	203618-1	JACKSCREW	231	1
R34	MS91586-6	SHUNT-100 AMP (OPTL)	222	1
R34	MLA-60-50	SHUNT-60 AMP	131	1
S29	35-380053-21	SWITCH-BATTERY	240	1
W20	36-364001-27	BUS BAR-ALTERNATOR LIMITER	222	1
W22	002-361016-7	BUS BAR-LIMITER	222	1
W24	36-364001-13	BUS BAR-STARTER RELAY	222	1
W25	36-364001-19	BUS BAR-BATTERY MASTER	222	1
XF1	FSH	LIMITER BASE-ALTERNATOR	222	1
XF15	4532	FUSEHOLDER-AMMETER/CLOCK	222	1
XF2	FSH	LIMITER BASE-ELECTRIC BUS	222	1
XF26	60-369025-2	FUSEHOLDER-START ANNUNCIATOR LIGHT	222	1
XF3	FSH	LIMITER BASE-AVIONICS BUS	222	1
XF32	58-361015	FUSEHOLDER-PRINTED CIRCUIT BOARD	410	1

Raytheon Aircraft

BEECH BONANZA WIRING DIAGRAM MANUAL

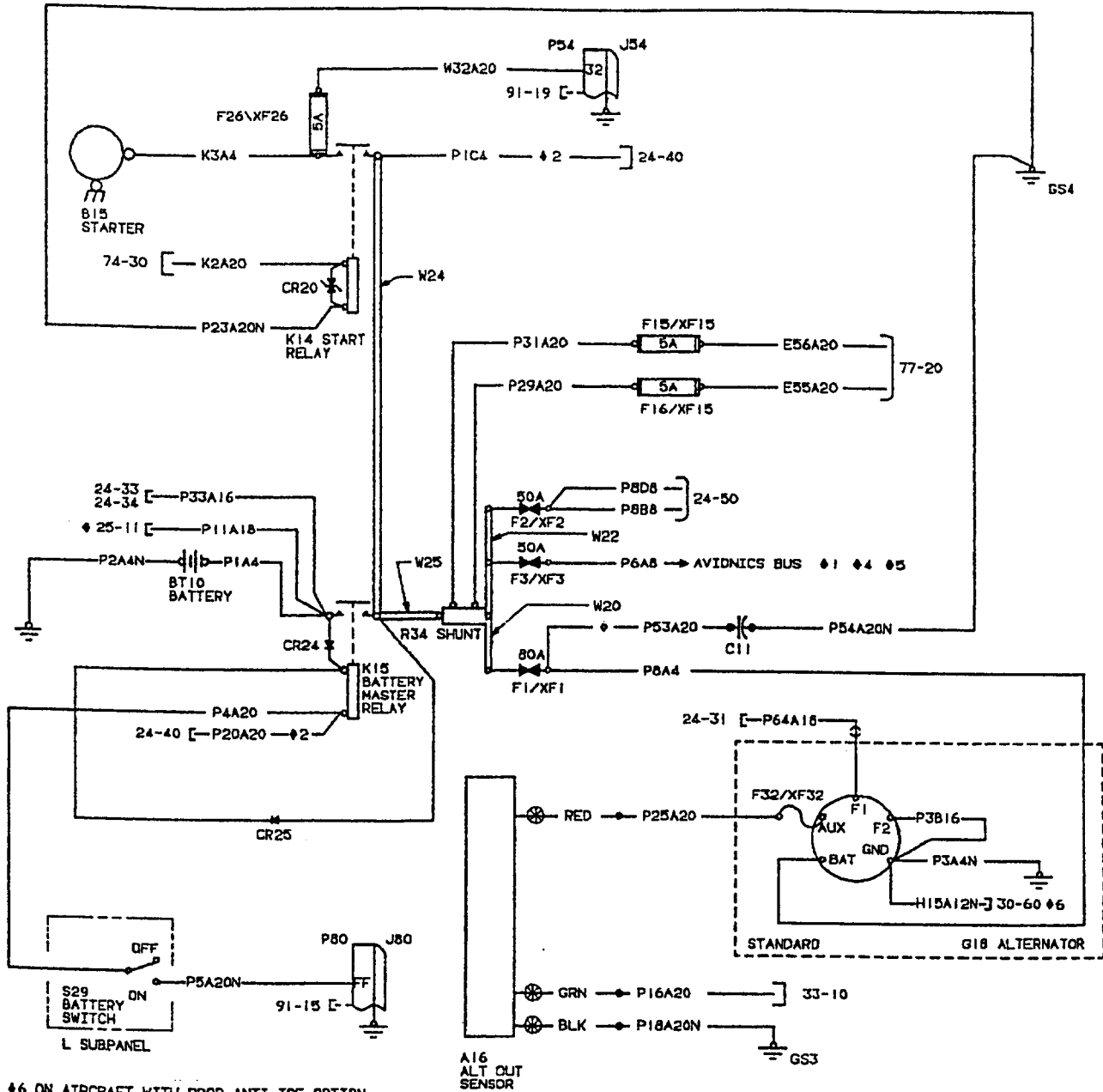

- ♦6 ON AIRCRAFT WITH PROP ANTI-ICE OPTION.
- ♦5 WHEN OPTIONAL SINGLE NAV IS USED REFER TO DIAG 24-52.
- ♦4 WHEN OPTIONAL DUAL NAV IS USED REFER TO DIAG 24-51.
- ♦2 ON ACFT WITH EXTERNAL POWER OPTION.
- ♦1 REFER TO APPLICABLE AVIONICS DIAG FOR MODE OF CONNECTION.
- ♦ ON ACFT HAVING OPTIONAL CONTROL WHEEL CLOCK INSTALLED, REF DIAGRAM 25-12 REPLACES REF DIAGRAM 25-11.
- ♦1 WIRE LENGTH MUST BE KEPT LESS THAN 3-INCHES.
- ♦ WIRE LENGTH MUST BE KEPT LESS THAN 6-INCHES.

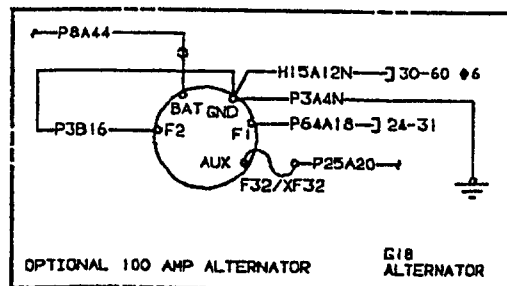

CE24F982877AA

ALTERNATOR CE-1029 THRU CE-1791; CJ-156 THRU CJ-179 (Configuration 3)

Raytheon Aircraft

BEECH BONANZA WIRING DIAGRAM MANUAL

REFERENCE DESIGNATOR	PART NUMBER	DESCRIPTION	INSTL ZONE	USABLE ON CODE
-------------------------	-------------	-------------	---------------	----------------------

24-30-04
(Configuration 3)

NOTE

REFER TO THE ALTERNATOR (G18)
INSTALLED IN THE AIRPLANE FOR THE
CORRECT PART NUMBER.

CODES OF EFFECTIVITY

1. CE-1029 THRU CE-1791; CJ-156 THRU CJ-179

Raytheon Aircraft

BEECH BONANZA WIRING DIAGRAM MANUAL

24-30-04

ALTERNATOR

(Configuration 4)

CE-1792 AND AFTER; CJ-180 AND AFTER

Raytheon Aircraft

BEECH BONANZA WIRING DIAGRAM MANUAL

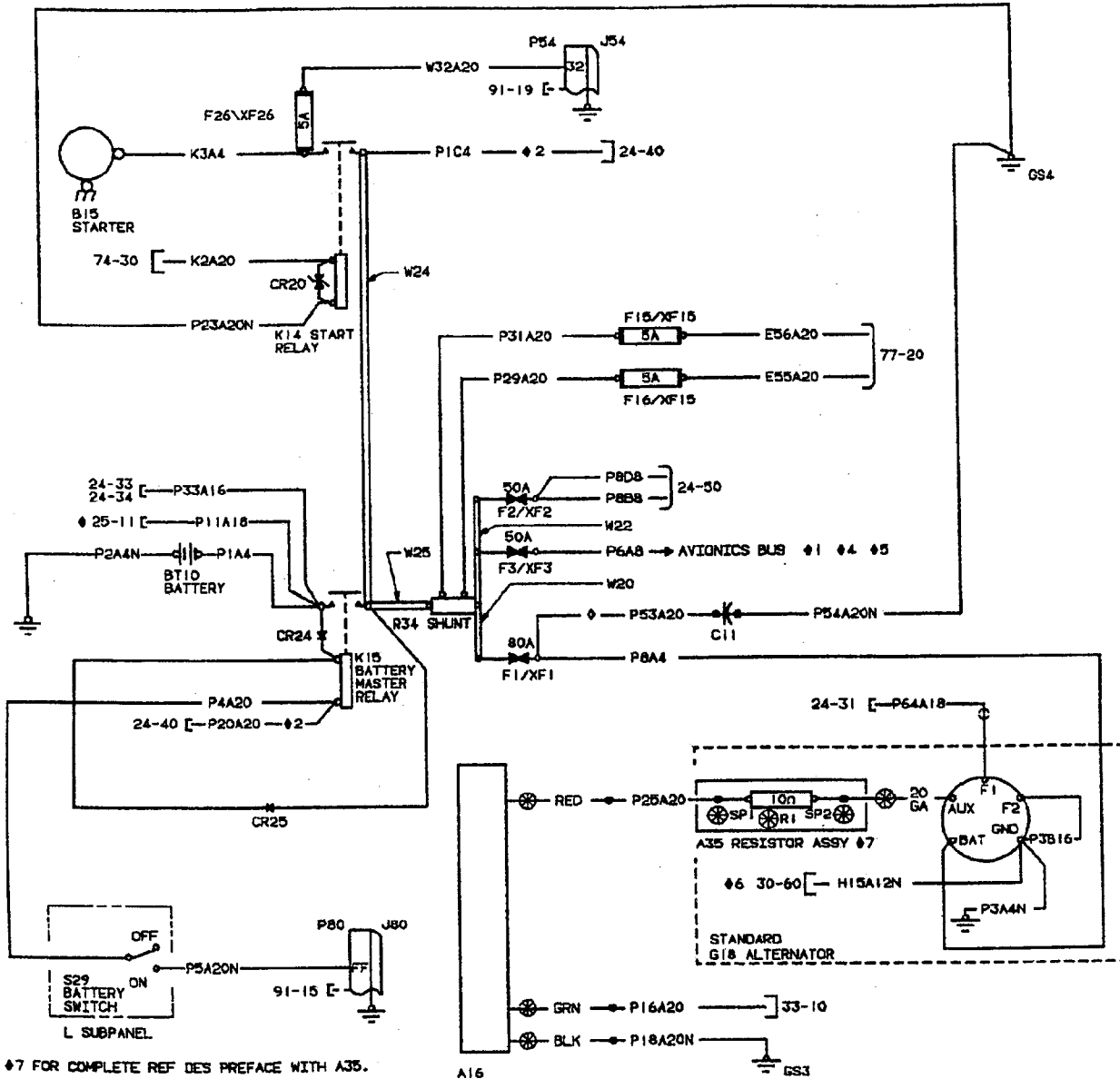

- ♦7 FOR COMPLETE REF DES PREFACE WITH A35.
- ♦6 ON AIRCRAFT WITH PROP ANTI-ICE OPTION.
- ♦5 WHEN OPTIONAL SINGLE NAV IS USED REFER TO DIAG 24-52.
- ♦4 WHEN OPTIONAL DUAL NAV IS USED REFER TO DIAG 24-51.
- ♦2 ON ACFT WITH EXTERNAL POWER OPTION.
- ♦1 REFER TO APPLICABLE AVIONICS DIAG FOR MODE OF CONNECTION.
- ♦ ON ACFT HAVING OPTIONAL CONTROL WHEEL CLOCK INSTALLED, REF DIAGRAM 25-12 REPLACES REF DIAGRAM 25-11.
- ♦1 WIRE LENGTH MUST BE KEPT LESS THAN 3-INCHES.
- ♦ WIRE LENGTH MUST BE KEPT LESS THAN 6-INCHES.

A16
ALT OUT
SENSOR

CE24F982878AA

ALTERNATOR CE-1792 AND AFTER; CJ-180 AND AFTER (Configuration 4)

Raytheon Aircraft

BEECH BONANZA WIRING DIAGRAM MANUAL

REFERENCE DESIGNATOR	PART NUMBER	DESCRIPTION	INSTL ZONE	USABLE ON CODE
24-30-04				
(Configuration 4)				
A16	36-380000-3	SENSOR-ALTERNATOR OUT	222	1
A35R1	WF2K10R	FUSIBLE RESISTOR	410	1
A35SP1	D426-36	SPLICE	410	1
A35SP2	D426-37	SPLICE	410	1
BT10	PS12-11	BATTERY (ALTN FOR 36-380059-1)	222	1
BT10	36-380059-1	BATTERY (ALTN FOR PS12-11)	222	1
B15	MHJ-4003	STARTER (ALTN FOR 637847)	222	1
B15	637847	STARTER (ALTN FOR MHJ-4003)	222	1
CR20	1.5KE51CA	TRANSZORB	222	1
CR24	1N4007	DIODE (SUPERSEDED BY 132408-22)	222	1
CR24	132408-22	DIODE (SUPERSEDES 1N4007)	222	1
CR25	1N4007	DIODE (SUPERSEDED BY 132408-22)	222	1
CR25	132408-22	DIODE (SUPERSEDES 1N4007)	222	1
C11	39D507G050GL4	CAPACITOR-ALTERNATOR (OPTL)	410	1
F1	FLLB	LIMITER-ELECTRIC, ALTERNATOR OUTPUT	222	1
F15	AGC5	FUSE-AMMETER	222	1
F16	AGC5	FUSE-AMMETER	222	1
F2	FLLA	LIMITER-ELECTRICAL BUS	222	1
F26	AGC5	FUSE-START ANNUNCIATOR (OPTL)	222	1
F3	FLLA	LIMITER-AVIONICS BUS	222	1
GS3	131270-3	GROUND STUD-FIREWALL	221	1
GS4	AN3-5A	GROUND STUD-LOWER FIREWALL	222	1
G18	646490-A1	ALTERNATOR, 60 AMP	410	1
G18	646491-A1	ALTERNATOR, 100 AMP (OPTL)	410	1
J54A	206151-2	RECEPTACLE-JUNCTION BOX ASSEMBLY	231	1
J54B	206138-1	STRAIN RELIEF	231	1
J54C	66103-2	PIN CONTACT	231	1
K14	6041H190	RELAY-START	222	1
K15	6041H189	RELAY-BATTERY MASTER	222	1
P54A	206150-1	PLUG-JUNCTION BOX ASSEMBLY	231	1
P54B	206138-1	STRAIN RELIEF	231	1
P54C	66105-2	SOCKET CONTACT	231	1
P80A	200838-3	PLUG-GROUNDING BLOCK	231	1
P80B	201224-1	STRAIN RELIEF	231	1
P80C	201328-1	SOCKET CONTACT	231	1
P80D	200333-1	SOCKET CONTACT	231	1
P80E	203618-1	JACKSCREW	231	1
R34	MS91586-6	SHUNT-100 AMP (OPTL)	222	1
R34	MLA-60-50	SHUNT-60 AMP	131	1
S29	35-380053-21	SWITCH-BATTERY	240	1
W20	36-364001-27	BUS BAR-ALTERNATOR LIMITER	222	1
W22	002-361016-7	BUS BAR-LIMITER	222	1
W24	36-364001-13	BUS BAR-STARTER RELAY	222	1
W25	36-364001-19	BUS BAR-BATTERY MASTER	222	1
XF1	FSH	LIMITER BASE-ALTERNATOR	222	1
XF15	4532	FUSEHOLDER-AMMETER/CLOCK	222	1
XF2	FSH	LIMITER BASE-ELECTRIC BUS	222	1
XF26	60-369025-2	FUSEHOLDER-START ANNUNCIATOR LIGHT	222	1
XF3	FSH	LIMITER BASE-AVIONICS BUS	222	1

Raytheon Aircraft

BEECH BONANZA WIRING DIAGRAM MANUAL

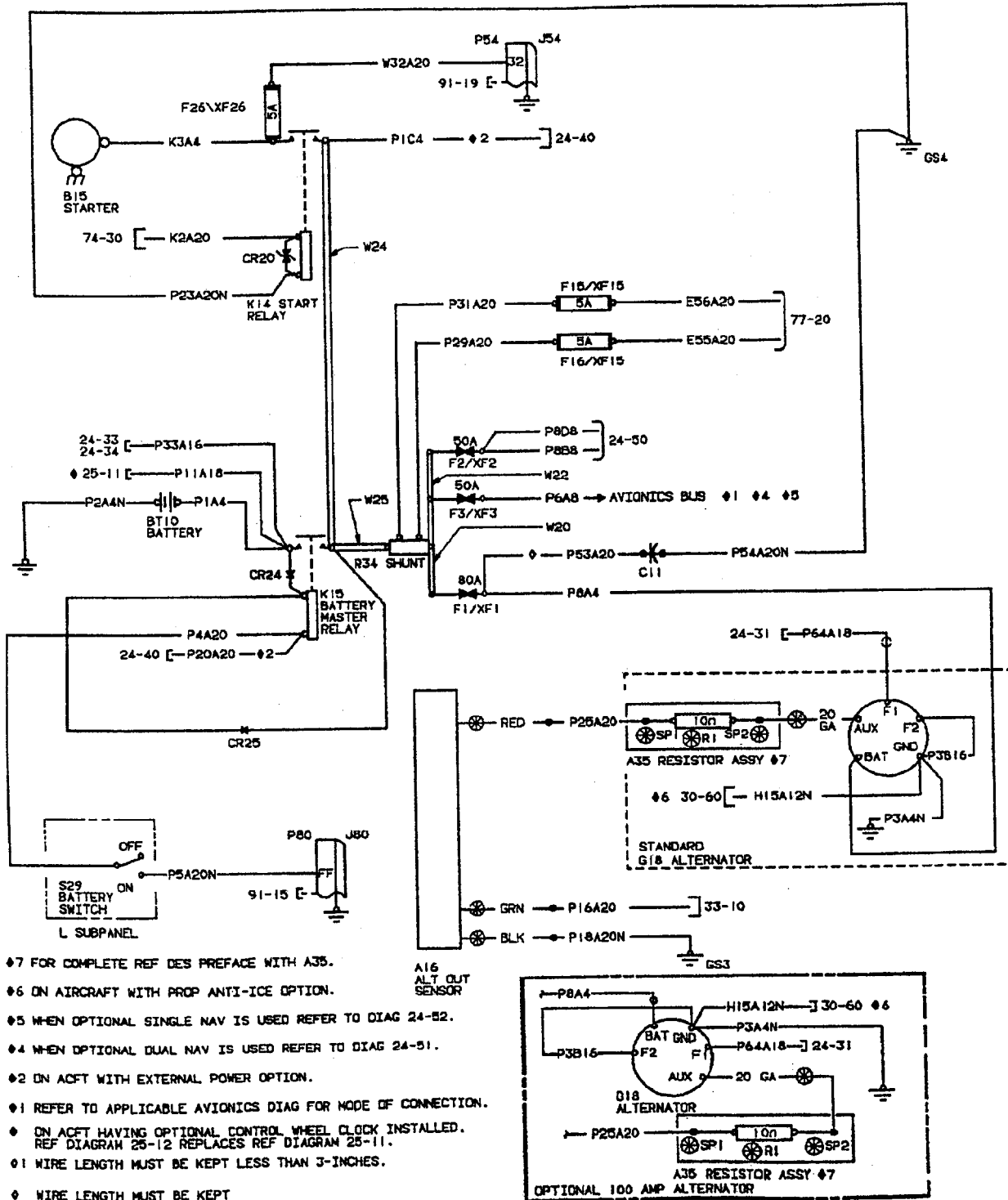

CE24F982878AA

ALTERNATOR CE-1792 AND AFTER; CJ-180 AND AFTER (Configuration 4)

Raytheon Aircraft

BEECH BONANZA WIRING DIAGRAM MANUAL

REFERENCE DESIGNATOR	PART NUMBER	DESCRIPTION	INSTL ZONE	USABLE ON CODE
-------------------------	-------------	-------------	---------------	----------------------

24-30-04
(Configuration 4)

NOTE

REFER TO THE ALTERNATOR (G18)
INSTALLED IN THE AIRPLANE FOR THE
CORRECT PART NUMBER.

CODES OF EFFECTIVITY

1. CE-1792 AND AFTER; CJ-180 AND AFTER

Beechcraft
BONANZA
WIRING DIAGRAM MANUAL

24-31-01

**E-1111, E-1241 THRU E-1945, E-1947 THRU E-2103, E-2105 THRU
E-2110; CE-748, CE-772 AND AFTER; CJ-149 THRU CJ-179; D-10097,
D-10120 AND AFTER; EA-1 THRU EA-319, EA-321 THRU EA-388**

Beechcraft BONANZA WIRING DIAGRAM MANUAL

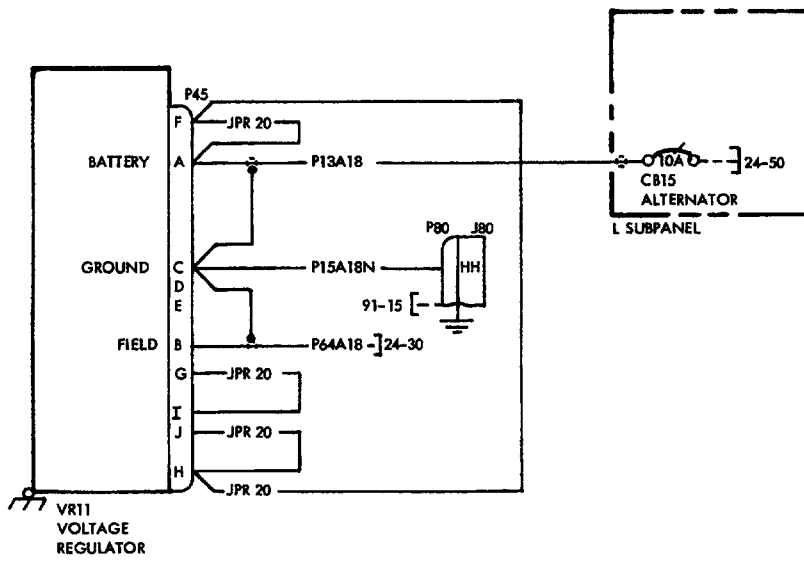

VOLTAGE REGULATOR

Deechcraft
BONANZA
WIRING DIAGRAM MANUAL

REFERENCE DESIGNATOR	PART NUMBER	DESCRIPTION	USABLE	
			INSTL ZONE	ON CODE
24-31-01				
CB15	35-380132-13	CIRCUIT BREAKER-ALTERNATOR SWITCH	240	1
J80	204814-1	RECEPTACLE-GROUNDING BLOCK	231	1
P45	MS3106A18-1S	PLUG-VOLTAGE REGULATOR	232	1
P80A	200838-3	PLUG-GROUNDING BLOCK	231	1
P80B	201224-1	STRAIN RELIEF	231	1
P80C	201328-1	SOCKET CONTACT	231	1
P80D	200333-1	SOCKET CONTACT	231	1
P80E	203618-1	JACKSCREW	231	1
VR11	36-380056-5	VOLTAGE REGULATOR (ALTN FOR 36-380096-1)	232	1
VR11	36-380096-1	VOLTAGE REGULATOR (ALTN FOR 36-380056-5)	232	1

EFFECTIVITY CODE

1. E-1111, E-1241 THRU E-1945, E-1947 THRU E-2103, E-2105 THRU E-2110; CE-748, CE-772 THRU CE-1141; CJ-149 THRU CJ-179; D-10097, D-10120 AND AFTER; EA-1 THRU EA-319, EA-321 THRU EA-388

Raytheon Aircraft

BEECH BONANZA WIRING DIAGRAM MANUAL

24-33-01

**POWER-EMERGENCY, DUAL NAVIGATION/COMMUNICATIONS
(OPTIONAL)**

**E-1424 THRU E-1786; CE-834 THRU CE-933; CJ-149 THRU CJ-155; D-10206 THRU D-10357; EA-52 THRU
EA-173**

Raytheon Aircraft

BEECH BONANZA WIRING DIAGRAM MANUAL

REFERENCE DESIGNATOR	PART NUMBER	DESCRIPTION	INSTL ZONE	USABLE ON CODE
24-33-01				
CB26	435-205-104	CIRCUIT BREAKER-START RELAY	240	3
CB26	7277-2-5	CIRCUIT BREAKER-START RELAY	240	4
CB28	7277-2-5	CIRCUIT BREAKER-OIL AND CYLINDER HEAD TEMP	240	4
CB28	435-205-104	CIRCUIT BREAKER-OIL AND CYLINDER HEAD TEMP	240	3
CB30	7277-2-5	CIRCUIT BREAKER-FUEL QUANTITY INDICATOR	240	4
CB30	435-205-104	CIRCUIT BREAKER-FUEL QUANTITY INDICATOR	240	3
CR19	1.5KE51CA	TRANSZORB-LATCH-IN RELAY (OPTL)	232	1
CR31	1N4007	DIODE-STANDBY LIGHTING (OPTL) (SUPERSEDED BY 132408-22)	222	1
CR31	132408-22	DIODE-STANDBY LIGHTING (OPTL) (SUPERSEDES 1N4007)	222	1
CR32	1.5KE51CA	TRANSZORB-STANDBY POWER RELAY (OPTL)	240	1
CR33	1N1202A	DIODE-STANDBY POWER (OPTL) (SUPERSEDED BY 132408-10)	232	1
CR33	132408-10	DIODE-STANDBY POWER (OPTL) (SUPERSEDES 1N1202A)	232	1
CR34	1N4007	DIODE (OPTL) (SUPERSEDED BY 132408-22)	232	1
CR34	132408-22	DIODE (OPTL) (SUPERSEDES 1N4007)	232	1
CR40	1N4007	DIODE-GLARESHIELD LIGHT (OPTL) (SUPERSEDED BY 132408-22)	231	1
CR40	132408-22	DIODE-GLARESHIELD LIGHT (OPTL) (SUPERSEDES 1N4007)	231	1
CR41	1.5KE51CA	TRANSZORB-STANDBY BATTERY RELAY (OPTL)	222	1
CR42	1N4007	DIODE-STANDBY POWER SWITCH (OPTL) (SUPER- SEDED BY 132408-22)	232	1
CR42	132408-22	DIODE-STANDBY POWER SWITCH (OPTL) (SUPER- SEDES 1N4007)	232	1
CR43	1N4007	DIODE-STANDBY POWER SWITCH (OPTL) (SUPER- SEDED BY 132408-22)	232	1
CR43	132408-22	DIODE-STANDBY POWER SWITCH (OPTL) (SUPER- SEDES 1N4007)	232	1
C10	39D507G050GL4	CAPACITOR-STANDBY GENERATOR (OPTL)	222	1
DS30	313	LAMP-GLARESHIELD	240	1
DS91A	58-380022-11	LIGHT TRAY-STANDBY GENERATOR (OPTL)	240	1
DS91B	267	LAMP (OPTL)	240	1
F11	AGC-15	FUSE-STANDBY BUS	222	1
GS2	131270-3	GROUND STUD-FIREWALL	221	1
G17	36-380048-1	GENERATOR-STANDBY (OPTL)	410	1
J31A	1-480340-0	RECEPTACLE-GLARESHIELD	231	1
J31B	1-480345-0	PIN HOUSING	231	1
J31C	60618-1	PIN CONTACT	231	1
K10	50-380048-1	RELAY-STANDBY BATTERY POWER (OPTL)	222	1
K11	50-380048-1	RELAY-STANDBY POWER (OPTL)	240	1
K13	50-380048-1	RELAY-GENERATOR LATCH-IN (OPTL)	232	1
M15	60-384038	VOLTMETER-STANDBY GENERATOR OPTL)	240	1
P31A	1-480270-0	PLUG-GLARESHIELD	231	1
P31B	1-480283-0	SOCKET HOUSING	231	1
P31C	60617-1	SOCKET CONTACT	231	1
P46	MS3106A18-1S	PLUG-STANDBY VOLTAGE REGULATOR (OPTL)	232	1
P80A	200838-3	PLUG-GROUNDING BLOCK	231	1
P80B	201224-1	STRAIN RELIEF	231	1
P80C	201328-1	SOCKET CONTACT	231	1

Raytheon Aircraft

BEECH BONANZA WIRING DIAGRAM MANUAL

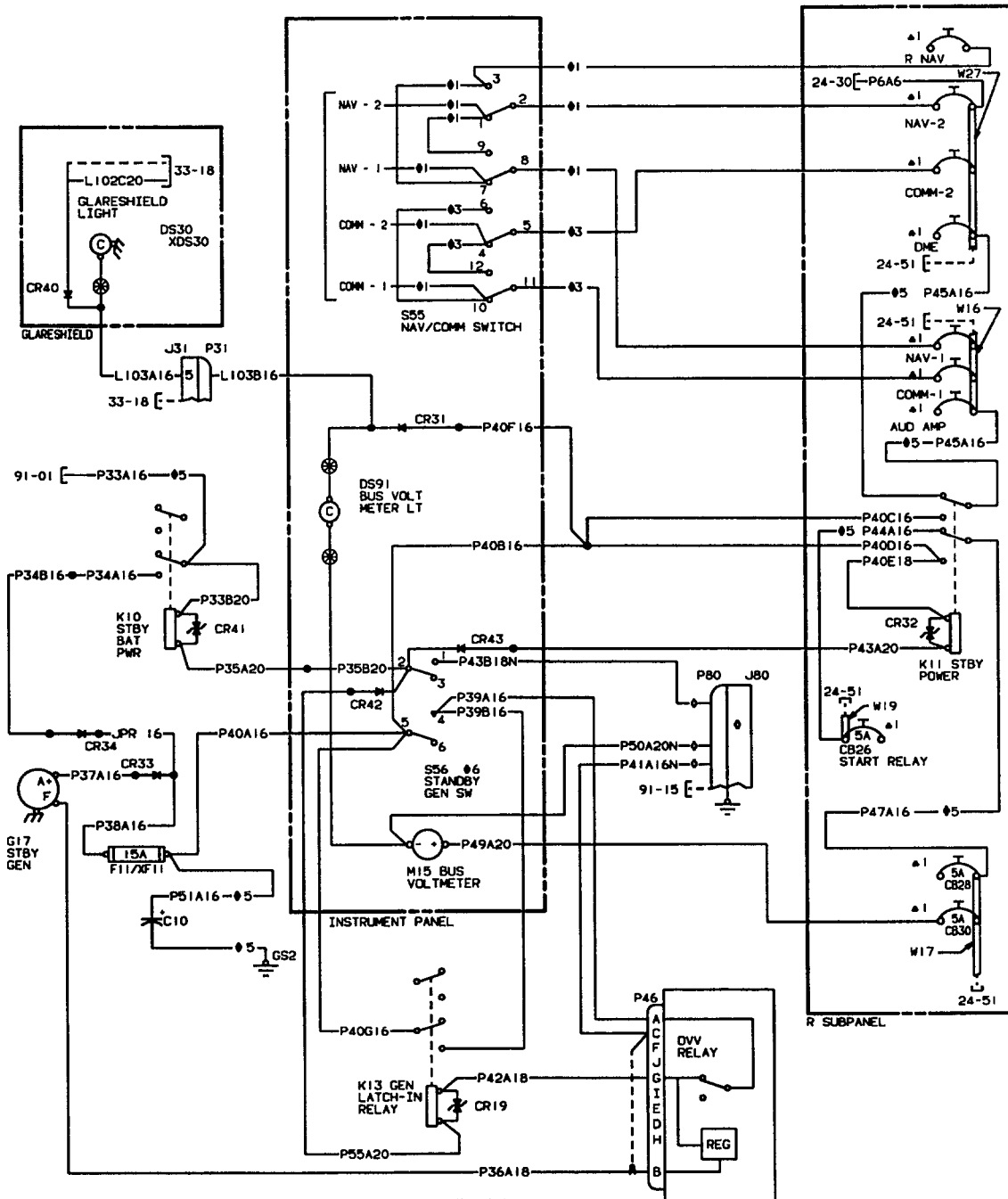

- ◆ REFER TO APPLICABLE AVIONICS DWF MODE OF CONNECTION
- ◆1 AWG 20 WIRE
- ◆2 AWG 18 WIRE
- ◆3 WIRE LENGTH TO BE KEPT TO A MINIMUM

- ◆6 S56 SWITCHING
RESET 1-2 4-5 (MON)
ON 1-2 5-6
OFF 2-3 5-6

- ◆ ON ACFT PRIOR TO E-1787 & AFT EA-174 & AFT CE-934 & AFT CJ-156 & AFT D-10358 & AFT, THESE WIRES MAY TERMINATE AT ANY OPEN PIN OF GND CONNECTOR P/J80

CE24F
982525AA

**POWER-EMERGENCY, DUAL NAVIGATION/COMMUNICATIONS (OPTIONAL)
E-1424 THRU E-1786; CE-834 THRU CE-933; CJ-149 THRU CJ-155; D-10206 THRU
D-10357; EA-52 THRU EA-173**

Raytheon Aircraft

BEECH BONANZA WIRING DIAGRAM MANUAL

REFERENCE DESIGNATOR	PART NUMBER	DESCRIPTION	INSTL ZONE	USABLE ON CODE
24-33-01				
P80D	200333-1	SOCKET CONTACT	231	1
P80E	203618-1	JACKSCREW	231	1
S55	35-380053-9	SWITCH-NAV/COMM GENERATOR (OPTL)	240	1
S56	35-380053-11	SWITCH-STANDBY GENERATOR POWER (OPTL)	240	1
VR12	36-380056-1	VOLTAGE REGULATOR-STANDBY GENERATOR	232	2
W16	114931-1-4	BUS BAR (OPTL)	240	1
W17	114931-1-3	BUS BAR (OPTL)	240	1
W19	114931-1-10	BUS BAR (OPTL)	240	1
W27	114931-1-4	BUS BAR (OPTL)	240	1
XDS30	4169-143	LAMPHOLDER	240	1
XF11	4522	FUSE BLOCK (OPTL)	222	1

CODES OF EFFECTIVITY

1. E-1424 THRU E-1786; CE-834 THRU CE-933; CJ-149 THRU CJ-155; D-10206 THRU D-10357; EA-52 THRU EA-173
2. CE-834 THRU CE-933
3. E-1424 THRU E-1765; CE-834 THRU CE-918, CE-920 THRU CE-928; CJ-149 THRU CJ-155; D-10206 THRU D-10347, D-10349 THRU D-10353; EA-52 THRU EA-158
4. E-1766 THRU E-1786; CE-919, CE-929 THRU CE-933; D-10348, D-10354 THRU D-10357; EA-159 THRU EA-173

Raytheon Aircraft

BEECH BONANZA WIRING DIAGRAM MANUAL

24-33-02

**POWER-EMERGENCY, DUAL NAVIGATION/COMMUNICATIONS
(OPTIONAL)**

**E-1787 THRU E-1945, E-1947 THRU E-2103, E-2105 THRU E-2110; CE-934 AND AFTER; CJ-156 AND
AFTER; D-10358 AND AFTER; EA-174 THRU EA-319, EA-321 THRU EA-388**

Raytheon Aircraft

BEECH BONANZA WIRING DIAGRAM MANUAL

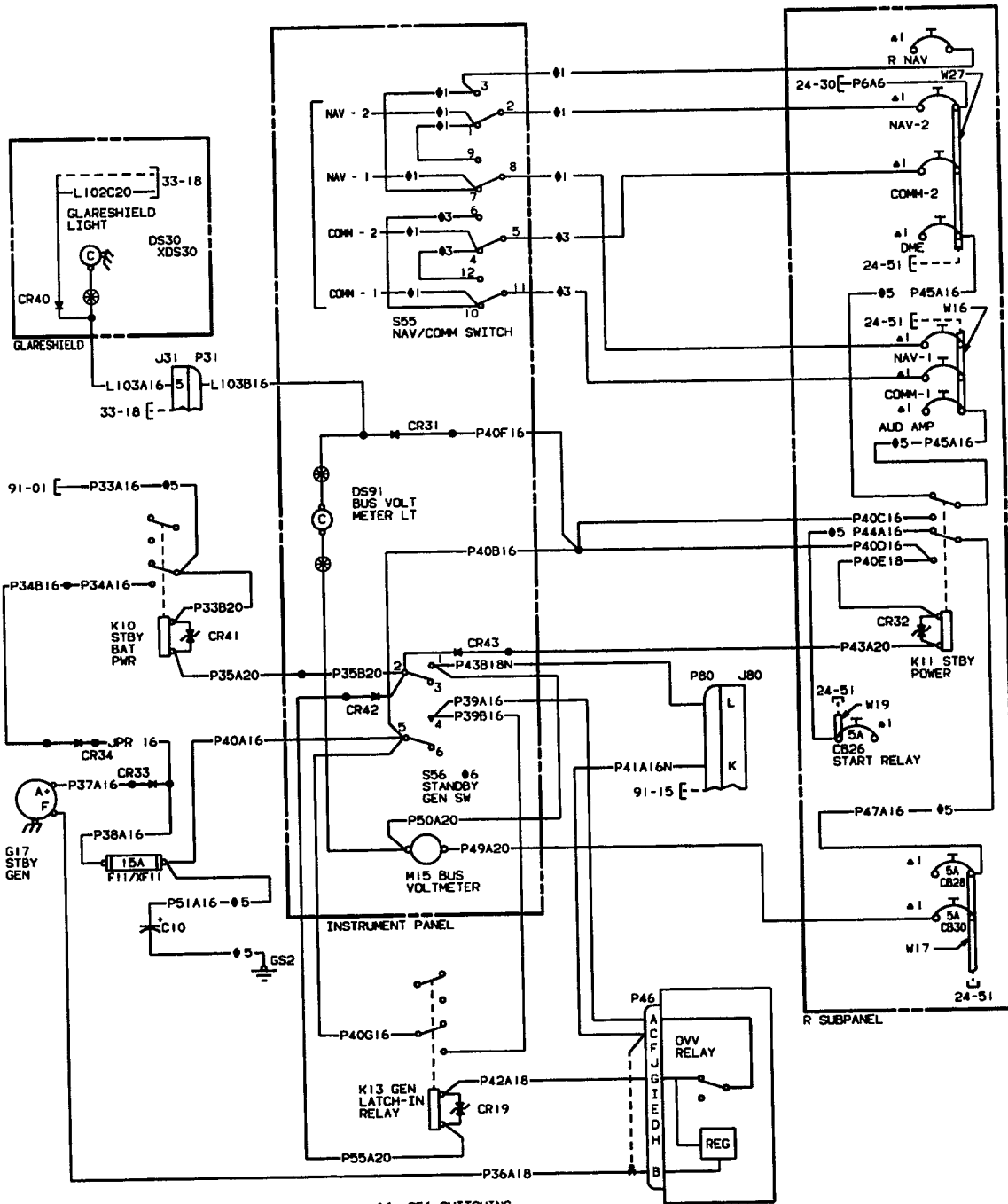

- ◆ REFER TO APPLICABLE AVIONICS DWF MODE OF CONNECTION
- 1 AWG 20 WIRE
- 3 AWG 18 WIRE
- 5 WIRE LENGTH TO BE KEPT TO A MINIMUM

- 6 S56 SWITCHING
 RESET 1-2 4-5 (MOM)
 ON 1-2 5-6
 OFF 2-3 5-6

VR12 STANDBY GEN VOLT REG

CE24F
982526AA

**POWER-EMERGENCY, DUAL NAVIGATION/COMMUNICATIONS (OPTIONAL)
 E-1787 THRU E-1945, E-1947 THRU E-2103, E-2105 THRU E-2110; CE-934 AND
 AFTER; CJ-156 AND AFTER; D-10358 AND AFTER; EA-174 THRU EA-319, EA-321
 THRU EA-388**

Raytheon Aircraft

BEECH BONANZA WIRING DIAGRAM MANUAL

REFERENCE DESIGNATOR	PART NUMBER	DESCRIPTION	INSTL ZONE	USABLE ON CODE
24-33-02				
CB26	7277-2-5	CIRCUIT BREAKER-START RELAY	240	1
CB28	7277-2-5	CIRCUIT BREAKER-OIL AND CYLINDER HEAD TEMP	240	1
CB30	7277-2-5	CIRCUIT BREAKER-FUEL QUANTITY INDICATOR	240	1
CR19	1.5KE51CA	TRANSZORB-LATCH-IN RELAY (OPTL)	232	1
CR31	1N4007	DIODE-STANDBY LIGHTING (OPTL) (SUPERSEDED BY 132408-22)	222	1
CR31	132408-22	DIODE-STANDBY LIGHTING (OPTL) (SUPERSEDES 1N4007)	222	1
CR32	1.5KE51CA	TRANSZORB-STANDBY POWER RELAY (OPTL)	240	1
CR33	1N1202A	DIODE-STANDBY POWER (OPTL) (SUPERSEDED BY 132408-10)	232	1
CR33	132408-10	DIODE-STANDBY POWER (OPTL) (SUPERSEDES 1N1202A)	232	1
CR34	1N4007	DIODE-STANDBY POWER (OPTL) (SUPERSEDED BY 132408-22)	232	1
CR34	132408-22	DIODE-STANDBY POWER (OPTL) (SUPERSEDES 1N4007)	232	1
CR40	1N4007	DIODE-GLARESHIELD LIGHT (OPTL) (SUPERSEDED BY 132408-22)	231	1
CR40	132408-22	DIODE-GLARESHIELD LIGHT (OPTL) (SUPERSEDES 1N4007)	231	1
CR41	1.5KE51CA	TRANSZORB-STANDBY BATTERY RELAY (OPTL)	222	1
CR42	1N4007	DIODE-STANDBY POWER SWITCH (OPTL) (SUPERSEDED BY 132408-22)	232	1
CR42	132408-22	DIODE-STANDBY POWER SWITCH (OPTL) (SUPERSEDES 1N4007)	232	1
CR43	1N4007	DIODE-STANDBY POWER SWITCH (OPTL) (SUPERSEDED BY 132408-22)	232	1
CR43	132408-22	DIODE-STANDBY POWER SWITCH (OPTL) (SUPERSEDES 1N4007)	232	1
C10	39D507G050GL4	CAPACITOR-STANDBY GENERATOR (OPTL)	222	1
DS30	313	LAMP-GLARESHIELD	240	1
DS91A	58-380022-11	LIGHT TRAY-STANDBY GENERATOR (OPTL)	240	1
DS91B	267	LAMP (OPTL)	240	1
F11	AGC-15	FUSE-STANDBY BUS	222	1
GS2	131270-3	GROUND STUD-FIREWALL	221	1
G17	36-380048-1	GENERATOR-STANDBY (OPTL)	410	1
J31A	1-480340-0	RECEPTACLE-GLARESHIELD	231	1
J31B	1-480345-0	PIN HOUSING	231	1
J31C	60618-1	PIN CONTACT	231	1
K10	50-380048-1	RELAY-STANDBY BATTERY POWER (OPTL)	222	1
K11	50-380048-1	RELAY-STANDBY POWER (OPTL)	240	1
K13	50-380048-1	RELAY-GENERATOR LATCH-IN (OPTL)	232	1
M15	60-384038	VOLTMETER-STANDBY GENERATOR OPTL)	240	1
P31A	1-480270-0	PLUG-GLARESHIELD	231	1
P31B	1-480283-0	SOCKET HOUSING	231	1
P31C	60617-1	SOCKET CONTACT	231	1
P46	MS3106A18-1S	PLUG-STANDBY VOLTAGE REGULATOR (OPTL)	232	1
P80A	200838-3	PLUG-GROUNDING BLOCK	231	1
P80B	201224-1	STRAIN RELIEF	231	1
P80C	201328-1	SOCKET CONTACT	231	1
P80D	200333-1	SOCKET CONTACT	231	1

Raytheon Aircraft

BEECH BONANZA WIRING DIAGRAM MANUAL

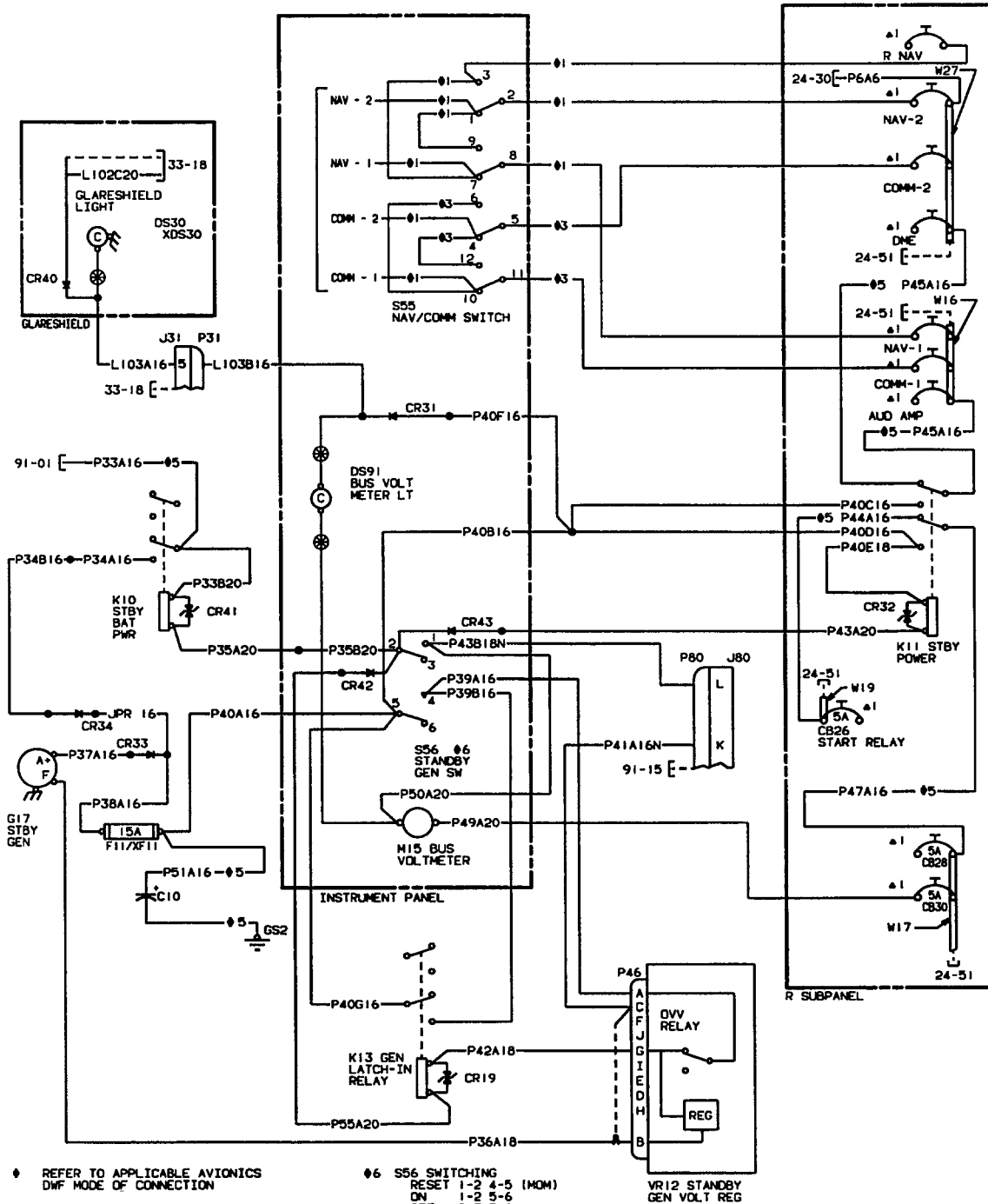

CE24F
982526AA

**POWER-EMERGENCY, DUAL NAVIGATION/COMMUNICATIONS (OPTIONAL)
 E-1787 THRU E-1945, E-1947 THRU E-2103, E-2105 THRU E-2110; CE-934 AND
 AFTER; CJ-156 AND AFTER; D-10358 AND AFTER; EA-174 THRU EA-319, EA-321
 THRU EA-388**

Raytheon Aircraft

BEECH BONANZA WIRING DIAGRAM MANUAL

REFERENCE DESIGNATOR	PART NUMBER	DESCRIPTION	INSTL ZONE	USABLE ON CODE
24-33-02				
P80E	203618-1	JACKSCREW	231	1
S55	35-380053-9	SWITCH-NAV/COMM GENERATOR (OPTL)	240	1
S56	35-380053-11	SWITCH-STANDBY GENERATOR POWER (OPTL)	240	1
VR12	36-380056-1	VOLTAGE REGULATOR-STANDBY GENERATOR	232	2
VR12	36-380056-3	VOLTAGE REGULATOR-STANDBY GENERATOR	232	3
W16	114931-1-4	BUS BAR (OPTL)	240	1
W17	114931-1-3	BUS BAR (OPTL)	240	1
W19	114931-1-10	BUS BAR (OPTL)	240	1
W27	114931-1-4	BUS BAR (OPTL)	240	1
XDS30	4169-143	LAMPHOLDER	240	1
XF11	4522	FUSE BLOCK (OPTL)	222	1

CODES OF EFFECTIVITY

1. E-1787 THRU E-1945, E-1947 THRU E-2103, E-2105 THRU E-2110; CE-934 AND AFTER; CJ-156 AND AFTER; D-10358 AND AFTER; EA-174 THRU EA-319, EA-321 THRU EA-388
2. CE-934 THRU CE-993
3. CE-994 AND AFTER

Raytheon Aircraft

BEECH BONANZA WIRING DIAGRAM MANUAL

24-34-01

POWER-EMERGENCY, SINGLE NAVIGATION/COMMUNICATIONS

(OPTIONAL)

**E-1424 THRU E-1786; CE-834 THRU CE-933; CJ-149 THRU CJ-155; D-10206 THRU D-10357; EA-52 THRU
EA-173**

Raytheon Aircraft

BEECH BONANZA WIRING DIAGRAM MANUAL

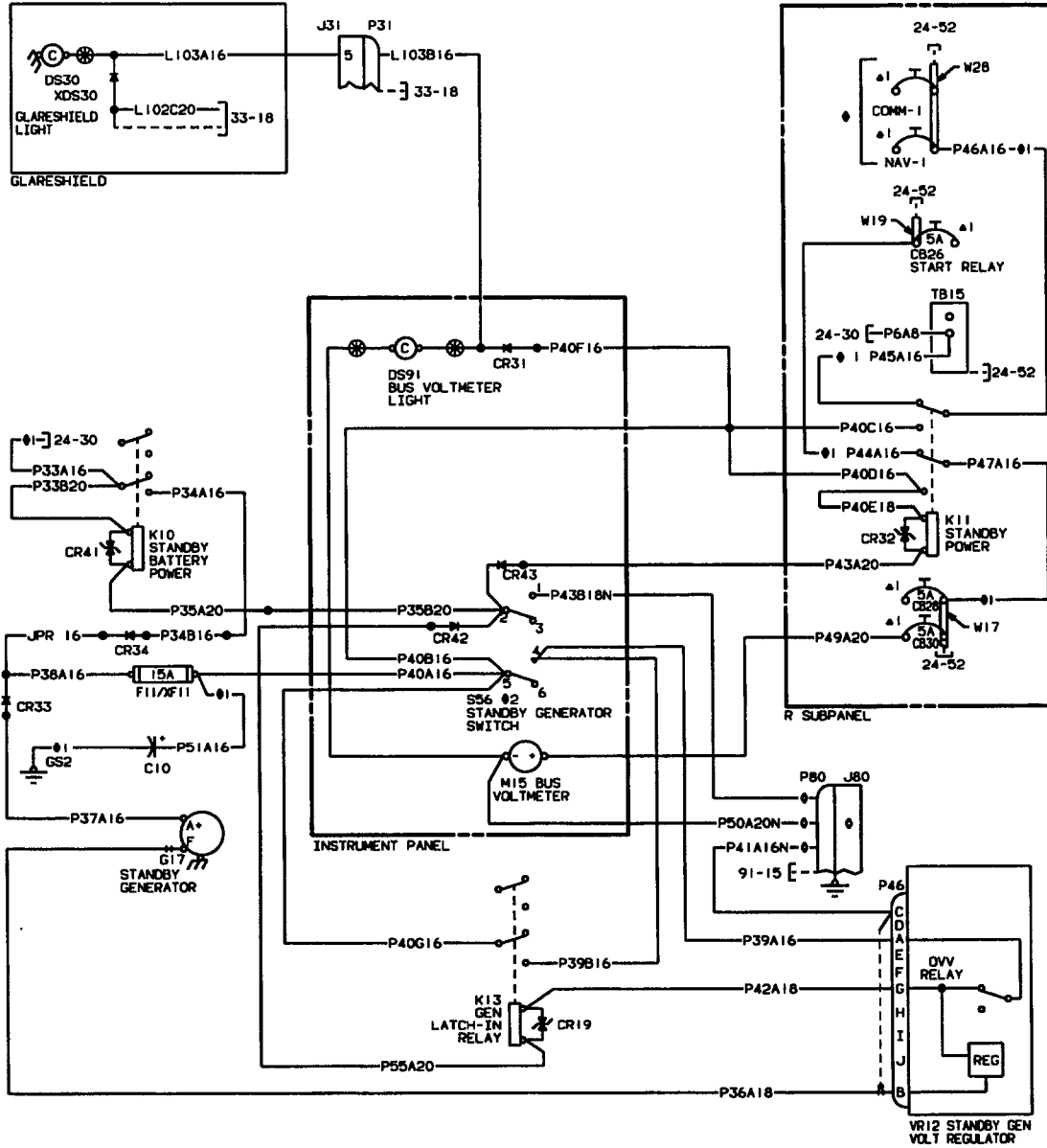

- ⊙ THESE WIRES MAY TERMINATE IN ANY OPEN PIN OF GND CONNECTOR P/J80
- ⊙ 2 S56 SWITCHING
 RESET 1-2 4-5 (NOM)
 ON 1-2 5-6
 OFF 2-3 5-6
- ⊙ REFER TO APPLICABLE AVIONICS DWG FOR MODE OF CONNECTION
- ⊙ 1 WIRE LENGTH TO BE KEPT TO A MIN

CE24F
982527AA

POWER-EMERGENCY, SINGLE NAVIGATION/COMMUNICATIONS (OPTIONAL)
 E-1424 THRU E-1786; CE-834 THRU CE-933; CJ-149 THRU CJ-155; D-10206 THRU
 D-10357; EA-52 THRU EA-173

Raytheon Aircraft

BEECH BONANZA WIRING DIAGRAM MANUAL

REFERENCE DESIGNATOR	PART NUMBER	DESCRIPTION	INSTL ZONE	USABLE ON CODE
24-34-01				
CB26	435-205-104	CIRCUIT BREAKER-START RELAY	240	3
CB26	7277-2-5	CIRCUIT BREAKER-START RELAY	240	4
CB28	7277-2-5	CIRCUIT BREAKER-OIL AND CYLINDER HEAD TEMP	240	4
CB28	435-205-104	CIRCUIT BREAKER-OIL AND CYLINDER HEAD TEMP	240	3
CB30	7277-2-5	CIRCUIT BREAKER-FUEL QUANTITY INDICATOR	240	4
CB30	435-205-104	CIRCUIT BREAKER-FUEL QUANTITY INDICATOR	240	3
CR19	1.5KE51CA	TRANSZORB-LATCH-IN RELAY (OPTL)	232	1
CR31	1N4007	DIODE-STANDBY LIGHTING (OPTL) (SUPERSEDED BY 132408-22)	222	1
CR31	132408-22	DIODE-STANDBY LIGHTING (OPTL) (SUPERSEDES 1N4007)	222	1
CR32	1.5KE51CA	TRANSZORB-STANDBY POWER RELAY (OPTL)	240	1
CR33	1N1202A	DIODE-STANDBY POWER (OPTL) (SUPERSEDED BY 132408-10)	232	1
CR33	132408-10	DIODE-STANDBY POWER (OPTL) (SUPERSEDES 1N1202A)	232	1
CR34	1N4007	DIODE (OPTL) (SUPERSEDED BY 132408-22)	232	1
CR34	132408-22	DIODE (OPTL) (SUPERSEDES 1N4007)	232	1
CR40	1N4007	DIODE-GLARESHIELD LIGHT (OPTL) (SUPERSEDED BY 132408-22)	231	1
CR40	132408-22	DIODE-GLARESHIELD LIGHT (OPTL) (SUPERSEDES 1N4007)	231	1
CR41	1.5KE51CA	TRANSZORB-STANDBY BATTERY RELAY (OPTL)	222	1
CR42	1N4007	DIODE-STANDBY POWER SWITCH (OPTL) (SUPERSEDED BY 132408-22)	232	1
CR42	132408-22	DIODE-STANDBY POWER SWITCH (OPTL) (SUPERSEDES 1N4007)	232	1
CR43	1N4007	DIODE-STANDBY POWER SWITCH (OPTL) (SUPERSEDED BY 132408-22)	232	1
CR43	132408-22	DIODE-STANDBY POWER SWITCH (OPTL) (SUPERSEDES 1N4007)	232	1
C10	39D507G050GL4	CAPACITOR-STANDBY GENERATOR (OPTL)	222	1
DS30	313	LAMP-GLARESHIELD	240	1
DS91A	58-380022-11	LIGHT TRAY-STANDBY GENERATOR (OPTL)	240	1
DS91B	267	LAMP (OPTL)	240	1
F11	AGC-15	FUSE-STANDBY BUS	222	1
GS2	131270-3	GROUND STUD-FIREWALL	221	1
G17	36-380048-1	GENERATOR-STANDBY (OPTL)	410	1
J31A	1-480340-0	RECEPTACLE-GLARESHIELD	231	1
J31B	1-480345-0	PIN HOUSING	231	1
J31C	60618-1	PIN CONTACT	231	1
K10	50-380048-1	RELAY-STANDBY BATTERY POWER (OPTL)	222	1
K11	50-380048-1	RELAY-STANDBY POWER (OPTL)	240	1
K13	50-380048-1	RELAY-GENERATOR LATCH-IN (OPTL)	232	1
M15	60-384038	VOLTMETER-STANDBY GENERATOR OPTL)	240	1
P31A	1-480270-0	PLUG-GLARESHIELD	231	1
P31B	1-480283-0	SOCKET HOUSING	231	1
P31C	60617-1	SOCKET CONTACT	231	1
P46	MS3106A18-1S	PLUG-STANDBY VOLTAGE REGULATOR (OPTL)	232	1
P80A	200838-3	PLUG-GROUNDING BLOCK	231	1
P80B	201224-1	STRAIN RELIEF	231	1
P80C	201328-1	SOCKET CONTACT	231	1

Raytheon Aircraft

BEECH BONANZA WIRING DIAGRAM MANUAL

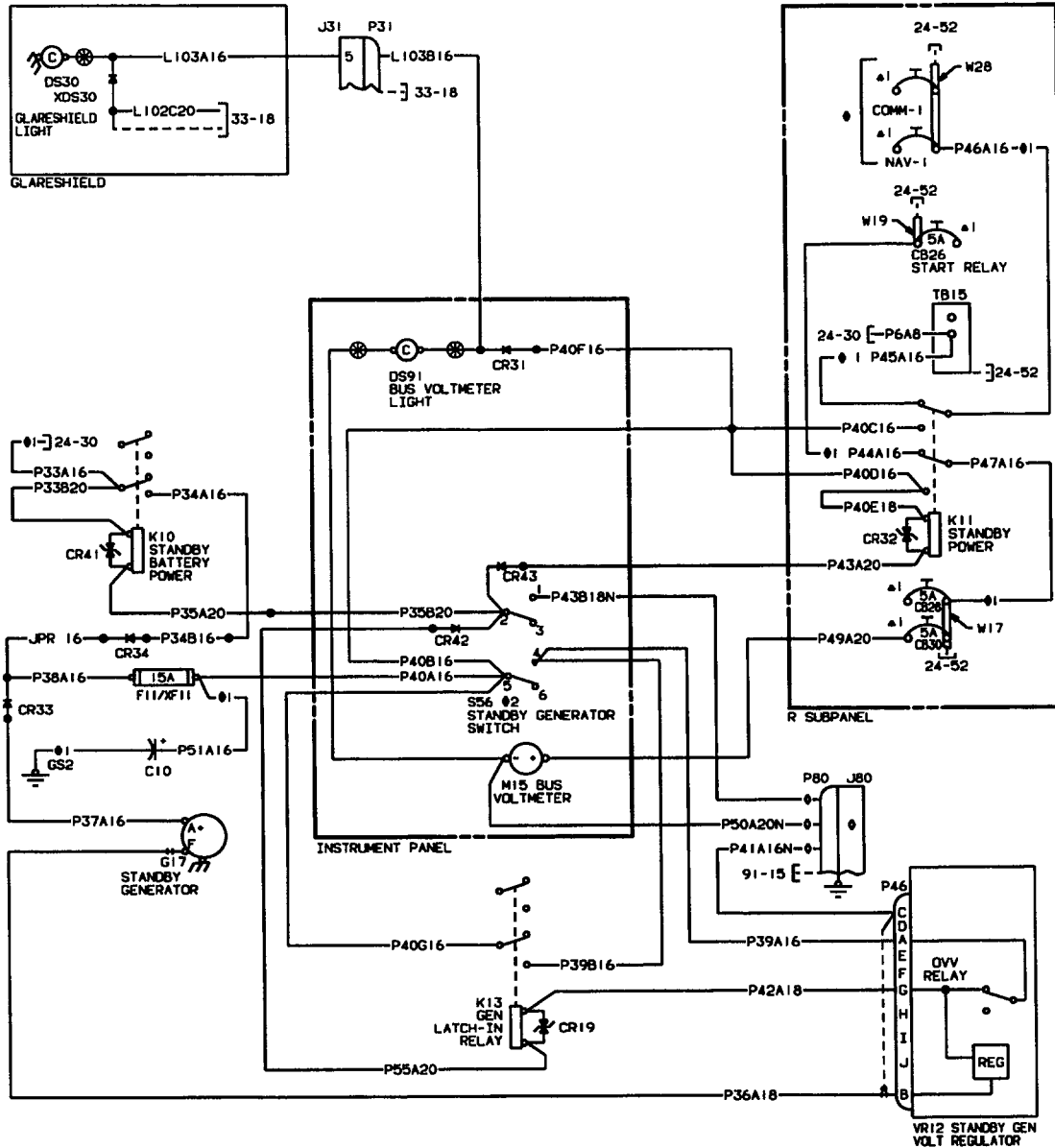

- ① THESE WIRES MAY TERMINATE IN ANY OPEN PIN OF GND CONNECTOR P/J80
- ② S56 SWITCHING
RESET 1-2 4-5 (NOM)
ON 1-2 5-6
OFF 2-3 5-6

③ REFER TO APPLICABLE AVIONICS DWG FOR MODE OF CONNECTION

④ WIRE LENGTH TO BE KEPT TO A MIN

CE24F
982527AA

POWER-EMERGENCY, SINGLE NAVIGATION/COMMUNICATIONS (OPTIONAL)
E-1424 THRU E-1786; CE-834 THRU CE-933; CJ-149 THRU CJ-155; D-10206 THRU
D-10357; EA-52 THRU EA-173

Raytheon Aircraft

BEECH BONANZA WIRING DIAGRAM MANUAL

REFERENCE			INSTL	USABLE
DESIGNATOR	PART NUMBER	DESCRIPTION	ZONE	ON
				CODE
24-34-01				
P80D	200333-1	SOCKET CONTACT	231	1
P80E	203618-1	JACKSCREW	231	1
S56	35-380053-11	SWITCH-STANDBY GENERATOR POWER (OPTL)	240	1
TB15	MS27212-2-2	TERMINAL BOARD (OPTL)	240	1
VR12	36-380056-1	VOLTAGE REGULATOR-STANDBY GENERATOR	232	2
W16	114931-1-4	BUS BAR (OPTL)	240	1
W17	114931-1-3	BUS BAR (OPTL)	240	1
W19	114931-1-10	BUS BAR (OPTL)	240	1
W28	114931-1-2	BUS BAR (OPTL)	240	1
XDS30	4169-143	LAMPHOLDER	240	1
XF11	4522	FUSE BLOCK (OPTL)	222	1

CODES OF EFFECTIVITY

1. E-1424 THRU E-1786; CE-834 THRU CE-933; CJ-149 THRU CJ-155; D-10206 THRU D-10357; EA-52 THRU EA-173
2. CE-834 THRU CE-933
3. E-1424 THRU E-1765; CE-834 THRU CE-918, CE-920 THRU CE-928; CJ-149 THRU CJ-155; D-10206 THRU D-10347, D-10349 THRU D-10353; EA-52 THRU EA-158
4. E-1766 THRU E-1786; CE-919, CE-929 THRU CE-933; D-10348, D-10354 THRU D-10357; EA-159 THRU EA-173

Raytheon Aircraft

BEECH BONANZA WIRING DIAGRAM MANUAL

24-34-02

POWER-EMERGENCY, SINGLE NAVIGATION/COMMUNICATIONS

(OPTIONAL)

E-1787 THRU E-1945, E-1947 THRU E-2103, E-2105 THRU E-2110; CE-934 AND AFTER; CJ-156 AND AFTER; D-10358 AND AFTER; EA-174 THRU EA-319, EA-321 THRU EA-388

Raytheon Aircraft

BEECH BONANZA WIRING DIAGRAM MANUAL

REFERENCE DESIGNATOR	PART NUMBER	DESCRIPTION	INSTL ZONE	USABLE ON CODE
24-34-02				
CB26	7277-2-5	CIRCUIT BREAKER-START RELAY	240	1
CB28	7277-2-5	CIRCUIT BREAKER-OIL AND CYLINDER HEAD TEMP	240	1
CB30	7277-2-5	CIRCUIT BREAKER-FUEL QUANTITY INDICATOR	240	1
CR19	1.5KE51CA	TRANSZORB-LATCH-IN RELAY (OPTL)	232	1
CR31	1N4007	DIODE-STANDBY LIGHTING (OPTL) (SUPERSEDED BY 132408-22)	222	1
CR31	132408-22	DIODE-STANDBY LIGHTING (OPTL) (SUPERSEDES 1N4007)	222	1
CR32	1.5KE51CA	TRANSZORB-STANDBY POWER RELAY (OPTL)	240	1
CR33	1N1202A	DIODE-STANDBY POWER (OPTL) (SUPERSEDED BY 132408-10)	232	1
CR33	132408-10	DIODE-STANDBY POWER (OPTL) (SUPERSEDES 1N1202A)	232	1
CR34	1N4007	DIODE (OPTL) (SUPERSEDED BY 132408-22)	232	1
CR34	132408-22	DIODE (OPTL) (SUPERSEDES 1N4007)	232	1
CR40	1N4007	DIODE-GLARESHIELD LIGHT (OPTL) (SUPERSEDED BY 132408-22)	231	1
CR40	132408-22	DIODE-GLARESHIELD LIGHT (OPTL) (SUPERSEDES 1N4007)	231	1
CR41	1.5KE51CA	TRANSZORB-STANDBY BATTERY RELAY (OPTL)	222	1
CR42	1N4007	DIODE-STANDBY POWER SWITCH (OPTL) (SUPERSEDED BY 132408-22)	232	1
CR42	132408-22	DIODE-STANDBY POWER SWITCH (OPTL) (SUPERSEDES 1N4007)	232	1
CR43	1N4007	DIODE-STANDBY POWER SWITCH (OPTL) (SUPERSEDED BY 132408-22)	232	1
CR43	132408-22	DIODE-STANDBY POWER SWITCH (OPTL) (SUPERSEDES 1N4007)	232	1
CR44	1N4007	DIODE-STANDBY POWER SWITCH (OPTL) (SUPERSEDED BY 132408-22)	232	2
CR44	132408-22	DIODE-STANDBY POWER SWITCH (OPTL) (SUPERSEDES 1N4007)	232	2
C10	39D507G050GL4	CAPACITOR-STANDBY GENERATOR (OPTL)	222	1
DS30	313	LAMP-GLARESHIELD	240	1
DS91A	58-380022-11	LIGHT TRAY-STANDBY GENERATOR (OPTL)	240	1
DS91B	267	LAMP (OPTL)	240	1
F11	AGC-15	FUSE-STANDBY BUS	222	1
GS2	131270-3	GROUND STUD-FIREWALL	221	1
G17	36-380048-1	GENERATOR-STANDBY (OPTL)	410	1
J31A	1-480340-0	RECEPTACLE-GLARESHIELD	231	1
J31B	1-480345-0	PIN HOUSING	231	1
J31C	60618-1	PIN CONTACT	231	1
K10	50-380048-1	RELAY-STANDBY BATTERY POWER (OPTL)	222	1
K11	50-380048-1	RELAY-STANDBY POWER (OPTL)	240	1
K13	50-380048-1	RELAY-GENERATOR LATCH-IN (OPTL)	232	1
M15	60-384038	VOLTMETER-STANDBY GENERATOR OPTL)	240	1
P31A	1-480270-0	PLUG-GLARESHIELD	231	1
P31B	1-480283-0	SOCKET HOUSING	231	1
P31C	60617-1	SOCKET CONTACT	231	1
P46	MS3106A18-1S	PLUG-STANDBY VOLTAGE REGULATOR (OPTL)	232	1
P80A	200838-3	PLUG-GROUNDING BLOCK	231	1
P80B	201224-1	STRAIN RELIEF	231	1

Raytheon Aircraft

BEECH BONANZA WIRING DIAGRAM MANUAL

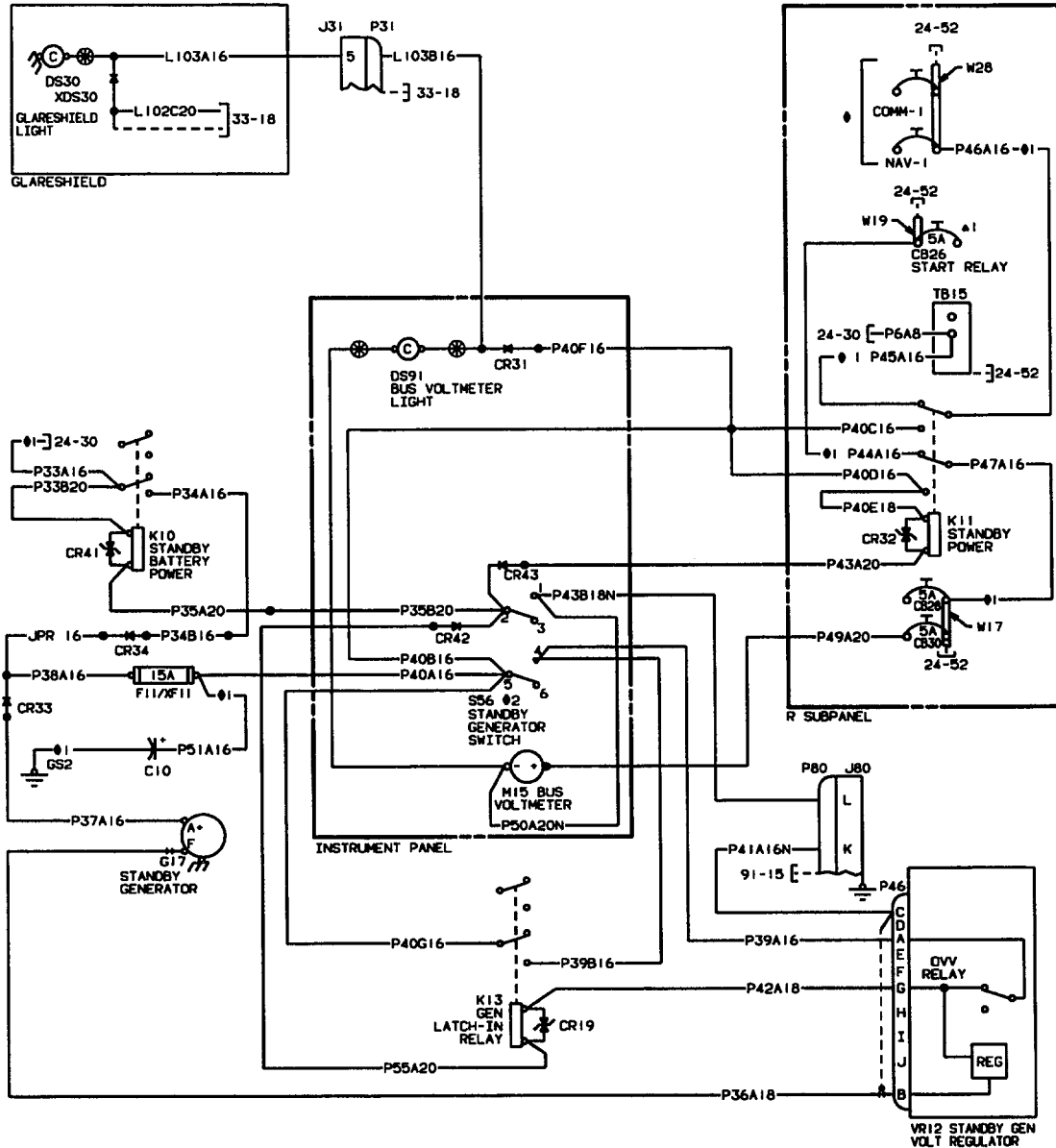

③ ON ACFT CE-1014 & AFT, CJ-156 & AFT, E-2060 & AFT, EA-334 & AFT, D-10404 & AFT, DIODE CR44 IS USED. ON ALL OTHER ACFT WIRE P35B20 TERMINATES AT TERMINAL 2 OF S56.

② S56 SWITCHING
 RESET 1-2 4-5 (MOM)
 ON 1-2 5-6
 OFF 2-3 5-6

④ REFER TO APPLICABLE AVIONICS DMG FOR MODE OF CONNECTION.

① WIRE LENGTH TO BE KEPT TO A MIN.

CE24F
 982528AA

**POWER-EMERGENCY, SINGLE NAVIGATION/COMMUNICATIONS (OPTIONAL)
 E-1787 THRU E-1945, E-1947 THRU E-2103, E-2105 THRU E-2110; CE-934 AND
 AFTER; CJ-156 AND AFTER; D-10358 AND AFTER; EA-174 THRU EA-319, EA-321
 THRU EA-388**

Raytheon Aircraft

BEECH BONANZA WIRING DIAGRAM MANUAL

REFERENCE DESIGNATOR	PART NUMBER	DESCRIPTION	INSTL ZONE	USABLE ON CODE
24-34-02				
P80C	201328-1	SOCKET CONTACT	231	1
P80D	200333-1	SOCKET CONTACT	231	1
P80E	203618-1	JACKSCREW	231	1
S56	35-380053-11	SWITCH-STANDBY GENERATOR POWER (OPTL)	240	1
TB15	MS27212-2-2	TERMINAL BOARD	240	1
VR12	36-380056-3	VOLTAGE REGULATOR-STANDBY GENERATOR	232	3
W17	114931-1-3	BUS BAR (OPTL)	240	1
W19	114931-1-10	BUS BAR (OPTL)	240	1
W28	114931-1-2	BUS BAR (OPTL)	240	1
XDS30	4169-143	LAMPHOLDER	240	1
XF11	4522	FUSE BLOCK (OPTL)	222	1

CODES OF EFFECTIVITY

1. E-1787 THRU E-1945, E-1947 THRU E-2103, E-2105 THRU E-2110; CE-934 AND AFTER; CJ-156 AND AFTER; D-10358 AND AFTER; EA-174 THRU EA-319, EA-321 THRU EA-388
2. E-2060 THRU E-2103 THRU E-2105 THRU E-2110; CE-1014 AND AFTER; CJ-156 AND AFTER; D-10404 AND AFTER; EA-334 THRU EA-388
3. CE-994 AND AFTER

Beechcraft
BONANZA
WIRING DIAGRAM MANUAL

24-40-01

**E-1111, E-1241 THRU E-1945, E-1947 THRU E-2103, E-2105 THRU
E-2110; CE-748, CE-772 AND AFTER; CJ-149 AND AFTER; D-10097,
D-10120 AND AFTER; EA-1 THRU EA-319, EA-321 THRU EA-388**

Beechcraft BONANZA WIRING DIAGRAM MANUAL

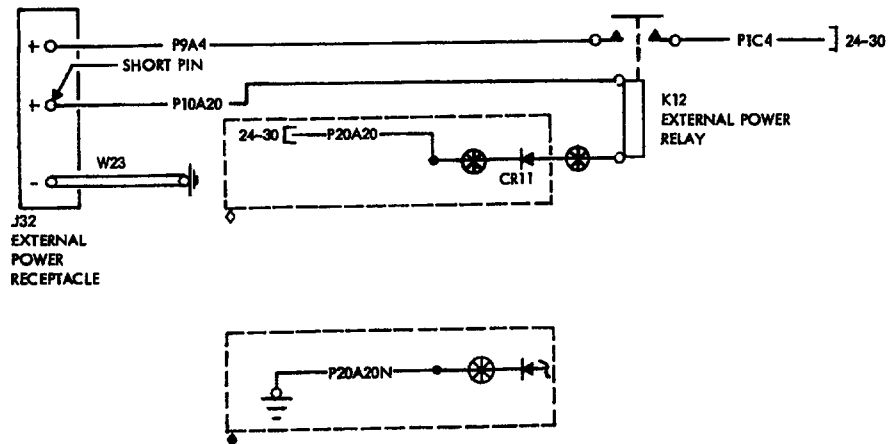

- ◆ ON ACFT E-1111, E-1241 THRU E-1370, EA-1, CE-748, CE-772 THRU CE-815, CJ-149 THRU CJ-155, D-10097, D-10120 THRU D-10178, WIRE IS P20A20N AND GOES TO GROUND STUD GS3
- ON ACFT E-1371 THRU E-1617, EA-2 THRU EA-45, CE-816 THRU CE-891, D-10179 THRU D-10318, WIRE IS P20A20N AND GOES TO GROUND STUD GS4
- ◇ ON ACFT E-1618 & AFTER, EA-46 & AFTER, CE-892 & AFTER, CJ-156 & AFT, D-10319 & AFTER, WIRE IS P20A20 & REFERENCES TO 24-30 AS SHOWN

POWER-EXTERNAL

Raytheon Aircraft

BEECH BONANZA WIRING DIAGRAM MANUAL

REFERENCE DESIGNATOR	PART NUMBER	DESCRIPTION	INSTL ZONE	USABLE ON CODE
24-40-01				
CR11	1N4007	DIODE-EXTERNAL POWER (OPTL) (SUPERSEDED BY 132408-22)	222	2
CR11	132408-22	DIODE-EXTERNAL POWER (OPTL) (SUPERSEDES 1N4007)	222	2
J32	AN2552A3A	RECEPTACLE-EXTERNAL POWER	410	1
K12	70-117224-5	RELAY-EXTERNAL POWER (OPTL)	222	2
W23	95-360012-15	BUS-EXTERNAL POWER (OPTL)	222	2

NOTE

THESE COMPONENTS ARE OPTIONAL
EQUIPMENT ON CE-748, CE-772 THRU
CE-1024 AND CJ-149 THRU CJ-155.

CODES OF EFFECTIVITY

1. E-1111, E-1241 THRU E-1945, E-1947 THRU E-2103, E-2105 THRU E-2110; CE-748, CE-772 AND AFTER; CJ-149 AND AFTER; D-10097, D-10120 AND AFTER; EA-1 THRU EA-319, EA-321 THRU EA-388
2. CE-748, CE-772 AND AFTER; CJ-149 AND AFTER

Beechcraft
BONANZA
WIRING DIAGRAM MANUAL

24-50-01

**E-1111, E-1241 THRU E-1765; CE-748, CE-772 THRU CE-918, CE-920
THRU CE-928; CJ-149 THRU CJ-155; D-10097, D-10120 THRU D-10347,
D-10349 THRU D-10353; EA-1 THRU EA-158**

Beechcraft BONANZA WIRING DIAGRAM MANUAL

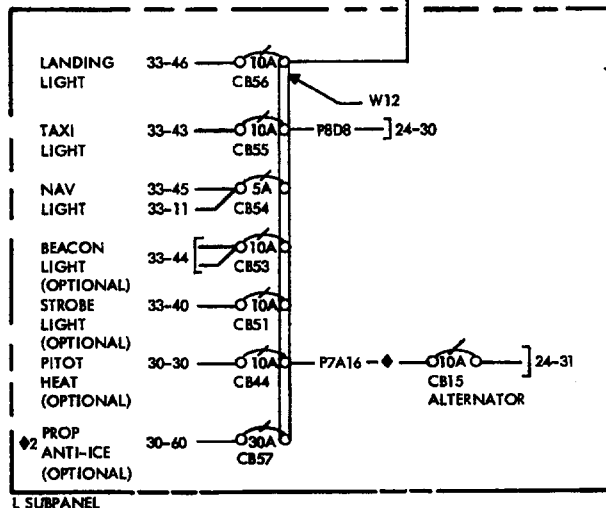
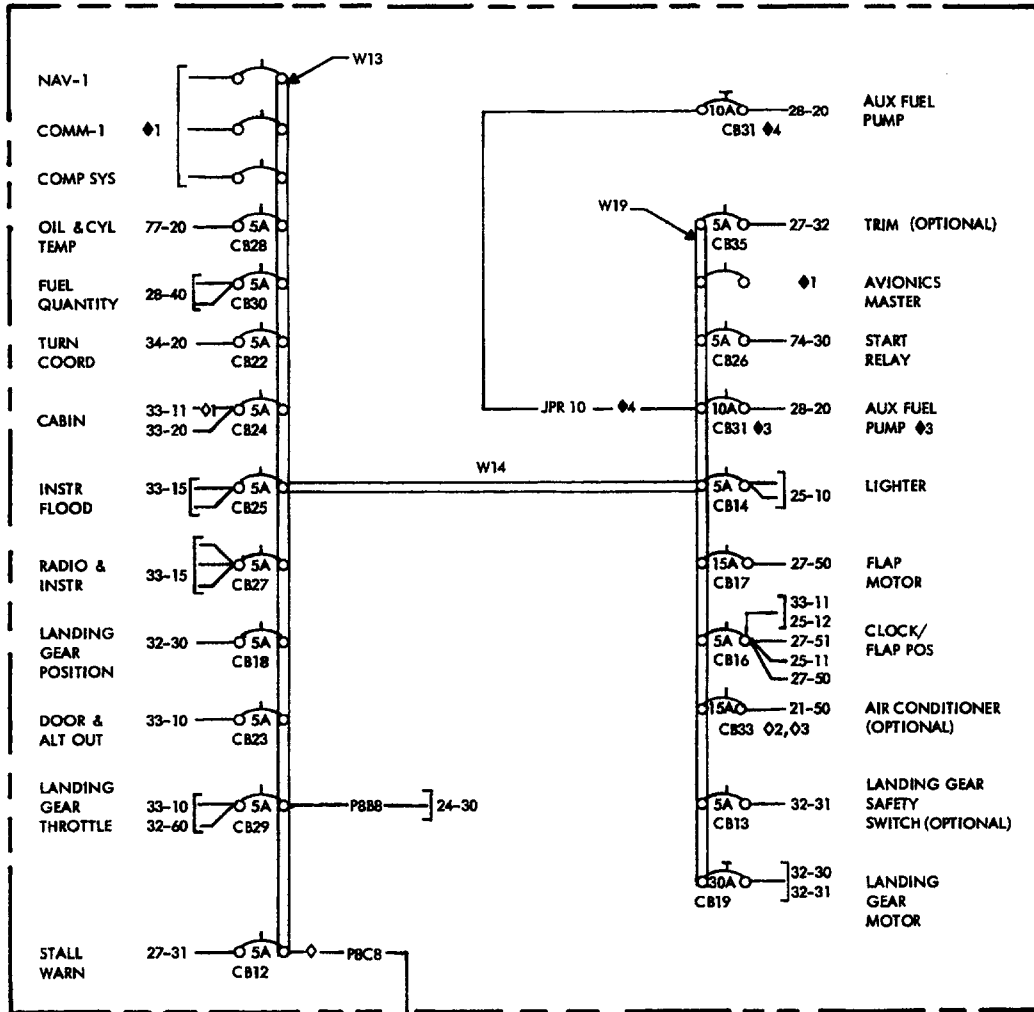

- ◇ ON ACFT E-1518& AFT EA-6& AFT CE-862& AFT CJ-150& AFT AND D-10248& AFT
 - ◇1 ON ACFT E-1111, E-1241 THRU E-1517 EA-1 THRU EA-5 CE-748,CE-772 THRU CE-861, CJ-149, D-10097 AND D-10120 THRU D-10247
 - ◇2 NOT USED ON ACFT EA-1& AFT & CJ-149& AFT PRIOR TO ACFT E-1650, CE-898 & D-10357 CB33 IS 10A
 - ◇ WIRE TO BE ROUTED SEPARATELY BETWEEN BUS AND CIRCUIT BREAKER
 - ◇1 REFER TO APPLICABLE AVIONICS DIAG FOR MODE OF CONNECTION
 - ◇2 ON AIRCRAFT E-1255, E-1258 & AFT EA-1 & AFT CE-789 & AFT, CJ-151 & AFT D-10144 & AFT CB57 IS OPTIONAL
 - ◇3 ON ALL ACFT EXCEPT EA-1 & AFT, CB31 LOCATED ON BUS AS SHOWN
 - ◇4 ON ACFT EA-1 & AFT, CB31 LOCATED AS SHOWN AND JUMPER WIRE IS USED
- NOTE SEE A1 FOR CB TYPE CLARIFICATION

SUBPANELS-LEFT AND RIGHT

Beechcraft
BONANZA
WIRING DIAGRAM MANUAL

REFERENCE DESIGNATOR	PART NUMBER	DESCRIPTION	INSTL ZONE	USABLE ON CODE
24-50-01				
CB12	435-205-104	CIRCUIT BREAKER-STALL WARNING	240	1
CB13	435-205-104	CIRCUIT BREAKER-LANDING GEAR SAFETY SWITCH	240	1
CB14	435-205-104	CIRCUIT BREAKER-CIGARETTE LIGHTER	240	1
CB15	35-380132-13	CIRCUIT BREAKER-ALTERNATOR SWITCH	240	1
CB16	435-205-104	CIRCUIT BREAKER-CLOCK/FLAP POSITION	240	1
CB17	435-215-104	CIRCUIT BREAKER-FLAP MOTOR	240	1
CB18	435-205-104	CIRCUIT BREAKER-LANDING GEAR POSITION	240	1
CB19	CB2330	CIRCUIT BREAKER-LANDING GEAR	240	1
CB22	435-205-104	CIRCUIT BREAKER-TURN COORDINATOR	240	1
CB23	435-205-104	CIRCUIT BREAKER-DOOR AND ALTERNATOR OUT	240	1
CB24	435-205-104	CIRCUIT BREAKER-CABIN AND MAP LIGHT	240	1
CB25	435-205-104	CIRCUIT BREAKER-INSTRUMENT LIGHT	240	1
CB26	435-205-104	CIRCUIT BREAKER-START RELAY	240	1
CB27	435-205-104	CIRCUIT BREAKER-RADIO AND INSTRUMENT LIGHT	240	1
CB28	435-205-104	CIRCUIT BREAKER-OIL AND CYLINDER HEAD TEMP	240	1
CB29	435-205-104	CIRCUIT BREAKER-LANDING GEAR THROTTLE	240	1
CB30	435-205-104	CIRCUIT BREAKER-FUEL QUANTITY INDICATOR	240	1
CB31	435-210-104	CIRCUIT BREAKER-AUXILIARY FUEL PUMP	240	1
CB33	7277-2-10	CIRCUIT BREAKER-AIR CONDITIONER	240	4
CB33	435-210-104	CIRCUIT BREAKER-AIR CONDITIONER (OPTL)	240	3
CB33	435-215-104	CIRCUIT BREAKER-AIR CONDITIONER	240	2
CB33	435-215-104	CIRCUIT BREAKER-AIR CONDITIONER	240	3
CB33	435-210-104	CIRCUIT BREAKER-AIR CONDITIONER (OPTL)	240	2
CB35	435-205-104	CIRCUIT BREAKER-TRIM	240	1
CB44	35-380132-3	CIRCUIT BREAKER-PITOT HEAT	240	1
CB51	35-380132-43	CIRCUIT BREAKER-STROBE LIGHT	240	1
CB53	35-380132-43	CIRCUIT BREAKER-BEACON LIGHT	240	1
CB54	35-380132-41	CIRCUIT BREAKER-NAVIGATION LIGHT	240	1
CB55	35-380132-43	CIRCUIT BREAKER-TAXI LIGHT	240	1
CB56	35-380132-43	CIRCUIT BREAKER-LANDING LIGHT	240	1
CB57	35-380132-9	CIRCUIT BREAKER-PROPELLER ANTI-ICE (OPTL)	240	5
W12	114931-1-6	BUS LIGHT	240	1
W13	114931-1-12	BUS-MAIN	240	1
W14	114931-1-2	BUS BAR-BUS TIE, RIGHT SUBPANEL	240	1
W19	114931-1-10	BUS-SECONDARY	240	1

EFFECTIVITY CODE

1. E-1111, E-1241 THRU E-1765; CE-748, CE-772 THRU CE-918, CE-920 THRU CE-928; CJ-149 THRU CJ-155; D-10097, D-10120 THRU D-10347, D-10349 THRU D-10353; EA-1 THRU EA-158
2. E-1111, E-1241 THRU E-1765; CE-748, CE-772 THRU CE-897; D-10097, D-10120 THRU D-10336
3. CE-898 THRU CE-918, CE-920 THRU CE-928; D-10337 THRU D-10347, D-10349 THRU D-10353
4. E-1111 ONLY
5. E-1255 THRU E-1945, E-1947 THRU E-2103, E-2105 THRU E-2110; CE-789 THRU CE-918, CE-920 THRU CE-928; CJ-151 THRU CJ-155; D-10179 THRU D-10347, D-10349 THRU D-10353; EA-1 THRU EA-158

Beechcraft
BONANZA
WIRING DIAGRAM MANUAL

24-50-02

Configuration 1

**E-1766 THRU E-1945, E-1947 THRU E-2095; CE-919, CE-929 THRU
CE-1023; D-10348, D-10354 THRU D-10403; EA-159 THRU EA-319,
EA-321 THRU EA-377**

Beechcraft BONANZA WIRING DIAGRAM MANUAL

REFERENCE DESIGNATOR	PART NUMBER	DESCRIPTION	USABLE INSTL ON ZONE CODE
24-50-02 (Configuration 1)			
CB12	7277-2-5	CIRCUIT BREAKER-STALL WARNING	240 1
CB14	7277-2-10	CIRCUIT BREAKER-CIGARETTE LIGHTER	240 1
CB15	35-380132-13	CIRCUIT BREAKER-ALTERNATOR SWITCH	240 1
CB17	7271-8-15	CIRCUIT BREAKER-FLAP MOTOR	240 1
CB18	7277-2-5	CIRCUIT BREAKER-LANDING GEAR POSITION	240 1
CB19	7271-8-30	CIRCUIT BREAKER-LANDING GEAR	240 1
CB21	7277-2-5	CIRCUIT BREAKER-FUEL FLOW	240 1
CB22	7277-2-5	CIRCUIT BREAKER-TURN COORDINATOR	240 1
CB23	7277-2-5	CIRCUIT BREAKER-DOOR AND ALTERNATOR OUT	240 1
CB24	7277-2-5	CIRCUIT BREAKER-CABIN AND MAP LIGHT	240 1
CB25	7277-2-5	CIRCUIT BREAKER-INSTRUMENT LIGHT	240 1
CB26	7277-2-5	CIRCUIT BREAKER-START RELAY	240 1
CB27	7277-2-5	CIRCUIT BREAKER-RADIO AND INSTRUMENT LIGHT	240 1
CB28	7277-2-5	CIRCUIT BREAKER-OIL AND CYLINDER HEAD TEMP	240 1
CB29	7277-2-5	CIRCUIT BREAKER-LANDING GEAR THROTTLE	240 1
CB30	7277-2-5	CIRCUIT BREAKER-FUEL QUANTITY INDICATOR	240 1
CB31	7277-2-10	CIRCUIT BREAKER-AUXILIARY FUEL PUMP	240 1
CB33	435-210-104	CIRCUIT BREAKER-AIR CONDITIONER	240 5
CB33	7271-8-15	CIRCUIT BREAKER-AIR CONDITIONER	240 4
CB34	7270-5-10	CIRCUIT BREAKER-VENT AIR BLOWER	240 2
CB34	35-380132-33	CIRCUIT BREAKER-VENT AIR BLOWER	240 3
CB35	7277-2-5	CIRCUIT BREAKER-TRIM	240 1
CB44	35-380132-3	CIRCUIT BREAKER-PITOT HEAT	240 1
CB51	35-380132-43	CIRCUIT BREAKER-STROBE LIGHT	240 1
CB53	35-380132-43	CIRCUIT BREAKER-BEACON LIGHT	240 1
CB54	35-380132-41	CIRCUIT BREAKER-NAVIGATION LIGHT	240 1
CB55	35-380132-43	CIRCUIT BREAKER-TAXI LIGHT	240 1
CB56	35-380132-43	CIRCUIT BREAKER-LANDING LIGHT	240 1
CB57	35-380132-9	CIRCUIT BREAKER-PROPELLER ANTI-ICE (OPTL)	240 6
W12	114931-1-6	BUS LIGHT	240 1
W13	114931-1-12	BUS-MAIN	240 1
W14	114931-1-2	BUS BAR-BUS TIE, RIGHT SUBPANEL	240 1

Beechcraft BONANZA WIRING DIAGRAM MANUAL

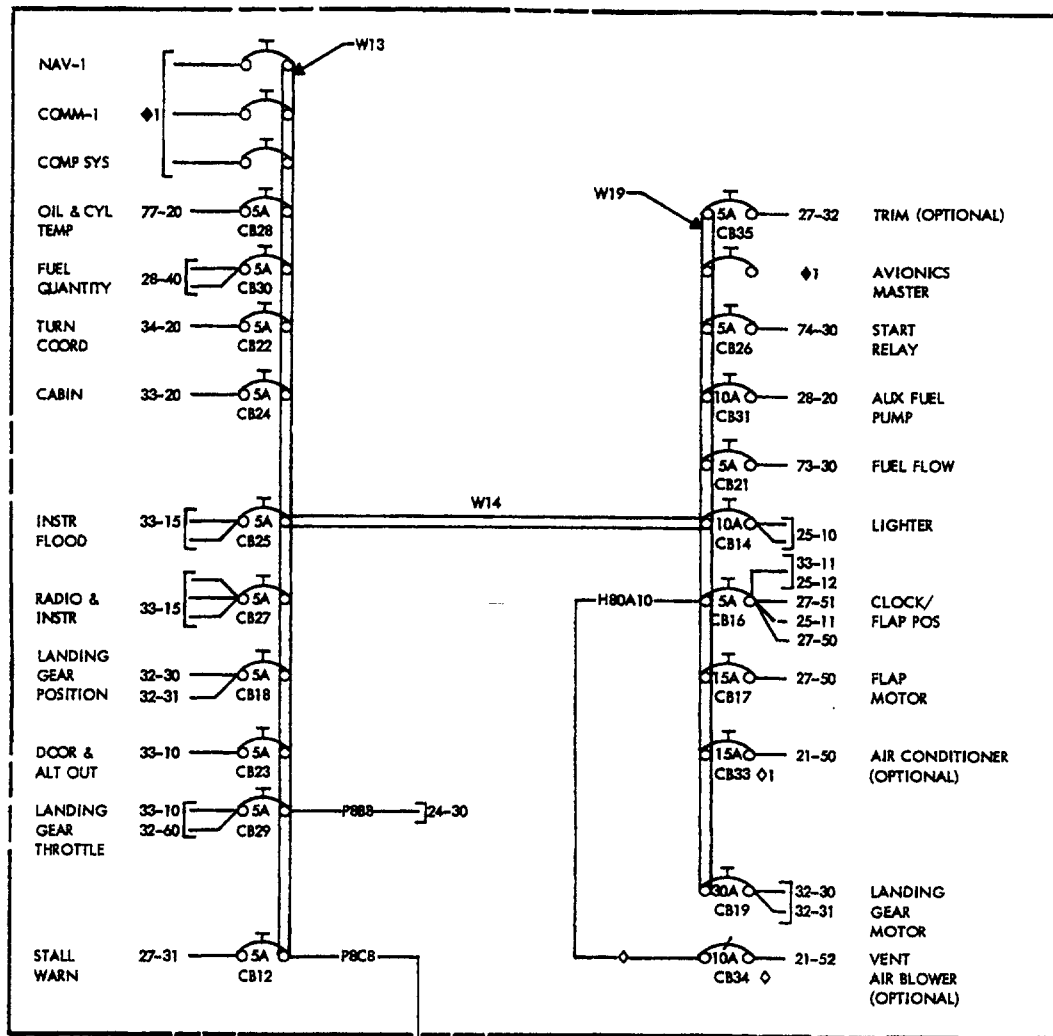

R SUBPANEL ▲1

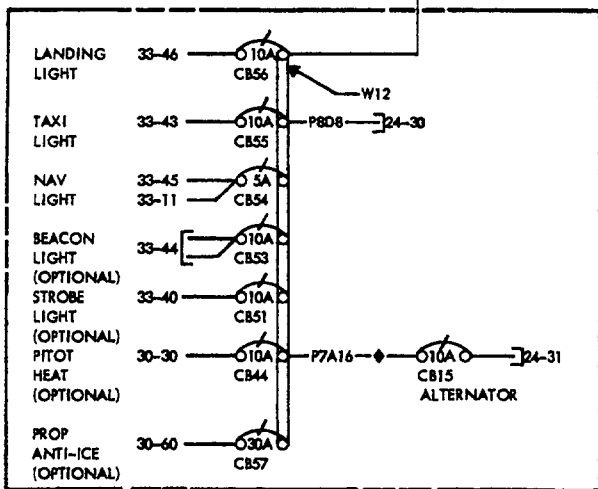

L SUBPANEL

NOTE SEE ▲1 FOR CB TYPE CLARIFICATION

◆ WIRE TO BE ROUTED SEPARATELY BETWEEN BUS AND CIRCUIT BREAKER

◆1 REFER TO APPLICABLE AVIONICS DIAG FOR MODE OF CONNECTION

◇ USED ON ACFT E-1809 & AFT, EA-192 & AFT, CE-941 & AFT, D-10348, D-10364 & AFT ALL AS REQ'D BY WORK ORDER

◇1 CB33 NOT USED ON ACFT EA-1 & AFTER AND CJ-149 & AFTER

**SUBPANEL-LEFT AND RIGHT
(Configuration 1)**

Beechcraft
BONANZA
WIRING DIAGRAM MANUAL

REFERENCE DESIGNATOR	PART NUMBER	DESCRIPTION	USABLE INSTL ON ZONE CODE
		24-50-02 (Configuration 1)	
W19	114931-1-10	BUS-SECONDARY	240 1

EFFECTIVITY CODE

1. E-1766 THRU E-1945, E-1947 THRU E-2095; CE-919, CE-929 THRU CE-1023; D-10348, D-10354 THRU D-10403; EA-159 THRU EA-319, EA-321 THRU EA-377
2. E-1809 THRU E-1945, E-1947 THRU E-1953, E-1955 THRU E-1987; CE-941 THRU CE-989; D-10348, D-10364 THRU D-10389; EA-192 THRU EA-241, EA-243 THRU EA-272
3. E-1954, E-1988 THRU E-2095; CE-990 THRU CE-1023; D-10390 THRU D-10403; EA-242, EA-273 THRU EA-319, EA-321 THRU EA-377
4. E-1766 THRU E-1945, E-1947 THRU E-2095; CE-919, CE-929 THRU CE-1023; D-10354 THRU D-10403
5. D-10348 ONLY
6. E-1766 THRU E-1945, E-1947 THRU E-2095; D-10348, D-10354 THRU D-10403; EA-159 THRU EA-319; EA-321 THRU EA-377

Beechcraft
BONANZA
WIRING DIAGRAM MANUAL

24-50-02

Configuration 2

**E-2096 THRU E-2103, E-2105 THRU E-2110; CE-1024 AND AFTER;
CJ-156 AND AFTER; D-10404 AND AFTER; EA-378 THRU EA-388**

Beechcraft
BONANZA
WIRING DIAGRAM MANUAL

REFERENCE DESIGNATOR	PART NUMBER	DESCRIPTION	USABLE INSTL ON ZONE CODE
24-50-02 (Configuration 2)			
CB12	7277-2-5	CIRCUIT BREAKER-STALL WARNING	240 1
CB14	7277-2-10	CIRCUIT BREAKER-CIGARETTE LIGHTER	240 1
CB15	35-380132-13	CIRCUIT BREAKER-ALTERNATOR SWITCH	240 1
CB16	7277-2-5	CIRCUIT BREAKER-CLOCK/FLAP POSITION	240 1
CB17	7271-8-15	CIRCUIT BREAKER-FLAP MOTOR	240 1
CB18	7277-2-5	CIRCUIT BREAKER-LANDING GEAR POSITION	240 1
CB19	7271-8-30	CIRCUIT BREAKER-LANDING GEAR	240 1
CB21	7277-2-5	CIRCUIT BREAKER-FUEL FLOW	240 1
CB22	7277-2-5	CIRCUIT BREAKER-TURN COORDINATOR	240 1
CB23	7277-2-5	CIRCUIT BREAKER-DOOR AND ALTERNATOR OUT	240 1
CB24	7277-2-5	CIRCUIT BREAKER-CABIN AND MAP LIGHT	240 1
CB25	7277-2-5	CIRCUIT BREAKER-INSTRUMENT LIGHT	240 1
CB26	7277-2-5	CIRCUIT BREAKER-START RELAY	240 1
CB27	7277-2-5	CIRCUIT BREAKER-RADIO AND INSTRUMENT LIGHT	240 1
CB28	7277-2-5	CIRCUIT BREAKER-OIL AND CYLINDER HEAD TEMP	240 1
CB29	7277-2-5	CIRCUIT BREAKER-LANDING GEAR THROTTLE	240 1
CB30	7277-2-5	CIRCUIT BREAKER-FUEL QUANTITY INDICATOR	240 1
CB31	7277-2-5	CIRCUIT BREAKER-AUXILIARY FUEL PUMP	240 1
CB33	7271-8-15	CIRCUIT BREAKER-AIR CONDITIONER	240 2
CB34	35-380132-33	CIRCUIT BREAKER-VENT AIR BLOWER	240 3
CB35	7277-2-5	CIRCUIT BREAKER-TRIM	240 1
CB44	35-380132-3	CIRCUIT BREAKER-PITOT HEAT	240 1
CB51	35-380132-43	CIRCUIT BREAKER-STROBE LIGHT	240 1
CB53	35-380132-43	CIRCUIT BREAKER-BEACON LIGHT	240 1
CB54	35-380132-41	CIRCUIT BREAKER-NAVIGATION LIGHT	240 1
CB55	35-380132-43	CIRCUIT BREAKER-TAXI LIGHT	240 1
CB56	35-380132-43	CIRCUIT BREAKER-LANDING LIGHT	240 1
CB57	35-380132-9	CIRCUIT BREAKER-PROPELLER ANTI-ICE (OPTL)	240 1
CB58	35-380132-39	CIRCUIT BREAKER-STANDBY AIR PUMP	240 3
W12	114931-1-6	BUS LIGHT	240 1
W13	114931-1-12	BUS-MAIN	240 1
W14	114931-1-2	BUS BAR-BUS TIE, RIGHT SUBPANEL	240 1
W19	114931-1-10	BUS-SECONDARY	240 1

EFFECTIVITY CODE

1. E-2096 THRU E-2103, E-2105 THRU E-2110; CE-1024 AND AFTER; CJ-156 AND AFTER; D-10404 AND AFTER; EA-378 THRU EA-388
2. E-2096 THRU E-2103, E-2105 THRU E-2110; CE-1024 AND AFTER; D-10404 AND AFTER
3. CE-1056 AND AFTER; CJ-156 AND AFTER; D-10404 AND AFTER

Beechcraft
BONANZA
WIRING DIAGRAM MANUAL

24-51-01

**E-1424 THRU E-1765; CE-834 THRU CE-918, CE-920 THRU CE-928;
CJ-149 THRU CJ-155; D-10206 THRU D-10347, D-10349 THRU
D-10353; EA-52 THRU EA-158**

Beechcraft
BONANZA
WIRING DIAGRAM MANUAL

REFERENCE DESIGNATOR	PART NUMBER	DESCRIPTION	USABLE	
			INSTL ZONE	ON CODE
24-51-01				
CB12	435-205-104	CIRCUIT BREAKER-STALL WARNING	240	1
CB13	435-205-104	CIRCUIT BREAKER-LANDING GEAR SAFETY SWITCH (OPTL)	240	1
CB14	435-205-104	CIRCUIT BREAKER-CIGARETTE LIGHTER	240	1
CB15	35-380132-13	CIRCUIT BREAKER-ALTERNATOR SWITCH	240	1
CB16	435-205-104	CIRCUIT BREAKER-CLOCK/FLAP POSITION	240	1
CB17	435-215-104	CIRCUIT BREAKER-FLAP MOTOR	240	1
CB18	435-205-104	CIRCUIT BREAKER-LANDING GEAR POSITION	240	1
CB19	CB2330	CIRCUIT BREAKER-LANDING GEAR	240	1
CB22	435-205-104	CIRCUIT BREAKER-TURN COORDINATOR	240	1
CB23	435-205-104	CIRCUIT BREAKER-DOOR AND ALTERNATOR OUT	240	1
CB24	435-205-104	CIRCUIT BREAKER-CABIN AND MAP LIGHT	240	1
CB25	435-205-104	CIRCUIT BREAKER-INSTRUMENT LIGHT	240	1
CB26	435-205-104	CIRCUIT BREAKER-START RELAY	240	1
CB27	435-205-104	CIRCUIT BREAKER-RADIO AND INSTRUMENT LIGHT	240	1
CB28	435-205-104	CIRCUIT BREAKER-OIL AND CYLINDER HEAD TEMP	240	1
CB29	435-205-104	CIRCUIT BREAKER-LANDING GEAR THROTTLE	240	1
CB30	435-205-104	CIRCUIT BREAKER-FUEL QUANTITY INDICATOR	240	1
CB31	435-210-104	CIRCUIT BREAKER-AUXILIARY FUEL PUMP	240	1
CB33	435-210-104	CIRCUIT BREAKER-AIR CONDITIONER (OPTL)	240	3
CB35	435-205-104	CIRCUIT BREAKER-TRIM (OPTL)	240	1
CB44	35-380132-3	CIRCUIT BREAKER-PITOT HEAT (OPTL)	240	1
CB51	35-380132-43	CIRCUIT BREAKER-STROBE LIGHT (OPTL)	240	1
CB53	35-380132-43	CIRCUIT BREAKER-BEACON LIGHT (OPTL)	240	1
CB54	35-380132-41	CIRCUIT BREAKER-NAVIGATION LIGHT	240	1
CB55	35-380132-43	CIRCUIT BREAKER-TAXI LIGHT	240	1
CB56	35-380132-43	CIRCUIT BREAKER-LANDING LIGHT	240	1
CB57	35-380132-9	CIRCUIT BREAKER-PROPELLER ANTI-ICE (OPTL)	240	2
W12	114931-1-6	BUS LIGHT	240	1
W14	114931-1-2	BUS BAR-BUS TIE, RIGHT SUBPANEL	240	1
W16	114931-1-4	BUS BAR (OPTL)	240	1
W17	114931-1-3	BUS BAR (OPTL)	240	1
W18	114931-1-7	BUS BAR (OPTL)	240	1
W19	114931-1-10	BUS-SECONDARY	240	1
W27	114931-1-4	BUS BAR (OPTL)	240	1

EFFECTIVITY CODE

1. E-1424 THRU E-1765; CE-834 THRU CE-918, CE-920 THRU CE-928; CJ-149 THRU CJ-155; D-10206 THRU D-10347, D-10349 THRU D-10353; EA-52 THRU EA-158
2. E-1424 THRU E-1765; CE-834 THRU CE-918, CE-920 THRU CE-928; CJ-151 THRU CJ-155; D-10206 THRU D-10347, D-10349 THRU D-10353; EA-52 THRU EA-158
3. E-1424 THRU E-1765; CE-834 THRU CE-897; D-10206 THRU D-10336

Beechcraft
BONANZA
WIRING DIAGRAM MANUAL

24-51-02

Configuration 1

**E-1766 THRU E-1945, E-1947 THRU E-2095; CE-919, CE-929 THRU
CE-1023; CJ-156 AND AFTER; D-10348, D-10354 THRU D-10403;
EA-159 THRU EA-319, EA-321 THRU EA-377**

Beechcraft
BONANZA
WIRING DIAGRAM MANUAL

REFERENCE DESIGNATOR	PART NUMBER	DESCRIPTION	USABLE INSTL ON ZONE CODE
24-51-02 (Configuration 1)			
CB12	435-205-104	CIRCUIT BREAKER-STALL WARNING	240 1
CB14	7277-2-10	CIRCUIT BREAKER-CIGARETTE LIGHTER	240 1
CB15	35-380132-13	CIRCUIT BREAKER-ALTERNATOR SWITCH	240 1
CB16	435-205-104	CIRCUIT BREAKER-CLOCK/FLAP POSITION	240 1
CB17	435-215-104	CIRCUIT BREAKER-FLAP MOTOR	240 1
CB18	435-205-104	CIRCUIT BREAKER-LANDING GEAR POSITION	240 1
CB19	CB2330	CIRCUIT BREAKER-LANDING GEAR	240 1
CB21	7277-2-5	CIRCUIT BREAKER-FUEL FLOW	240 1
CB22	435-205-104	CIRCUIT BREAKER-TURN COORDINATOR	240 1
CB23	435-205-104	CIRCUIT BREAKER-DOOR AND ALTERNATOR OUT	240 1
CB24	435-205-104	CIRCUIT BREAKER-CABIN AND MAP LIGHT	240 1
CB25	435-205-104	CIRCUIT BREAKER-INSTRUMENT LIGHT	240 1
CB26	435-205-104	CIRCUIT BREAKER-START RELAY	240 1
CB27	435-205-104	CIRCUIT BREAKER-RADIO AND INSTRUMENT LIGHT	240 1
CB28	435-205-104	CIRCUIT BREAKER-OIL AND CYLINDER HEAD TEMP	240 1
CB29	435-205-104	CIRCUIT BREAKER-LANDING GEAR THROTTLE	240 1
CB30	435-205-104	CIRCUIT BREAKER-FUEL QUANTITY INDICATOR	240 1
CB31	435-210-104	CIRCUIT BREAKER-AUXILIARY FUEL PUMP	240 1
CB33	435-210-104	CIRCUIT BREAKER-AIR CONDITIONER (OPTL)	240 5
CB33	435-215-104	CIRCUIT BREAKER-AIR CONDITIONER	240 7
CB33	7271-8-15	CIRCUIT BREAKER-AIR CONDITIONER	240 6
CB34	35-380132-33	CIRCUIT BREAKER-VENT AIR BLOWER	240 4
CB34	7270-5-10	CIRCUIT BREAKER-VENT AIR BLOWER (OPTL)	240 3
CB35	435-205-104	CIRCUIT BREAKER-TRIM (OPTL)	240 1
CB44	35-380132-3	CIRCUIT BREAKER-PITOT HEAT (OPTL)	240 1
CB51	35-380132-43	CIRCUIT BREAKER-STROBE LIGHT (OPTL)	240 1
CB53	35-380132-43	CIRCUIT BREAKER-BEACON LIGHT (OPTL)	240 1
CB54	35-380132-41	CIRCUIT BREAKER-NAVIGATION LIGHT	240 1
CB55	35-380132-43	CIRCUIT BREAKER-TAXI LIGHT	240 1
CB56	35-380132-43	CIRCUIT BREAKER-LANDING LIGHT	240 1
CB57	35-380132-9	CIRCUIT BREAKER-PROPELLER ANTI-ICE (OPTL)	240 1
CB58	35-380132-39	CIRCUIT BREAKER-STANDBY AIR PUMP	240 2
W12	114931-1-6	BUS LIGHT	240 1
W14	114931-1-2	BUS BAR-BUS TIE, RIGHT SUBPANEL	240 1
W16	114931-1-4	BUS BAR (OPTL)	240 1
W17	114931-1-3	BUS BAR (OPTL)	240 1
W18	114931-1-7	BUS BAR (OPTL)	240 1
W19	114931-1-10	BUS-SECONDARY	240 1

Beechcraft BONANZA WIRING DIAGRAM MANUAL

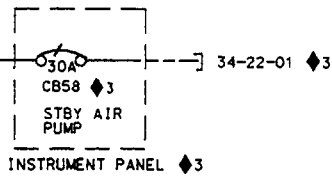
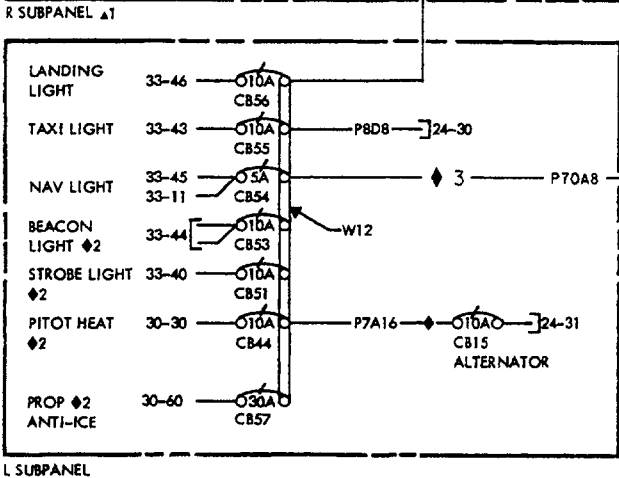
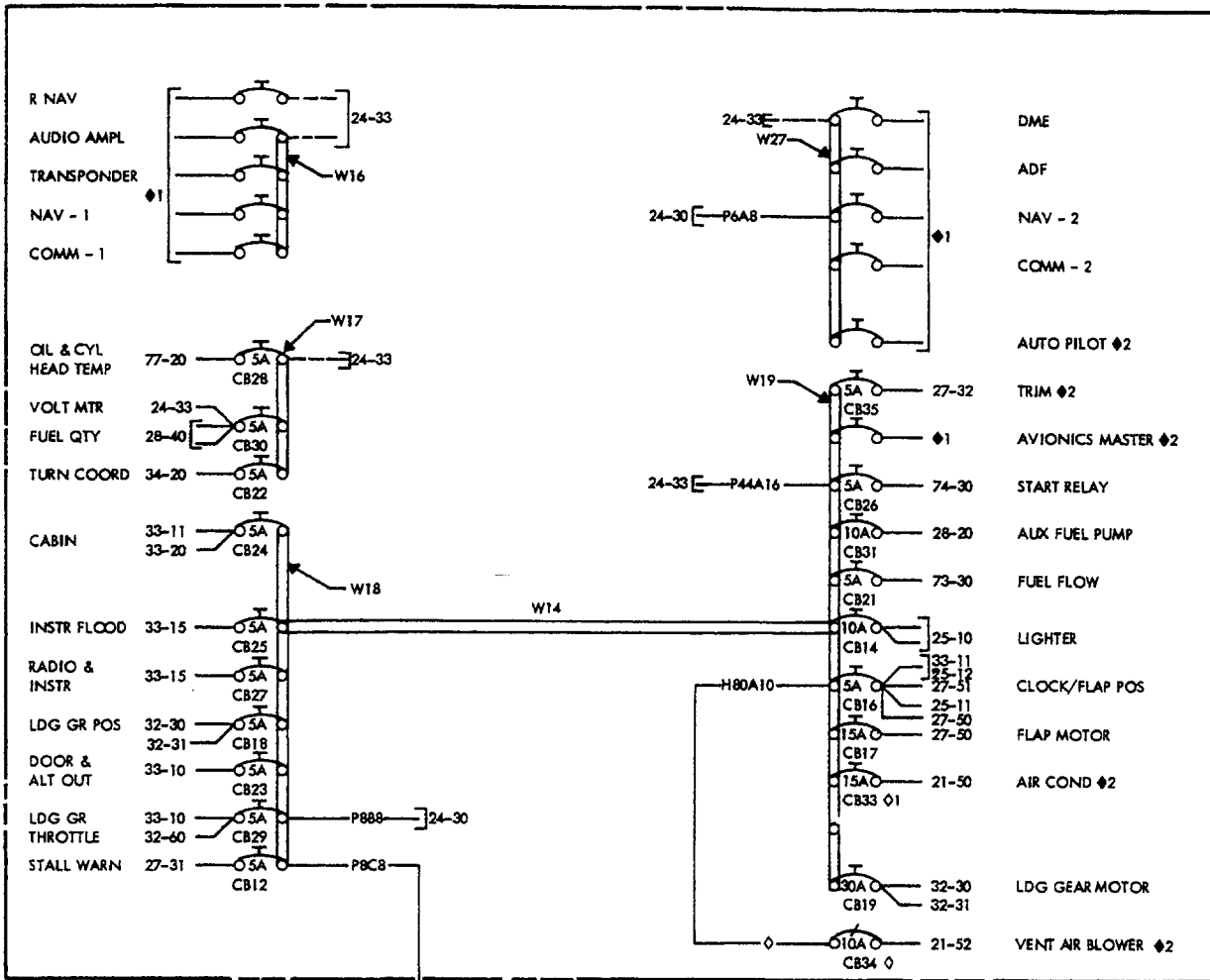

- ◆ 3 WIRE AND CIRCUIT BREAKER ARE USED AT EFF CE-1056 & AFT, D-10404 & AFT, AND CJ-156 & AFT
- ◆ 2 OPTIONAL.
- ◆ 1 REFER TO APPLICABLE AVIONICS DIAG FOR MODE OF CONNECTION.
- ◆ WIRE TO BE ROUTED SEPARATELY BETWEEN BUS & CIRCUIT BREAKER.

◆ ON ACFT E-1809 & AFT; EA-192 & AFT; CE-941 & AFT; D-10348, D-10364 & AFT, ALL AS REQUIRED BY WORK ORDER.
 ◆ 1 CB33 NOT USED ON ACFT CJ-149 & AFTER.

NOTE: SEE Δ1 FOR CB TYPE CLARIFICATION.

POWER-EMERGENCY, DUAL NAVIGATION/COMMUNICATIONS (OPTIONAL) (Configuration 1)

Beechcraft
BONANZA
WIRING DIAGRAM MANUAL

REFERENCE DESIGNATOR	PART NUMBER	DESCRIPTION	USABLE INSTL ON ZONE CODE
		24-51-02 (Configuration 1)	
W27	114931-1-4	BUS BAR (OPTL)	240 1

EFFECTIVITY CODE

1. E-1766 THRU E-1945, E-1947 THRU E-2095; CE-919, CE-929 THRU CE-1023; CJ-156 AND AFTER; D-10348, D-10354 THRU D-10403; EA-159 THRU EA-319, EA-321 THRU EA-388
2. CJ-156 AND AFTER
3. E-1809 THRU E-1945, E-1947 THRU E-1953; CE-941 THRU CE-989; D-10348, D-10364 THRU D-10389; EA-192 THRU EA-241, EA-243 THRU EA-272
4. E-1954, E-1988 THRU E-2103, E-2105 THRU E-2110; CE-990 THRU CE-1023; D-10390 THRU D-10403
5. E-1766 THRU E-1945, E-1947 THRU E-2095
6. E-1766 THRU E-1945, E-1947 THRU E-2095; CE-919, CE-929 THRU CE-1023; D-10354 THRU D-10403
7. D-10337 THRU D-10353

Beechcraft
BONANZA
WIRING DIAGRAM MANUAL

24-51-02

Configuration 2

**E-2096 THRU E-2103, E-2105 THRU E-2110; CE-1024 AND AFTER;
D-10404 AND AFTER; EA-378 THRU EA-388**

Beechcraft BONANZA WIRING DIAGRAM MANUAL

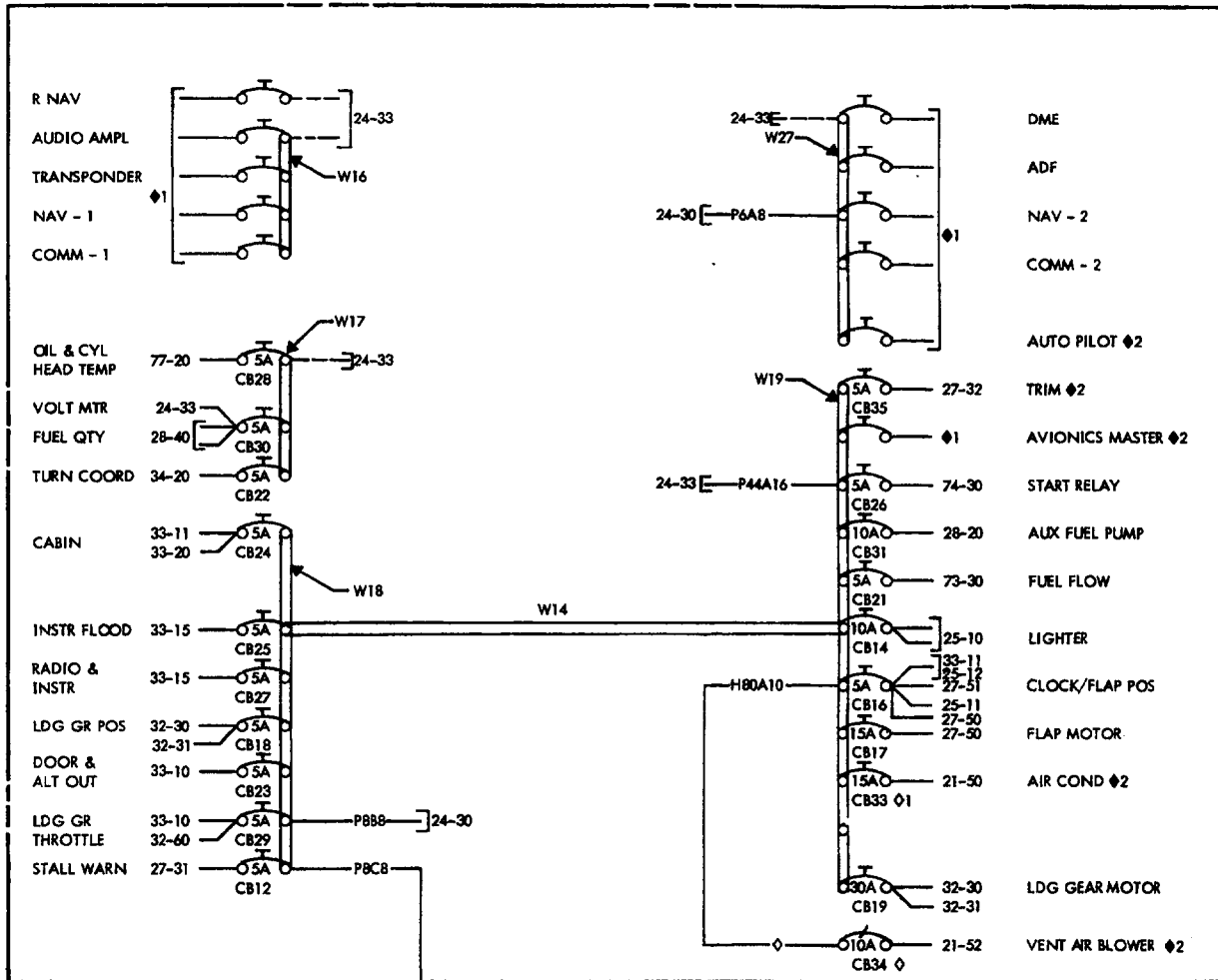

R SUBPANEL ▲1

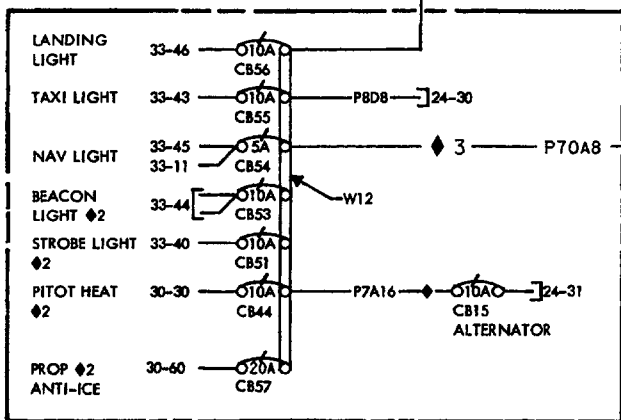

L SUBPANEL

- ◆ WIRE TO BE ROUTED SEPARATELY BETWEEN BUS & CIRCUIT BREAKER.
- ◆1 REFER TO APPLICABLE AVIONICS DIAG FOR MODE OF CONNECTION.
- ◆2 OPTIONAL.
- ◇ ON ACFT E-1809 & AFT; EA-192 & AFT; CE-941 & AFT; D-10348, D-10364 & AFT, ALL AS REQUIRED BY WORK ORDER.

NOTE: SEE ▲1 FOR CB TYPE CLARIFICATION.

◇1 CB33 NOT USED ON ACFT CJ-149 & AFT.

◆3 ON ACFT CE-1056 & AFT, D-10404 & AFT, WIRE AND CIRCUIT BREAKER ARE USED

POWER-EMERGENCY, DUAL NAVIGATION COMMUNICATIONS (OPTIONAL) (Configuration 2)

Beechcraft BONANZA WIRING DIAGRAM MANUAL

REFERENCE DESIGNATOR	PART NUMBER	DESCRIPTION	USABLE INSTL ON ZONE CODE
24-51-02 (Configuration 2)			
CB12	435-205-104	CIRCUIT BREAKER-STALL WARNING	240 1
CB14	7277-2-10	CIRCUIT BREAKER-CIGARETTE LIGHTER	240 1
CB15	35-380132-13	CIRCUIT BREAKER-ALTERNATOR SWITCH	240 1
CB16	435-205-104	CIRCUIT BREAKER-CLOCK/FLAP POSITION	240 1
CB17	435-215-104	CIRCUIT BREAKER-FLAP MOTOR	240 1
CB18	435-205-104	CIRCUIT BREAKER-LANDING GEAR POSITION	240 1
CB19	CB2330	CIRCUIT BREAKER-LANDING GEAR	240 1
CB21	7277-2-5	CIRCUIT BREAKER-FUEL FLOW	240 1
CB22	435-205-104	CIRCUIT BREAKER-TURN COORDINATOR	240 1
CB23	435-205-104	CIRCUIT BREAKER-DOOR AND ALTERNATOR OUT	240 1
CB24	435-205-104	CIRCUIT BREAKER-CABIN AND MAP LIGHT	240 1
CB25	435-205-104	CIRCUIT BREAKER-INSTRUMENT LIGHT	240 1
CB26	435-205-104	CIRCUIT BREAKER-START RELAY	240 1
CB27	435-205-104	CIRCUIT BREAKER-RADIO AND INSTRUMENT LIGHT	240 1
CB28	435-205-104	CIRCUIT BREAKER-OIL AND CYLINDER HEAD TEMP	240 1
CB29	435-205-104	CIRCUIT BREAKER-LANDING GEAR THROTTLE	240 1
CB30	435-205-104	CIRCUIT BREAKER-FUEL QUANTITY INDICATOR	240 1
CB31	435-210-104	CIRCUIT BREAKER-AUXILIARY FUEL PUMP (OPTL)	240 1
CB33	435-210-104	CIRCUIT BREAKER-AIR CONDITIONER (OPTL)	240 2
CB33	7271-8-15	CIRCUIT BREAKER-AIR CONDITIONER (OPTL)	240 4
CB34	35-380132-33	CIRCUIT BREAKER-VENT AIR BLOWER (OPTL)	240 1
CB35	435-205-104	CIRCUIT BREAKER-TRIM (OPTL)	240 1
CB44	35-380132-3	CIRCUIT BREAKER-PITOT HEAT (OPTL)	240 1
CB51	35-380132-43	CIRCUIT BREAKER-STROBE LIGHT (OPTL)	240 1
CB53	35-380132-43	CIRCUIT BREAKER-BEACON LIGHT (OPTL)	240 1
CB54	35-380132-41	CIRCUIT BREAKER-NAVIGATION LIGHT	240 1
CB55	35-380132-43	CIRCUIT BREAKER-TAXI LIGHT	240 1
CB56	35-380132-43	CIRCUIT BREAKER-LANDING LIGHT	240 1
CB57	35-380132-9	CIRCUIT BREAKER-PROPELLER ANTI-ICE (OPTL)	240 1
CB58	35-380132-39	CIRCUIT BREAKER-STANDBY AIR PUMP	240 3
W12	114931-1-6	BUS LIGHT	240 1
W14	114931-1-2	BUS BAR-BUS TIE, RIGHT SUBPANEL	240 1
W16	114931-1-4	BUS BAR (OPTL)	240 1
W17	114931-1-3	BUS BAR (OPTL)	240 1
W18	114931-1-7	BUS BAR (OPTL)	240 1
W19	114931-1-10	BUS-SECONDARY	240 1
W27	114931-1-4	BUS BAR (OPTL)	240 1

EFFECTIVITY CODE

1. E-2096 THRU E-2103, E-2105 THRU E-2110; CE-1024 AND AFTER; D-10404 AND AFTER; EA-378 THRU EA-388
2. E-2096 THRU E-2103, E-2105 THRU E-2110
3. CE-1056 AND AFTER; CJ-156 AND AFTER; D-10404 AND AFTER
4. E-2096 THRU E-2103, E-2105 THRU E-2110; CE-1024 AND AFTER; D-10404 AND AFTER

Beechcraft
BONANZA
WIRING DIAGRAM MANUAL

24-52-01

**E-1424 THRU E-1765; CE-834 THRU CE-918, CE-920 THRU CE-928;
CJ-149 THRU CJ-155; D-10206 THRU D-10347, D-10349 THRU
D-10353; EA-52 THRU EA-158**

Beechcraft BONANZA WIRING DIAGRAM MANUAL

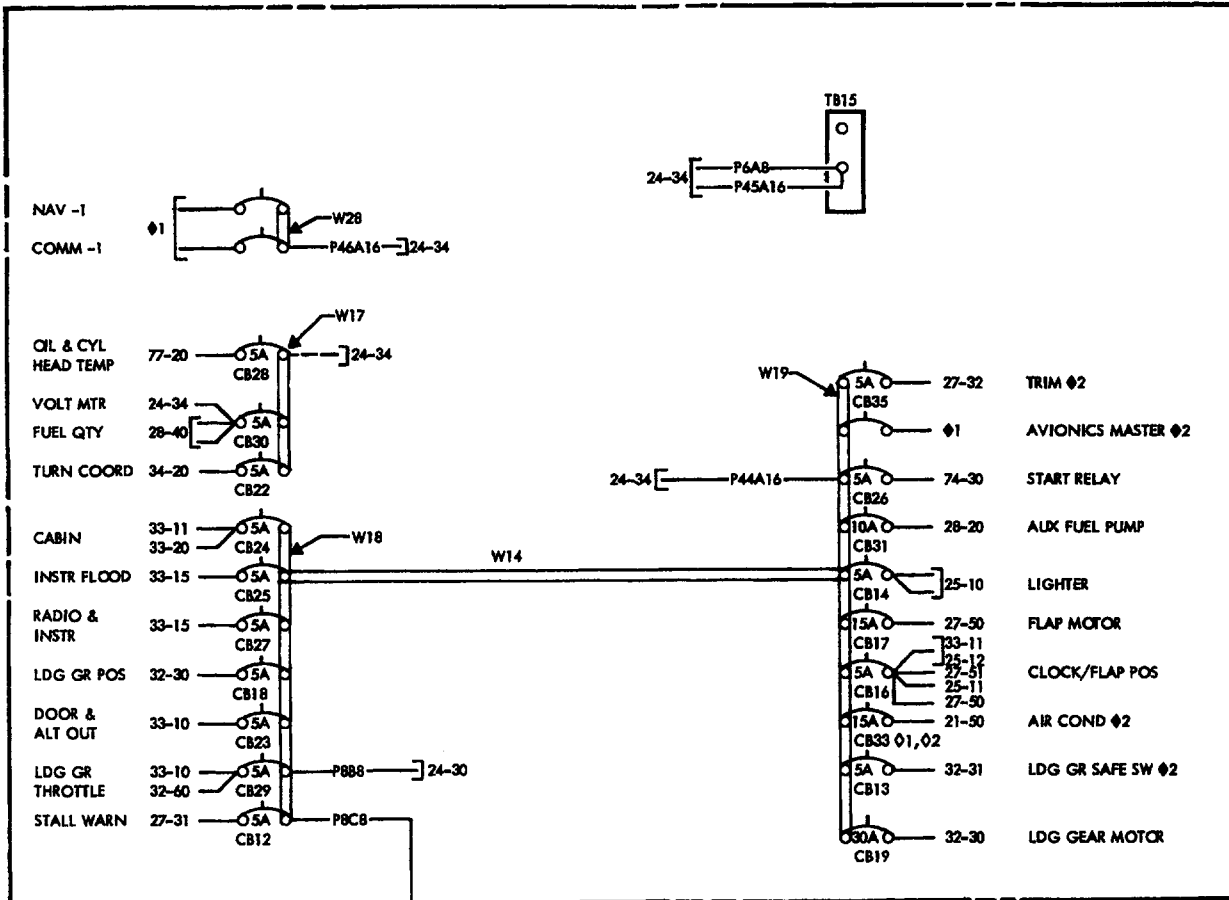

R SUBPANEL Δ1

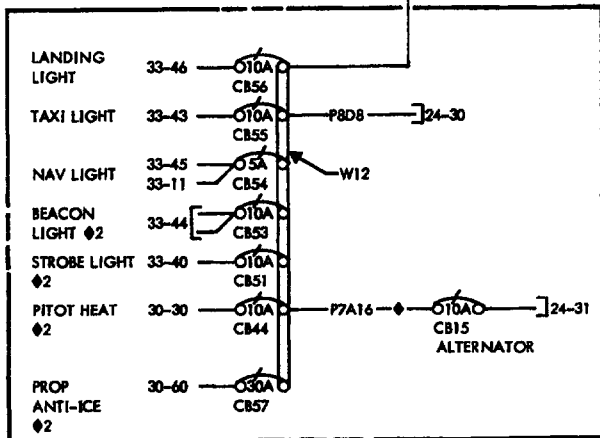

L SUBPANEL

- ◆ WIRE TO BE ROUTED SEPARATELY BETWEEN BUS & CIRCUIT BREAKER.
 - ◆1 REFER TO APPLICABLE AVIONICS DIAG FOR MODE OF CONNECTION.
 - ◆2 OPTIONAL.
- NOTE: SEE Δ1 FOR CB TYPE CLARIFICATION.
- ◆1 CB33 NOT USED ON ACFT CJ-149& AFTER.
 - ◆2 PRIOR TO E-1650; CE-898; D-10337 CB33 IS 10A.

POWER-EMERGENCY, SINGLE NAVIGATION/COMMUNICATIONS (OPTIONAL)

Beechcraft
BONANZA
WIRING DIAGRAM MANUAL

REFERENCE DESIGNATOR	PART NUMBER	DESCRIPTION	USABLE	
			INSTL ZONE	ON CODE
24-52-01				
CB12	435-205-104	CIRCUIT BREAKER-STALL WARNING	240	1
CB13	435-205-104	CIRCUIT BREAKER-LANDING GEAR SAFETY SWITCH	240	1
CB14	435-205-104	CIRCUIT BREAKER-CIGARETTE LIGHTER	240	1
CB15	35-380132-13	CIRCUIT BREAKER-ALTERNATOR SWITCH	240	1
CB16	435-205-104	CIRCUIT BREAKER-CLOCK/FLAP POSITION	240	1
CB17	435-215-104	CIRCUIT BREAKER-FLAP MOTOR	240	1
CB18	435-205-104	CIRCUIT BREAKER-LANDING GEAR POSITION	240	1
CB19	CB2330	CIRCUIT BREAKER-LANDING GEAR	240	1
CB22	435-205-104	CIRCUIT BREAKER-TURN COORDINATOR	240	1
CB23	435-205-104	CIRCUIT BREAKER-DOOR AND ALTERNATOR OUT	240	1
CB24	435-205-104	CIRCUIT BREAKER-CABIN AND MAP LIGHT	240	1
CB25	435-205-104	CIRCUIT BREAKER-INSTRUMENT LIGHT	240	1
CB26	435-205-104	CIRCUIT BREAKER-START RELAY	240	1
CB27	435-205-104	CIRCUIT BREAKER-RADIO AND INSTRUMENT LIGHT	240	1
CB28	435-205-104	CIRCUIT BREAKER-OIL AND CYLINDER HEAD TEMP	240	1
CB29	435-205-104	CIRCUIT BREAKER-LANDING GEAR THROTTLE	240	1
CB30	435-205-104	CIRCUIT BREAKER-FUEL QUANTITY INDICATOR	240	1
CB31	435-210-104	CIRCUIT BREAKER-AUXILIARY FUEL PUMP	240	1
CB33	435-210-104	CIRCUIT BREAKER-AIR CONDITIONER (OPTL)	240	3
CB33	7271-8-15	CIRCUIT BREAKER-AIR CONDITIONER (OPTL)	240	4
CB35	435-205-104	CIRCUIT BREAKER-TRIM (OPTL)	240	1
CB44	35-380132-3	CIRCUIT BREAKER-PITOT HEAT (OPTL)	240	1
CB51	35-380132-43	CIRCUIT BREAKER-STROBE LIGHT (OPTL)	240	1
CB53	35-380132-43	CIRCUIT BREAKER-BEACON LIGHT (OPTL)	240	1
CB54	35-380132-41	CIRCUIT BREAKER-NAVIGATION LIGHT	240	1
CB55	35-380132-43	CIRCUIT BREAKER-TAXI LIGHT	240	1
CB56	35-380132-43	CIRCUIT BREAKER-LANDING LIGHT	240	1
CB57	35-380132-9	CIRCUIT BREAKER-PROPELLER ANTI-ICE (OPTL)	240	2
TB15	MS27212-2-2	TERMINAL BOARD (OPTL)	240	1
W12	114931-1-6	BUS LIGHT	240	1
W14	114931-1-2	BUS BAR-BUS TIE, RIGHT SUBPANEL	240	1
W17	114931-1-3	BUS BAR (OPTL)	240	1
W18	114931-1-7	BUS BAR (OPTL)	240	1
W19	114931-1-10	BUS-SECONDARY	240	1
W28	114931-1-2	BUS BAR (OPTL)	240	1

EFFECTIVITY CODE

1. E-1424 THRU E-1765; CE-834 THRU CE-918, CE-920 THRU CE-928; CJ-149 THRU CJ-155; D-10206 THRU D-10347, D-10349 THRU D-10353; EA-52 THRU EA-158
2. E-1424 THRU E-1765; CE-834 THRU CE-918, CE-920 THRU CE-928; CJ-151 THRU CJ-155; D-10206 THRU D-10347, D-10349 THRU D-10353; EA-52 THRU EA-158
3. E-1424 THRU E-1765; CE-834 THRU CE-897; D-10206 THRU D-10336
4. CE-898 THRU CE-918, CE-920 THRU CE-928; D-10337 THRU D-10347, D-10349 THRU D-10353

Beechcraft
BONANZA
WIRING DIAGRAM MANUAL

24-52-02

Configuration 1

**E-1766 THRU E-1945, E-1947 THRU E-2095; CE-919, CE-929 THRU
CE-1023; CJ-156 AND AFTER; D-10348, D-10354 THRU D-10403;
EA-159 THRU EA-319, EA-321 THRU EA-377**

Beechcraft BONANZA WIRING DIAGRAM MANUAL

REFERENCE DESIGNATOR	PART NUMBER	DESCRIPTION	USABLE	
			INSTL ZONE	ON CODE
24-52-02 (Configuration 1)				
CB12	7277-2-5	CIRCUIT BREAKER-STALL WARNING	240	1
CB13	7277-2-5	CIRCUIT BREAKER-LANDING GEAR SAFETY SWITCH (OPTL)	240	1
CB14	7277-2-10	CIRCUIT BREAKER-CIGARETTE LIGHTER	240	1
CB15	35-380132-13	CIRCUIT BREAKER-ALTERNATOR SWITCH	240	1
CB16	7277-2-5	CIRCUIT BREAKER-CLOCK/FLAP POSITION	240	1
CB17	MS24510-15	CIRCUIT BREAKER-FLAP MOTOR	240	1
CB18	7277-2-5	CIRCUIT BREAKER-LANDING GEAR POSITION	240	1
CB19	MS24510-30	CIRCUIT BREAKER-LANDING GEAR	240	1
CB21	7277-2-5	CIRCUIT BREAKER-FUEL FLOW	240	1
CB22	7277-2-5	CIRCUIT BREAKER-TURN COORDINATOR	240	1
CB23	7277-2-5	CIRCUIT BREAKER-DOOR AND ALTERNATOR OUT	240	1
CB24	7277-2-5	CIRCUIT BREAKER-CABIN AND MAP LIGHT	240	1
CB25	7277-2-5	CIRCUIT BREAKER-INSTRUMENT LIGHT	240	1
CB26	7277-2-5	CIRCUIT BREAKER-START RELAY	240	1
CB27	7277-2-5	CIRCUIT BREAKER-RADIO AND INSTRUMENT LIGHT	240	1
CB28	7277-2-5	CIRCUIT BREAKER-OIL AND CYLINDER HEAD TEMP	240	1
CB29	7277-2-5	CIRCUIT BREAKER-LANDING GEAR THROTTLE	240	1
CB30	7277-2-5	CIRCUIT BREAKER-FUEL QUANTITY INDICATOR	240	1
CB31	7277-2-10	CIRCUIT BREAKER-AUXILIARY FUEL PUMP	240	1
CB33	435-210-104	CIRCUIT BREAKER-AIR CONDITIONER (OPTL)	240	4
CB33	7271-8-15	CIRCUIT BREAKER-AIR CONDITIONER (OPTL)	240	5
CB34	7270-5-10	CIRCUIT BREAKER-VENT AIR BLOWER	240	2
CB34	35-380132-33	CIRCUIT BREAKER-VENT AIR BLOWER	240	3
CB35	7277-2-5	CIRCUIT BREAKER-TRIM (OPTL)	240	1
CB44	35-380132-3	CIRCUIT BREAKER-PITOT HEAT (OPTL)	240	1
CB51	35-380132-43	CIRCUIT BREAKER-STROBE LIGHT (OPTL)	240	1
CB53	35-380132-43	CIRCUIT BREAKER-BEACON LIGHT (OPTL)	240	1
CB54	35-380132-41	CIRCUIT BREAKER-NAVIGATION LIGHT	240	1
CB55	35-380132-43	CIRCUIT BREAKER-TAXI LIGHT	240	1
CB56	35-380132-43	CIRCUIT BREAKER-LANDING LIGHT	240	1
CB57	35-380132-9	CIRCUIT BREAKER-PROPELLER ANTI-ICE (OPTL)	240	1
CB58	35-380132-39	CIRCUIT BREAKER-STANDBY AIR PUMP	240	6
TB15	MS27212-2-2	TERMINAL BOARD (OPTL)	240	1
W12	114931-1-6	BUS LIGHT	240	1
W14	114931-1-2	BUS BAR-BUS TIE, RIGHT SUBPANEL	240	1
W18	114931-1-7	BUS BAR (OPTL)	240	1
W19	114931-1-10	BUS-SECONDARY	240	1

Beechcraft BONANZA WIRING DIAGRAM MANUAL

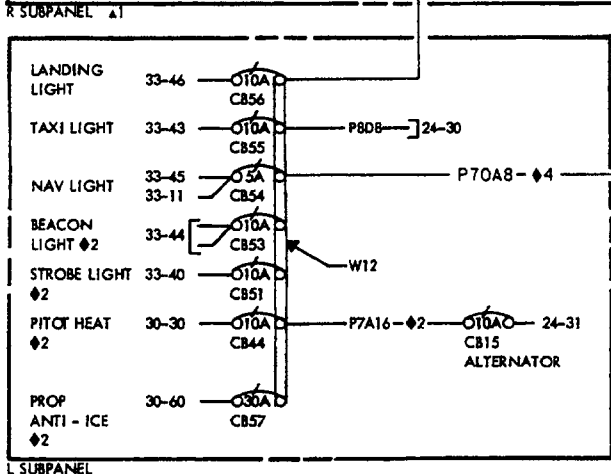
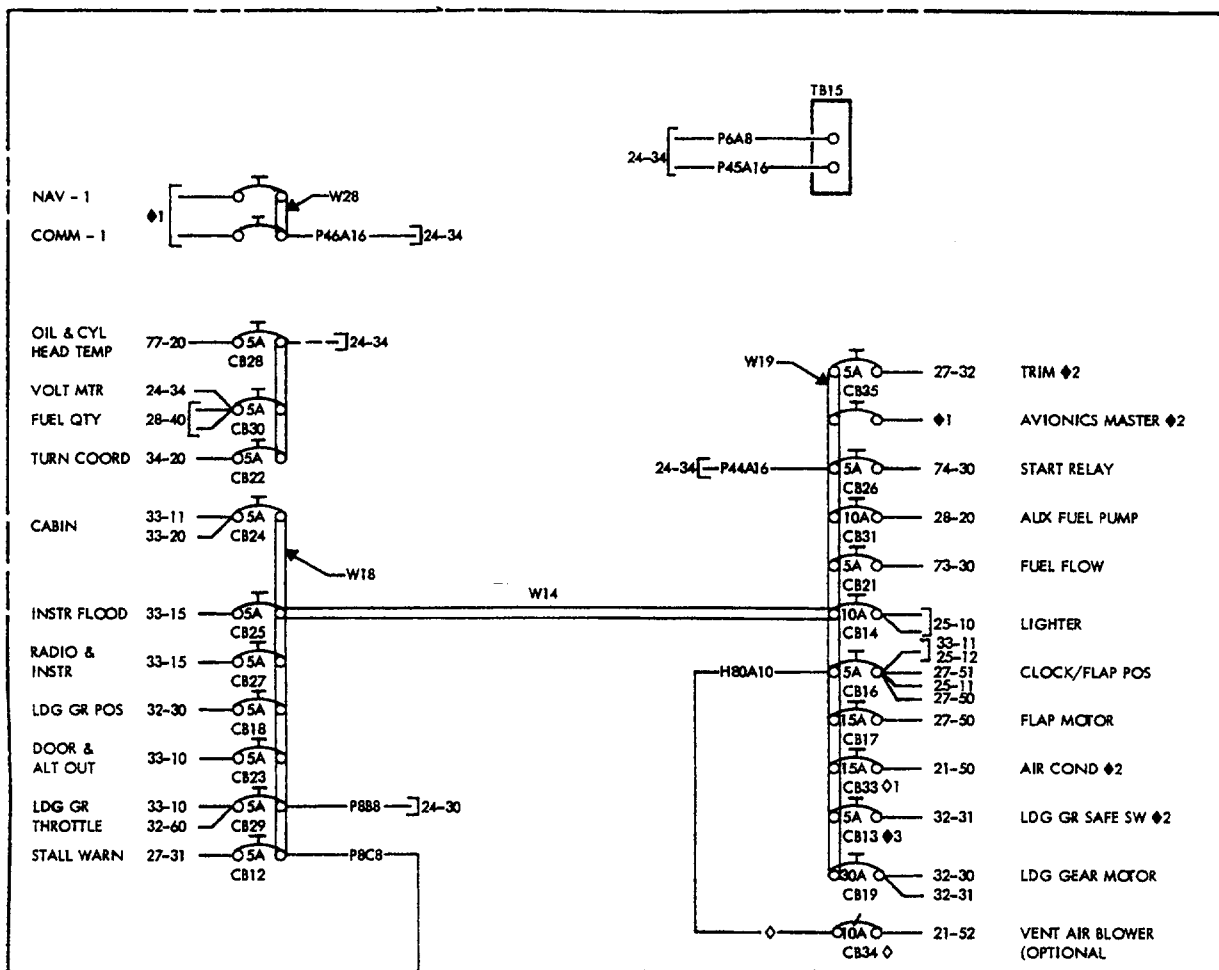

- ◆ WIRE TO BE ROUTED SEPARATELY BETWEEN BUS & CIRCUIT BREAKER.
- ◆1 REFER TO APPLICABLE AVIONICS DIAG FOR MODE OF CONNECTION.
- ◆2 OPTIONAL
- ◆3 ON ACFT E-919 ONLY.
- ◆4 WIRE & CIRCUIT BREAKER ARE USED AT EFF CE-1056 & AFTER, D-10404 & AFTER, AND CJ-156 & AFT

◇ ON ACFT E-1809 & AFT; EA-192 & AFT; CE-941 & AFT; D-10364 & AFT, ALL AS REQUIRED BY W/O.
 ◇1 CB33 NOT USED ON ACFT CJ-149 & AFT.

POWER-EMERGENCY, SINGLE NAVIGATION/COMMUNICATIONS (OPTIONAL) (Configuration 1)

Beechcraft
BONANZA
WIRING DIAGRAM MANUAL

REFERENCE DESIGNATOR	PART NUMBER	DESCRIPTION	USABLE INSTL ON ZONE CODE
		24-52-02 (Configuration 1)	
W28	114931-1-2	BUS BAR (OPTL)	240 1

EFFECTIVITY CODE

1. E-1766 THRU E-1945, E-1947 THRU E-2095; CE-919, CE-929 THRU CE-1023; CJ-156 AND AFTER; D-10348, D-10354 THRU D-10403; EA-159 THRU EA-319, EA-321 THRU EA-377
2. E-1809 THRU E-1953, E-1955 THRU E-1987; CE-941 THRU CE-989; D-10348, D-10364 THRU D-10389; EA-192 THRU EA-241, EA-243 THRU EA-272
3. E-1954, E-1988 THRU E-2095; CE-990 THRU CE-1023; D-10390 THRU D-10403; EA-242, EA-273 THRU EA-319, EA-321 THRU EA-377
4. E-1766 THRU E-1945, E-1947 THRU E-2095
5. E-1766 THRU E-1945, E-1947 THRU E-2095; CE-919, CE-929 THRU CE-1023; D-10354 THRU D-10403
6. CJ-156 AND AFTER

Beechcraft
BONANZA
WIRING DIAGRAM MANUAL

24-52-02

Configuration 2

**E-2096 THRU E-2103, E-2105 THRU E-2110; CE-1024 AND AFTER;
D-10404 AND AFTER; EA-378 THRU EA-388**

Beechcraft BONANZA WIRING DIAGRAM MANUAL

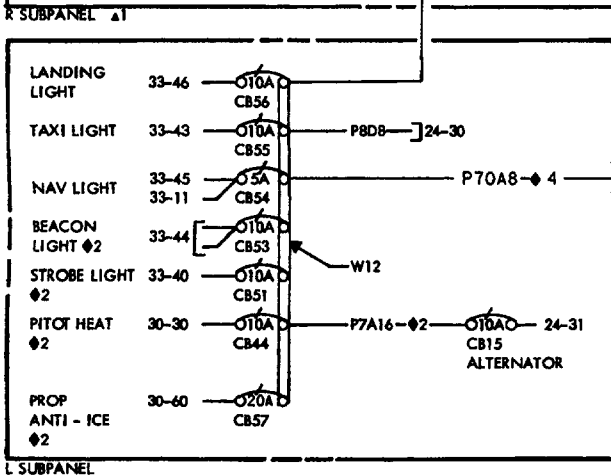
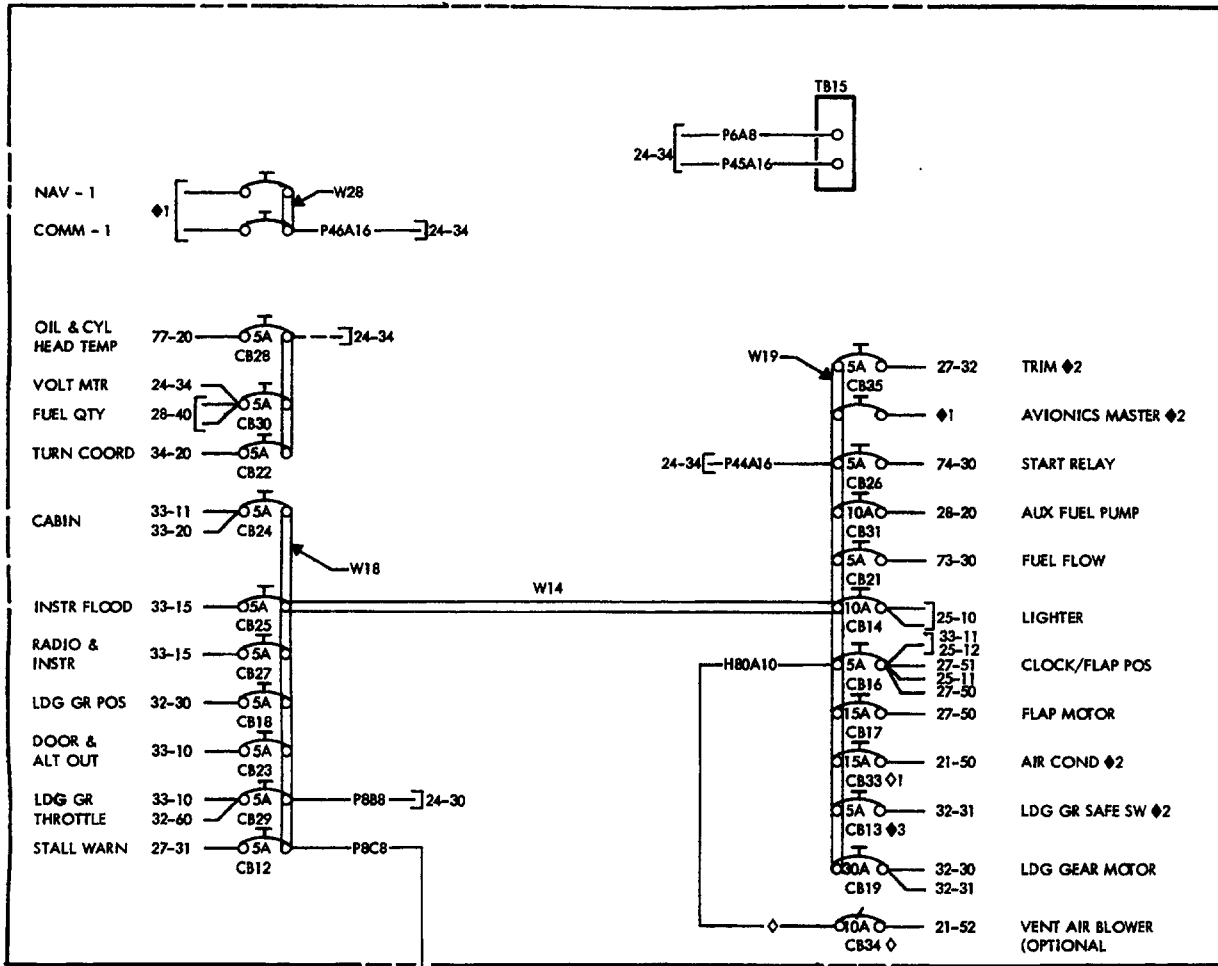

- ◆ WIRE TO BE ROUTED SEPARATELY BETWEEN BUS & CIRCUIT BREAKER.
- ◆1 REFER TO APPLICABLE AVIONICS DIAG FOR MODE OF CONNECTION.
- ◆2 OPTIONAL
- ◆3 ON ACFT E-919 ONLY.
- ◇ ON ACFT E-1809 & AFT; EA-192 & AFT; CE-941 & AFT; D-10364 & AFT, ALL AS REQUIRED BY W/O.
- ◇1 CB33 NOT USED ON ACFT CJ-149 & AFT.

- ◆4 WIRE & CIRCUIT BREAKER ARE USED AT EFF CE-1056 & AFTER AND D-10404 & AFTER

POWER-EMERGENCY, SINGLE NAVIGATION/COMMUNICATIONS (OPTIONAL) (Configuration 2)

Beechcraft
BONANZA
WIRING DIAGRAM MANUAL

REFERENCE DESIGNATOR	PART NUMBER	DESCRIPTION	USABLE	
			INSTL ZONE	ON CODE
24-52-02 (Configuration 2)				
CB12	7277-2-5	CIRCUIT BREAKER-STALL WARNING	240	1
CB13	7277-2-5	CIRCUIT BREAKER-LANDING GEAR SAFETY SWITCH (OPTL)	240	1
CB14	7277-2-10	CIRCUIT BREAKER-CIGARETTE LIGHTER	240	1
CB15	35-380132-13	CIRCUIT BREAKER-ALTERNATOR SWITCH	240	1
CB16	7277-2-5	CIRCUIT BREAKER-CLOCK/FLAP POSITION	240	1
CB17	MS24510-15	CIRCUIT BREAKER-FLAP MOTOR	240	1
CB18	7277-2-5	CIRCUIT BREAKER-LANDING GEAR POSITION	240	1
CB19	MS24510-30	CIRCUIT BREAKER-LANDING GEAR	240	1
CB21	7277-2-5	CIRCUIT BREAKER-FUEL FLOW	240	1
CB22	7277-2-5	CIRCUIT BREAKER-TURN COORDINATOR	240	1
CB23	7277-2-5	CIRCUIT BREAKER-DOOR AND ALTERNATOR OUT	240	1
CB24	7277-2-5	CIRCUIT BREAKER-CABIN AND MAP LIGHT	240	1
CB25	7277-2-5	CIRCUIT BREAKER-INSTRUMENT LIGHT	240	1
CB26	7277-2-5	CIRCUIT BREAKER-START RELAY	240	1
CB27	7277-2-5	CIRCUIT BREAKER-RADIO AND INSTRUMENT LIGHT	240	1
CB28	7277-2-5	CIRCUIT BREAKER-OIL AND CYLINDER HEAD TEMP	240	1
CB29	7277-2-5	CIRCUIT BREAKER-LANDING GEAR THROTTLE	240	1
CB30	7277-2-5	CIRCUIT BREAKER-FUEL QUANTITY INDICATOR	240	1
CB31	7277-2-10	CIRCUIT BREAKER-AUXILIARY FUEL PUMP	240	1
CB33	7271-8-15	CIRCUIT BREAKER-AIR CONDITIONER (OPTL)	240	3
CB33	435-210-104	CIRCUIT BREAKER-AIR CONDITIONER (OPTL)	240	2
CB34	35-380132-33	CIRCUIT BREAKER-VENT AIR BLOWER	240	1
CB35	7277-2-5	CIRCUIT BREAKER-TRIM (OPTL)	240	1
CB44	35-380132-3	CIRCUIT BREAKER-PITOT HEAT (OPTL)	240	1
CB51	35-380132-43	CIRCUIT BREAKER-STROBE LIGHT (OPTL)	240	1
CB53	35-380132-43	CIRCUIT BREAKER-BEACON LIGHT (OPTL)	240	1
CB54	35-380132-41	CIRCUIT BREAKER-NAVIGATION LIGHT	240	1
CB55	35-380132-43	CIRCUIT BREAKER-TAXI LIGHT	240	1
CB56	35-380132-43	CIRCUIT BREAKER-LANDING LIGHT	240	1
CB57	35-380132-9	CIRCUIT BREAKER-PROPELLER ANTI-ICE (OPTL)	240	2
CB58	35-380132-39	CIRCUIT BREAKER-STANDBY AIR PUMP	240	1
TB15	MS27212-2-2	TERMINAL BOARD (OPTL)	240	1
W12	114931-1-6	BUS LIGHT	240	1
W14	114931-1-2	BUS BAR-BUS TIE, RIGHT SUBPANEL	240	1
W18	114931-1-7	BUS BAR (OPTL)	240	1
W19	114931-1-10	BUS-SECONDARY	240	1
W28	114931-1-2	BUS BAR (OPTL)	240	1

EFFECTIVITY CODE

1. E-2096 THRU E-2103, E-2105 THRU E-2110; CE-1024 AND AFTER; D-10404 AND AFTER; EA-378 THRU EA-388
2. E-2096 THRU E-2103, E-2105 THRU E-2110
3. E-2096 THRU E-2103, E-2105 THRU E-2110; CE-1024 AND AFTER; D-10404 AND AFTER

CHAPTER

25

**EQUIPMENT/
FURNISHINGS**

Raytheon Aircraft

BEECH BONANZA WIRING DIAGRAM MANUAL

LIST OF PAGES & TABLE OF CONTENTS for CHAPTER 25 - EQUIPMENT/FURNISHINGS

SYS/SUB-SYS/ CHAP SECTION	PAGE NO.	EFFECTIVE DATE	TABLE OF CONTENTS
25-10-01	Page 1 Page 2 Page 3	Oct/95 Oct/95 Oct/95	CIGARETTE LIGHTER E-1111, E-1241 THRU E-1421, E-1423 THRU E-1550, E-1552 THRU E-1586, E-1570 THRU E-1580, E-1582 THRU E-1593; CE-748, CE-772 THRU CE-918, CE-920 THRU CE-922, CE- 924, CE-926, CE-928; CJ-149 THRU CJ155; D-10097, D- 10120 THRU D-10347, D-10349 THRU D-10352; EA-1 THRU EA-20, EA-22 THRU EA-27, EA-29 THRU EA-32
25-10-02	Page 1 Page 2 Page 3	Oct/95 Oct/95 Oct/95	CIGARETTE LIGHTER CE-919, CE-923, CE-927, CE-929 AND AFTER; CJ-156 AND AFTER; D-10348, D-10353 AND AFTER
25-10-03	Page 1 Page 2 Page 3	Oct/95 Oct/95 Oct/95	CIGARETTE LIGHTER E-1422, E1551, E1569, E-1581, E-1594 THRU E-1945, E-1947 THRU E-2103, E-2105 THRU E-2110; EA-21, EA-28, EA-33 THRU EA-319, EA-321 THRU EA-388
25-11-01	Page 1 Page 2 Page 3	Oct/95 Oct/95 01/29/99	CLOCK - PANEL E-1111, E-1241 THRU E-1719; CE-748, CE-772 THRU CE-912; D-10097, D-10120 THRU D-10349; EA-1 THRU EA- 108
25-11-02	Page 1 Page 2 Page 3	Oct/95 Oct/95 01/29/99	CLOCK - DIGITAL PANEL E-1720 THRU E-1945, E-1947 THRU E-2103, E-2105 THRU E-2110; CE-913 AND AFTER; D-10350 AND AFTER; EA-109 THRU EA-319, EA-321 THRU EA-388
25-12-01	Page 1 Page 2 Page 3	Oct/95 Oct/95 01/29/99	CLOCK - CONTROL WHEEL DIGITAL (OPTIONAL) E-1111, E-1241 THRU E-1517; CE-748, CE-772 THRU CE-861; CJ-149 ONLY; D-10097, D-10120 THRU D-10247; EA-1 THRU EA-5
25-12-02	Page 1 Page 2 Page 3	Oct/95 Oct/95 01/29/99	CLOCK - CONTROL WHEEL DIGITAL (OPTIONAL) E-1518 THRU E-1580; CE-862 THRU CE-886; D-10348, D- 10364 THRU D-10403; EA-192 THRU EA-319, EA-321 THRU EA-349
25-12-03	Page 1 Page 2 Page 3	Oct/95 Oct/95 01/29/99	CLOCK - CONTROL WHEEL DIGITAL (OPTIONAL) E-1581 THRU E-1945, E-1947 THRU E-2103, E-2105 THRU E-2110; CE-887 AND AFTER; CJ-156 AND AFTER; D-10294 AND AFTER; EA-26 THRU EA-319, EA-321 THRU EA-388
25-60-01	Page 1 Page 2 Page 3	Oct/95 Oct/95 Oct/95	TRANSMITTER-EMERGENCY LOCATOR E-1407 THRU E-1686; CE-829 THRU CE-905; CJ-150 THRU CJ-155; D-10097, D-10120 THRU D-10346; EA-3 THRU EA-80

Beechcraft
BONANZA
WIRING DIAGRAM MANUAL

25-10-01

**E-1111,E-1241 THRU E-1421,E-1423 THRU E-1550,E-1552 THRU
E-1568,E-1570 THRU E-1580,E-1582 THRU E-1593;CE-748,CE-772
THRU CE-918,CE-920 THRU CE-922,CE-924,CE-926,CE-928;CJ-149
THRU CJ-155; D-10097, D-10120 THRU D-10347,D-10349 THRU
D-10352;EA-1 THRU EA-20,EA-22 THRU EA-27,EA-29 THRU EA-32**

Beechcraft BONANZA WIRING DIAGRAM MANUAL

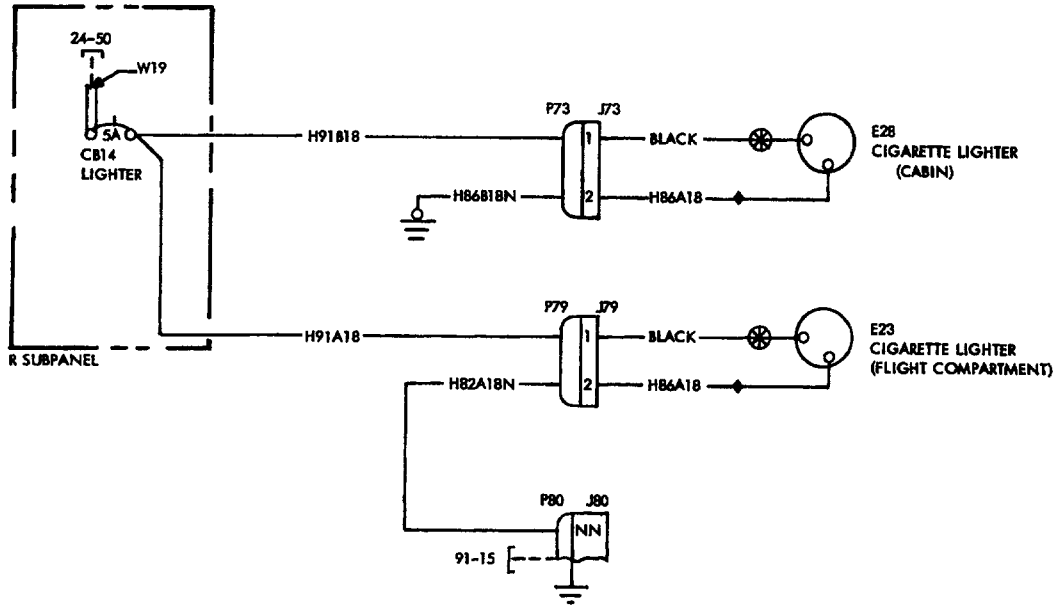

◆ WIRE NUMBER DUPLICATED FOR INTERCHANGEABILITY.

CIGARETTE LIGHTER

Beechcraft
BONANZA
WIRING DIAGRAM MANUAL

REFERENCE DESIGNATOR	PART NUMBER	DESCRIPTION	USABLE	
			INSTL ZONE	ON CODE
25-10-01				
CB14	435-205-104	CIRCUIT BREAKER-CIGARETTE LIGHTER	240	1
E23A	35-364160-5	CIGARETTE LIGHTER-CONSOLE	240	1
E23B	206352	SHELL, CLAMPING (SPARES REPLACEMENT FOR LU27049 AND 35-364160-7)	240	1
E23C	207890	BASE (SPARES REPLACEMENT FOR 206480)	240	1
E23D	207946	POP OUT UNIT (SPARES REPLACEMENT FOR 206842-24V7)	240	1
E23E	LWA29455	CORD ASSEMBLY	240	1
E23F	35-364160-3	KNOB ASSEMBLY	240	1
E28A	35-364160-5	CIGARETTE LIGHTER-CABIN	251	1
E28B	206352	SHELL, CLAMPING (SPARES REPLACEMENT FOR LU27049 AND 35-364160-7)	251	1
E28C	207890	BASE (SPARES REPLACEMENT FOR 206480)	251	1
E28D	207946	POP OUT UNIT (SPARES REPLACEMENT FOR 206842-24V7)	251	1
E28E	LWA29455	CORD ASSEMBLY	251	1
E28F	35-364160-3	KNOB ASSEMBLY	251	1
J73A	1-480319-0	RECEPTACLE HOUSING-CIGARETTE LIGHTER, CABIN	251	1
J73B	60620-1	PIN CONTACT	251	1
J73C	60618-1	PIN CONTACT	251	1
J79A	1-480319-0	RECEPTACLE HOUSING-CIGARETTE LIGHTER, CONSOLE	240	1
J79B	60620-1	PIN CONTACT	240	1
J79C	60618-1	PIN CONTACT	240	1
J80	204814-1	RECEPTACLE-GROUNDING BLOCK	231	1
P73A	1-480318-0	PLUG-CIGARETTE LIGHTER, CABIN	251	1
P73B	60617-1	SOCKET CONTACT	251	1
P79A	1-480318-0	PLUG-CIGARETTE LIGHTER, CONSOLE	240	1
P79B	60617-1	SOCKET CONTACT	240	1
P80A	200838-3	PLUG-GROUNDING BLOCK	231	1
P80B	201224-1	STRAIN RELIEF	231	1
P80C	201328-1	SOCKET CONTACT	231	1
P80D	200333-1	SOCKET CONTACT	231	1
P80E	203618-1	JACKSCREW	231	1

EFFECTIVITY CODE

1. E-1111,E-1241 THRU E-1421,E-1423 THRU E-1550,E-1552 THRU E-1568,E-1570 THRU E-1580,E-1582 THRU E-1593;CE-748,CE-772 THRU CE-918,CE-920 THRU CE-922,CE-924,CE-926,CE-928;CJ-149 THRU CJ-155; D-10097, D-10120 THRU D-10347,D-10349 THRU D-10352;EA-1 THRU EA-20,EA-22 THRU EA-27,EA-29 THRU EA-32

Beechcraft
BONANZA
WIRING DIAGRAM MANUAL

25-10-02

**CE-919, CE-923, CE-925, CE-927, CE-929 AND AFTER; CJ-156 AND
AFTER; D-10348, D-10353 AND AFTER**

Beechcraft BONANZA WIRING DIAGRAM MANUAL

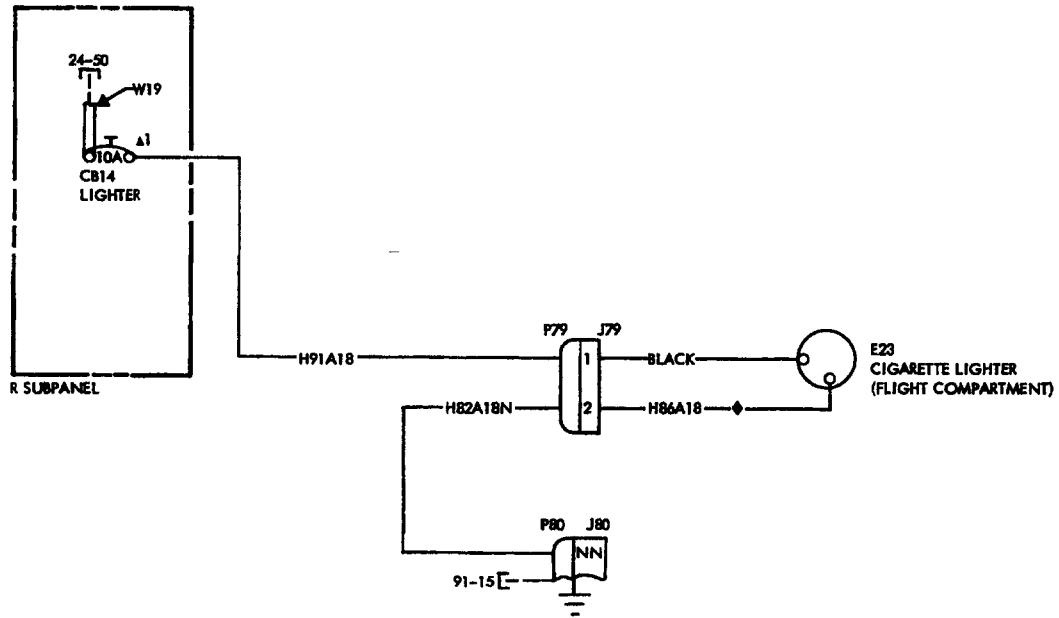

◆ WIRE NUMBER
DUPLICATED FOR
INTERCHANGEABILITY.

CIGARETTE LIGHTER

Beechcraft
BONANZA
WIRING DIAGRAM MANUAL

REFERENCE DESIGNATOR	PART NUMBER	DESCRIPTION	USABLE	
			INSTL ZONE	ON CODE
25-10-02				
CB14	435-205-104	CIRCUIT BREAKER-CIGARETTE LIGHTER	240	2
CB14	7277-2-5	CIRCUIT BREAKER-CIGARETTE LIGHTER	240	3
E23A	35-364160-5	CIGARETTE LIGHTER-CONSOLE	240	1
E23B	206352	SHELL, CLAMPING (SPARES REPLACEMENT FOR LU27049 AND 35-364160-7)	240	1
E23C	207890	BASE (SPARES REPLACEMENT FOR 206480)	240	1
E23D	207946	POP OUT UNIT (SPARES REPLACEMENT FOR 206842-24V7)	240	1
E23E	LWA29455	CORD ASSEMBLY	240	1
E23F	35-364160-3	KNOB ASSEMBLY	240	1
J79A	1-480319-0	RECEPTACLE HOUSING-CIGARETTE LIGHTER, CONSOLE	240	1
J79B	60620-1	PIN CONTACT	240	1
J79C	60618-1	PIN CONTACT	240	1
J80	204814-1	RECEPTACLE-GROUNDING BLOCK	231	1
P79A	1-480318-0	PLUG-CIGARETTE LIGHTER, CONSOLE	240	1
P79B	60617-1	SOCKET CONTACT	240	1
P80A	200838-3	PLUG-GROUNDING BLOCK	231	1
P80B	201224-1	STRAIN RELIEF	231	1
P80C	201328-1	SOCKET CONTACT	231	1
P80D	200333-1	SOCKET CONTACT	231	1
P80E	203618-1	JACKSCREW	231	1

EFFECTIVITY CODE

1. CE-919, CE-923, CE-925, CE-927, CE-929 AND AFTER; CJ-156 AND AFTER; D-10348, D-10353 AND AFTER
2. D-10353 ONLY
3. CE-919, CE-929 AND AFTER; CJ-156 AND AFTER; D-10348, D-10354 AND AFTER

Beechcraft
BONANZA
WIRING DIAGRAM MANUAL

25-10-03

**E-1422, E-1551, E-1569, E-1581, E-1594 THRU E-1945, E-1947 THRU
E-2103, E-2105 THRU E-2110; EA-21, EA-28, EA-33 THRU EA-319,
EA-321 THRU EA-388**

Beechcraft BONANZA WIRING DIAGRAM MANUAL

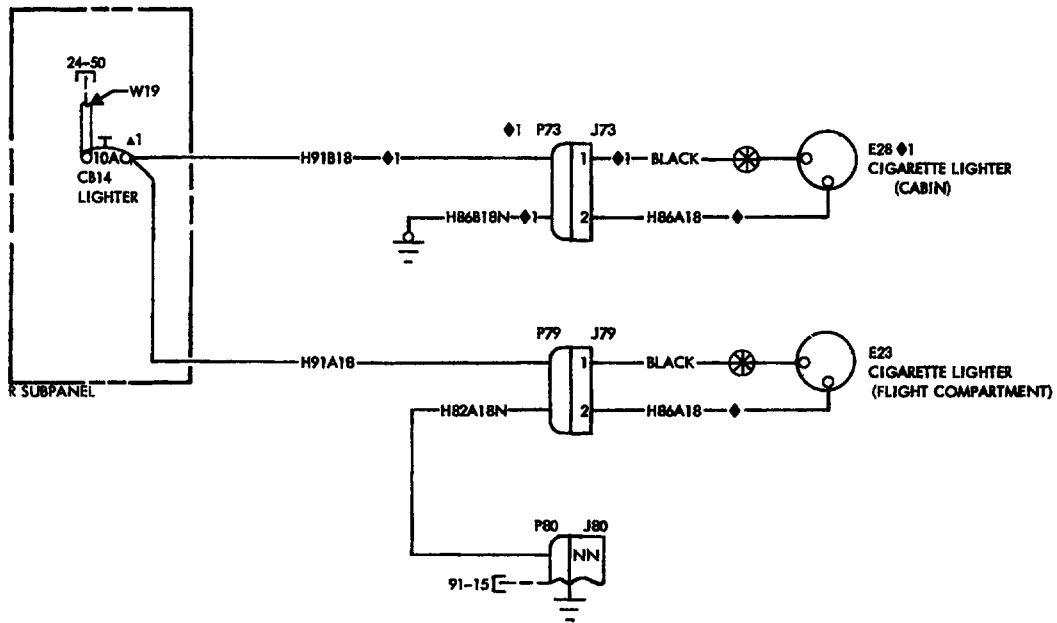

◆1 OPTIONAL EQUIPMENT & WIRING

◆ WIRE NUMBER DUPLICATED FOR INTERCHANGEABILITY.

CIGARETTE LIGHTER

Deechcraft
BONANZA
WIRING DIAGRAM MANUAL

REFERENCE DESIGNATOR	PART NUMBER	DESCRIPTION	USABLE	
			INSTL	ON ZONE CODE
25-10-03				
CB14	435-205-104	CIRCUIT BREAKER-CIGARETTE LIGHTER	240	2
CB14	7277-2-5	CIRCUIT BREAKER-CIGARETTE LIGHTER	240	3
E23A	35-364160-5	CIGARETTE LIGHTER-CONSOLE	240	1
E23B	206352	SHELL, CLAMPING (SPARES REPLACEMENT FOR LU27049 AND 35-364160-7)	240	1
E23C	207890	BASE (SPARES REPLACEMENT FOR 206480)	240	1
E23D	207946	POP OUT UNIT (SPARES REPLACEMENT FOR 206842-24V7)	240	1
E23E	LWA29455	CORD ASSEMBLY	240	1
E23F	35-364160-3	KNOB ASSEMBLY	240	1
E28A	35-364160-9	CIGARETTE LIGHTER-CABIN	251	1
E28B	206352	SHELL, CLAMPING (SPARES REPLACEMENT FOR LU27049 AND 35-364160-7)	251	1
E28C	207890	BASE (SPARES REPLACEMENT FOR 206480)	251	1
E28D	207946	POP OUT UNIT (SPARES REPLACEMENT FOR 206842-24V7)	251	1
E28E	LWA29455	CORD ASSEMBLY	251	1
E28F	35-364160-3	KNOB ASSEMBLY	251	1
J73A	1-480319-0	RECEPTACLE HOUSING-CIGARETTE LIGHTER, CABIN	251	1
J73B	60620-1	PIN CONTACT	251	1
J73C	60618-1	PIN CONTACT	251	1
J79A	1-480319-0	RECEPTACLE HOUSING-CIGARETTE LIGHTER, CONSOLE	240	1
J79B	60620-1	PIN CONTACT	240	1
J79C	60618-1	PIN CONTACT	240	1
J80	204814-1	RECEPTACLE-GROUNDING BLOCK	231	1
P73A	1-480318-0	PLUG-CIGARETTE LIGHTER, CABIN (OPTL)	251	1
P73B	60617-1	SOCKET CONTACT (OPTL)	251	1
P79A	1-480318-0	PLUG-CIGARETTE LIGHTER, CONSOLE	240	1
P79B	60617-1	SOCKET CONTACT	240	1
P80A	200838-3	PLUG-GROUNDING BLOCK	231	1
P80B	201224-1	STRAIN RELIEF	231	1
P80C	201328-1	SOCKET CONTACT	231	1
P80D	200333-1	SOCKET CONTACT	231	1
P80E	203618-1	JACKSCREW	231	1

EFFECTIVITY CODE

1. E-1422, E 1551, E-1569, E-1581, E-1594 AND AFTER; EA-21, EA-28, EA-33 THRU EA-319, EA-321 THRU EA-388
2. E-1422, E-1551, E-1569, E-1581, E-1594 THRU E-1765; EA-21, EA-28, EA-33 THRU EA-158
3. E-1766 THRU E-1945, E-1947 THRU E-2103, E-2105 THRU E-2110; EA-159 THRU EA-319, EA-321 THRU EA-388

Beechcraft
BONANZA
WIRING DIAGRAM MANUAL

25-11-01

**E-1111, E-1241 THRU E-1719; CE-748, CE-772 THRU CE-912; D-10097,
D-10120 THRU D-10349; EA-1 THRU EA-108**

Beechcraft BONANZA WIRING DIAGRAM MANUAL

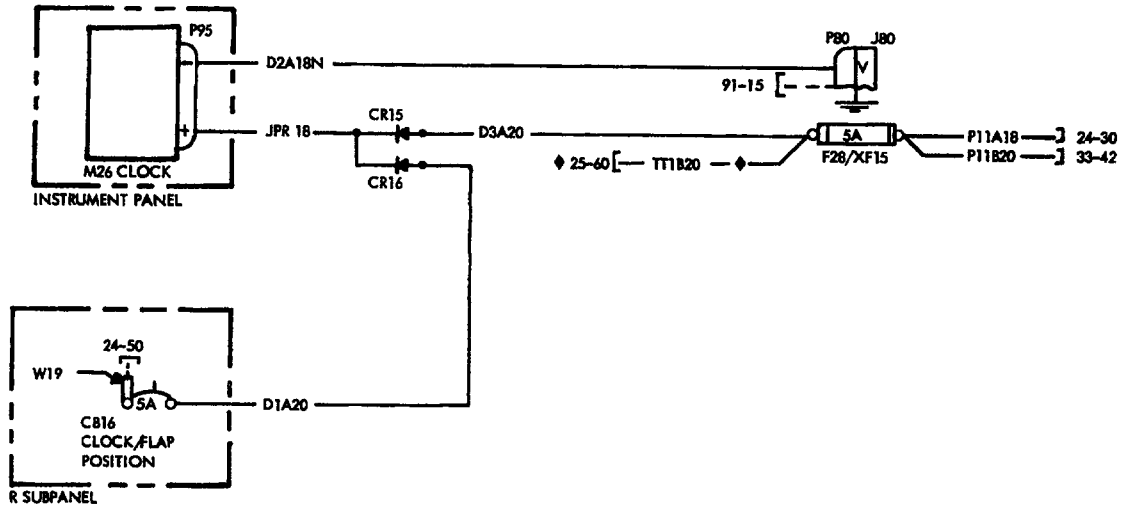

◆ ON ACFT E-1407 THRU E-1686; EA-3 THRU EA-80; CE-829 THRU CE-905; CJ-150 THRU CJ-155; D-10097, D-10120 THRU D-10346.

CLOCK, PANEL

Raytheon Aircraft

BEECH BONANZA WIRING DIAGRAM MANUAL

REFERENCE DESIGNATOR	PART NUMBER	DESCRIPTION	USABLE	
			INSTL ZONE	ON CODE
25-11-01				
CB16	435-205-104	CIRCUIT BREAKER-CLOCK	240	3
CB16	7277-2-5	CIRCUIT BREAKER-CLOCK	240	2
CR15	1N4007	DIODE-CLOCK (SUPERSEDED BY 132408-22)	240	1
CR15	132408-22	DIODE-CLOCK (SUPERSEDES 1N4007)	240	1
CR16	1N4007	DIODE-CLOCK (SUPERSEDED BY 132408-22)	240	1
CR16	132408-22	DIODE-CLOCK (SUPERSEDES 1N4007)	240	1
F28	AGC5	FUSE-CLOCK	222	1
J80	204814-1	RECEPTACLE-GROUNDING BLOCK	231	1
M26	58-380077-3	CLOCK-PANEL	240	1
P80A	200838-3	PLUG-GROUNDING BLOCK	231	1
P80B	201224-1	STRAIN RELIEF	231	1
P80C	201328-1	SOCKET CONTACT	231	1
P80D	200333-1	SOCKET CONTACT	231	1
P80E	203618-1	JACKSCREW	231	1
P95A	2965981	PLUG-PANEL CLOCK	240	1
P95B	2962508	TERMINAL	251	1
XF15	4532	FUSEHOLDER-AMMETER/CLOCK	222	1

CODES OF EFFECTIVITY

1. E-1111, E-1241 THRU E-1719; CE-748, CE-772 THRU CE-912; D-10097, D-10120 THRU D-10349; EA-1 THRU EA-108
2. D-10348 ONLY
3. E-1111, E-1241 THRU E-1719; CE-748, CE-772 THRU CE-912; D-10097, D-10120 THRU D-10347, D-10349; EA-1 THRU EA-108

Beechcraft
BONANZA
WIRING DIAGRAM MANUAL

25-11-02

**E-1720 THRU E-1945, E-1947 THRU E-2103, E-2105 THRU E-2110;
CE-913 AND AFTER; D-10350 AND AFTER; EA-109 THRU EA-319,
EA-321 THRU EA-388**

Beechcraft BONANZA WIRING DIAGRAM MANUAL

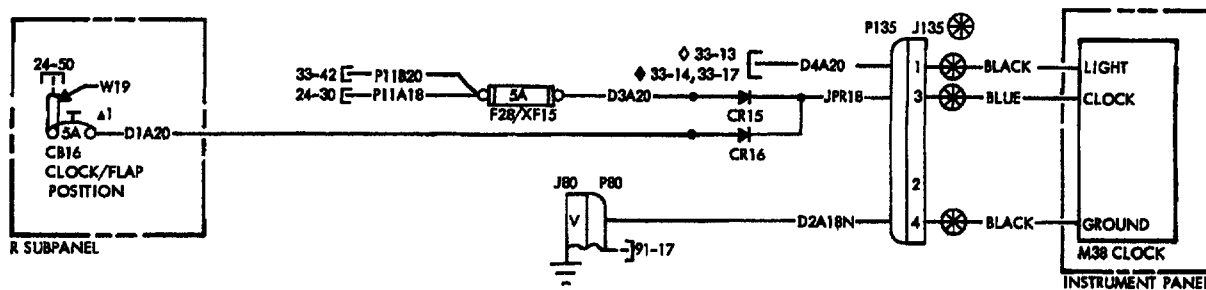

- ◇ ON ACFT W/O OPTIONAL WEDGE LIGHTS OR POST LIGHTS.
- ◆ ON ACFT WITH OPTIONAL WEDGE LIGHTS REF 33-14. ON ACFT WITH OPTIONAL POST LIGHTS REF 33-17.

CLOCK, DIGITAL PANEL

Raytheon Aircraft

BEECH BONANZA WIRING DIAGRAM MANUAL

REFERENCE DESIGNATOR	PART NUMBER	DESCRIPTION	INSTL ZONE	USABLE ON CODE
25-11-02				
CB16	435-205-104	CIRCUIT BREAKER-CLOCK	240	2
CB16	7277-2-5	CIRCUIT BREAKER-CLOCK	240	3
CR15	1N4007	DIODE-CLOCK (SUPERSEDED BY 132408-22)	240	1
CR15	132408-22	DIODE-CLOCK (SUPERSEDES 1N4007)	240	1
CR16	1N4007	DIODE-CLOCK (SUPERSEDED BY 132408-22)	240	1
CR16	132408-22	DIODE-CLOCK (SUPERSEDES 1N4007)	240	1
F28	AGC5	FUSE-CLOCK	222	1
J80	204814-1	RECEPTACLE-GROUNDING BLOCK	231	1
M38	AT422002	CLOCK-PANEL, DIGITAL (SPARES REPLACEMENT FOR AT422001)	240	1
P135A	1-480424-0	PLUG-PANEL CLOCK	240	1
P135B	60617-5	SOCKET CONTACT	240	1
P80A	200838-3	PLUG-GROUNDING BLOCK	231	1
P80B	201224-1	STRAIN RELIEF	231	1
P80C	201328-1	SOCKET CONTACT	231	1
P80D	200333-1	SOCKET CONTACT	231	1
P80E	203618-1	JACKSCREW	231	1
XF15	4532	FUSEHOLDER-AMMETER/CLOCK	222	1

CODES OF EFFECTIVITY

1. E-1720 THRU E-1945, E-1947 THRU E-2103, E-2105 THRU E-2110; CE-913 AND AFTER; D-10350 AND AFTER; EA-109 THRU EA-319, EA-321 THRU EA-388
2. E-1720 THRU E-1765; CE-913 THRU CE-918, CE-920 THRU CE-928; D-10350 THRU D-10353; EA-109 THRU EA-158
3. E-1766 THRU E-1945, E-1947 THRU E-2103, E-2105 THRU E-2110; CE-919, CE-929 AND AFTER; D-10354 AND AFTER; EA-159 THRU EA-319, EA-321 THRU EA-388

Beechcraft
BONANZA
WIRING DIAGRAM MANUAL

25-12-01

**E-1111, E-1241 THRU E-1517; CE-748, CE-772 THRU CE-861; CJ-149
ONLY; D-10097, D-10120 THRU D-10247; EA-1 THRU EA-5**

Raytheon Aircraft

BEECH BONANZA WIRING DIAGRAM MANUAL

REFERENCE DESIGNATOR	PART NUMBER	DESCRIPTION	INSTL ZONE	USABLE ON CODE
25-12-01				
CB16	435-205-104	CIRCUIT BREAKER-CLOCK	240	1
CR15	1N4007	DIODE-CLOCK (SUPERSEDED BY 132408-22)	240	1
CR15	132408-22	DIODE-CLOCK (SUPERSEDES 1N4007)	240	1
CR16	1N4007	DIODE-CLOCK (SUPERSEDED BY 132408-22)	240	1
CR16	132408-22	DIODE-CLOCK (SUPERSEDES 1N4007)	240	1
F28	AGC5	FUSE-CLOCK	222	1
J80	204814-1	RECEPTACLE-GROUNDING BLOCK	231	1
M27	CT2A	CLOCK-DIGITAL CONTROL WHEEL (OPTL)	252	1
P80A	200838-3	PLUG-GROUNDING BLOCK	231	1
P80B	201224-1	STRAIN RELIEF	231	1
P80C	201328-1	SOCKET CONTACT	231	1
P80D	200333-1	SOCKET CONTACT	231	1
P80E	203618-1	JACKSCREW	231	1
W19	114931-1-10	BUS-SECONDARY	240	1
W30	101-384082-3	COILED CORD	240	1
XF15	4532	FUSEHOLDER-AMMETER/CLOCK	222	1

CODES OF EFFECTIVITY

1. E-1111, E-1241 THRU E-1517; CE-748, CE-772 THRU CE-861; CJ-149 ONLY; D-10097, D-10120 THRU D-10247; EA-1 THRU EA-5

Beechcraft
BONANZA
WIRING DIAGRAM MANUAL

25-12-02

**E-1518 THRU E-1580; CE-862 THRU CE-886; CJ-150 THRU CJ-155;
D-10248 THRU D-10293; EA-6 THRU EA-25**

Raytheon Aircraft

BEECH BONANZA WIRING DIAGRAM MANUAL

REFERENCE DESIGNATOR	PART NUMBER	DESCRIPTION	INSTL ZONE	USABLE ON CODE
25-12-02				
CB16	435-205-104	CIRCUIT BREAKER-CLOCK	240	1
CR15	1N4007	DIODE-CLOCK (SUPERSEDED BY 132408-22)	240	1
CR15	132408-22	DIODE-CLOCK (SUPERSEDES 1N4007)	240	1
CR16	1N4007	DIODE-CLOCK (SUPERSEDED BY 132408-22)	240	1
CR16	132408-22	DIODE-CLOCK (SUPERSEDES 1N4007)	240	1
F28	AGC5	FUSE-CLOCK	222	1
J80	204814-1	RECEPTACLE-GROUNDING BLOCK	231	1
M39	AT4220A4	CLOCK-CONTROL WHEEL DIGITAL (OPTL)	240	1
P80A	200838-3	PLUG-GROUNDING BLOCK	231	1
P80B	201224-1	STRAIN RELIEF	231	1
P80C	201328-1	SOCKET CONTACT	231	1
P80D	200333-1	SOCKET CONTACT	231	1
P80E	203618-1	JACKSCREW	231	1
W19	114931-1-10	BUS-SECONDARY	240	1
W30	101-384082-3	COILED CORD	240	1
XF15	4532	FUSEHOLDER-AMMETER/CLOCK	222	1

CODES OF EFFECTIVITY

1. E-1518 THRU E-1580; CE-862 THRU CE-886; CJ-150 THRU CE-155; D-10248 THRU D-10293; EA-6 THRU EA-25

Beechcraft
BONANZA
WIRING DIAGRAM MANUAL

25-12-03

**E-1581 THRU E-1945, E-1947 THRU E-2103, E-2105 THRU E-2110;
CE-887 AND AFTER; CJ-156 AND AFTER; D-10294 AND AFTER;
EA-26 THRU EA-319, EA-321 THRU EA-388**

Beechcraft BONANZA WIRING DIAGRAM MANUAL

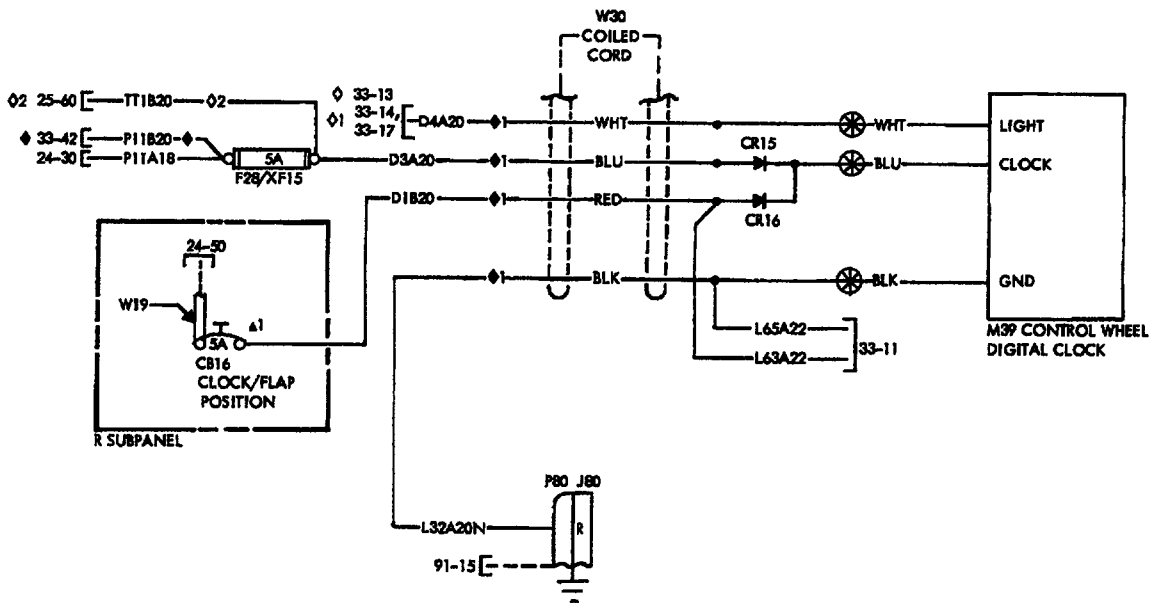

- ◇ ON ACFT W/O OPTIONAL WEDGE LIGHTS OR POST LIGHTS.
- ◇1 ON ACFT WITH OPTIONAL WEDGE LIGHTS REF 33-14.
ON ACFT WITH OPTIONAL POST LIGHTS REF 33-17.
- ◇2 WIRE NOT USED E-1687 & AFT;
EA-81 & AFT; CE-906 & AFT;
CJ-156 & AFT; D-10347 & AFT.
- ◇ ON ACFT HAVING OPTIONAL COURTESY LIGHT INSTALLATION.
- ◇1 FOR MODE OF CONNECTION TO COILED CORD, REFER TO APPLICABLE AVIONICS DWG.

CLOCK, CONTROL WHEEL DIGITAL (OPTIONAL)

Raytheon Aircraft

BEECH BONANZA WIRING DIAGRAM MANUAL

REFERENCE DESIGNATOR	PART NUMBER	DESCRIPTION	INSTL ZONE	USABLE ON CODE
25-12-03				
CB16	435-205-104	CIRCUIT BREAKER-CLOCK	240	2
CB16	7277-2-5	CIRCUIT BREAKER-CLOCK	240	3
CR15	1N4007	DIODE-CLOCK (SUPERSEDED BY 132408-22)	240	1
CR15	132408-22	DIODE-CLOCK (SUPERSEDES 1N4007)	240	1
CR16	1N4007	DIODE-CLOCK (SUPERSEDED BY 132408-22)	240	1
CR16	132408-22	DIODE-CLOCK (SUPERSEDES 1N4007)	240	1
F28	AGC5	FUSE-CLOCK	222	1
J80	204814-1	RECEPTACLE-GROUNDING BLOCK	231	1
M39	AT4220A6	CLOCK-CONTROL WHEEL, DIGITAL	252	1
P80A	200838-3	PLUG-GROUNDING BLOCK	231	1
P80B	201224-1	STRAIN RELIEF	231	1
P80C	201328-1	SOCKET CONTACT	231	1
P80D	200333-1	SOCKET CONTACT	231	1
P80E	203618-1	JACKSCREW	231	1
W19	114931-1-10	BUS-SECONDARY	240	1
W30	101-384082-3	COILED CORD	240	1
XF15	4532	FUSEHOLDER-AMMETER/CLOCK	222	1

CODES OF EFFECTIVITY

1. E-1581 THRU E-1945, E-1947 THRU E-2103, E-2105 THRU E-2110; CE-887 AND AFTER; CJ-156 AND AFTER; D-10294 AND AFTER; EA-26 THRU EA-319, EA-321 THRU EA-388
2. E-1581 THRU E-1765; CE-887 THRU E-918, CE-920 THRU CE-928; D-10294 THRU D-10347, D-10349 THRU D-10353; EA-26 THRU EA-158
3. E-1766 THRU E-1945, E-1947 THRU E-2103, E-2105 THRU E-2110; CE-919, CE-929 AND AFTER; CJ-156 AND AFTER; D-10348, D-10354 AND AFTER; EA-159 THRU EA-319, EA-321 THRU EA-388

Beechcraft
BONANZA
WIRING DIAGRAM MANUAL

25-60-01

**E-1407 THRU E-1686; CE-829 THRU CE-905; CJ-150 THRU CJ-155;
D-10097, D-10120 THRU D-10346; EA-3 THRU EA-80**

Beechcraft BONANZA WIRING DIAGRAM MANUAL

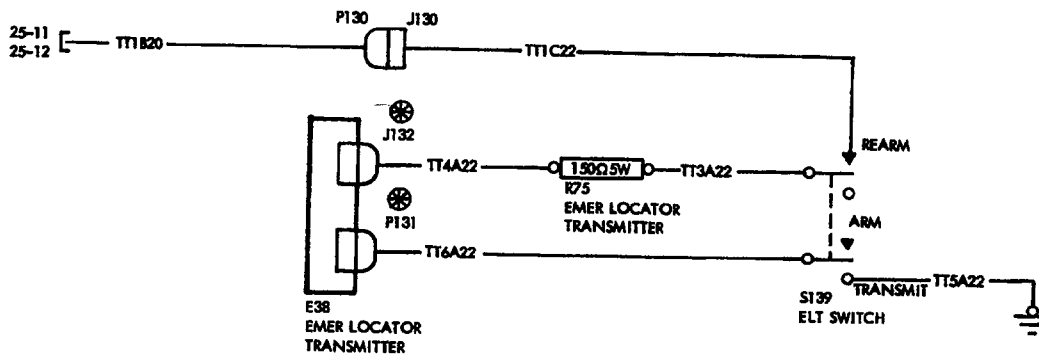

TRANSMITTER-EMERGENCY LOCATOR

Beechcraft
BONANZA
WIRING DIAGRAM MANUAL

REFERENCE DESIGNATOR	PART NUMBER	DESCRIPTION	USABLE	
			INSTL	ON ZONE CODE
25-60-01				
E38	TR70-13	TRANSMITTER-EMERGENCY LOCATOR	310	1
J130A	1-350868-0	RECEPTACLE HOUSING-ELT SWITCH	310	1
J130B	350690-1	PIN CONTACT	310	1
J132	03-06-1011	CONNECTOR-EMERGENCY LOCATOR TRANSMITTER	310	1
P130A	1-350867-0	PLUG HOUSING-ELT SWITCH	310	1
P130B	350689-1	SOCKET CONTACT	310	1
P131	03-06-2011	SOCKET HOUSING-EMERGENCY LOCATOR TRANSMITTER	310	1
R75	RH5-150	RESISTOR	310	1
S139	MST205T	SWITCH-EMERGENCY LOCATOR TRANSMITTER	310	1

EFFECTIVITY CODE

1. E-1407 THRU E-1686; CE-829 THRU CE-905; CJ-150 THRU CJ-155; D-10097, D-10120 THRU D-10346; EA-3 THRU EA-80

CHAPTER

27

**FLIGHT
CONTROLS**

Beechcraft
BONANZA
WIRING DIAGRAM MANUAL
LIST OF PAGES & TABLE OF CONTENTS
for
CHAPTER 27 - FLIGHT CONTROLS

SYS/SUB-SYS/ CHAP SECTION	PAGE NO.	EFFECTIVE DATE	TABLE OF CONTENTS
27-31-01	Page 1	OCT/95	STALL WARNING
	Page 2	OCT/95	
	Page 3	OCT/95	
27-31-02 (Config 1)	Page 1	OCT/95	STALL WARNING
	Page 2	OCT/95	
	Page 3	OCT/95	
27-31-02 (Config 2)	Page 1	OCT/95	STALL WARNING
	Page 2	OCT/95	
	Page 3	OCT/95	
27-32-01	Page 1	OCT/95	ELEVATOR TRIM (OPTIONAL)
	Page 2	OCT/95	
	Page 3	OCT/95	
27-50-01	Page 1	OCT/95	FLAPS-MOTOR
	Page 2	OCT/95	
	Page 3	OCT/95	
27-50-02 (Config 1)	Page 1	OCT/95	FLAPS-MOTOR
	Page 2	OCT/95	
	Page 3	OCT/95	
27-50-02 (Config 2)	Page 1	OCT/95	FLAPS-MOTOR
	Page 2	OCT/95	
	Page 3	OCT/95	
27-51-01	Page 1	OCT/95	FLAPS-POSITION INDICATOR
	Page 2	OCT/95	
	Page 3	OCT/95	
27-51-02	Page 1	OCT/95	FLAPS-POSITION INDICATOR
	Page 2	OCT/95	
	Page 3	OCT/95	

Beechcraft
BONANZA
WIRING DIAGRAM MANUAL

27-31-01

**E-1111, E-1241 THRU E-1370; CE-748, CE-772 THRU CE-815; CJ-149
ONLY; D-10097, D-10120 THRU D-10178**

Beechcraft BONANZA WIRING DIAGRAM MANUAL

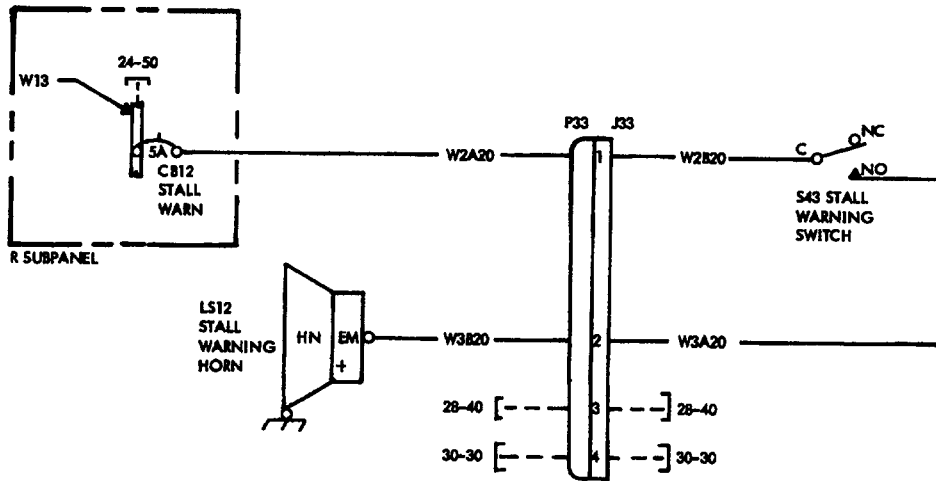

STALL WARNING

Beechcraft
BONANZA
WIRING DIAGRAM MANUAL

REFERENCE DESIGNATOR	PART NUMBER	DESCRIPTION	USABLE	
			INSTL ZONE	ON CODE
27-31-01				
CB12	435-205-104	CIRCUIT BREAKER-STALL WARNING	240	1
J33A	206153-1	RECEPTACLE-STALL WARNING HORN	532	1
J33B	66103-2	SOCKET CONTACT	532	1
J33C	66099-2	SOCKET CONTACT	532	1
J33D	206062-1	STRAIN RELIEF	532	1
LS12	169-380021-11	HORN-STALL WARNING	231	1
P33A	206060-1	PLUG-STALL WARNING HORN	532	1
P33B	206062-1	STRAIN RELIEF	532	1
P33C	66101-2	SOCKET CONTACT	532	1
P33D	66105-2	SOCKET CONTACT	532	1
S43	151-10	SWITCH-STALL WARNING	531	1
W13	114931-1-12	BUS-MAIN	240	1

EFFECTIVITY CODE

1. E-1111, E-1241 THRU E-1370; CE-748, CE-772 THRU CE-815; CJ-149 ONLY; D-10097, D-10120 THRU D-10178

Beechcraft
BONANZA
WIRING DIAGRAM MANUAL

27-31-02

Configuration 1

**E-1371 THRU E-1945, E-1947 THRU E-2103, E-2105 THRU E-2110;
CE-816 THRU CE-1300, CE-1302 THRU CE-1306; CJ-150 THRU CJ-179;
D-10179 AND AFTER; EA-1 THRU EA-319, EA-321 THRU EA-388**

Beechcraft BONANZA WIRING DIAGRAM MANUAL

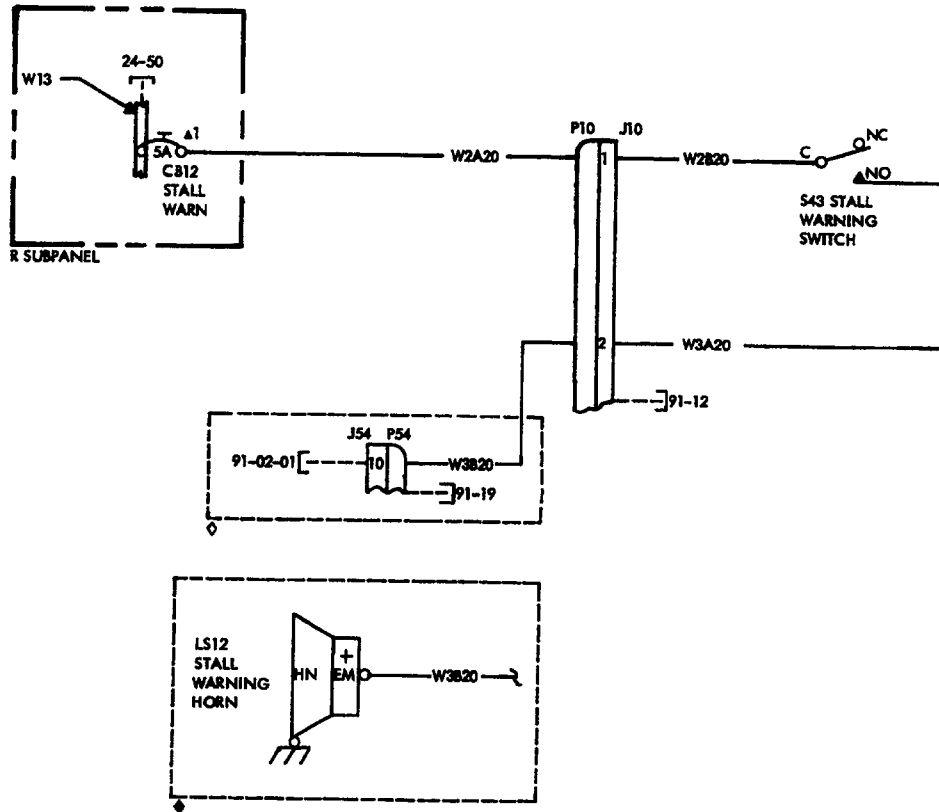

◇ WIRE ROUTING ON ACFT E-1766 & AFT; EA-159 & AFT;
CE-919, CE-923, CE-925, CE-927, CE-929 & AFT; CJ-156
& AFT; D-10354 & AFTER.

◆ WIRE ROUTING ON ACFT
E-1371 THRU E-1765, EA-1
THRU EA-158; CE-816
THRU CE-918, CE-920
THRU CE-922, CE-924,
CE-926 & CE-928; D-10179
THRU D-10353, CJ-150
THRU CJ-155.

**STALL WARNING
(Configuration 1)**

Beechcraft
BONANZA
WIRING DIAGRAM MANUAL

REFERENCE DESIGNATOR	PART NUMBER	DESCRIPTION	USABLE	
			INSTL	ON ZONE CODE
27-31-02 (Configuration 1)				
CB12	435-205-104	CIRCUIT BREAKER-STALL WARNING	240	2
CB12	7277-2-5	CIRCUIT BREAKER-STALL WARNING	240	3
J10A	206036-3	RECEPTACLE-LEFT WHEELWELL ACCESS	532	1
J10B	206070-1	STRAIN RELIEF	532	1
J10C	66103-2	PIN CONTACT	532	1
J10D	66099-2	PIN CONTACT	532	1
J54A	206151-2	RECEPTACLE-JUNCTION BOX ASSEMBLY	231	1
J54B	206138-1	STRAIN RELIEF CLAMP	231	1
J54C	66103-2	PIN CONTACT	231	1
LS12	169-380021-11	HORN-STALL WARNING	231	4
P10A	206037-1	PLUG-LEFT WHEELWELL ACCESS	532	1
P10B	66101-2	SOCKET CONTACT	532	1
P10C	66105-2	SOCKET CONTACT	532	1
P10D	206070-1	STRAIN RELIEF CLAMP	532	1
P54A	206150-1	PLUG-JUNCTION BOX ASSEMBLY	231	1
P54B	206138-1	STRAIN RELIEF	231	1
P54C	66105-2	SOCKET CONTACT	231	1
S43	151-10	SWITCH-STALL WARNING	531	1
W13	114931-1-12	BUS-MAIN	240	1

EFFECTIVITY CODE

1. E-1371 THRU E-1945, E-1947 THRU E-2103, E-2105 THRU E-2110; CE-816 THRU CE-1300, CE-1302 THRU CE-1306; CJ-150 THRU CJ-179; D-10179 AND AFTER; EA-1 THRU EA-319, EA-321 THRU EA-388
2. E-1371 THRU E-1765; CE-816 THRU CE-918, CE-920 THRU CE-928; CJ-150 THRU CJ-155; D-10179 THRU D-10347, D-10349 THRU D-10353; EA-1 THRU EA-158
3. E-1766 THRU E-1945, E-1947 THRU E-2103, E-2105 THRU E-2110; CE-919, CE-929 THRU CE-1300, CE-1302 THRU CE-1306; CJ-156 THRU CJ-179; D-10348, D-10354 AND AFTER; EA-159 THRU EA-319, EA-321 THRU EA-388
4. E-1371 THRU E-1765; CE-816 THRU CE-918, CE-920 THRU CE-922, CE-924, CE-926, CE-928; CJ-150 THRU CJ-155; D-10179 THRU D-10353; EA-1 THRU EA-158

Beechcraft
BONANZA
WIRING DIAGRAM MANUAL

27-31-02

Configuration 2

CE-1301, CE-1307 AND AFTER; CJ-180 AND AFTER

Beechcraft
BONANZA
WIRING DIAGRAM MANUAL

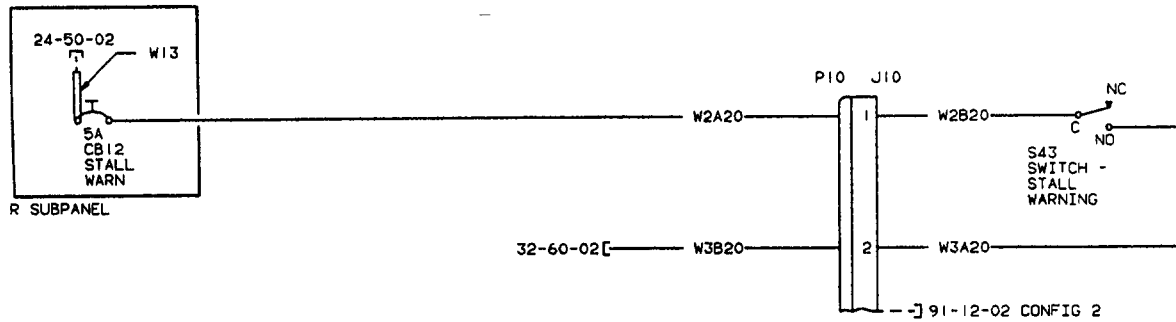

STALL WARNING
(Configuration 2)

Beechcraft
BONANZA
WIRING DIAGRAM MANUAL

REFERENCE DESIGNATOR	PART NUMBER	DESCRIPTION	USABLE	
			INSTL ZONE	ON CODE
27-31-02 (Configuration 2)				
CB12	7277-2-5	CIRCUIT BREAKER-STALL WARNING	240	1
J10A	206036-3	RECEPTACLE-LEFT WHEELWELL ACCESS	532	1
J10B	206070-1	STRAIN RELIEF	532	1
J10C	66103-2	PIN CONTACT	532	1
J10D	66099-2	PIN CONTACT	532	1
P10A	206037-1	PLUG-LEFT WHEELWELL ACCESS	532	1
P10B	66101-2	SOCKET CONTACT	532	1
P10C	66105-2	SOCKET CONTACT	532	1
P10D	206070-1	STRAIN RELIEF CLAMP	532	1
S43	151-10	SWITCH-STALL WARNING	531	1
W13	114931-1-12	BUS-MAIN	240	1

EFFECTIVITY CODE

1. CE-1301, CE-1307 AND AFTER; CJ-180 AND AFTER

Beechcraft
BONANZA
WIRING DIAGRAM MANUAL

27-32-01

**CE-748, CE-772 AND AFTER; CJ-149 AND AFTER; D-10097, D-10120
AND AFTER**

Beechcraft BONANZA WIRING DIAGRAM MANUAL

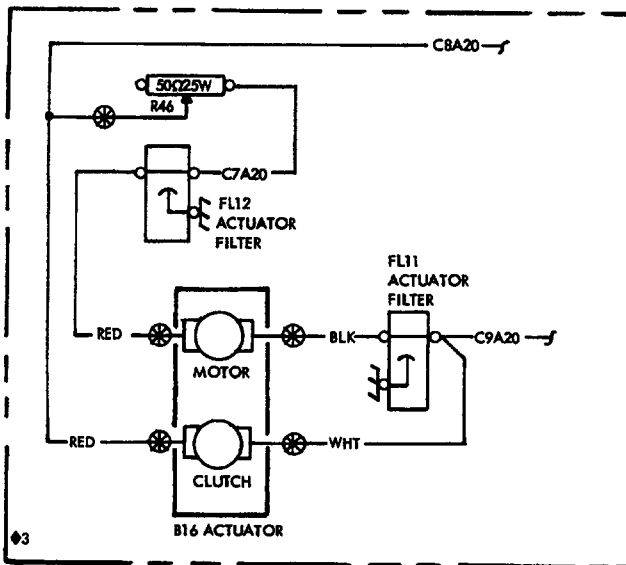
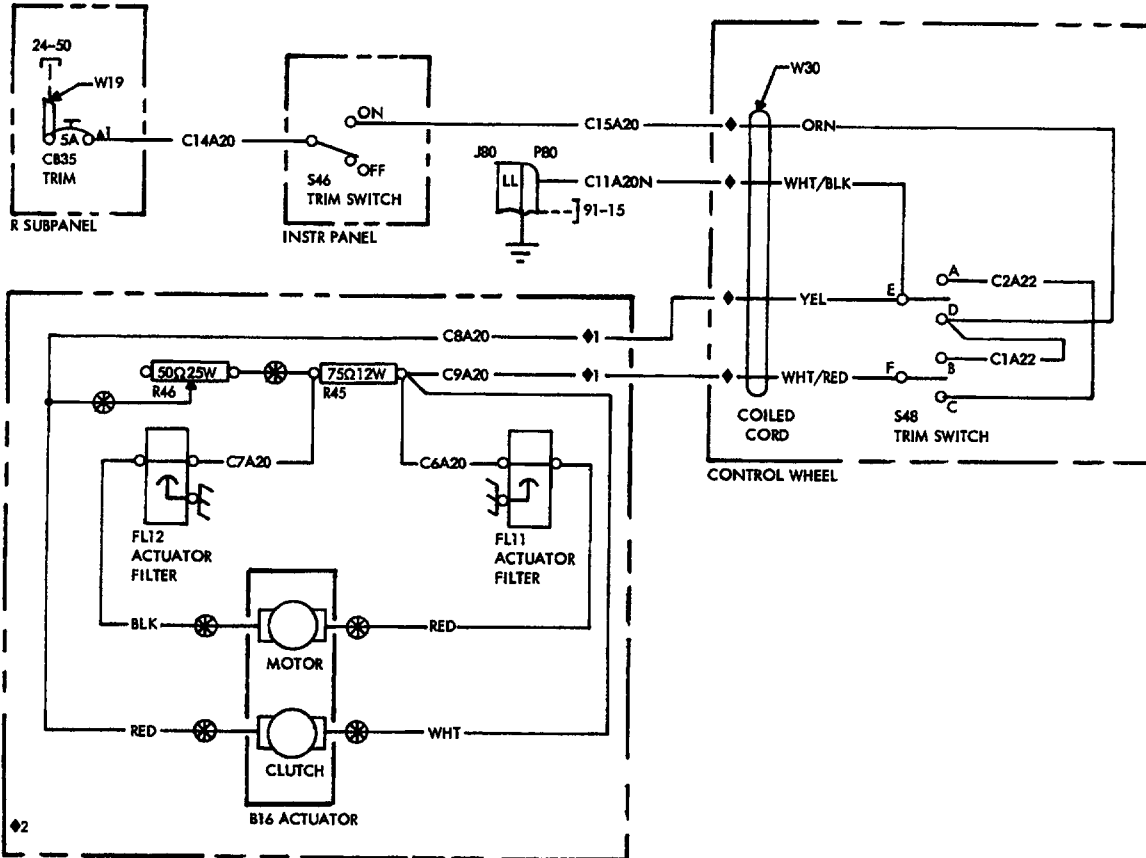

◆1 ON AIRCRAFT D-10097 & D-10120 THRU D-10183, WIRE CBA CONNECTS TO WHT/RED & C9A CONNECTS TO YELLOW.

◆2 ON AIRCRAFT CE-748, CE-772 & AFT, CJ-149 & AFT, D-10097 & D-10120 THRU D-10183.

◆3 ON AIRCRAFT E-10184 & AFT.

◆ REFER TO APPLICABLE AVIONICS DWG FOR MODE OF CONNECTION.

ELEVATOR TRIM (OPTIONAL)

Beechcraft
BONANZA
WIRING DIAGRAM MANUAL

REFERENCE DESIGNATOR	PART NUMBER	DESCRIPTION	USABLE	
			INSTL ZONE	ON CODE
27-32-01				
B16A	33-524023-31	ACTUATOR ASSEMBLY-ELEVATOR TRIM (OPTL)	310	5
B16A	33-524023-33	ACTUATOR ASSEMBLY-ELEVATOR TRIM (OPTL)	310	6
B16B	50-380125	CLUTCH ASSEMBLY (OPTL)	310	5
B16B	50-380125	CLUTCH ASSEMBLY (OPTL)	310	6
B16C	319A209-4	MOTOR (OPTL)	310	5
B16C	319A209-1	MOTOR (OPTL)	310	6
CB35	435-205-104	CIRCUIT BREAKER-ELEVATOR TRIM	240	2
CB35	7277-2-5	CIRCUIT BREAKER-ELEVATOR TRIM	240	3
FL11	A1437	FILTER-TRIM ACTUATOR (OPTL)	310	1
FL12	A1437	FILTER-TRIM ACTUATOR (OPTL)	310	1
J80	204814-1	RECEPTACLE-GROUNDING BLOCK	231	1
P80A	200838-3	PLUG-GROUNDING BLOCK	231	1
P80B	201224-1	STRAIN RELIEF	231	1
P80C	201328-1	SOCKET CONTACT	231	1
P80D	200333-1	SOCKET CONTACT	231	1
P80E	203618-1	JACKSCREW	231	1
R45	4587	RESISTOR-TRIM (OPTL)	310	4
R46	0366	RHEOSTAT-TRIM (OPTL)	310	1
S46	MST-105D	SWITCH-TRIM (OPTL)	240	1
S48	26006	SWITCH-TRIM CONTROL WHEEL	240	1
W30	101-384082-3	COILED CORD-CONTROL WHEEL, PILOT	240	1

EFFECTIVITY CODE

1. CE-748, CE-772 AND AFTER; CJ-149 AND AFTER; D-10097, D-10120 AND AFTER
2. CE-748, CE-772 THRU CE-918, CE-920 THRU CE-928; CJ-149 THRU CJ-155; D-10097, D-10120 THRU D-10347, D-10349 THRU D-10353
3. CE-919, CE-929 AND AFTER; CJ-156 AND AFTER; D-10348, D-10354 AND AFTER
4. CE-748, CE-772 AND AFTER; CJ-149 AND AFTER; D-10097, D-10120 THRU D-10183
5. CE-748, CE-772 THRU CE-878; CJ-149 THRU CJ-155
6. CE-879 AND AFTER; CJ-156 AND AFTER

Beechcraft
BONANZA
WIRING DIAGRAM MANUAL

27-50-01

**E-1111, E-1241 THRU E-1370; CE-748, CE-772 THRU CE-815; CJ-149
ONLY; D-10097, D-10120 THRU D-10178**

Beechcraft
BONANZA
WIRING DIAGRAM MANUAL

REFERENCE DESIGNATOR	PART NUMBER	DESCRIPTION	USABLE	
			INSTL ZONE	ON CODE
27-50-01				
B22	D160-00-3	MOTOR-FLAP	251	1
CB17	435-215-104	CIRCUIT BREAKER-FLAP MOTOR	240	1
J10A	206037-1	PLUG-LEFT WHEELWELL ACCESS	532	1
J10B	206070-1	STRAIN RELIEF	532	1
J10C	66101-2	SOCKET CONTACT	532	1
J10D	66105-2	SOCKET CONTACT	532	1
J80	204814-1	RECEPTACLE-GROUNDING BLOCK	231	1
P10A	206036-3	RECEPTACLE-LEFT WHEEL WELL ACCESS	532	1
P10B	206070-1	STRAIN RELIEF	532	1
P10C	66103-2	PIN CONTACT	532	1
P10D	66099-2	PIN CONTACT	532	1
P74A	1-480318-0	PLUG-FLAP MOTOR	251	1
P74B	60619-1	SOCKET CONTACT	251	1
P80A	200838-3	PLUG-GROUNDING BLOCK	231	1
P80B	201224-1	STRAIN RELIEF	231	1
P80C	201328-1	SOCKET CONTACT	231	1
P80D	200333-1	SOCKET CONTACT	231	1
P80E	203618-1	JACKSCREW	231	1
S50	MS25026-1	SWITCH-FLAP UP LIMIT	531	1
S51	MS25026-1	SWITCH-FLAP DOWN LIMIT	531	1
S52	MS25126-B1	SWITCH-FLAP CONTROL	240	1
W19	114931-1-10	BUS-SECONDARY	240	1

EFFECTIVITY CODE

1. E-1111, E-1241 THRU E-1370; CE-748, CE-772 THRU CE-815; CJ-149 ONLY; D-10097, D-10120 THRU D-10178

Beechcraft
BONANZA
WIRING DIAGRAM MANUAL

27-50-02

Configuration 1

**E-1371 THRU E-1945, E-1947 THRU E-2103, E-2105 THRU E-2110;
CE-816 THRU CE-1300, CE-1302 THRU CE-1306; CJ-150 THRU CJ-179;
D-10179 AND AFTER; EA-1 THRU EA-319, EA-321 THRU EA-388**

Beechcraft BONANZA WIRING DIAGRAM MANUAL

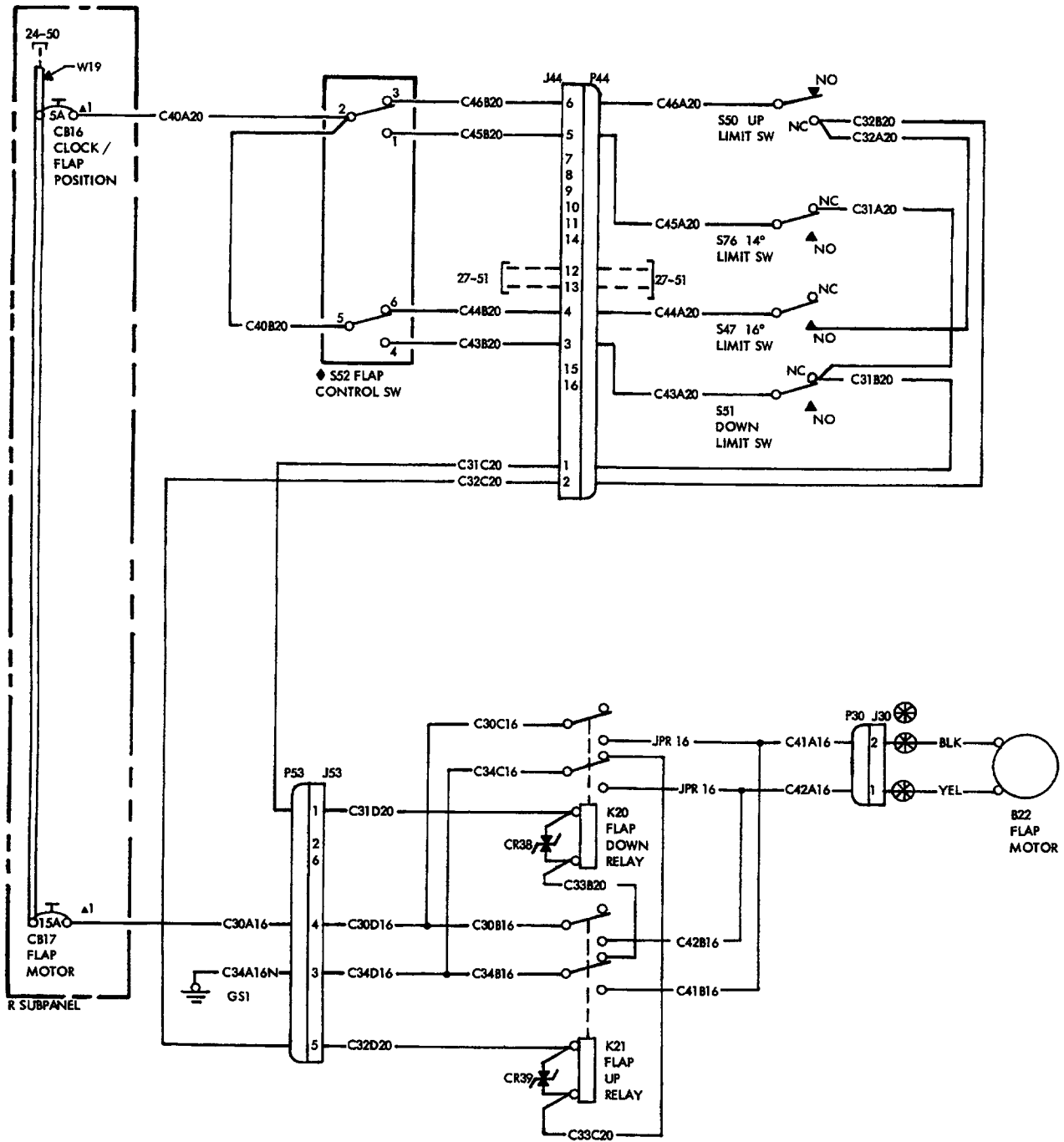

NOTE: FLAPS SHOWN IN UP POSITION.

◆ 3 POSITION SWITCH CODE:

- UP = 2-3, 5-6
- 15° = 2-1, 5-6
- DN = 2-1, 5-4

FLAPS-MOTOR (Configuration 1)

Beechcraft
BONANZA
WIRING DIAGRAM MANUAL

REFERENCE DESIGNATOR	PART NUMBER	DESCRIPTION	USABLE	
			INSTL ZONE	ON CODE
27-50-02 (Configuration 1)				
B22	D160-00-3	MOTOR-FLAP	150	1
CB16	435-205-104	CIRCUIT BREAKER-CLOCK/FLAP POSITION	240	2
CB16	7277-2-5	CIRCUIT BREAKER-CLOCK/FLAP POSITION	240	3
CB17	MS24510-15	CIRCUIT BREAKER-CLOCK/FLAP POSITION	240	3
CB17	435-215-104	CIRCUIT BREAKER-CLOCK/FLAP POSITION	240	2
CR38	1.5KE51CA	TRANSZORB-FLAP DOWN RELAY	251	1
CR39	1.5KE51CA	TRANSZORB-FLAP UP RELAY	251	1
GS1	131270-3	GROUND STUD-MAIN SPAR	270	1
J30A	1-480288-0	RECEPTACLE-LIGHT DIMMING TRANSMITTER BRACKET	140	1
J30B	60618-1	PIN CONTACT	140	1
J44A	206036-3	RECEPTACLE-FLAP LIMIT SWITCH	532	1
J44B	66103-2	PIN CONTACT	532	1
J44C	206070-1	STRAIN RELIEF	532	1
J53A	1-480340-0	RECEPTACLE-FLAP RELAY	251	1
J53B	60618-1	PIN CONTACT	150	1
J53C	60620-1	PIN CONTACT	150	1
K20	50-380048-1	RELAY-FLAP DOWN	251	1
K21	50-380048-1	RELAY-FLAP UP	251	1
P30A	1-480287-0	PLUG-LIGHT DIMMING TRANSMITTER BRACKET	140	1
P30B	60617-1	SOCKET CONTACT	140	1
P44A	206037-1	PLUG-FLAP LIMIT SWITCH	532	1
P44B	66105-2	SOCKET CONTACT	532	1
P44C	206070-1	STRAIN RELIEF	532	1
P53A	1-480270-0	PLUG-FLAP RELAY	251	1
P53B	60617-1	SOCKET CONTACT	150	1
P53C	60619-1	SOCKET CONTACT	150	1
S47	MS25026-1	SWITCH-16 DEGREE LIMIT	531	1
S50	MS25026-1	SWITCH-FLAP UP LIMIT	533	1
S51	MS25026-1	SWITCH-FLAP DOWN LIMIT	533	1
S52	8858K82	SWITCH-FLAP CONTROL	240	1
S76	MS25026-1	SWITCH-14 DEGREE LIMIT	531	1
W19	114931-1-10	BUS-SECONDARY	240	1

EFFECTIVITY CODE

1. E-1371 THRU E-1945, E-1947 THRU E-2103, E-2105 THRU E-2110; CE-816 THRU CE-1300, CE-1302 THRU CE-1306; CJ-150 THRU CJ-179; D-10179 AND AFTER; EA-1 THRU EA-319, EA-321 THRU EA-388

2. E-1371 THRU E-1765; CE-816 THRU CE-918, CE-920 THRU CE-928; CJ-150 THRU CJ-155; D-10179 THRU D-10347, D-10349 THRU D-10353; EA-1 THRU EA-158

3. E-1766 THRU E-1945, E-1947 THRU E-2103, E-2105 THRU E-2110; CE-919, CE-929 THRU CE-1300, CE-1302 THRU CE-1306; CJ-156 THRU CJ-179; D-10348, D-10354 AND AFTER; EA-159 THRU EA-319, EA-321 THRU EA-388

Beechcraft
BONANZA
WIRING DIAGRAM MANUAL

27-50-02

Configuration 2

CE-1301, CE-1307 AND AFTER; CJ-180 AND AFTER

Beechcraft BONANZA WIRING DIAGRAM MANUAL

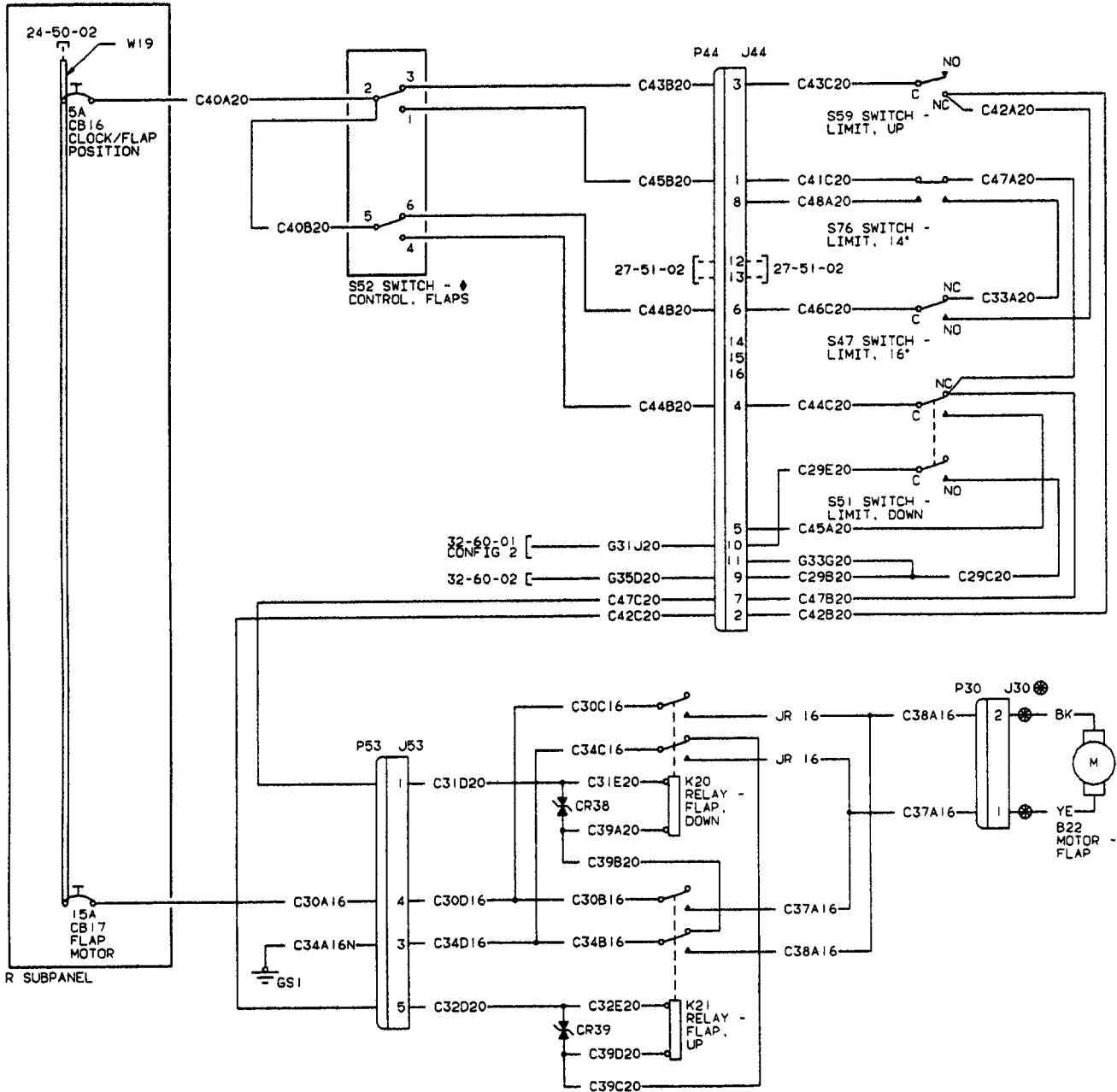

NOTE: FLAPS SHOWN IN UP POSITION.

- ◆ 3 POSITION SWITCH CODE
 UP 2-3, 5-6
 15' 2-1, 5-6
 DN 2-1, 5-4

FLAPS-MOTOR (Configuration 2)

Beechcraft
BONANZA
WIRING DIAGRAM MANUAL

REFERENCE DESIGNATOR	PART NUMBER	DESCRIPTION	USABLE	
			INSTL ZONE	ON CODE
27-50-02 (Configuration 2)				
B22	D160-00-3	MOTOR-FLAP	150	1
CB16	7277-2-5	CIRCUIT BREAKER-CLOCK/FLAP POSITION	240	1
CB17	MS24510-15	CIRCUIT BREAKER-CLOCK/FLAP POSITION	240	1
CR38	1.5KE51CA	TRANSZORB-FLAP DOWN RELAY	251	1
CR39	1.5KE51CA	TRANSZORB-FLAP UP RELAY	251	1
GS1	131270-3	GROUND STUD-MAIN SPAR	270	1
J30A	1-480288-0	RECEPTACLE-LIGHT DIMMING TRANSMITTER BRACKET	140	1
J30B	60618-1	PIN CONTACT	140	1
J44A	206036-3	RECEPTACLE-FLAP LIMIT SWITCH	532	1
J44B	66103-2	PIN CONTACT	532	1
J44C	206070-1	STRAIN RELIEF	532	1
J53A	1-480340-0	RECEPTACLE-FLAP RELAY	251	1
J53B	60618-1	PIN CONTACT	150	1
J53C	60620-1	PIN CONTACT	150	1
K20	50-380048-1	RELAY-FLAP DOWN	251	1
K21	50-380048-1	RELAY-FLAP UP	251	1
P30A	1-480287-0	PLUG-LIGHT DIMMING TRANSMITTER BRACKET	140	1
P30B	60617-1	SOCKET CONTACT	140	1
P44A	206037-1	PLUG-FLAP LIMIT SWITCH	532	1
P44B	66105-2	SOCKET CONTACT	532	1
P44C	206070-1	STRAIN RELIEF	532	1
P53A	1-480270-0	PLUG-FLAP RELAY	251	1
P53B	60617-1	SOCKET CONTACT	150	1
P53C	60619-1	SOCKET CONTACT	150	1
S47	MS25026-1	SWITCH-16 DEGREE LIMIT	531	1
S51	MS25006-1	SWITCH-FLAP DOWN LIMIT	531	1
S52	8858K82	SWITCH-FLAP CONTROL	240	1
S59	MS25026-1	SWITCH-FLAP UP LIMIT	531	1
S76	BZ-3AT	SWITCH-14 DEGREE FLAP LIMIT	533	1
W19	114931-1-10	BUS-SECONDARY	240	1

EFFECTIVITY CODE

1. CE-1301, CE-1307 AND AFTER; CJ-180 AND AFTER

Beechcraft
BONANZA
WIRING DIAGRAM MANUAL

27-51-01

**E-1111, E-1241 THRU E-1370; CE-748, CE-772 THRU CE-815; D-10097,
D-10120 THRU D-10178; EA-1 ONLY**

Beechcraft BONANZA WIRING DIAGRAM MANUAL

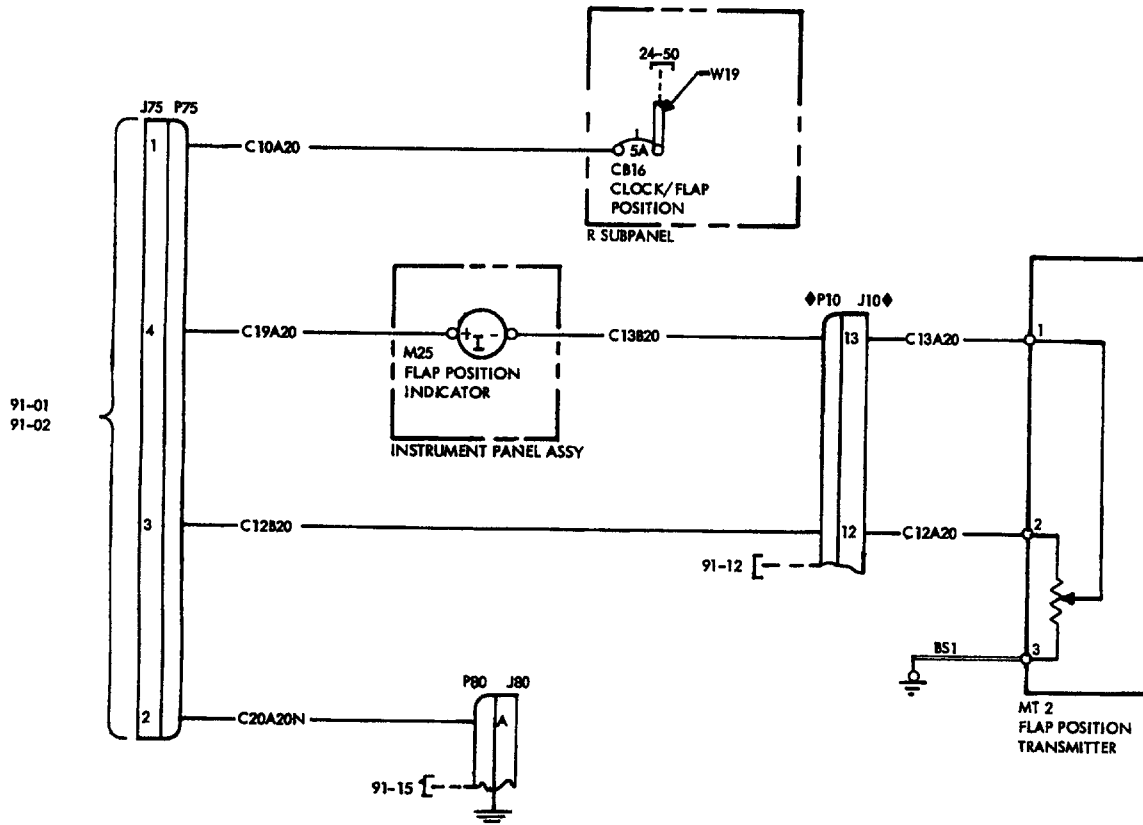

◆ ON AIRCRAFT EA-1 ONLY, RCPT J44 REPLACES PLUG P10, PLUG P44 REPLACES RCPT J10 AND REF DIAG 27-50 REPLACES 91-12.

FLAPS-POSITION INDICATOR

Beechcraft
BONANZA
WIRING DIAGRAM MANUAL

REFERENCE DESIGNATOR	PART NUMBER	DESCRIPTION	USABLE	
			INSTL ZONE	ON CODE
27-51-01				
BS1	MS25083-1BA6	BONDING STRAP-FLAP TRANSMITTER	533	1
CB16	435-205-104	CIRCUIT BREAKER-CLOCK/FLAP POSITION	240	1
J10A	206036-3	RECEPTACLE-LEFT WHEELWELL ACCESS	532	1
J10B	206070-1	STRAIN RELIEF	532	1
J10C	66103-2	PIN CONTACT	532	1
J10D	66099-2	PIN CONTACT	532	1
J75A	1-480426-0	RECEPTACLE-FLAP POSITION INDICATOR	231	1
J75B	60618-1	PIN CONTACT	231	1
J80	204814-1	RECEPTACLE-GROUNDING BLOCK	231	1
MT2	58-380009-1	TRANSMITTER-FLAP POSITION	533	1
M25	58-384001-35	INDICATOR-FLAP POSITION	250	1
P10A	206037-1	PLUG-LEFT WHEELWELL ACCESS	532	1
P10B	66101-2	SOCKET CONTACT	532	1
P10C	66105-2	SOCKET CONTACT	532	1
P10D	206070-1	STRAIN RELIEF CLAMP	532	1
P75A	1-480424-0	PLUG-FLAP INDICATOR	231	1
P75B	60617-1	SOCKET CONTACT	231	1
P80A	200838-3	PLUG-GROUNDING BLOCK	231	1
P80B	201224-1	STRAIN RELIEF	231	1
P80C	201328-1	SOCKET CONTACT	231	1
P80D	200333-1	SOCKET CONTACT	231	1
P80E	203618-1	JACKSCREW	231	1
W19	114931-1-10	BUS-SECONDARY	240	1

EFFECTIVITY CODE

1. E-1111, E-1241 THRU E-1370; CE-748, CE-772 THRU CE-815; D-10097, D-10120 THRU D-10178;
EA-1 ONLY

Beechcraft
BONANZA
WIRING DIAGRAM MANUAL

27-51-02

**E-1371 THRU E-1945, E-1947 THRU E-2103, E-2105 THRU E-2110;
CE-816 AND AFTER; CJ-149 AND AFTER; D-10179 AND AFTER; EA-2
THRU EA-319, EA-321 THRU EA-388**

Beechcraft BONANZA WIRING DIAGRAM MANUAL

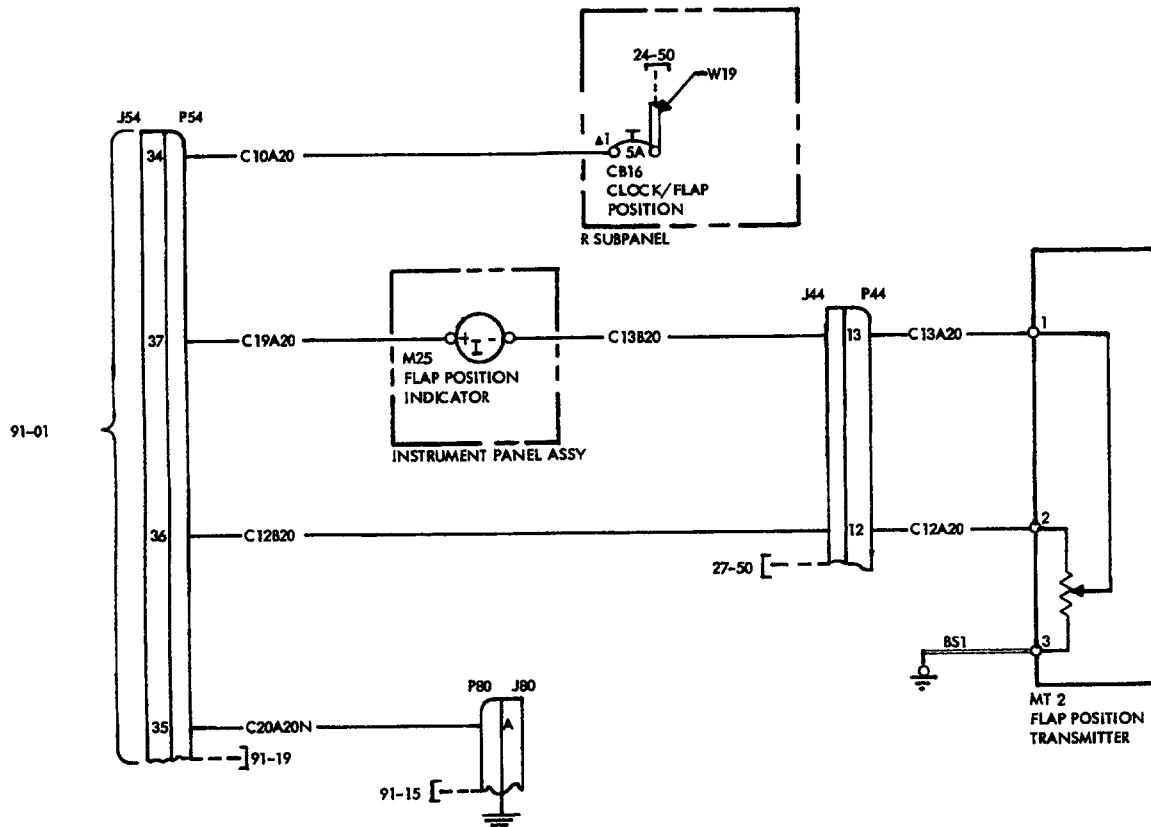

FLAPS-POSITION INDICATOR

Beechcraft
BONANZA
WIRING DIAGRAM MANUAL

REFERENCE DESIGNATOR	PART NUMBER	DESCRIPTION	USABLE INSTL ON ZONE CODE
27-51-02			
BS1	MS25083-1BA6	BONDING STRAP-FLAP TRANSMITTER	533 1
CB16	435-205-104	CIRCUIT BREAKER-CLOCK/FLAP POSITION	240 2
CB16	7277-2-5	CIRCUIT BREAKER-CLOCK/FLAP POSITION	240 3
J44A	206036-3	RECEPTACLE-FLAP LIMIT SWITCH	532 1
J44B	66103-2	PIN CONTACT	532 1
J44C	206070-1	STRAIN RELIEF	532 1
J54A	206151-2	RECEPTACLE-JUNCTION BOX ASSEMBLY	231 1
J54B	206138-1	STRAIN RELIEF	231 1
J54C	66103-2	PIN CONTACT	231 1
J80	204814-1	RECEPTACLE-GROUNDING BLOCK	231 1
MT2	58-380009-1	TRANSMITTER-FLAP POSITION	533 1
M25	58-384001-35	INDICATOR-FLAP POSITION	250 1
P44A	206037-1	PLUG-FLAP LIMIT SWITCH	532 1
P44B	66105-2	SOCKET CONTACT	532 1
P44C	206070-1	STRAIN RELIEF	532 1
P54A	206150-1	PLUG-JUNCTION BOX ASSEMBLY	231 1
P54B	206138-1	STRAIN RELIEF	231 1
P54C	66105-2	SOCKET CONTACT	231 1
P80A	200838-3	PLUG-GROUNDING BLOCK	231 1
P80B	201224-1	STRAIN RELIEF	231 1
P80C	201328-1	SOCKET CONTACT	231 1
P80D	200333-1	SOCKET CONTACT	231 1
P80E	203618-1	JACKSCREW	231 1
W19	114931-1-10	BUS-SECONDARY	240 1

EFFECTIVITY CODE

1. E-1371 THRU E-1945, E-1947 THRU E-2103, E-2105 THRU E-2110; CE-816 AND AFTER; CJ-149 AND AFTER; D-10179 AND AFTER; EA-2 THRU EA-319, EA-321 THRU EA-388
2. E-1371 THRU E-1765; CE-816 THRU CE-918, CE-920 THRU CE-928; CJ-149 THRU CJ-155; D-10179 THRU D-10347, D-10349 THRU D-10353; EA-2 THRU EA-158
3. E-1766 THRU E-1945, E-1947 THRU E-2103, E-2105 THRU E-2110; CE-919, CE-929 AND AFTER; CJ-156 AND AFTER; D-10348, D-10354 AND AFTER; EA-159 THRU EA-319, EA-321 THRU EA-388

CHAPTER

28

FUEL

Beechcraft
BONANZA
WIRING DIAGRAM MANUAL
LIST OF PAGES & TABLE OF CONTENTS
for
CHAPTER 28 - FUEL

SYS/SUB-SYS/ CHAP SECTION	PAGE NO.	EFFECTIVE DATE	TABLE OF CONTENTS
28-20-01	Page 1	OCT/95	FUEL PUMP-AUXILIARY
	Page 2	OCT/95	
	Page 3	OCT/95	
28-20-02	Page 1	OCT/95	FUEL PUMP-AUXILIARY
	Page 2	OCT/95	
	Page 3	OCT/95	
28-20-03 (Config 1)	Page 1	OCT/95	FUEL PUMP-AUXILIARY
	Page 2	OCT/95	
	Page 3	OCT/95	
28-20-03 (Config 2)	Page 1	OCT/95	FUEL PUMP-AUXILIARY
	Page 2	OCT/95	
	Page 3	OCT/95	
28-20-03 (Config 3)	Page 1	OCT/95	FUEL PUMP-AUXILIARY
	Page 2	OCT/95	
	Page 3	OCT/95	
28-20-04	Page 1	OCT/95	FUEL PUMP-AUXILIARY
	Page 2	OCT/95	
	Page 3	OCT/95	
28-20-05	Page 1	OCT/95	FUEL PUMP-AUXILIARY
	Page 2	OCT/95	
	Page 3	OCT/95	
28-40-01	Page 1	OCT/95	INDICATING-FUEL QUANTITY
	Page 2	OCT/95	
	Page 3	OCT/95	
	Page 4	OCT/95	
	Page 5	OCT/95	
28-40-02	Page 1	OCT/95	INDICATING-FUEL QUANTITY
	Page 2	OCT/95	
	Page 3	OCT/95	
	Page 4	OCT/95	
	Page 5	OCT/95	
28-40-03	Page 1	OCT/95	INDICATING-FUEL QUANTITY
	Page 2	OCT/95	
	Page 3	OCT/95	
	Page 4	OCT/95	
	Page 5	OCT/95	
28-40-04	Page 1	OCT/95	INDICATING-FUEL QUANTITY
	Page 2	OCT/95	
	Page 3	OCT/95	
28-40-05	Page 1	OCT/95	INDICATING-FUEL QUANTITY
	Page 2	OCT/95	
	Page 3	OCT/95	
	Page 4	OCT/95	
	Page 5	OCT/95	

Beechcraft
BONANZA
WIRING DIAGRAM MANUAL

28-20-01

**E-1111, E-1241 THRU E-1551; CE-748, CE-772 THRU CE-871; D-10097,
D-10120 THRU D-10268**

Beechcraft
BONANZA
WIRING DIAGRAM MANUAL

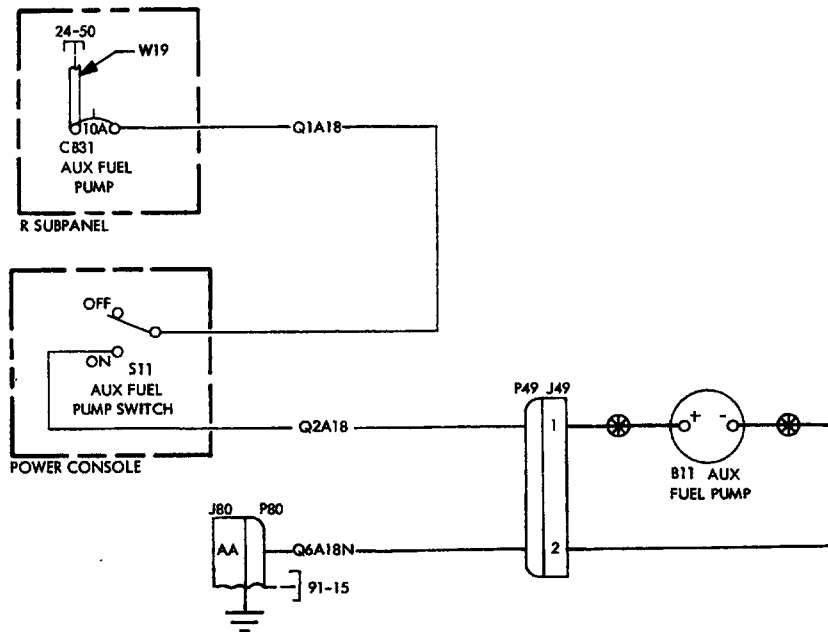

FUEL PUMP-AUXILIARY

Beechcraft
BONANZA
WIRING DIAGRAM MANUAL

REFERENCE DESIGNATOR	PART NUMBER	DESCRIPTION	USABLE	
			INSTL ZONE	ON CODE
28-20-01				
B11	1296-00-1	PUMP-AUXILIARY FUEL	140	1
CB31	435-210-104	CIRCUIT BREAKER-AUXILIARY FUEL PUMP	240	1
J49A	1-480319-0	RECEPTACLE-AUXILIARY FUEL PUMP	140	1
J49B	60618-1	PIN CONTACT	140	1
J80	204814-1	RECEPTACLE-GROUNDING BLOCK	231	1
P49A	1-480318-0	PLUG-AUXILIARY FUEL PUMP	140	1
P49B	60617-1	SOCKET CONTACT	140	1
P80A	200838-3	PLUG-GROUNDING BLOCK	231	1
P80B	201224-1	STRAIN RELIEF	231	1
P80C	201328-1	SOCKET CONTACT	231	1
P80D	200333-1	SOCKET CONTACT	231	1
P80E	203618-1	JACKSCREW	231	1
S11	35-380053-21	SWITCH-AUXILIARY FUEL PUMP	240	1
W19	114931-1-10	BUS-SECONDARY	240	1

EFFECTIVITY CODE

1. E-1111, E-1241 THRU E-1551; CE-748, CE-772 THRU CE-871; D-10097, D-10120 THRU D-10268

Beechcraft
BONANZA
WIRING DIAGRAM MANUAL

28-20-02

CJ-149 AND CJ-150

Beechcraft BONANZA WIRING DIAGRAM MANUAL

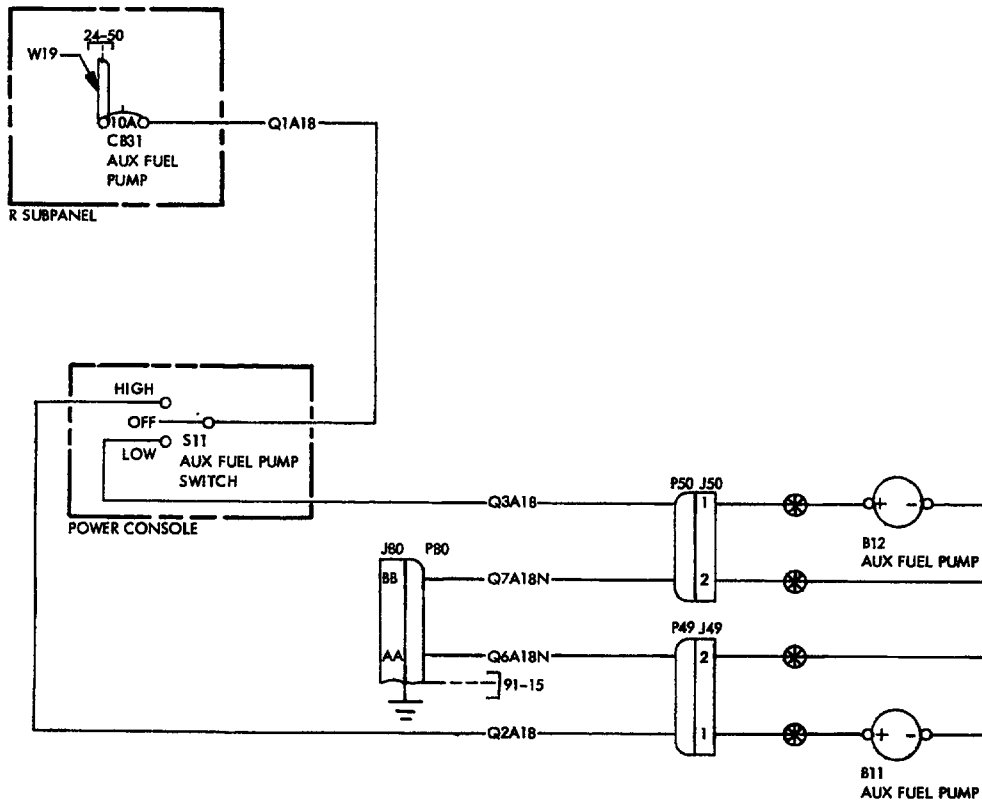

FUEL PUMP-AUXILIARY

Beechcraft
BONANZA
WIRING DIAGRAM MANUAL

REFERENCE DESIGNATOR	PART NUMBER	DESCRIPTION	USABLE	
			INSTL	ON ZONE CODE
28-20-02				
B11	1296-00-1	PUMP-HIGH AUXILIARY FUEL	140	1
B12	1297-00-1	PUMP-LOW AUXILIARY FUEL	140	1
CB31	435-210-104	CIRCUIT BREAKER-AUXILIARY FUEL PUMP	240	1
J49A	1-480319-0	RECEPTACLE-AUXILIARY FUEL PUMP	140	1
J49B	60618-1	PIN CONTACT	140	1
J50A	1-480319-0	RECEPTACLE HOUSING-AUXILIARY FUEL PUMP	140	1
J50B	60618-1	PIN CONTACT	140	1
J80	204814-1	RECEPTACLE-GROUNDING BLOCK	231	1
P49A	1-480318-0	PLUG-AUXILIARY FUEL PUMP	140	1
P49B	60617-1	SOCKET CONTACT	140	1
P50A	1-480319-0	PLUG HOUSING-AUXILIARY FUEL PUMP	140	1
P50B	60617-1	SOCKET CONTACT	140	1
P80A	200838-3	PLUG-GROUNDING BLOCK	231	1
P80B	201224-1	STRAIN RELIEF	231	1
P80C	201328-1	SOCKET CONTACT	231	1
P80D	200333-1	SOCKET CONTACT	231	1
P80E	203618-1	JACKSCREW	231	1
S11	35-380053-21	SWITCH-AUXILIARY FUEL PUMP	240	1
W19	114931-1-10	BUS-SECONDARY	240	1

EFFECTIVITY CODE

1. CJ-149 AND CJ-150

Beechcraft
BONANZA
WIRING DIAGRAM MANUAL

28-20-03

Configuration 1

**EA-1 THRU EA-241, EA-243 THRU EA-272 (PRIOR TO INSTALLATION
OF KIT 36-9008-1S)**

Beechcraft BONANZA WIRING DIAGRAM MANUAL

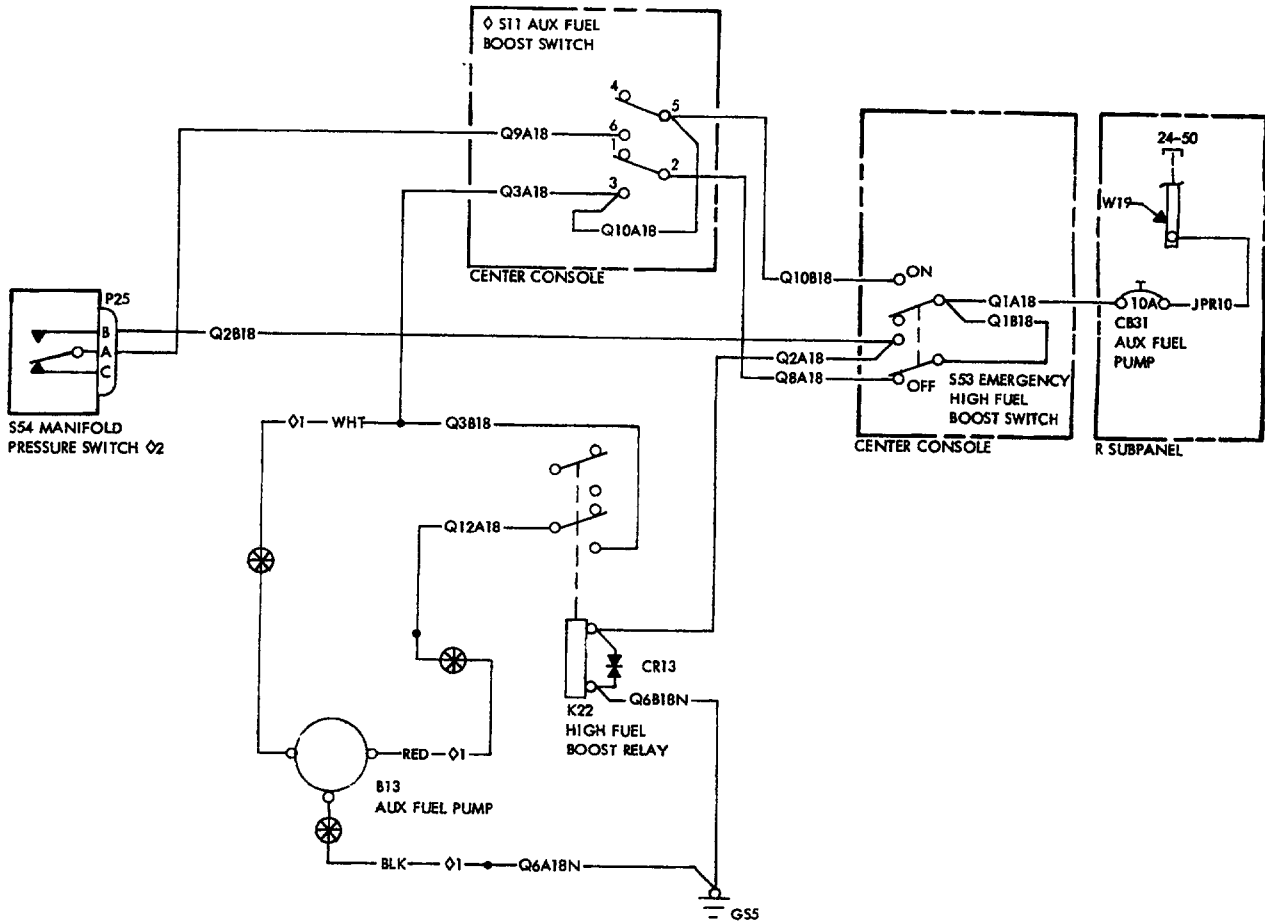

Q2 SHOWN AT PRESSURE BELOW 27" H_g ABS.

Q1 COLOR CODES MAY BE:
GND - BLUE
LOW - RED
HIGH - YELLOW

Q AUX FUEL BOOST SWITCH OPERATION
AUTO 2-3, 5-6
LOW 2-3, 5-4
OFF 2-1, 5-4

FUEL PUMP-AUXILIARY (Configuration 1)

Beechcraft
BONANZA
WIRING DIAGRAM MANUAL

REFERENCE DESIGNATOR	PART NUMBER	DESCRIPTION	USABLE INSTL ON ZONE CODE
28-20-03 (Configuration 1)			
B13	2B7-34	PUMP-AUXILIARY FUEL	270 1
CB31	435-210-104	CIRCUIT BREAKER-AUXILIARY FUEL PUMP	240 2
CB31	7277-2-10	CIRCUIT BREAKER-AUXILIARY FUEL PUMP	240 3
CR13	1.5KE51CA	TRANSZORB-FUEL BOOST POWER	150 1
GS5	131270-3	GROUND STUD	140 1
K22	50-380048-1	RELAY-AUXILIARY FUEL BOOST	150 1
P25	MS3106A-10SL-3S	PLUG-MANIFOLD PRESSURE SWITCH	231 1
S11	MS27408-1M	SWITCH-AUXILIARY FUEL PUMP	240 1
S53	MS24659-23D	SWITCH-EMERGENCY HIGH FUEL BOOST	240 1
S54	E45C-55	SWITCH-MANIFOLD PRESSURE	231 1
W19	114931-1-10	BUS-SECONDARY	240 1

EFFECTIVITY CODE

1. EA-1 THRU EA-241, EA-243 THRU EA-272 (PRIOR TO INSTALLATION OF KIT 36-9008-1S)
2. EA-1 THRU EA-158 (PRIOR TO INSTALLATION OF KIT 36-9008-1S)
3. EA-159 THRU EA-241, EA-243 THRU EA-272 (PRIOR TO INSTALLATION OF KIT 36-9008-1S)

Beechcraft
BONANZA
WIRING DIAGRAM MANUAL

28-20-03

Configuration 2

EA-242, EA-273 THRU EA-319, EA-321 THRU EA-388

Beechcraft BONANZA WIRING DIAGRAM MANUAL

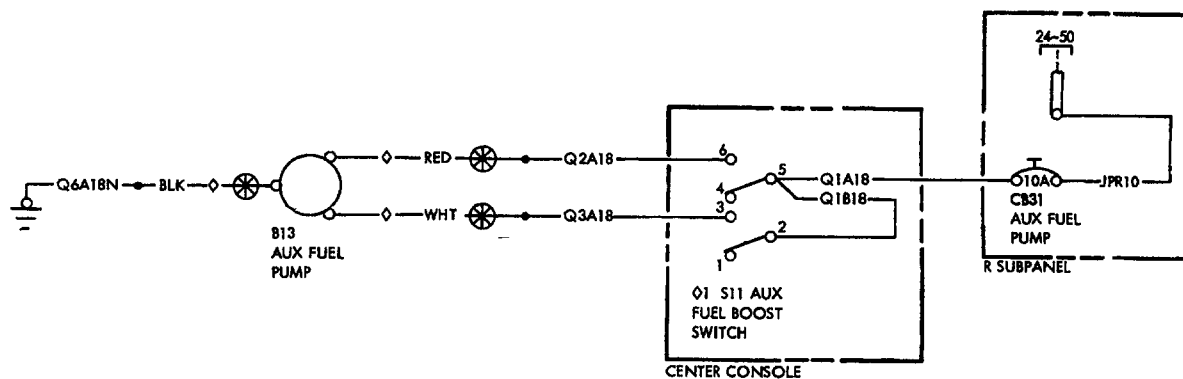

◇ COLOR CODES MAY BE
 GND - BLUE
 LOW - RED
 HIGH - YELLOW

◇1 AUX FUEL BOOST SWITCH OPERATION:
 HIGH - 2-3,5-6
 LOW - 2-3,5-4
 OFF - 2-1,5-4

FUEL PUMP-AUXILIARY (Configuration 2)

Beechcraft
BONANZA
WIRING DIAGRAM MANUAL

REFERENCE DESIGNATOR	PART NUMBER	DESCRIPTION	USABLE	
			INSTL	ON ZONE CODE
28-20-03 (Configuration 2)				
B13	2B7-34	PUMP-AUXILIARY FUEL	140	1
CB31	7277-2-10	CIRCUIT BREAKER-AUXILIARY FUEL PUMP SWITCH	240	1
S11	MS27408-1N	SWITCH-AUXILIARY FUEL PUMP	240	1

EFFECTIVITY CODE

1. EA-242, EA-273 THRU EA-319, EA-321 THRU EA-388

Beechcraft
BONANZA
WIRING DIAGRAM MANUAL

28-20-03

Configuration 3

**EA-1 THRU EA-241, EA-243 THRU EA-272 (AFTER INSTALLATION OF
KIT 36-9008-1S PER S.B. 2033)**

Beechcraft BONANZA WIRING DIAGRAM MANUAL

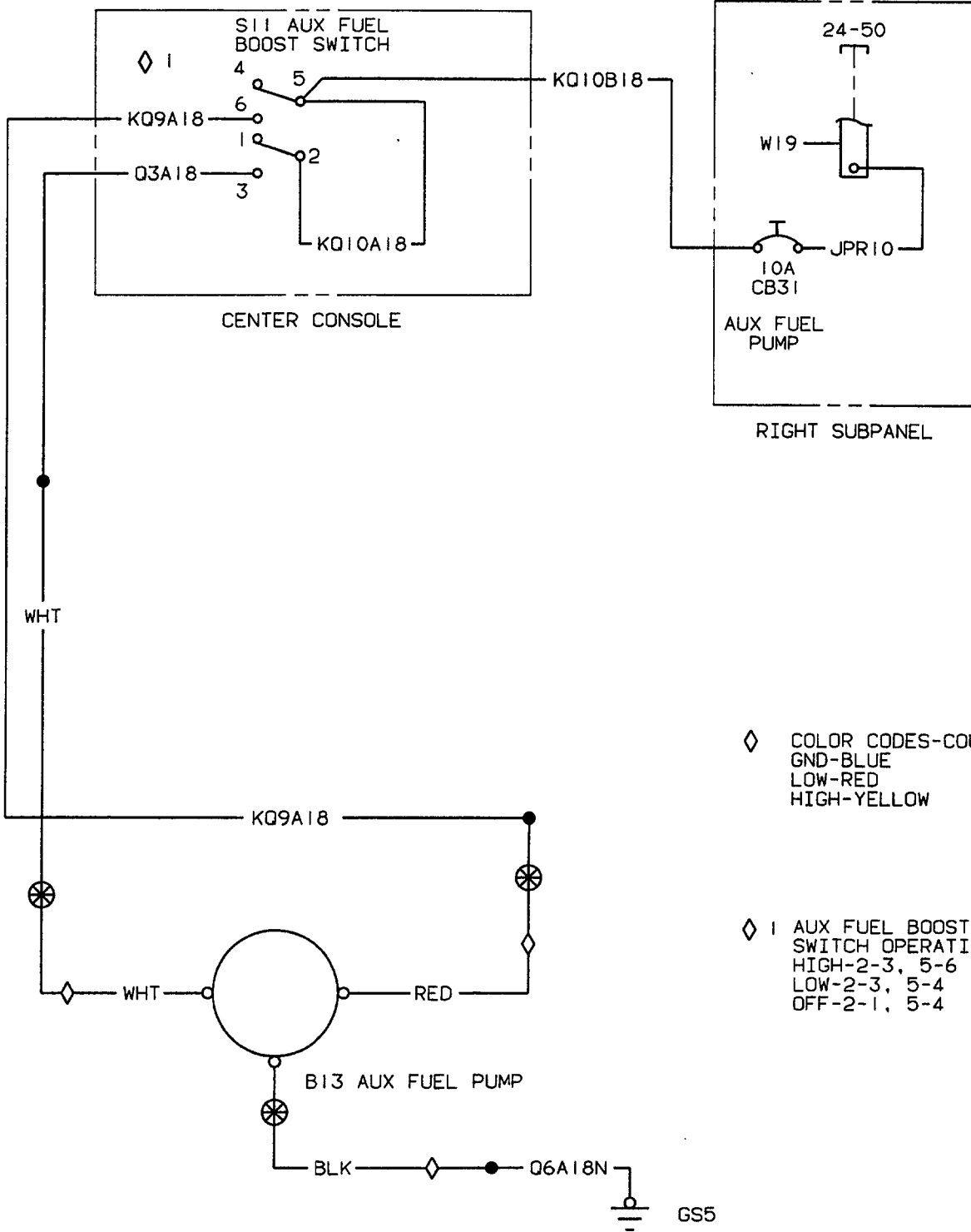

◇ COLOR CODES-COULD BE
GND-BLUE
LOW-RED
HIGH-YELLOW

◇ 1 AUX FUEL BOOST
SWITCH OPERATION
HIGH-2-3, 5-6
LOW-2-3, 5-4
OFF-2-1, 5-4

**FUEL PUMP-AUXILIARY
(Configuration 3)**

Beechcraft
BONANZA
WIRING DIAGRAM MANUAL

REFERENCE DESIGNATOR	PART NUMBER	DESCRIPTION	USABLE INSTL ON ZONE CODE
28-20-03 (Configuration 3)			
	36-9008-1S	KIT-FUEL SYSTEM INSTALLATION (CONTAINS COMPONENTS AND INSTRUCTIONS TO INSTALL B36TC FUEL SELECTOR VALVE ON AIRPLANES EFFECTIVE EA-1 THRU EA-241, EA-243 THRU EA-272 PER SERVICE BULLETIN 2033)	140 1
B13	2B7-34	PUMP-AUXILIARY FUEL	140 1
CB31	7277-2-10	CIRCUIT BREAKER-AUXILIARY FUEL PUMP SWITCH	140 3
CB31	435-210-104	CIRCUIT BREAKER-AUXILIARY FUEL PUMP SWITCH	140 2
GS5	131270-3	GROUND STUD	231 1
S11	MS27408-1N	SWITCH-AUXILIARY FUEL PUMP	240 1
W19	114931-1-10	BUS-SECONDARY	240 1

EFFECTIVITY CODE

1. EA-1 THRU EA-241, EA-243 THRU EA-272 (AFTER INSTALLATION OF KIT 36-9008-1S PER S.B. 2033)
2. EA-1 THRU EA-158 (AFTER INSTALLATION OF KIT 36-9008-1S PER B.S. 2033)
3. EA-159 THRU EA-241, EA-243 THRU EA-272 (AFTER INSTALLATION OF KIT 36-9008-1S PER B.S. 2033)

Beechcraft
BONANZA
WIRING DIAGRAM MANUAL

28-20-04

**E-1552 THRU E-1945, E-1947 THRU E-2103, E-2105 THRU E-2110;
CE-872 AND AFTER; D-10269 AND AFTER**

Beechcraft BONANZA WIRING DIAGRAM MANUAL

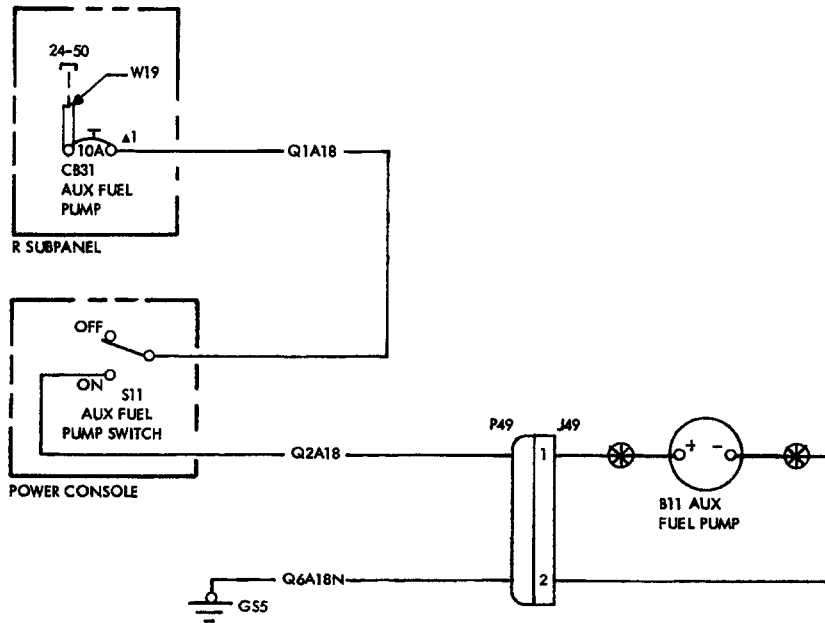

FUEL PUMP-AUXILIARY

Beechcraft
BONANZA
WIRING DIAGRAM MANUAL

REFERENCE DESIGNATOR	PART NUMBER	DESCRIPTION	USABLE	
			INSTL	ON ZONE CODE
28-20-04				
B11	1296-00-1	PUMP-AUXILIARY FUEL	140	1
CB31	7277-2-10	CIRCUIT BREAKER-AUXILIARY FUEL PUMP SWITCH	140	3
CB31	435-210-104	CIRCUIT BREAKER-AUXILIARY FUEL PUMP SWITCH	140	2
GS5	131270-3	GROUND STUD	231	1
J49A	1-480319-0	RECEPTACLE-AUXILIARY FUEL PUMP	140	1
J49B	60618-1	PIN CONTACT	140	1
P49A	1-480318-0	PLUG-AUXILIARY FUEL PUMP	140	1
P49B	60617-1	SOCKET CONTACT	140	1
S11	35-380053-21	SWITCH-AUXILIARY FUEL PUMP	240	1
W19	114931-1-10	BUS-SECONDARY	240	1

EFFECTIVITY CODE

1. E-1552 THRU E-1945, E-1947 THRU E-2103, E-2105 THRU E-2110; CE-872 AND AFTER; D-10269 AND AFTER
2. E-1552 THRU E-1765; CE-872 THRU CE-918, CE-920 THRU CE-928; D-10269 THRU D-10347, D-10349 THRU D-10353
3. E-1766 THRU E-1945, E-1947 THRU E-2103, E-2105 THRU E-2110; CE-919, CE-929 AND AFTER; D-10348, D-10354 AND AFTER

Beechcraft
BONANZA
WIRING DIAGRAM MANUAL

28-20-05

CJ-151 AND AFTER

Beechcraft BONANZA WIRING DIAGRAM MANUAL

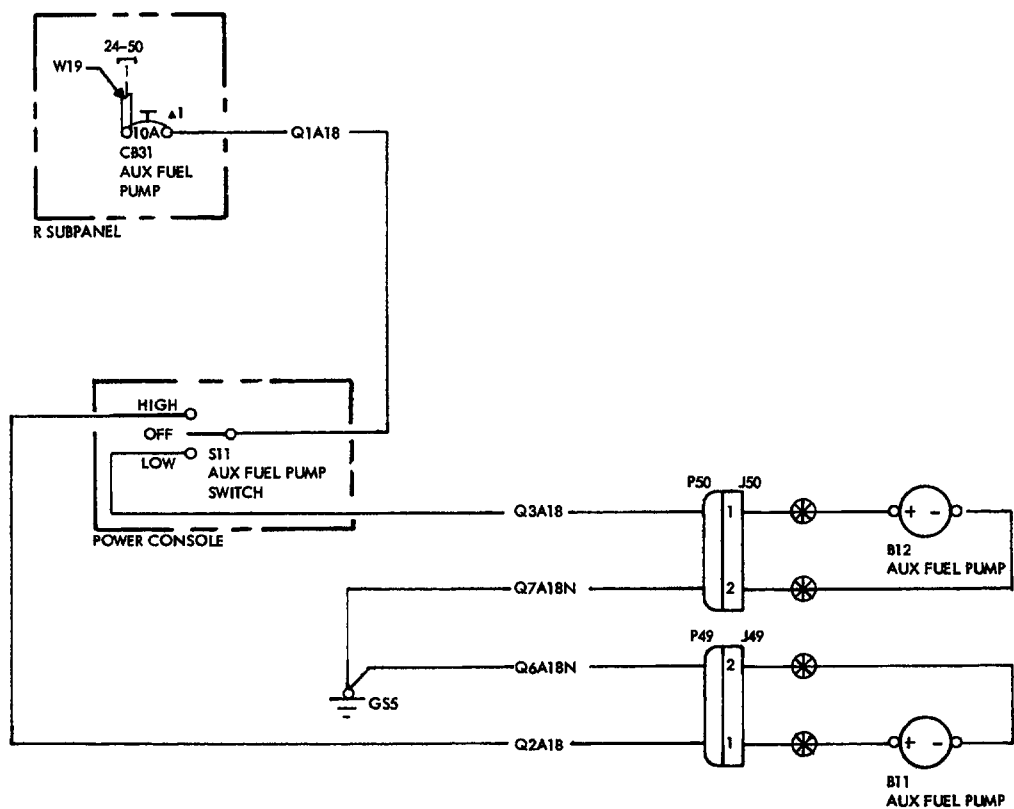

FUEL PUMP-AUXILIARY

Beechcraft
BONANZA
WIRING DIAGRAM MANUAL

REFERENCE DESIGNATOR	PART NUMBER	DESCRIPTION	USABLE	
			INSTL	ON ZONE CODE
28-20-05				
B11	1296-00-1	PUMP-AUXILIARY FUEL	140	1
B12	1297-00-1	PUMP-AUXILIARY FUEL	140	1
CB31	7277-2-10	CIRCUIT BREAKER-AUXILIARY FUEL PUMP SWITCH	140	3
CB31	435-210-104	CIRCUIT BREAKER-AUXILIARY FUEL PUMP SWITCH	140	2
GS5	131270-3	GROUND STUD	231	1
J49A	1-480319-0	RECEPTACLE-AUXILIARY FUEL PUMP	140	1
J49B	60618-1	PIN CONTACT	140	1
J50A	1-480319-0	RECEPTACLE HOUSING-AUXILIARY FUEL PUMP	140	1
J50B	60618-1	PIN CONTACT	140	1
P49A	1-480318-0	PLUG-AUXILIARY FUEL PUMP	140	1
P49B	60617-1	SOCKET CONTACT	140	1
P50A	1-480318-0	PLUG HOUSING-AUXILIARY FUEL PUMP	140	1
P50B	60617-1	SOCKET CONTACT	140	1
S11	35-380053-21	SWITCH-AUXILIARY FUEL PUMP	240	1
W19	114931-1-10	BUS-SECONDARY	240	1

EFFECTIVITY CODE

1. CJ-151 AND AFTER
2. CJ-151 THRU CJ-155
3. CJ-156 AND AFTER

Beechcraft
BONANZA
WIRING DIAGRAM MANUAL

28-40-01

**E-1111, E-1241 THRU E-1370; CE-748, CE-772 THRU CE-815; CJ-149
ONLY; D-10097, D-10120 THRU D-10178**

Beechcraft BONANZA WIRING DIAGRAM MANUAL

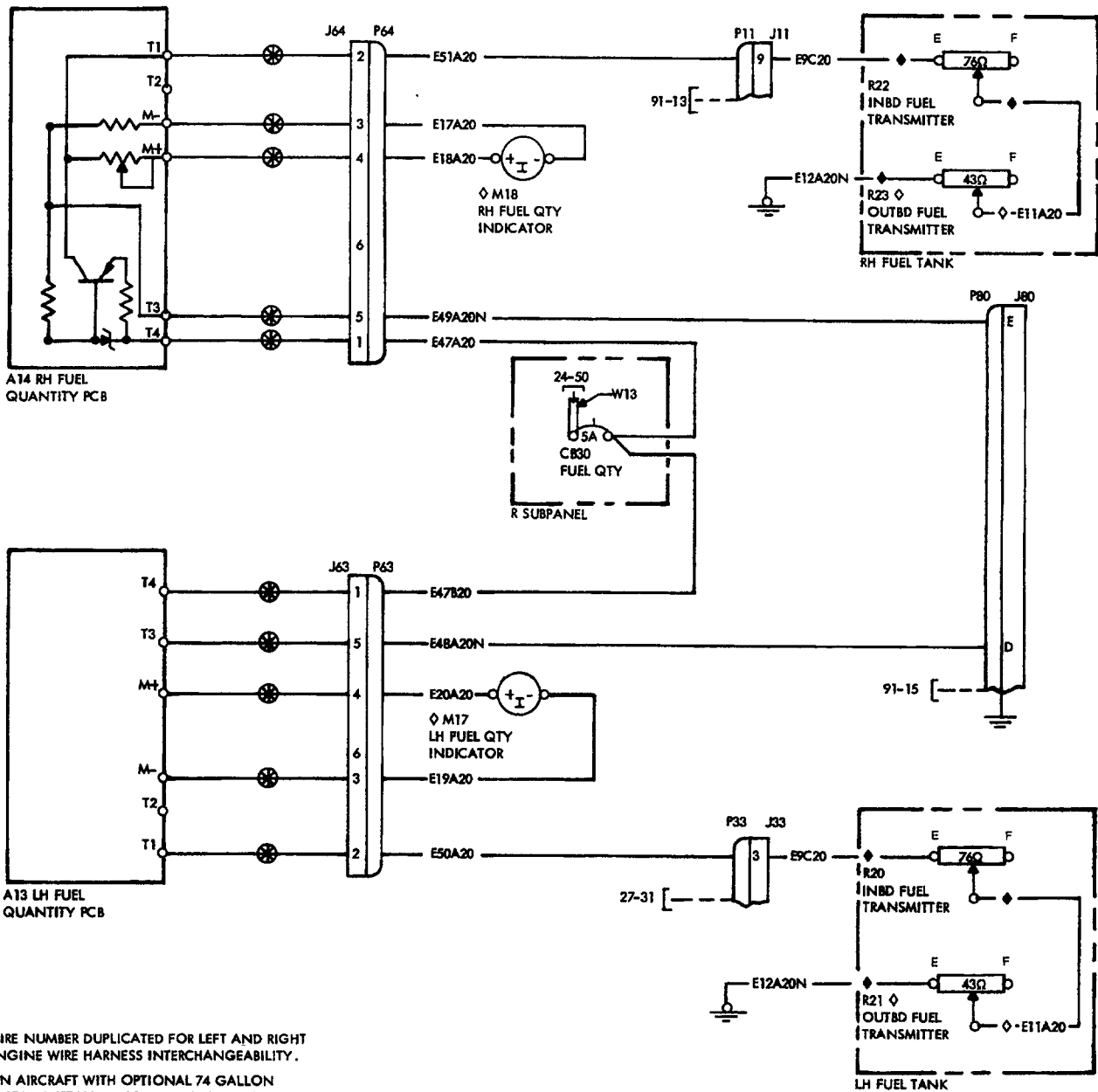

- ◆ WIRE NUMBER DUPLICATED FOR LEFT AND RIGHT ENGINE WIRE HARNESS INTERCHANGEABILITY.
- ◇ ON AIRCRAFT WITH OPTIONAL 74 GALLON SYSTEM INSTALLED, R21 & R23 TRANSMITTERS AND WIRE E11A20 IS USED AND M29 AND M30 FUEL QTY INDICATORS REPLACE M17 AND M18 RESPECTIVELY.

INDICATING-FUEL QUANTITY

Beechcraft
BONANZA
WIRING DIAGRAM MANUAL

REFERENCE DESIGNATOR	PART NUMBER	DESCRIPTION	USABLE	
			INSTL ZONE	ON CODE
28-40-01				
A13	58-364041-9	PRINTED CIRCUIT BOARD-FUEL QUANTITY,LEFT	240	1
A14	58-364041-9	PRINTED CIRCUIT BOARD-FUEL QUANTITY,RIGHT	240	1
CB30	435-205-104	CIRCUIT BREAKER-FUEL QUANTITY	240	1
J11A	206036-3	RECEPTACLE-WHEEL WELL ACCESS, RIGHT	632	1
J11B	206070-1	STRAIN RELIEF	632	1
J11C	66099-2	PIN CONTACT	632	1
J11D	66103-2	PIN CONTACT	632	1
J33A	206153-1	RECEPTACLE-STALL WARNING HORN	532	1
J33B	66099-2	SOCKET CONTACT	532	1
J33C	66103-2	SOCKET CONTACT	532	1
J33D	206062-1	STRAIN RELIEF	532	1
J63A	1-480340-0	RECEPTACLE-LEFT FUEL QUANTITY PRINTED CIRCUIT BOARD	240	1
J63B	60618-1	PIN CONTACT	240	1
J64A	1-480340-0	RECEPTACLE-RIGHT FUEL QUANTITY PRINTED CIRCUIT BOARD	240	1
J64B	60618-1	PIN CONTACT	240	1
J80	204814-1	RECEPTACLE-GROUNDING BLOCK	231	1
M17	58-380050-11	INDICATOR-LEFT FUEL QUANTITY (ALTN FOR 58-380074-11)	240	1
M17	58-380074-11	INDICATOR-LEFT FUEL QUANTITY (ALTN FOR 58-380050-11)	240	1
M18	58-380050-11	INDICATOR-RIGHT FUEL QUANTITY (ALTN FOR 58-380074-11)	240	1
M18	58-380074-11	INDICATOR-RIGHT FUEL QUANTITY (ALTN FOR 58-380050-11)	240	1
M29	58-380051	INDICATOR-LEFT FUEL QUANTITY (OPTL)	240	1
M30	58-380051	INDICATOR-RIGHT FUEL QUANTITY (OPTL)	240	1
P11A	206037-1	PLUG-WHEEL WELL ACCESS, RIGHT	632	1
P11B	206070-1	STRAIN RELIEF	632	1
P11C	66101-2	SOCKET CONTACT	632	1
P11D	66105-2	SOCKET CONTACT	632	1
P33A	206060-1	PLUG-STALL WARNING HORN	532	1
P33B	66101-2	SOCKET CONTACT	532	1
P33C	66105-2	SOCKET CONTACT	532	1
P33D	206062-1	STRAIN RELIEF	532	1
P63A	1-480270-0	PLUG-LEFT FUEL QUANTITY PRINTED CIRCUIT BOARD	240	1
P63B	60617-1	SOCKET CONTACT	240	1
P64A	1-480270-0	PLUG-RIGHT FUEL QUANTITY PRINTED CIRCUIT BOARD	240	1
P64B	60617-1	SOCKET CONTACT	240	1
P80A	200838-3	PLUG-GROUNDING BLOCK	231	1
P80B	201224-1	STRAIN RELIEF	231	1
P80C	201328-1	SOCKET CONTACT	231	1
P80D	200333-1	SOCKET CONTACT	231	1
P80E	203618-1	JACKSCREW	231	1
R20	96-380041-1	TRANSMITTER-LEFT INBOARD FUEL, SENSOR	531	1
R21	96-380042-1	TRANSMITTER-LEFT OUTBOARD FUEL, SENSOR	631	1
R22	96-380041-1	TRANSMITTER-RIGHT INBOARD FUEL, SENSOR	531	1
R23	96-380042-3	TRANSMITTER-RIGHT OUTBOARD FUEL, SENSOR	631	1

Beechcraft BONANZA WIRING DIAGRAM MANUAL

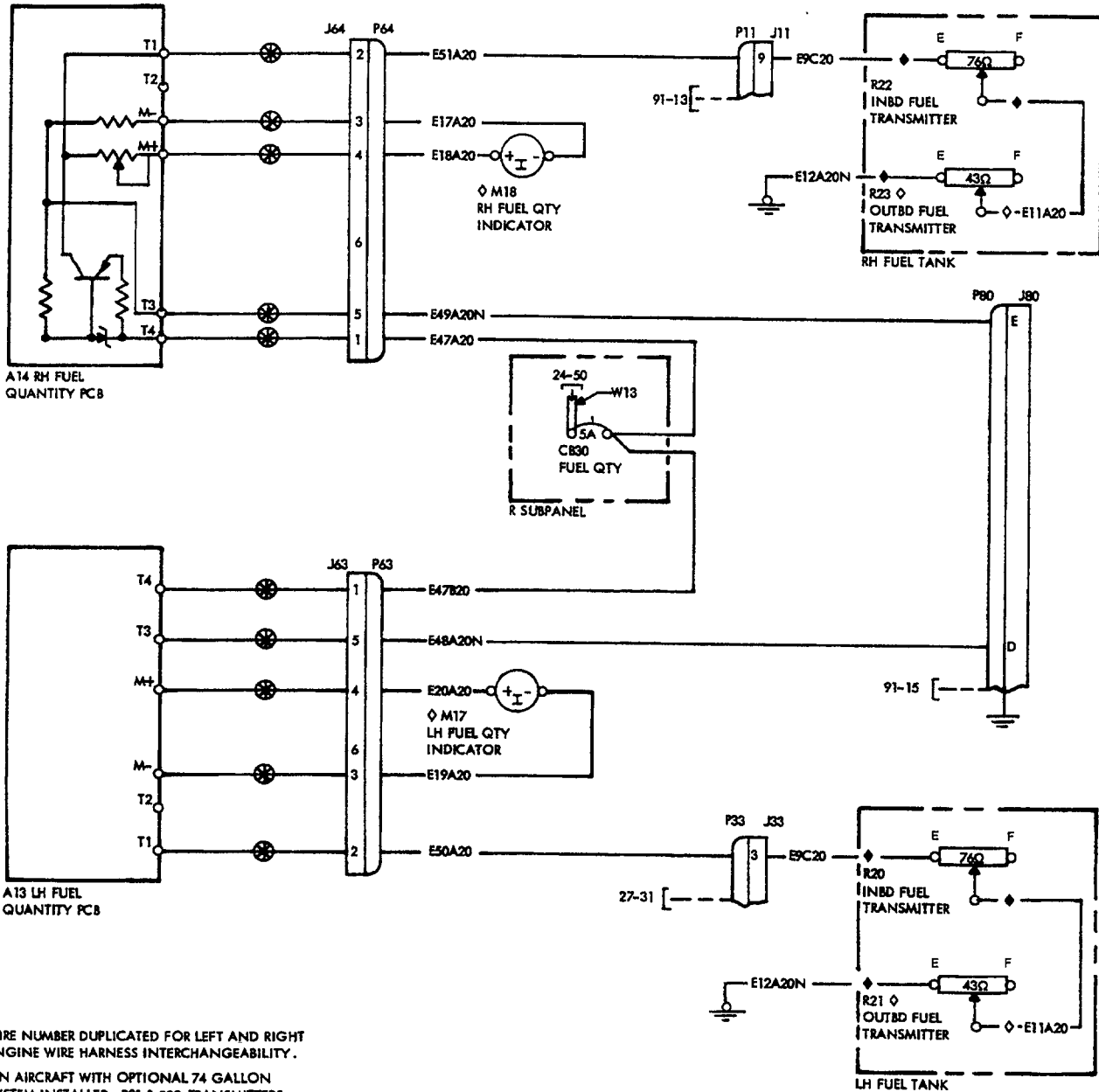

◆ WIRE NUMBER DUPLICATED FOR LEFT AND RIGHT ENGINE WIRE HARNESS INTERCHANGEABILITY.

◇ ON AIRCRAFT WITH OPTIONAL 74 GALLON SYSTEM INSTALLED, R21 & R23 TRANSMITTERS AND WIRE E11A20 IS USED AND M29 AND M30 FUEL QTY INDICATORS REPLACE M17 AND M18 RESPECTIVELY.

INDICATING-FUEL QUANTITY

Beechcraft
BONANZA
WIRING DIAGRAM MANUAL

REFERENCE DESIGNATOR	PART NUMBER	DESCRIPTION	USABLE	
			INSTL ZONE	ON CODE
		28-40-01		
W13	114931-1-12	BUS-MAIN	240	1

EFFECTIVITY CODE

1. E-1111, E-1241 THRU E-1370; CE-748, CE-772 THRU CE-815; CJ-149 ONLY; D-10097, D-10120 THRU D-10178

Beechcraft
BONANZA
WIRING DIAGRAM MANUAL

28-40-02

**E-1371 THRU E-1593; CE-816 THRU CE-883; CJ-150 THRU CJ-155;
D-10179 THRU D-10302; EA-1 THRU EA-32**

Beechcraft BONANZA WIRING DIAGRAM MANUAL

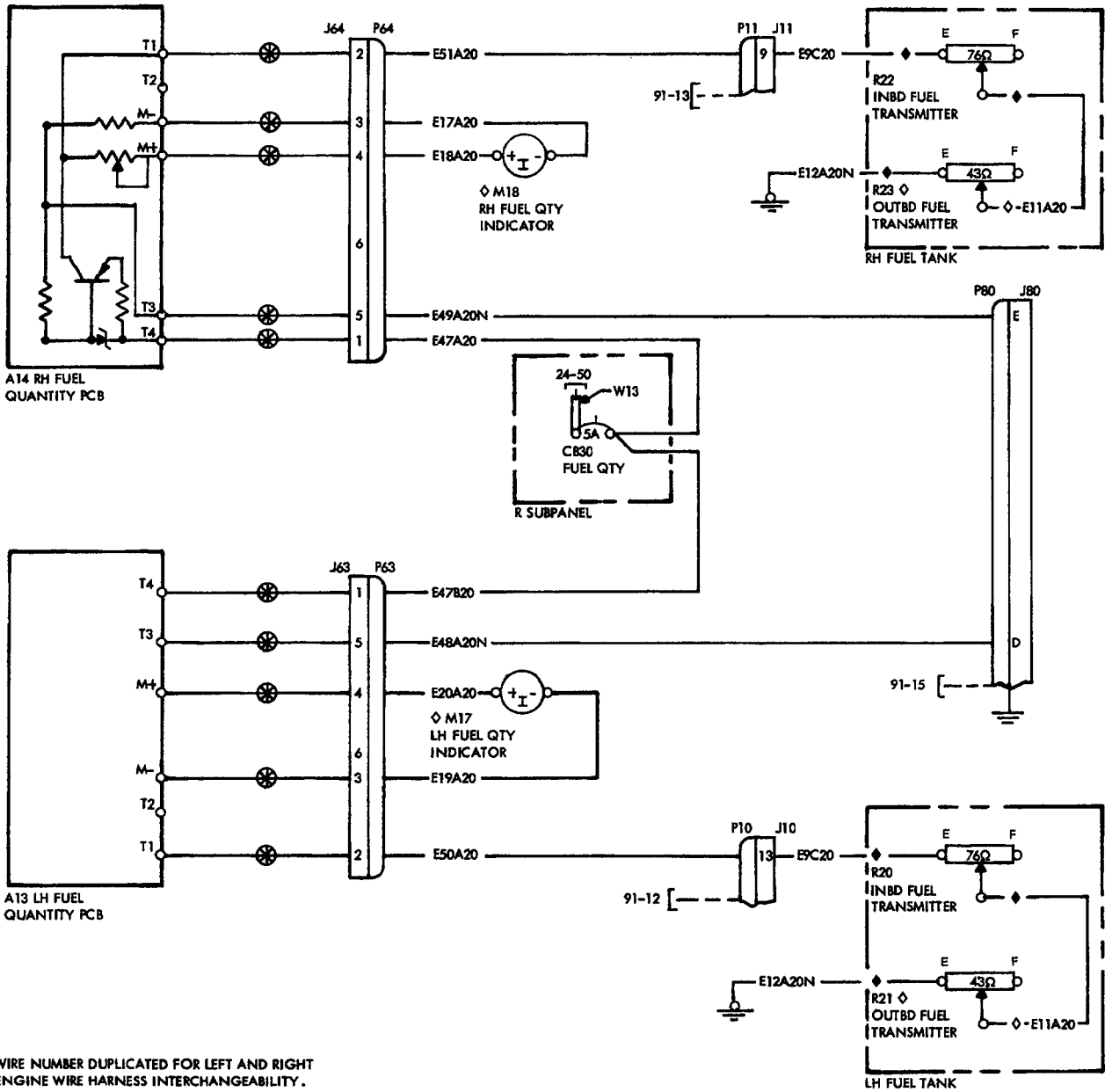

- ◆ WIRE NUMBER DUPLICATED FOR LEFT AND RIGHT ENGINE WIRE HARNESS INTERCHANGEABILITY.
- ◇ ON AIRCRAFT WITH OPTIONAL 74 GALLON SYSTEM INSTALLED, R21 & R23 TRANSMITTERS AND WIRE E11A20 IS USED AND M29 AND M30 FUEL QTY INDICATORS REPLACE M17 AND M18 RESPECTIVELY.

INDICATING-FUEL QUANTITY

Beechcraft
BONANZA
WIRING DIAGRAM MANUAL

REFERENCE DESIGNATOR	PART NUMBER	DESCRIPTION	INSTL ZONE	USABLE ON CODE
28-40-02				
A13	58-364041-9	PRINTED CIRCUIT BOARD-FUEL QUANTITY,LEFT	240	1
A14	58-364041-9	PRINTED CIRCUIT BOARD-FUEL QUANTITY,RIGHT	240	1
CB30	435-205-104	CIRCUIT BREAKER-FUEL QUANTITY	240	1
J10A	206036-3	RECEPTACLE-LEFT WHEEL WELL ACCESS	532	1
J10B	206070-1	STRAIN RELIEF	532	1
J10C	66103-2	PIN CONTACT	532	1
J10D	66099-2	PIN CONTACT	532	1
J11A	206036-3	RECEPTACLE-WHEEL WELL ACCESS, RIGHT	632	1
J11B	206070-1	STRAIN RELIEF	632	1
J11C	66099-2	PIN CONTACT	632	1
J11D	66103-2	PIN CONTACT	632	1
J63A	1-480340-0	RECEPTACLE-LEFT FUEL QUANTITY PRINTED CIRCUIT BOARD	240	1
J63B	60618-1	PIN CONTACT	240	1
J64A	1-480340-0	RECEPTACLE-RIGHT FUEL QUANTITY PRINTED CIRCUIT BOARD	240	1
J64B	60618-1	PIN CONTACT	240	1
J80	204814-1	RECEPTACLE-GROUNDING BLOCK	231	1
M17	58-380050-11	INDICATOR-LEFT FUEL QUANTITY (ALTN FOR 58-380074-11)	240	1
M17	58-380074-11	INDICATOR-LEFT FUEL QUANTITY (ALTN FOR 58-380050-11)	240	1
M18	58-380050-11	INDICATOR-RIGHT FUEL QUANTITY (ALTN FOR 58-380074-11)	240	1
M18	58-380074-11	INDICATOR-RIGHT FUEL QUANTITY (ALTN FOR 58-380050-11)	240	1
M29	58-380051	INDICATOR-LEFT FUEL QUANTITY (OPTL)	240	1
M30	58-380051	INDICATOR-RIGHT FUEL QUANTITY (OPTL)	240	1
P10A	206037-1	PLUG-LEFT WHEEL WELL ACCESS	532	1
P10B	66101-2	SOCKET CONTACT	532	1
P10C	66105-2	SOCKET CONTACT	532	1
P10D	206070-1	STRAIN RELIEF CLAMP	532	1
P11A	206037-1	PLUG-WHEEL WELL ACCESS, RIGHT	632	1
P11B	206070-1	STRAIN RELIEF	632	1
P11C	66101-2	SOCKET CONTACT	632	1
P11D	66105-2	SOCKET CONTACT	632	1
P63A	1-480270-0	PLUG-LEFT FUEL QUANTITY PRINTED CIRCUIT BOARD	240	1
P63B	60617-1	SOCKET CONTACT	240	1
P64A	1-480270-0	PLUG-RIGHT FUEL QUANTITY PRINTED CIRCUIT BOARD	240	1
P64B	60617-1	SOCKET CONTACT	240	1
P80A	200838-3	PLUG-GROUNDING BLOCK	231	1
P80B	201224-1	STRAIN RELIEF	231	1
P80C	201328-1	SOCKET CONTACT	231	1
P80D	200333-1	SOCKET CONTACT	231	1
P80E	203618-1	JACKSCREW	231	1
R20	96-380041-1	TRANSMITTER-LEFT INBOARD FUEL, SENSOR	531	1
R21	96-380042-1	TRANSMITTER-LEFT OUTBOARD FUEL, SENSOR	631	1
R22	96-380041-1	TRANSMITTER-RIGHT INBOARD FUEL, SENSOR	531	1
R23	96-380042-3	TRANSMITTER-RIGHT OUTBOARD FUEL, SENSOR	631	1

Beechcraft BONANZA WIRING DIAGRAM MANUAL

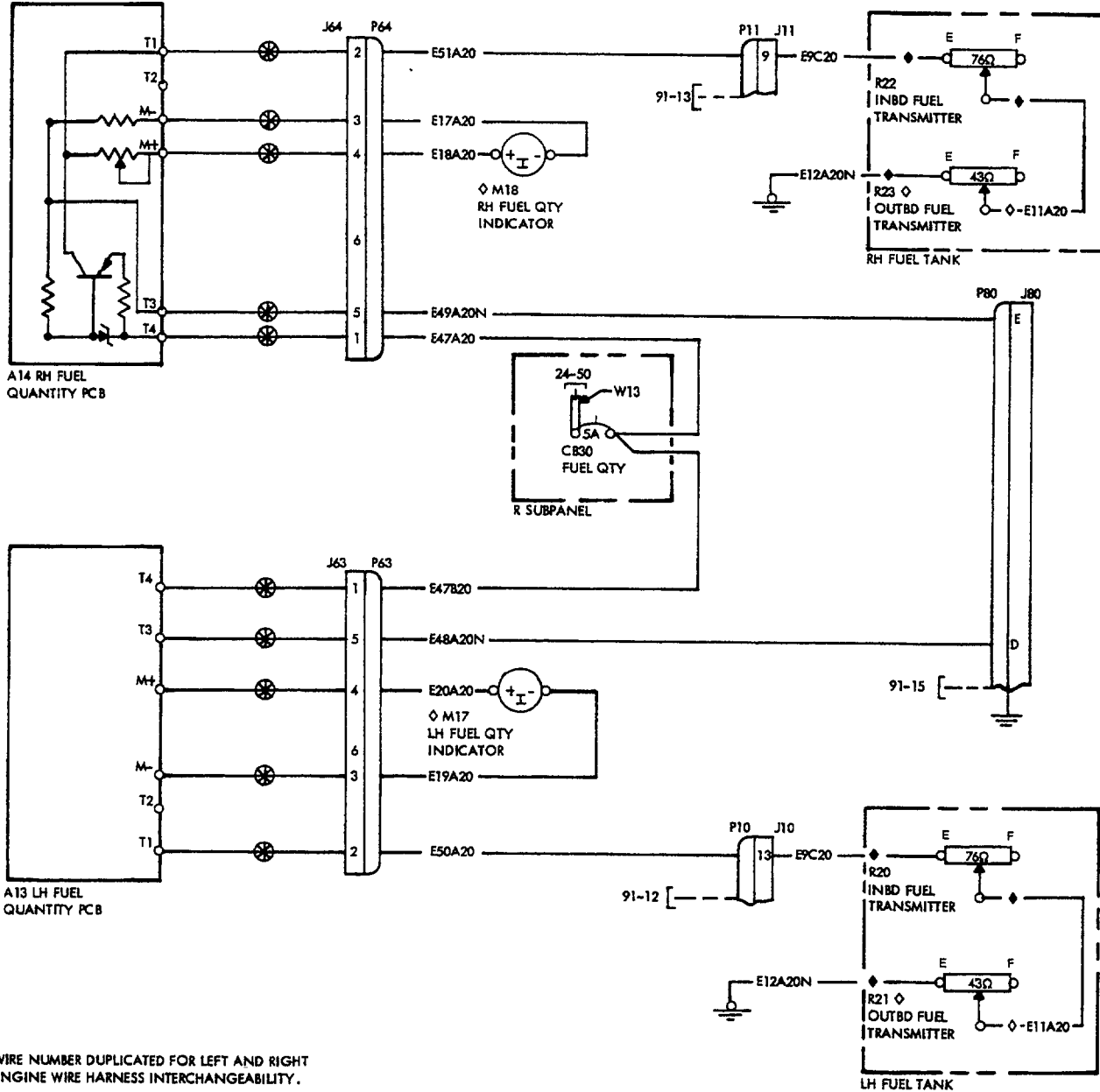

- ◆ WIRE NUMBER DUPLICATED FOR LEFT AND RIGHT ENGINE WIRE HARNESS INTERCHANGEABILITY.
- ◇ ON AIRCRAFT WITH OPTIONAL 74 GALLON SYSTEM INSTALLED, R21 & R23 TRANSMITTERS AND WIRE E11A20 IS USED AND M29 AND M30 FUEL QTY INDICATORS REPLACE M17 AND M18 RESPECTIVELY.

INDICATING-FUEL QUANTITY

Beechcraft
BONANZA
WIRING DIAGRAM MANUAL

REFERENCE DESIGNATOR	PART NUMBER	DESCRIPTION	USABLE INSTL ON ZONE CODE
		28-40-02	
W13	114931-1-12	BUS-MAIN	240 1

EFFECTIVITY CODE

1. E-1371 THRU 1593; CE-816 THRU CE-883; CJ-150 THRU CJ-155; D-10179 THRU D-10302; EA-1 THRU EA-32

Beechcraft
BONANZA
WIRING DIAGRAM MANUAL

28-40-03

**E-1594 THRU E-1835; CE-884 THRU CE-946; D-10303 THRU D-10369;
EA-33 THRU EA-212**

Beechcraft BONANZA WIRING DIAGRAM MANUAL

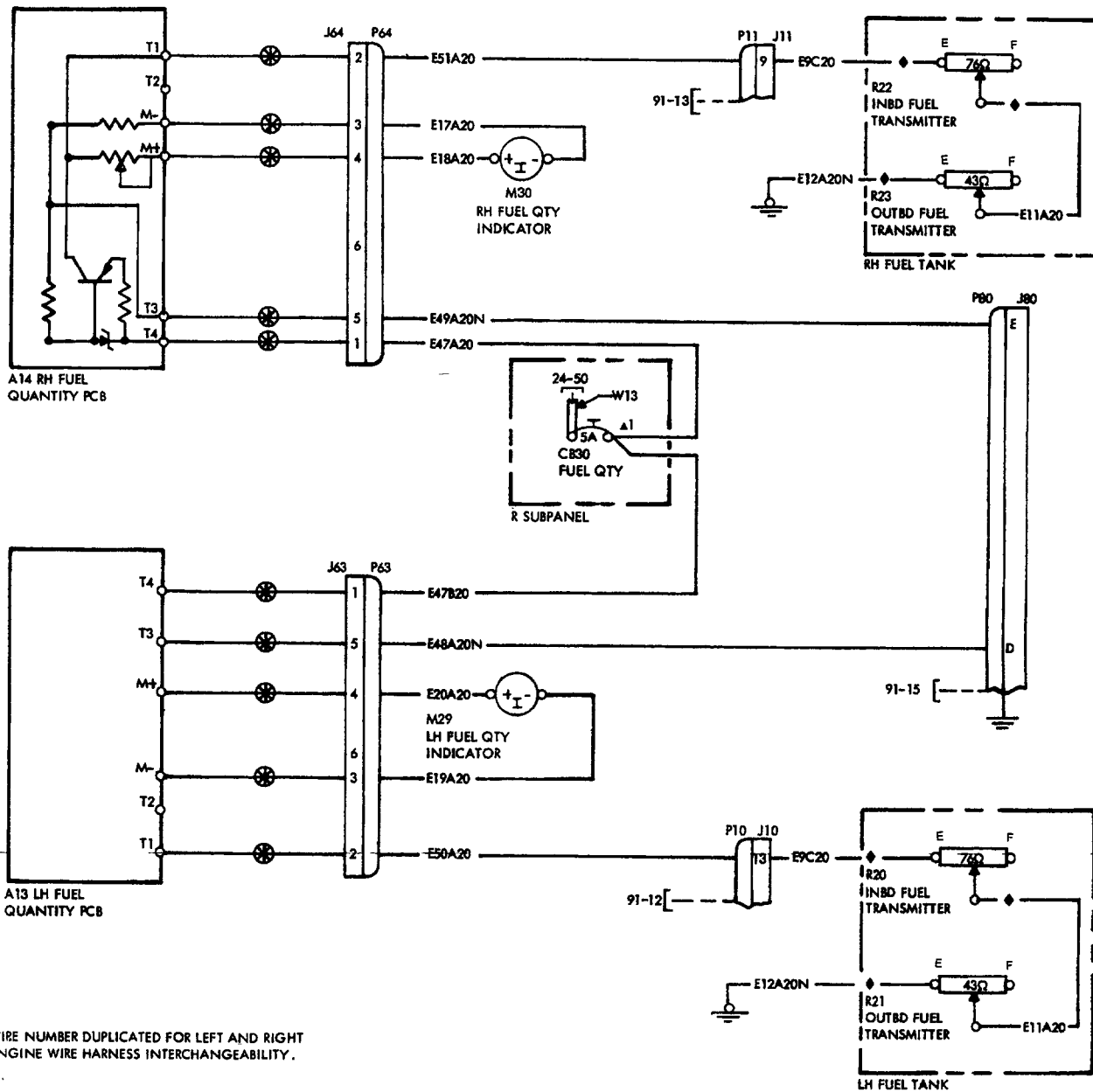

◆ WIRE NUMBER DUPLICATED FOR LEFT AND RIGHT ENGINE WIRE HARNESS INTERCHANGEABILITY.

INDICATING-FUEL QUANTITY

Beechcraft
BONANZA
WIRING DIAGRAM MANUAL

REFERENCE DESIGNATOR	PART NUMBER	DESCRIPTION	USABLE	
			INSTL ZONE	ON CODE
28-40-03				
A13	58-364041-9	PRINTED CIRCUIT BOARD-FUEL QUANTITY,LEFT	240	1
A14	58-364041-9	PRINTED CIRCUIT BOARD-FUEL QUANTITY,RIGHT	240	1
CB30	435-205-104	CIRCUIT BREAKER-FUEL QUANTITY	240	2
CB30	7277-2-5	CIRCUIT BREAKER-FUEL QUANTITY	240	3
J10A	206036-3	RECEPTACLE-LEFT WHEEL WELL ACCESS	532	1
J10B	206070-1	STRAIN RELIEF	532	1
J10C	66103-2	PIN CONTACT	532	1
J10D	66099-2	PIN CONTACT	532	1
J11A	206036-3	RECEPTACLE-WHEEL WELL ACCESS, RIGHT	632	1
J11B	206070-1	STRAIN RELIEF	632	1
J11C	66099-2	PIN CONTACT	632	1
J11D	66103-2	PIN CONTACT	632	1
J63A	1-480340-0	RECEPTACLE-LEFT FUEL QUANTITY PRINTED CIRCUIT BOARD	240	1
J63B	60618-1	PIN CONTACT	240	1
J64A	1-480340-0	RECEPTACLE-RIGHT FUEL QUANTITY PRINTED CIRCUIT BOARD	240	1
J64B	60618-1	PIN CONTACT	240	1
J80	204814-1	RECEPTACLE-GROUNDING BLOCK	231	1
M29	58-380051	INDICATOR-LEFT FUEL QUANTITY	240	1
M30	58-380051	INDICATOR-RIGHT FUEL QUANTITY	240	1
P10A	206037-1	PLUG-LEFT WHEEL WELL ACCESS	532	1
P10B	66101-2	SOCKET CONTACT	532	1
P10C	66105-2	SOCKET CONTACT	532	1
P10D	206070-1	STRAIN RELIEF CLAMP	532	1
P11A	206037-1	PLUG-WHEEL WELL ACCESS, RIGHT	632	1
P11B	206070-1	STRAIN RELIEF	632	1
P11C	66101-2	SOCKET CONTACT	632	1
P11D	66105-2	SOCKET CONTACT	632	1
P63A	1-480270-0	PLUG-LEFT FUEL QUANTITY PRINTED CIRCUIT BOARD	240	1
P63B	60617-1	SOCKET CONTACT	240	1
P64A	1-480270-0	PLUG-RIGHT FUEL QUANTITY PRINTED CIRCUIT BOARD	240	1
P64B	60617-1	SOCKET CONTACT	240	1
P80A	200838-3	PLUG-GROUNDING BLOCK	231	1
P80B	201224-1	STRAIN RELIEF	231	1
P80C	201328-1	SOCKET CONTACT	231	1
P80D	200333-1	SOCKET CONTACT	231	1
P80E	203618-1	JACKSCREW	231	1
R20	96-380041-1	TRANSMITTER-LEFT INBOARD FUEL, SENSOR	531	1
R21	96-380042-1	TRANSMITTER-LEFT OUTBOARD FUEL, SENSOR	631	1
R22	96-380041-1	TRANSMITTER-RIGHT INBOARD FUEL, SENSOR	531	1
R23	96-380042-3	TRANSMITTER-RIGHT OUTBOARD FUEL, SENSOR	631	1

Beechcraft BONANZA WIRING DIAGRAM MANUAL

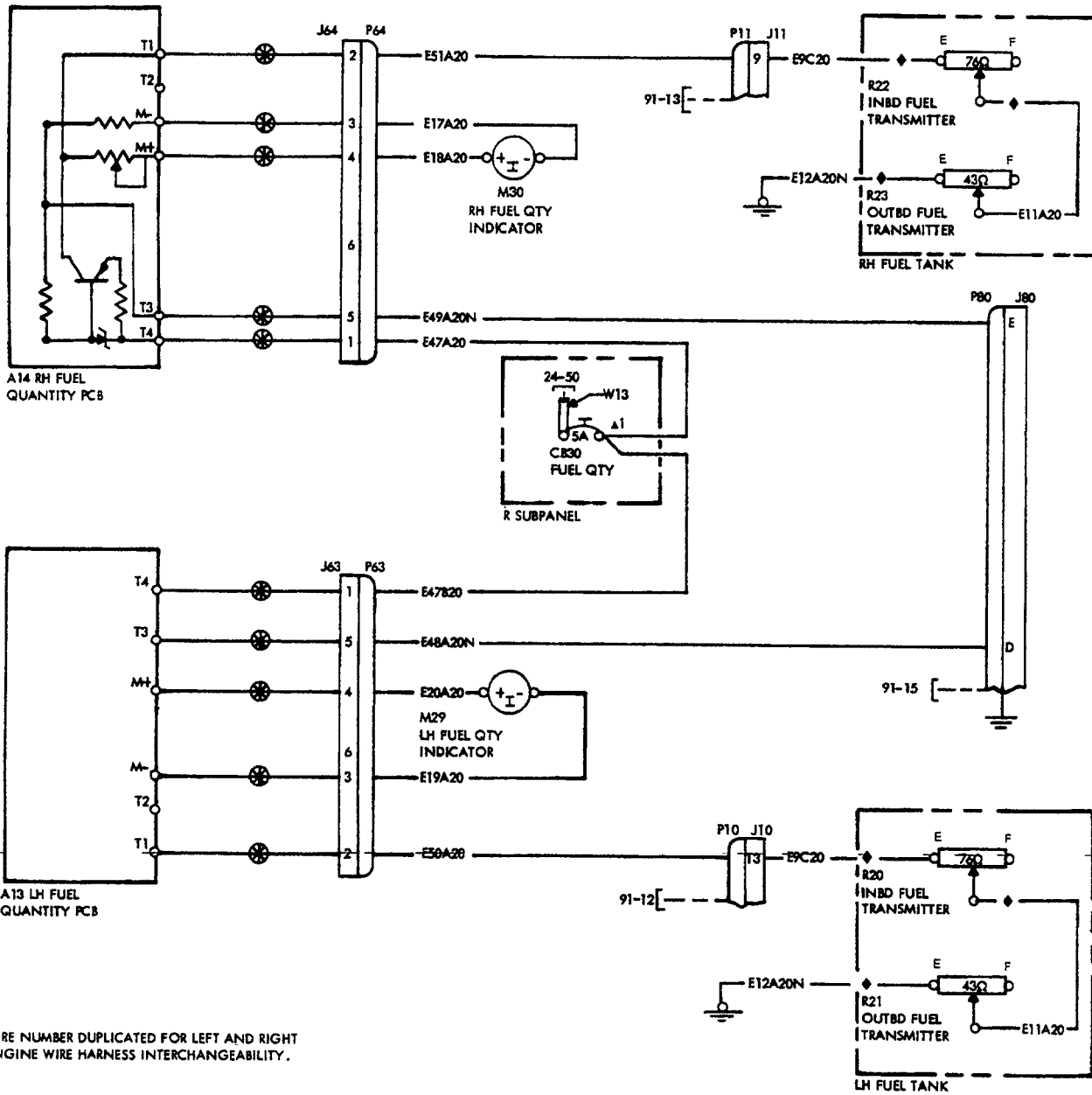

◆ WIRE NUMBER DUPLICATED FOR LEFT AND RIGHT ENGINE WIRE HARNESS INTERCHANGEABILITY.

INDICATING-FUEL QUANTITY

Beechcraft
BONANZA
WIRING DIAGRAM MANUAL

REFERENCE DESIGNATOR	PART NUMBER	DESCRIPTION	USABLE INSTL ON ZONE CODE
		28-40-03	
W13	114931-1-12	BUS-MAIN	240 1

EFFECTIVITY CODE

1. E-1594 THRU E-1835; CE-884 THRU CE-946; D-10303 THRU D-10369; EA-33 THRU EA-212
2. E-1594 THRU E-1765; CE-884 THRU CE-918, CE-920 THRU CE-928; D-10303 THRU D-10347, D-10349 THRU D-10353; EA-33 THRU EA-158
3. E-1766 THRU E-1835; CE-919, CE-929 THRU CE-946; D-10348, D-10354 THRU D-10369; EA-159 THRU EA-212

Beechcraft
BONANZA
WIRING DIAGRAM MANUAL

28-40-04

**E-1836 THRU E-1945, E-1947 THRU E-2103, E-2105 THRU E-2110;
CE-947 AND AFTER; CJ-156 AND AFTER; D-10370 AND AFTER;
EA-213 THRU EA-241, EA-243 THRU EA-272**

Beechcraft BONANZA WIRING DIAGRAM MANUAL

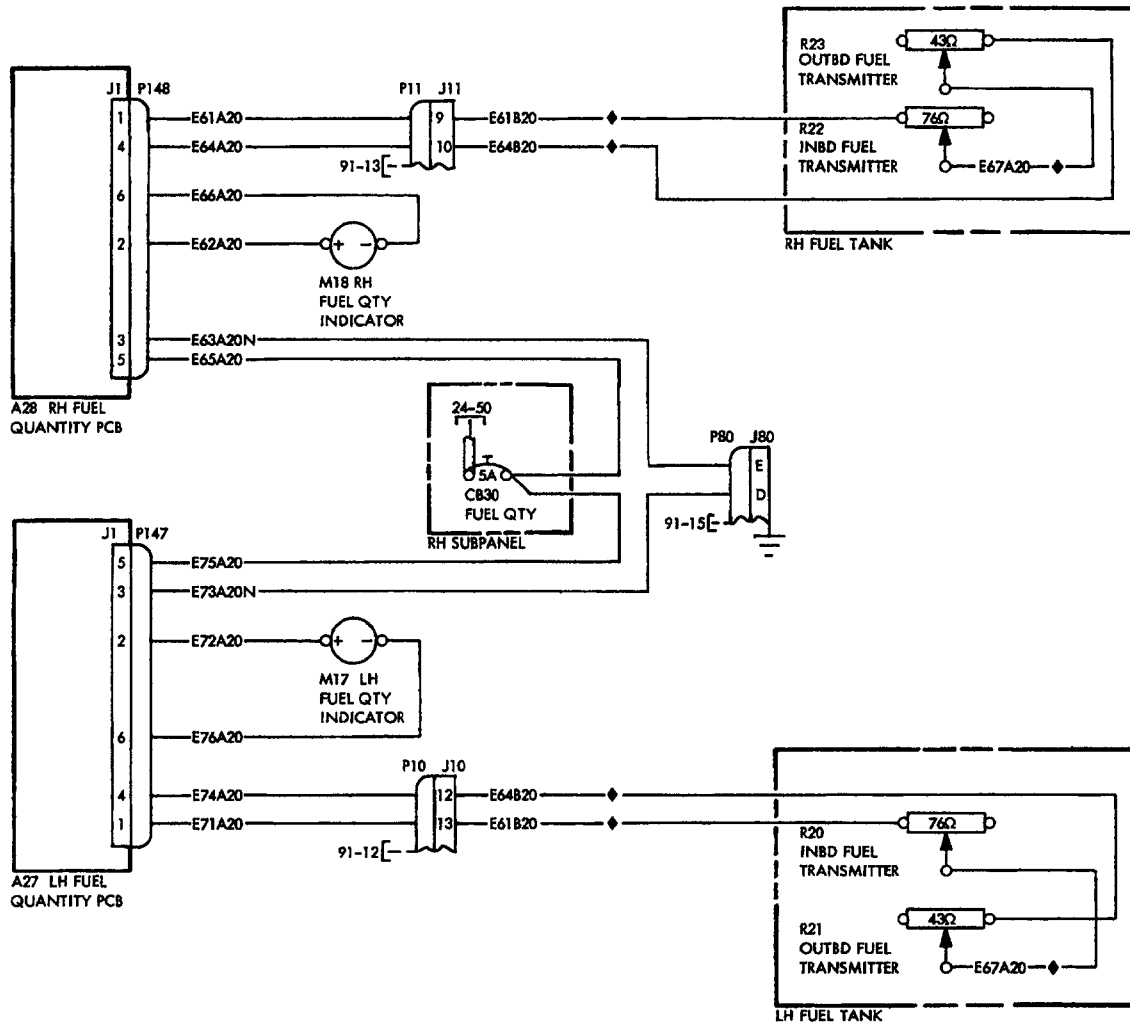

◆ WIRE NUMBER DUPLICATED FOR LEFT AND RIGHT ENGINE WIRE HARNESS INTERCHANGEABILITY.

INDICATING-FUEL QUANTITY

Beechcraft
BONANZA
WIRING DIAGRAM MANUAL

REFERENCE DESIGNATOR	PART NUMBER	DESCRIPTION	USABLE	
			INSTL ZONE	ON CODE
28-40-04				
A27	58-364058-3	PRINTED CIRCUIT BOARD-LEFT FUEL QUANTITY	240	2
A27	58-364058-13	PRINTED CIRCUIT BOARD-LEFT FUEL QUANTITY	240	3
A27J1	207378-1	RECEPTACLE-LEFT FUEL QUANTITY	240	1
A28	58-364058-3	PRINTED CIRCUIT BOARD-RIGHT FUEL QUANTITY	240	2
A28	58-364058-13	PRINTED CIRCUIT BOARD-RIGHT FUEL QUANTITY	240	3
A28J1	207378-1	RECEPTACLE-RIGHT FUEL QUANTITY	240	1
CB30	7277-2-5	CIRCUIT BREAKER-FUEL QUANTITY	240	1
J10A	206036-3	RECEPTACLE-LEFT WHEEL WELL ACCESS	532	1
J10B	206070-1	STRAIN RELIEF	532	1
J10C	66103-2	PIN CONTACT	532	1
J10D	66099-2	PIN CONTACT	532	1
J11A	206036-3	RECEPTACLE-WHEEL WELL ACCESS, RIGHT	632	1
J11B	206070-1	STRAIN RELIEF	632	1
J11C	66099-2	PIN CONTACT	632	1
J11D	66103-2	PIN CONTACT	632	1
J80	204814-1	RECEPTACLE-GROUNDING BLOCK	231	1
P10A	206037-1	PLUG-LEFT WHEEL WELL ACCESS	532	1
P10B	66101-2	SOCKET CONTACT	532	1
P10C	66105-2	SOCKET CONTACT	532	1
P10D	206070-1	STRAIN RELIEF CLAMP	532	1
P11A	206037-1	PLUG-WHEEL WELL ACCESS, RIGHT	632	1
P11B	206070-1	STRAIN RELIEF	632	1
P11C	66101-2	SOCKET CONTACT	632	1
P11D	66105-2	SOCKET CONTACT	632	1
P147A	207377-1	PLUG-LEFT FUEL QUANTITY	240	1
P147B	66105-2	SOCKET CONTACT	240	1
P148A	207377-1	PLUG-RIGHT FUEL QUANTITY	240	1
P148B	66105-2	SOCKET CONTACT	240	1
P80A	200838-3	PLUG-GROUNDING BLOCK	231	1
P80B	201224-1	STRAIN RELIEF	231	1
P80C	201328-1	SOCKET CONTACT	231	1
P80D	200333-1	SOCKET CONTACT	231	1
P80E	203618-1	JACKSCREW	231	1
R20	96-380041-1	TRANSMITTER-LEFT INBOARD FUEL, SENSOR	531	1
R21	96-380042-1	TRANSMITTER-LEFT OUTBOARD FUEL, SENSOR	631	1
R22	96-380041-1	TRANSMITTER-RIGHT INBOARD FUEL, SENSOR	531	1
R23	96-380042-3	TRANSMITTER-RIGHT OUTBOARD FUEL, SENSOR	631	1

EFFECTIVITY CODE

1. E-1836 THRU E-1945, E-1947 THRU E-2103, E-2105 THRU E-2110; CE-947 AND AFTER; CJ-156 AND AFTER; D-10370 AND AFTER; EA-213 THRU EA-241, EA-243 THRU EA-272

2. E-1836 THRU E-1945, E-1947 THRU E-2103, E-2105 THRU E-2110; CE-947 THRU CE-1009; CJ-156 AND AFTER; D-10370 AND AFTER; EA-213 THRU EA-241, EA-243 THRU EA-272

3. CE-1010 AND AFTER

Beechcraft
BONANZA
WIRING DIAGRAM MANUAL

28-40-05

E-242, EA-273 THRU EA-319, EA-321 THRU EA-388

Beechcraft BONANZA WIRING DIAGRAM MANUAL

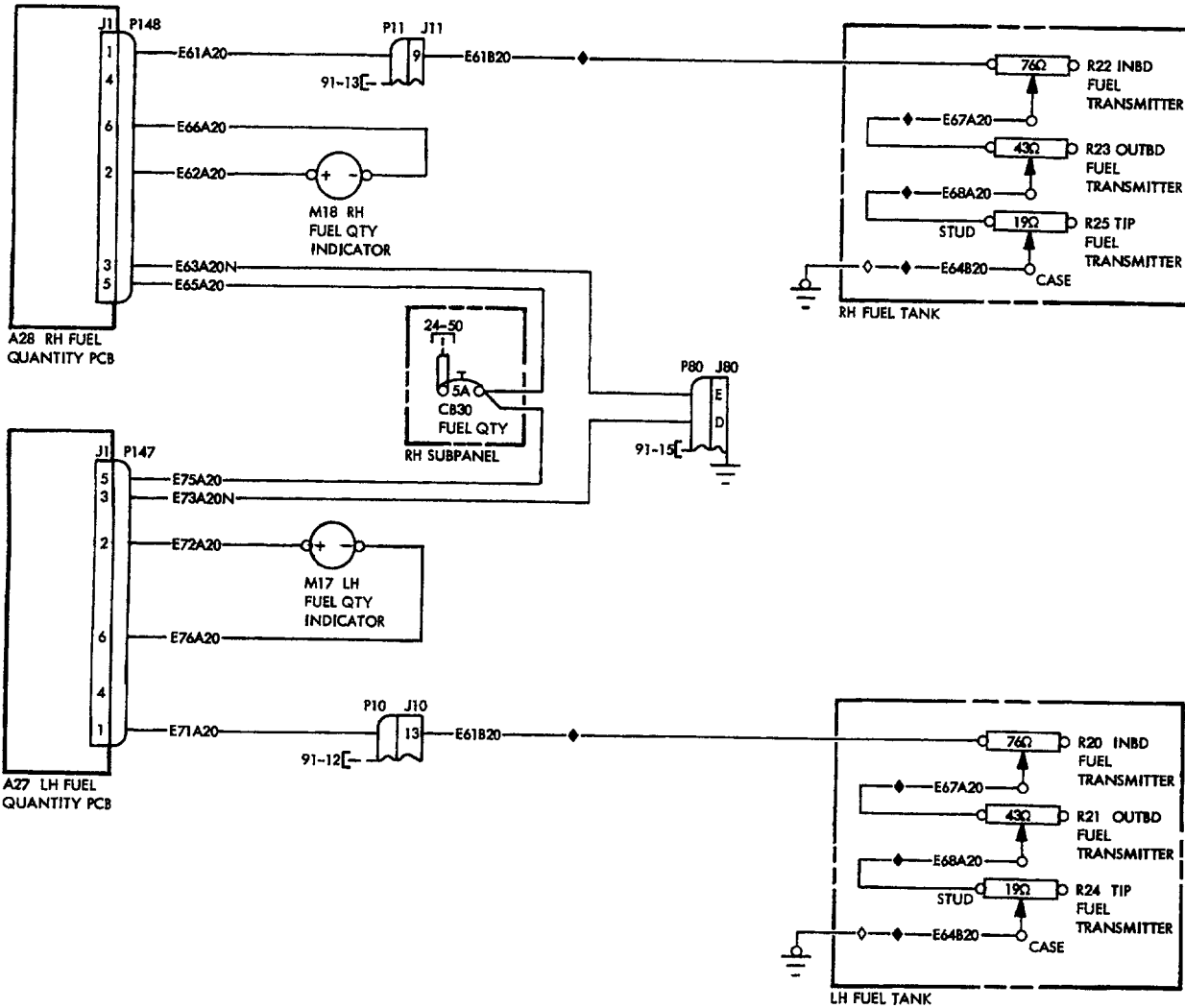

- ◇ IT IS PERMISSIBLE TO USE BONDING JUMPER.
- ◆ WIRE NUMBER DUPLICATED FOR LEFT AND RIGHT ENGINE WIRE HARNESS INTERCHANGEABILITY.

INDICATING-FUEL QUANTITY

Beechcraft BONANZA WIRING DIAGRAM MANUAL

REFERENCE DESIGNATOR	PART NUMBER	DESCRIPTION	INSTL	USABLE ON ZONE CODE
28-40-05				
A27	58-364058-13	PRINTED CIRCUIT BOARD-LEFT FUEL QUANTITY	240	1
A27J1	207378-1	RECEPTACLE-LEFT FUEL QUANTITY	240	1
A28	58-364058-3	PRINTED CIRCUIT BOARD-RIGHT FUEL QUANTITY	240	1
A28J1	207378-1	RECEPTACLE-RIGHT FUEL QUANTITY	240	1
CB30	7277-2-5	CIRCUIT BREAKER-FUEL QUANTITY	240	1
J10A	206036-3	RECEPTACLE-LEFT WHEEL WELL ACCESS	532	1
J10B	206070-1	STRAIN RELIEF	532	1
J10C	66103-2	PIN CONTACT	532	1
J10D	66099-2	PIN CONTACT	532	1
J11A	206036-3	RECEPTACLE-WHEEL WELL ACCESS, RIGHT	632	1
J11B	206070-1	STRAIN RELIEF	632	1
J11C	66099-2	PIN CONTACT	632	1
J11D	66103-2	PIN CONTACT	632	1
J80	204814-1	RECEPTACLE-GROUNDING BLOCK	231	1
M17	58-380050-19	INDICATOR-FUEL QUANTITY, UNLIT, USED WITH POST LIGHTS (ALTN FOR 58-380074-17)	240	1
M17	58-380074-17	INDICATOR-FUEL QUANTITY, UNLIT, USED WITH POST LIGHTS (ALTN FOR 58-380050-19)	240	1
M17	58-380051-17	INDICATOR-FUEL QUANTITY, LIGHTED (OPTL) (ALTN FOR 58-380075-17)	240	1
M17	58-380075-17	INDICATOR-FUEL QUANTITY, LIGHTED (OPTL) (ALTN FOR 58-380051-17)	240	1
M18	58-380050-19	INDICATOR-FUEL QUANTITY, UNLIT, USED WITH POST LIGHTS (ALTN FOR 58-380074-17)	240	1
M18	58-380074-17	INDICATOR-FUEL QUANTITY, UNLIT, USED WITH POST LIGHTS (ALTN FOR 58-380050-19)	240	1
M18	58-380051-17	INDICATOR-FUEL QUANTITY, LIGHTED (OPTL) (ALTN FOR 58-380075-17)	240	1
M18	58-380075-17	INDICATOR-FUEL QUANTITY, LIGHTED (OPTL) (ALTN FOR 58-380051-17)	240	1
P10A	206037-1	PLUG-LEFT WHEEL WELL ACCESS	532	1
P10B	66101-2	SOCKET CONTACT	532	1
P10C	66105-2	SOCKET CONTACT	532	1
P10D	206070-1	STRAIN RELIEF CLAMP	532	1
P11A	206037-1	PLUG-WHEEL WELL ACCESS, RIGHT	632	1
P11B	206070-1	STRAIN RELIEF	632	1
P11C	66101-2	SOCKET CONTACT	632	1
P11D	66105-2	SOCKET CONTACT	632	1
P147A	207377-1	PLUG-LEFT FUEL QUANTITY	240	1
P147B	66105-2	SOCKET CONTACT	240	1
P148A	207377-1	PLUG-RIGHT FUEL QUANTITY	240	1
P148B	66105-2	SOCKET CONTACT	240	1
P80A	200838-3	PLUG-GROUNDING BLOCK	231	1
P80B	201224-1	STRAIN RELIEF	231	1
P80C	201328-1	SOCKET CONTACT	231	1
P80D	200333-1	SOCKET CONTACT	231	1
P80E	203618-1	JACKSCREW	231	1
R20	96-380041-1	TRANSMITTER-LEFT INBOARD FUEL, SENSOR	531	1
R21	96-380042-1	TRANSMITTER-LEFT OUTBOARD FUEL, SENSOR	631	1
R22	96-380041-1	TRANSMITTER-RIGHT INBOARD FUEL, SENSOR	531	1

Beechcraft BONANZA WIRING DIAGRAM MANUAL

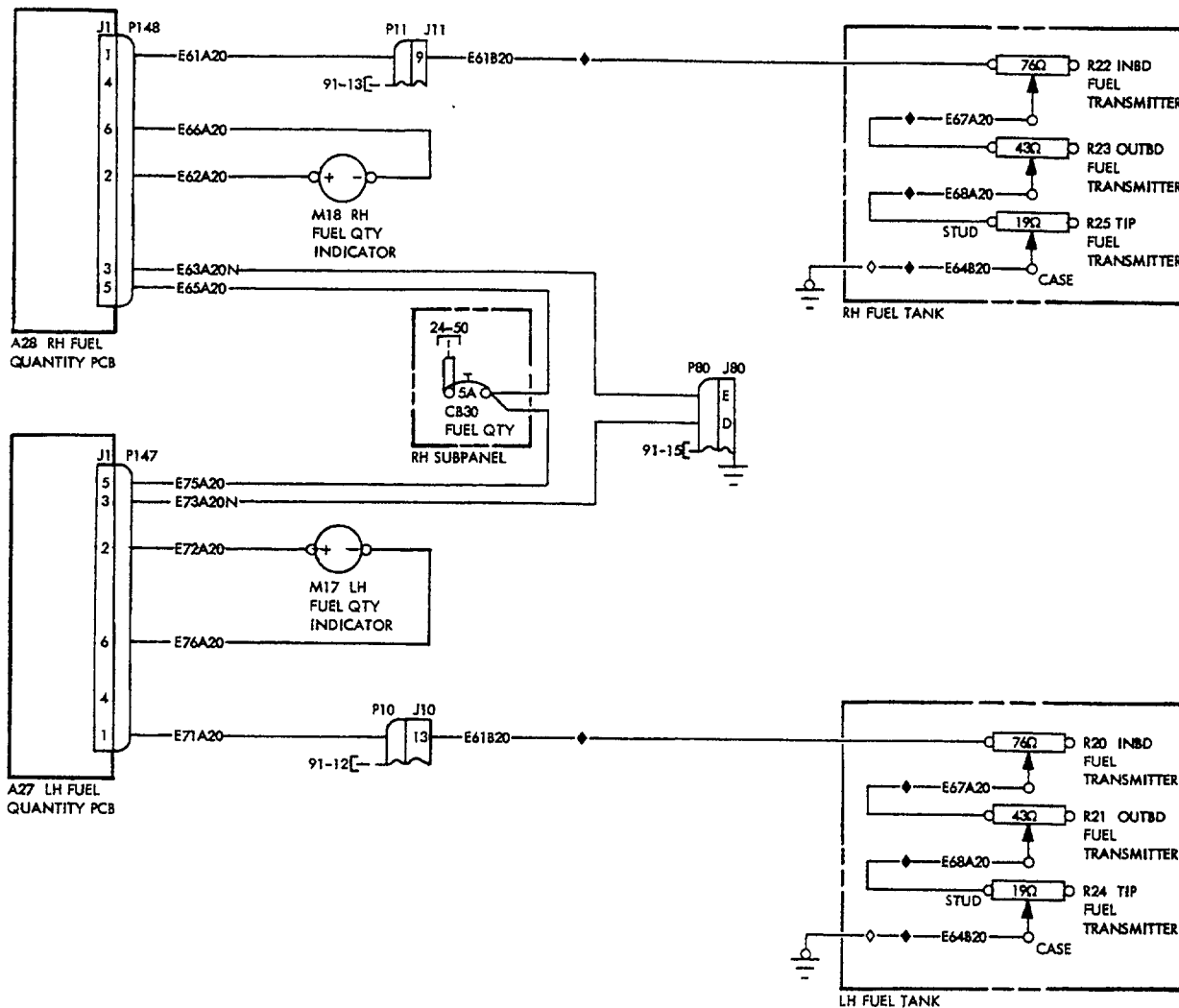

- ◇ IT IS PERMISSIBLE TO USE BONDING JUMPER.
- ◆ WIRE NUMBER DUPLICATED FOR LEFT AND RIGHT ENGINE WIRE HARNESS INTERCHANGEABILITY.

INDICATING-FUEL QUANTITY

Beechcraft
BONANZA
WIRING DIAGRAM MANUAL

REFERENCE DESIGNATOR	PART NUMBER	DESCRIPTION	USABLE	
			INSTL ZONE	ON CODE
28-40-05				
R23	96-380042-3	TRANSMITTER-RIGHT OUTBOARD FUEL, SENSOR	631	1
R24	002-381000-1	TRANSMITTER-LEFT TIP FUEL	542	1
R25	002-381000-3	TRANSMITTER-RIGHT TIP FUEL	642	1

EFFECTIVITY CODE

1. EA-242, EA-273 THRU EA-319, EA-321 THRU EA-388

CHAPTER

30

**ICE AND RAIN
PROTECTION**

Beechcraft
BONANZA
WIRING DIAGRAM MANUAL
LIST OF PAGES & TABLE OF CONTENTS
for
CHAPTER 30 - ICE AND RAIN PROTECTION

SYS/SUB-SYS/ CHAP SECTION	PAGE NO.	EFFECTIVE DATE	TABLE OF CONTENTS
30-30-01	Page 1	OCT/95	PITOT-HEATED (OPTIONAL)
	Page 2	OCT/95	
	Page 3	OCT/95	
30-30-02	Page 1	OCT/95	PITOT-HEATED (OPTIONAL)
	Page 2	OCT/95	
	Page 3	OCT/95	
30-60-01 (Config 1)	Page 1	OCT/95	PROPELLERS ANTI-ICE (OPTIONAL)
	Page 2	OCT/95	
	Page 3	OCT/95	
30-60-01 (Config 2)	Page 1	OCT/95	PROPELLERS ANTI-ICE (OPTIONAL)
	Page 2	OCT/95	
	Page 3	OCT/95	

Beechcraft
BONANZA
WIRING DIAGRAM MANUAL

30-30-01

**E-1111, E-1241 THRU E-1370; CE-748, CE-772 THRU CE-815; CJ-149
ONLY; D-10097, D-10120 THRU D-10178**

Beechcraft
BONANZA
WIRING DIAGRAM MANUAL

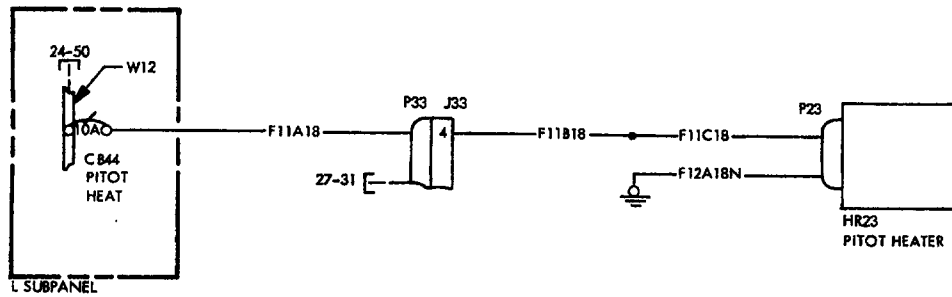

PITOT-HEATED (OPTIONAL)

Beechcraft
BONANZA
WIRING DIAGRAM MANUAL

REFERENCE DESIGNATOR	PART NUMBER	DESCRIPTION	USABLE	
			INSTL ZONE	ON CODE
30-30-01				
CB44	35-380132-3	CIRCUIT BREAKER-PITOT HEAT	240	1
HR23	50-384040-1	HEATER-PITOT (OPTL)	511	1
J33A	206153-1	RECEPTACLE-STALL WARNING HORN	532	1
J33B	206062-1	STRAIN RELIEF	532	1
J33C	66099-2	SOCKET CONTACT	532	1
J33D	66103-2	SOCKET CONTACT	532	1
P23	AN3115-1	PLUG-PITOT HEATER (OPTL)	531	1
P33A	206060-1	PLUG-STALL WARNING HORN	532	1
P33B	206062-1	STRAIN RELIEF	532	1
P33C	66101-2	SOCKET CONTACT	532	1
P33D	66105-2	SOCKET CONTACT	532	1
W12	114931-1-6	BUS LIGHT	240	1

EFFECTIVITY CODE

1. E-1111, E-1241 THRU E-1370; CE-748, CE-772 THRU CE-815; CJ-149 ONLY; D-10097, D-10120 THRU D-10178

Beechcraft
BONANZA
WIRING DIAGRAM MANUAL

30-30-02

**E-1371 THRU E-1945, E-1947 THRU E-2103, E-2105 THRU E-2110;
CE-816 AND AFTER; CJ-150 AND AFTER; D-10179 AND AFTER; EA-1
THRU EA-319, EA-321 THRU EA-388**

Beechcraft
BONANZA
WIRING DIAGRAM MANUAL

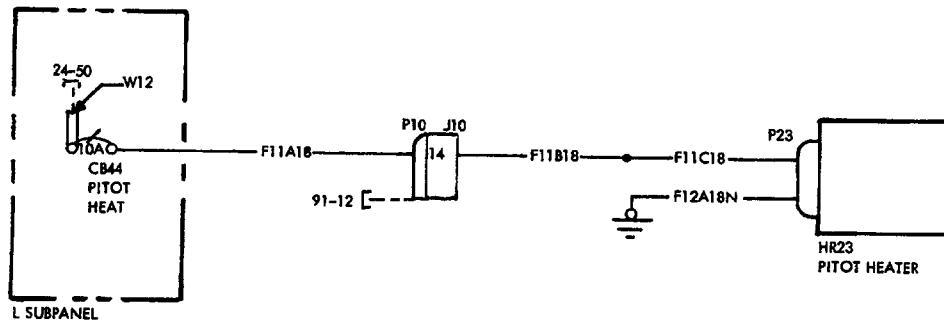

PITOT-HEATED (OPTIONAL)

Beechcraft
BONANZA
WIRING DIAGRAM MANUAL

REFERENCE DESIGNATOR	PART NUMBER	DESCRIPTION	USABLE	
			INSTL ZONE	ON CODE
30-30-02				
CB44	35-380132-3	CIRCUIT BREAKER-PITOT HEAT	240	1
HR23	50-384040-1	HEATER-PITOT (OPTL)	511	1
J10A	206036-3	RECEPTACLE-LEFT WHEEL WELL ACCESS	532	1
J10B	206070-1	STRAIN RELIEF	532	1
J10C	66103-2	PIN CONTACT	532	1
J10D	66099-2	PIN CONTACT	532	1
P10A	206037-1	PLUG-LEFT WHEEL WELL ACCESS	532	1
P10B	66101-2	SOCKET CONTACT	532	1
P10C	66105-2	SOCKET CONTACT	532	1
P10D	206070-1	STRAIN RELIEF CLAMP	532	1
P23	AN3115-1	PLUG-PITOT HEATER (OPTL)	531	1
W12	114931-1-6	BUS LIGHT	240	1

EFFECTIVITY CODE

1. E-1371 THRU E-1945, E-1947 THRU E-2103, E-2105 THRU E-2110; CE-816 AND AFTER; CJ-150 AND AFTER; D-10179 AND AFTER; EA-1 THRU EA-319, EA-321 THRU EA-388

Beechcraft
BONANZA
WIRING DIAGRAM MANUAL

30-60-01

Configuration 1

**E-1255, E-1288 THRU E-1945, E-1947 THRU E-2095; CE-789 THRU
CE-1023; CJ-151 AND AFTER; D-10144 THRU D-10403; EA-1 THRU
EA-319, EA-321 THRU EA-377**

Beechcraft BONANZA WIRING DIAGRAM MANUAL

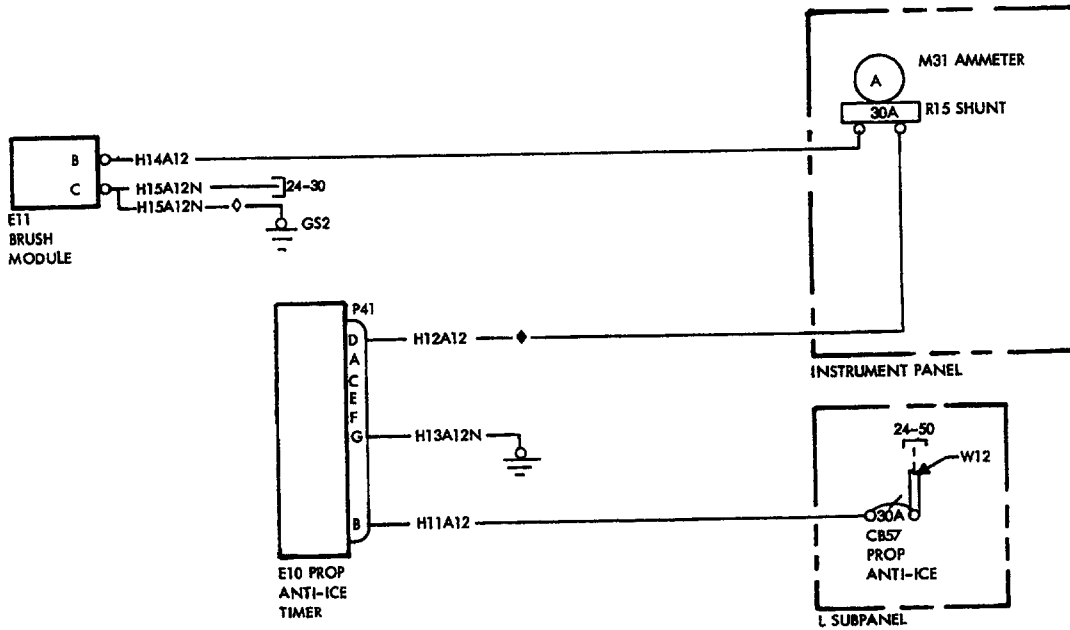

◇ GROUND WIRE TO GS2 STUD
E-1255, E-1258 THRU E-1765;
EA-1 THRU EA-158; CE-789
THRU CE-928; CJ-151 THRU
CJ-155; D-10144 THRU D-10353.

◆ ON AIRCRAFT E-1258 THRU E-1287
AND EA-1, WIRE H12A TERMINATES
AT PIN C.

PROPELLERS ANTI-ICE (OPTIONAL) (Configuration 1)

Beechcraft
BONANZA
WIRING DIAGRAM MANUAL

REFERENCE DESIGNATOR	PART NUMBER	DESCRIPTION	USABLE	
			INSTL ZONE	ON CODE
30-60-01 (Configuration 1)				
CB57	35-380132-9	CIRCUIT BREAKER-PROPELLER ANTI-ICE (OPTL)	240	1
E10	3E1964-3	TIMER-PROPELLER ANTI-ICE (OPTL)	232	1
E11	3E2062	BRUSH MODULE (OPTL)	410	1
GS2	131270-3	GROUND STUD-FIREWALL	221	1
M31	90-380007-5	AMMETER, UNLIGHTED (USED WITH 2-BLADE PROPELLER)	240	1
M31	90-380007-7	AMMETER, LIGHTED (USED WITH 2-BLADE PROPELLER)	240	1
M31	90-380007-9	AMMETER, UNLIGHTED (USED WITH 3-BLADE PROPELLER)	240	1
M31	90-380007-11	AMMETER, LIGHTED (USED WITH 3-BLADE PROPELLER)	240	1
P41	132325 20-15S	PLUG-PROPELLER ANTI-ICE TIMER (OPTL) (ALTN FOR MS3106R20-15S)	240	1
P41	MS3106R20-15S	PLUG-PROPELLER ANTI-ICE TIMER (OPTL) (ALTN FOR 132325 20-15S)	240	1
R15	90-380008-1	SHUNT-PROPELLER ANTI-ICE (OPTL)	240	1
W12	114931-1-6	BUS LIGHT	240	1

EFFECTIVITY CODE

1. E-1255, E-1288 THRU E-1945, E-1947 THRU E-2095; CE-789 THRU CE-1023; CJ-151 AND AFTER; D-10144 THRU D-10403; EA-1 THRU EA-319, EA-321 THRU EA-377

Beechcraft
BONANZA
WIRING DIAGRAM MANUAL

30-60-01

Configuration 2

**E-2096 THRU E-2103, E-2105 THRU E-2110; CE-1024 AND AFTER;
D-10404 AND AFTER; EA-378 THRU EA-388**

Beechcraft BONANZA WIRING DIAGRAM MANUAL

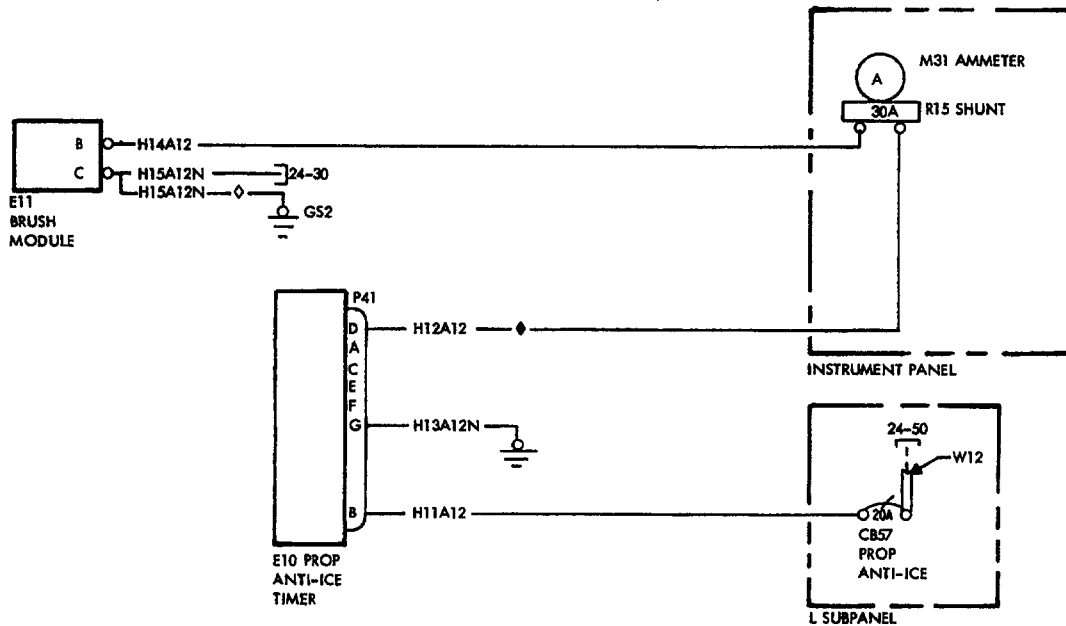

- ◇ GROUND WIRE TO GS2 STUD
E-1255, E-1258 THRU E-1765;
EA-1 THRU EA-158; CE-789
THRU CE-928; CJ-151 THRU
CJ-155; D-10144 THRU D-10353.
- ◆ ON AIRCRAFT E-1258 THRU E-1287
AND EA-1, WIRE H12A TERMINATES
AT PIN C.

PROPELLERS ANTI-ICE (OPTIONAL) (Configuration 2)

Beechcraft
BONANZA
WIRING DIAGRAM MANUAL

REFERENCE DESIGNATOR	PART NUMBER	DESCRIPTION	USABLE INSTL ON ZONE CODE
30-60-01 (Configuration 2)			
CB57	35-380132-9	CIRCUIT BREAKER-PROPELLER ANTI-ICE (OPTL)	240 1
E10	3E1964-3	TIMER-PROPELLER ANTI-ICE (OPTL)	232 1
E11	3E2062	BRUSH MODULE (OPTL)	410 1
GS2	131270-3	GROUND STUD-FIREWALL	221 1
M31	90-380007-5	AMMETER, UNLIGHTED (USED WITH 2-BLADE PROPELLER)	240 1
M31	90-380007-7	AMMETER, LIGHTED (USED WITH 2-BLADE PROPELLER)	240 1
M31	90-380007-9	AMMETER, UNLIGHTED (USED WITH 3-BLADE PROPELLER)	240 1
M31	90-380007-11	AMMETER, LIGHTED (USED WITH 3-BLADE PROPELLER)	240 1
P41	132325 20-15S	PLUG-PROPELLER ANTI-ICE TIMER (OPTL) (ALTN FOR MS3106R20-15S)	240 1
P41	MS3106R20-15S	PLUG-PROPELLER ANTI-ICE TIMER (OPTL) (ALTN FOR 132325 20-15S)	240 1
R15	90-380008-1	SHUNT-PROPELLER ANTI-ICE (OPTL)	240 1
W12	114931-1-6	BUS LIGHT	240 1

EFFECTIVITY CODE

1. E-2096 THRU E-2103, E-2105 THRU E-2110; CE-1024 AND AFTER; D-10404 AND AFTER; EA-378 THRU EA-388

CHAPTER

32

LANDING GEAR

Raytheon Aircraft

BEECH BONANZA WIRING DIAGRAM MANUAL

LIST OF PAGES & TABLE OF CONTENTS for CHAPTER 32 - LANDING GEAR

SYS/SUB-SYS/ CHAP SECTION	PAGE NO.	EFFECTIVE DATE	TABLE OF CONTENTS
32-30-01 (Config 1)	Page 1	Oct/95	LANDING GEAR - MOTOR AND RELAY E-1111, E-1241 THRU E-1910; CE-748, CE-772 THRU CE-968; CJ-149 THRU CJ-179; D-10097, D-10120 THRU D-10379; EA-1 THRU EA-225
	Page 2	Oct/95	
	Page 3	Oct/95	
	Page 4	Oct/95	
	Page 5	Oct/95	
32-30-01 (Config 2)	Page 1	Oct/95	LANDING GEAR - MOTOR AND RELAY CJ-180 AND AFTER
	Page 2	Oct/95	
	Page 3	01/29/99	
32-30-02 (Config 1)	Page 1	Oct/95	LANDING GEAR - MOTOR AND RELAY E-1911 THRU E-1945, E-1947 THRU E-2103, E-2105 THRU E-2110; CE-969 THRU CE-1300, CE-1302 THRU CE-1306; D-10380 AND AFTER; EA-256 THRU EA-319, EA-321 THRU EA-388
	Page 2	Oct/95	
	Page 3	Oct/95	
	Page 4	Oct/95	
	Page 5	Oct/95	
32-30-02 (Config 2)	Page 1	Oct/95	LANDING GEAR - MOTOR AND RELAY CE-1301, CE-1307 AND AFTER
	Page 2	Oct/95	
	Page 3	01/29/99	
32-31-01	Page 1	01/29/99	LANDING GEAR - SAFETY SYSTEM (OPTIONAL) E-1111, E-1241 THRU E-1910; CE-748, CE-772 THRU CE-968; CJ-149 AND AFTER; D-10097, D-10120 THRU D-10379; EA-1 THRU EA-255
	Page 2	01/29/99	
	Page 3	01/29/99	
	Page 4	01/29/99	
	Page 5	01/29/99	
32-31-02	Page 1	01/29/99	LANDING GEAR - SAFETY SYSTEM (OPTIONAL) E-1911 THRU E-1945, E-1947 THRU E-2103, E-2105 THRU E-2110; CE-969 AND AFTER; D-10380 AND AFTER; EA-256 THRU EA-319, EA-321 THRU EA-388
	Page 2	01/29/99	
	Page 3	01/29/99	
	Page 4	01/29/99	
	Page 5	01/29/99	
32-60-01 (Config 1)	Page 1	Oct/95	LANDING GEAR - POSITION INDICATOR E-1111, E-1241 THRU E-1945, E-1947 THRU E-2103, E-2105 THRU E-2110; CE-748, CE-772 THRU CE-1300, CE-1302 THRU CE-1306; CJ-149 THRU CJ-179; D-10097, D-10120 AND AFTER; EA-1 THRU EA-319, EA-321 THRU EA-388
	Page 2	Oct/95	
	Page 3	Oct/95	
	Page 4	Oct/95	
	Page 5	Oct/95	
32-60-01 (Config 2)	Page 1	Oct/95	LANDING GEAR - POSITION INDICATOR CE-1301, CE-1307 AND AFTER; CJ 180 AND AFTER
	Page 2	Oct/95	
	Page 3	Oct/95	
	Page 4	Oct/95	
	Page 5	Oct/95	
32-60-02	Page 1	Oct/95	POSITION AND WARNING - THROTTLE AND AIRSPEED CE-1301, CE-1307 AND AFTER; CJ 180 AND AFTER
	Page 2	Oct/95	
	Page 3	Oct/95	

Beechcraft
BONANZA
WIRING DIAGRAM MANUAL

32-30-01

Configuration 1

**E-1111, E-1241 THRU E-1910; CE-748, CE-772 THRU CE-968; CJ-149
THRU CJ-179; D-10097, D-10120 THRU D-10379; EA-1 THRU EA-225**

Beechcraft
BONANZA
WIRING DIAGRAM MANUAL

REFERENCE DESIGNATOR	PART NUMBER	DESCRIPTION	USABLE	
			INSTL ZONE	ON CODE
32-30-01				
(Configuration 1)				
B21	58-380090-5	MOTOR-LANDING GEAR	150	3
B21	96-380022-5	MOTOR-LANDING GEAR	150	2
CB18	435-205-104	CIRCUIT BREAKER-LANDING GEAR POSITION	240	4
CB18	7277-2-5	CIRCUIT BREAKER-LANDING GEAR POSITION	240	5
CB19	CB2330	CIRCUIT BREAKER-LANDING GEAR	240	4
CB19	MS24510-30	CIRCUIT BREAKER-LANDING GEAR	240	5
CR22	1.5KE51CA	TRANSZORB-DYNAMIC BRAKE	270	1
CR23	1.5KE51CA	TRANSZORB-DYNAMIC BRAKE	270	1
GS1	131270-3	GROUND STUD-MAIN SPAR	270	1
J54A	206152-1	RECEPTACLE-JUNCTION BOX ASSEMBLY	231	6
J54A	206151-2	RECEPTACLE-JUNCTION BOX ASSEMBLY	231	7
J54B	1-205202-6	PIN CONTACT	231	6
J54B	206138-1	STRAIN RELIEF CLAMP	231	7
J54C	206070-1	STRAIN RELIEF CLAMP	231	6
J54C	66103-2	PIN CONTACT	231	7
J56	206036-3	RECEPTACLE-LANDING GEAR LIMIT SWITCH	150	1
J81A	206153-1	RECEPTACLE-LANDING GEAR SAFETY SWITCH, LEFT	532	1
J81B	66099-2	PIN CONTACT	532	1
J82A	206153-1	RECEPTACLE-RIGHT LANDING GEAR SAFETY SWITCH	632	1
J82B	206062-1	STRAIN RELIEF	632	1
J82C	66103-2	PIN CONTACT	632	1
J85A	1-480288-0	RECEPTACLE-CROSSOVER DISCONNECT	251	1
J85B	60618-1	PIN CONTACT	251	1
K17	6046H39A	RELAY-LANDING GEAR DYNAMIC BREAK	150	8
K17	6046H39B	RELAY-LANDING GEAR DYNAMIC BREAK	150	9
P54A	205839-3	PLUG-JUNCTION BOX ASSEMBLY	231	6
P54A	206150-1	PLUG-JUNCTION BOX ASSEMBLY	231	7
P54B	205089-1	SOCKET CONTACT	231	6
P54B	206138-1	STRAIN RELIEF	231	7
P54C	66105-2	SOCKET CONTACT	231	7
P56	1-480283-0	PLUG-LANDING GEAR LIMIT SWITCH	150	1
P81A	206060-1	PLUG-LANDING GEAR SAFETY SWITCH, LEFT	532	1
P81B	660101-2	SOCKET CONTACT	532	1
P82A	206060-2	PLUG HOUSING-LANDING GEAR SAFETY SWITCH, RIGHT	632	1
P82B	66101-2	SOCKET CONTACT	632	1
P85A	1-480287-0	PLUG-CROSSOVER DISCONNECT	251	1
P85B	66017-1	SOCKET CONTACT	251	1
S36	BZ-3AT	SWITCH-LANDING GEAR SAFETY SWITCH, RIGHT	740	1
S37	MS25026-1	SWITCH-LANDING GEAR SAFETY, LEFT	251	1
S38	MS25125-E3	SWITCH-LANDING GEAR (ALTN FOR 8857K44)	240	1
S38	8857K44	SWITCH-LANDING GEAR (ALTN FOR MS25125-E3)	240	1
S39	MS25026-1	SWITCH-LANDING GEAR UPLIMIT	251	1
S40	MS25026-1	SWITCH-LANDING GEAR DOWNLIMIT	251	1

Beechcraft
BONANZA
WIRING DIAGRAM MANUAL

REFERENCE DESIGNATOR	PART NUMBER	DESCRIPTION	USABLE INSTL ON ZONE CODE
		32-30-01 (Configuration 1)	
S45	MS25026-1	SWITCH-LANDING GEAR DOWNLIMIT	251 1

EFFECTIVITY CODE

1. E-1111, E-1241 THRU E-1910; CE-748, CE-772 THRU CE-968; CJ-149 THRU CJ-179; D-10097, D-10120 THRU D-10379; EA-1 THRU EA-255
2. E-1111, E-1241 THRU E-1625; CE-748, CE-772 THRU CE-895; CJ-149 THRU CJ-159; D-10097, D-10120 THRU D-10324; EA-1 THRU EA-48
3. E-1626 THRU E-1910; CE-896 THRU CE-968; CJ-160 THRU CJ-179; D-10325 THRU D-10379; EA-49 THRU EA-255
4. E-1111, E-1241 THRU E-1765; CE-748, CE-772 THRU CE-918, CE-920 THRU CE-928; CJ-149 THRU CJ-155; D-10097, D-10120 THRU D-10347, D-10349 THRU D-10353; EA-1 THRU EA-158
5. E-1766 THRU E-1910; CE-919, CE-929 THRU CE-968; CJ-156 THRU CJ-179; D-10348, D-10354 THRU D-10379; EA-159 THRU EA-255
6. E-1111, E-1241 THRU E-1370; CE-748, CE-772 THRU CE-815; D-10097, D-10120 THRU D-10178; EA-1 ONLY
7. E-1371 THRU E-1910; CE-816 THRU CE-968; D-10179 THRU D-10379; EA-2 THRU EA-255
8. E-1111, E-1241 THRU E-1905; CE-748, CE-772 THRU CE-967; CJ-149 THRU CJ-155; D-10097, D-10120 THRU D-10378; EA-1 THRU EA-253
9. E-1906 THRU E-1910; CE-968 ONLY; CJ-156 THRU CJ-179; D-10379 ONLY; EA-254 AND EA-255

Beechcraft
BONANZA
WIRING DIAGRAM MANUAL

32-30-01

Configuration 2

CJ-180 AND AFTER

Beechcraft BONANZA WIRING DIAGRAM MANUAL

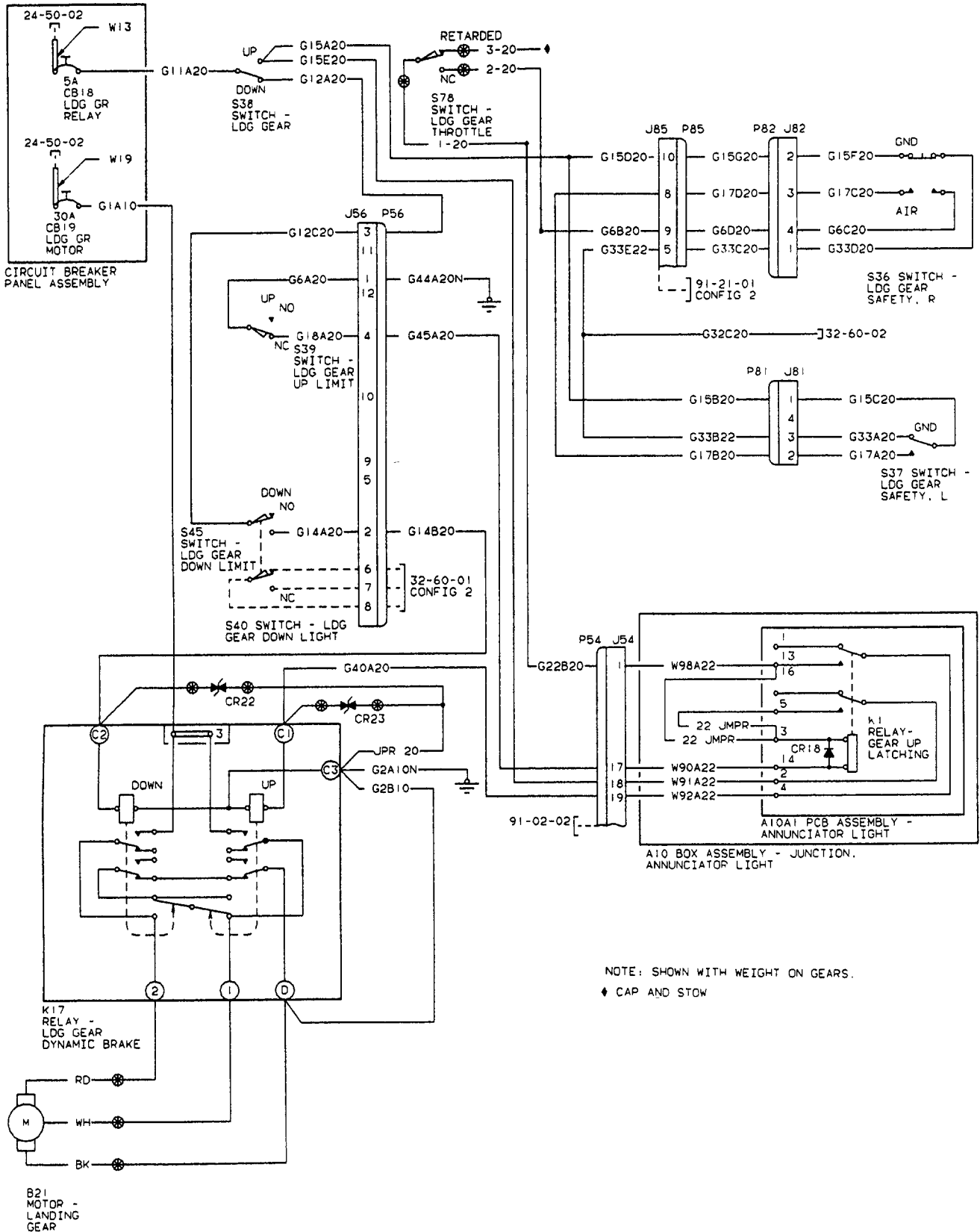

NOTE: SHOWN WITH WEIGHT ON GEARS.

◆ CAP AND STOW

**LANDING GEAR-MOTOR AND RELAY
(Configuration 2)**

Raytheon Aircraft

BEECH BONANZA WIRING DIAGRAM MANUAL

REFERENCE DESIGNATOR	PART NUMBER	DESCRIPTION	INSTL ZONE	USABLE ON CODE
32-30-01				
(Configuration 2)				
A10	58-364056-15	BOX ASSEMBLY-JUNCTION ANNUNCIATOR LIGHT	231	1
A10A1	58-364056-9	PRINTED CIRCUIT BOARD ASSEMBLY-ANNUNCIATOR LIGHT	231	1
A10A1CR18	1N4007	DIODE (SUPERSEDED BY 132408-22)	231	1
A10A1CR18	132408-22	DIODE (SUPERSEDES 1N4007)	231	1
A10A1K1	50-384112-1	RELAY-GEAR UP LATCHING	231	1
B21	58-380090-5	MOTOR-LANDING GEAR	150	1
CB18	7277-2-5	CIRCUIT BREAKER-LANDING GEAR POSITION	240	1
CB19	MS24510-30	CIRCUIT BREAKER-LANDING GEAR	240	1
CR22	1.5KE51CA	TRANSZORB-DYNAMIC BRAKE	270	1
CR23	1.5KE51CA	TRANSZORB-DYNAMIC BRAKE	270	1
J54A	206151-2	RECEPTACLE-JUNCTION BOX ASSEMBLY	231	1
J54B	206138-1	STRAIN CLAMP RELIEF	231	1
J54C	66103-2	PIN CONTACT	231	1
J56A	207018-1	RECEPTACLE-LANDING GEAR LIMIT SWITCH	150	1
J56B	66103-2	PIN CONTACT	150	1
J56C	66602-1	PIN CONTACT	150	1
J81A	206153-1	RECEPTACLE-LANDING GEAR SAFETY SWITCH, LEFT	532	1
J81B	66099-2	PIN CONTACT	532	1
J82A	206153-1	RECEPTACLE-RIGHT LANDING GEAR SAFETY SWITCH	632	1
J82B	206062-1	STRAIN RELIEF	632	1
J82C	66103-2	PIN CONTACT	632	1
J85A	1-480288-0	RECEPTACLE-CROSSOVER DISCONNECT	251	1
J85B	60618-1	PIN CONTACT	251	1
K17	6046H39B	RELAY-LANDING GEAR DYNAMIC BREAK	150	1
P54A	206150-1	PLUG-JUNCTION BOX ASSEMBLY	231	1
P54B	206138-1	STRAIN RELIEF	231	1
P54C	66105-2	SOCKET CONTACT	231	1
P56A	207017-1	PLUG-LANDING GEAR LIMIT SWITCH	150	1
P56B	66105-2	SOCKET CONTACT	150	1
P81A	206060-1	PLUG-LANDING GEAR SAFETY SWITCH, LEFT	532	1
P81B	660101-2	SOCKET CONTACT	532	1
P82A	206060-2	PLUG HOUSING-LANDING GEAR SAFETY SWITCH, RIGHT	632	1
P82B	66101-2	SOCKET CONTACT	632	1
P85A	1-480287-0	PLUG-CROSSOVER DISCONNECT	251	1
P85B	66017-1	SOCKET CONTACT	251	1
S36	BZ-3AT	SWITCH-LANDING GEAR SAFETY, RIGHT	740	1
S37	MS25026-1	SWITCH-LANDING GEAR SAFETY, LEFT	251	1
S38	MS25125-E3	SWITCH-LANDING GEAR (ALTN FOR 8857K44)	240	1
S38	8857K44	SWITCH-LANDING GEAR (ALTN FOR MS25125-E3)	240	1
S39	MS25008-1	SWITCH-LANDING GEAR UPLIMIT	251	1
S40	MS25026-1	SWITCH-LANDING GEAR DOWNLIMIT	251	1
S45	MS25026-1	SWITCH-LANDING GEAR DOWNLIMIT	251	1
S78	A5-103-1031	THROTTLE, LANDING GEAR	410	1
W13	114931-12	BUS-MAIN	240	1
W19	114931-10	BUS-SECONDARY	240	1

CODES OF EFFECTIVITY

1. CJ-180 AND AFTER

Beechcraft BONANZA WIRING DIAGRAM MANUAL

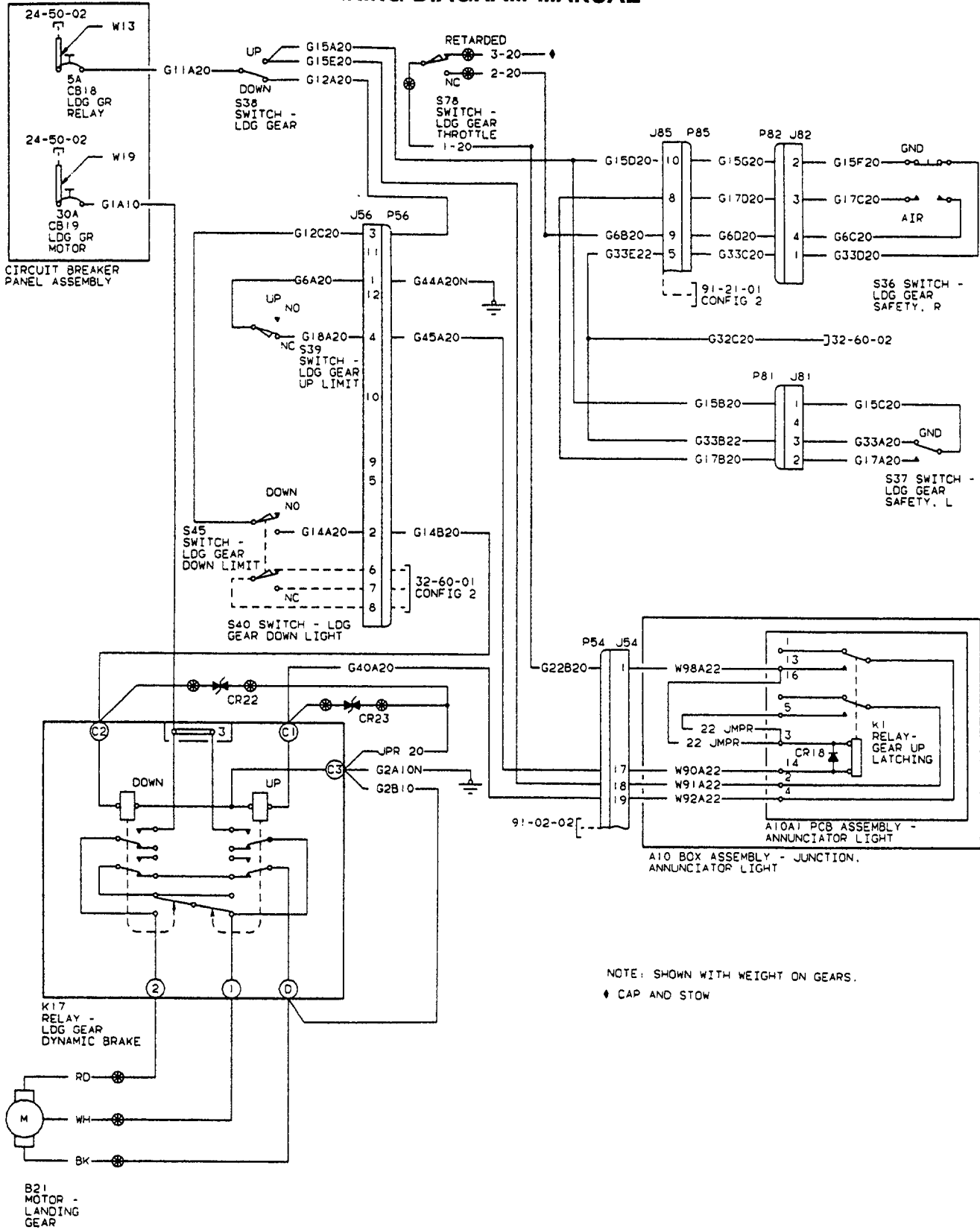

NOTE: SHOWN WITH WEIGHT ON GEARS.
♦ CAP AND STOW

**LANDING GEAR-MOTOR AND RELAY
(Configuration 2)**

Beechcraft
BONANZA
WIRING DIAGRAM MANUAL

REFERENCE DESIGNATOR	PART NUMBER	DESCRIPTION	USABLE	
			INSTL ZONE	ON CODE
		32-30-01 (Configuration 2)		
W19	114931-10	BUS-SECONDARY	240	1

EFFECTIVITY CODE

1. CJ-180 AND AFTER

Beechcraft
BONANZA
WIRING DIAGRAM MANUAL

32-30-02

Configuration 1

**E-1911 THRU E-1945, E-1947 THRU E-2103, E-2105 THRU E-2110;
CE-969 THRU CE-1300, CE-1302 THRU CE-1306; D-10380 AND AFTER;
EA-256 THRU EA-319, EA-321 THRU EA-388**

Beechcraft
BONANZA
WIRING DIAGRAM MANUAL

REFERENCE DESIGNATOR	PART NUMBER	DESCRIPTION	USABLE	
			INSTL ZONE	ON CODE
32-30-02 (Configuration 1)				
B21	58-380090-5	MOTOR-LANDING GEAR	150	1
CB18	7277-2-5	CIRCUIT BREAKER-LANDING GEAR POSITION	240	1
CB19	MS24510-30	CIRCUIT BREAKER-LANDING GEAR	240	1
CR22	1.5KE51CA	TRANSZORB-DYNAMIC BRAKE RELAY	270	1
CR23	1.5KE51CA	TRANSZORB-DYNAMIC BRAKE RELAY	270	1
GS1	131270-3	GROUND STUD-MAIN SPAR	270	1
J115A	206705-2	RECEPTACLE-LANDING GEAR SAFETY SWITCH, LEFT (OPTL)	532	1
J115B	206966-1	CABLE CLAMP	532	1
J115C	66103-2	PIN CONTACT	532	1
J116	207443-1	RECEPTACLE-LANDING GEAR SAFETY SWITCH RELAY ASSEMBLY	251	1
J54A	206151-2	RECEPTACLE-JUNCTION BOX ASSEMBLY	231	1
J54B	206138-1	STRAIN CLAMP RELIEF	231	1
J54C	66103-2	PIN CONTACT	231	1
J56	206036-3	RECEPTACLE-LANDING GEAR LIMIT SWITCH	150	1
J82A	206153-1	RECEPTACLE-RIGHT LANDING GEAR SAFETY SWITCH	632	1
J82B	206062-1	STRAIN RELIEF	632	1
J82C	66103-2	PIN CONTACT	632	1
J85A	1-480288-0	RECEPTACLE-CROSSOVER DISCONNECT	251	1
J85B	60618-1	PIN CONTACT	251	1
K17	6046H39B	RELAY-LANDING GEAR DYNAMIC BRAKE	150	1
P115A	206708-1	PLUG-LANDING GEAR SAFETY SWITCH, LEFT (OPTL)	550	1
P115B	206966-1	CABLE CLAMP (OPTL)	550	1
P115C	66105-2	SOCKET (OPTL)	550	1
P116	207442-1	PLUG-LANDING GEAR SAFETY SWITCH RELAY ASSEMBLY	251	1
P54A	206150-1	PLUG-JUNCTION BOX ASSEMBLY	231	1
P54B	206138-1	STRAIN RELIEF	231	1
P54C	66105-2	SOCKET CONTACT	231	1
P56	1-480283-0	PLUG-LANDING GEAR LIMIT SWITCH	150	1
P82A	206060-1	PLUG-LANDING GEAR SAFETY SWITCH, RIGHT	632	1
P82B	206062-1	STRAIN RELIEF	632	1
P82C	66105-2	SOCKET CONTACT	632	1
P85A	1-480287-0	PLUG-CROSSOVER DISCONNECT	251	1
P85B	66017-1	SOCKET CONTACT	251	1
S36	BZ-3AT	SWITCH-LANDING GEAR SAFETY, RIGHT	740	1
S38	8857K44	SWITCH-LANDING GEAR (ALTN FOR MS25125-E3)	240	1
S38	MS25125-E3	SWITCH-LANDING GEAR (ALTN FOR 8857K44)	240	1
S39	MS25008-1	SWITCH-LANDING GEAR UPLIMIT	251	1
S40	MS25026-1	SWITCH-LANDING GEAR DOWNLIMIT	251	1
S45	MS25026-1	SWITCH-LANDING GEAR DOWNLIMIT	251	1
S73A	002-361013-55	SWITCH ASSEMBLY-LANDING GEAR SAFETY, LEFT	730	1
S73B	MS25008-1	SWITCH-LANDING GEAR SAFETY, LEFT	730	1
S73C	MCD2711	ACTUATOR-LANDING GEAR SAFETY, LEFT	730	1
W13	114931-12	BUS-MAIN	240	1

Beechcraft
BONANZA
WIRING DIAGRAM MANUAL

REFERENCE DESIGNATOR	PART NUMBER	DESCRIPTION	USABLE INSTL ON ZONE CODE
		32-30-02 (Configuration 1)	
W19	114931-10	BUS-SECONDARY	240 1

EFFECTIVITY CODE

1. E-1911 THRU E-1945, E-1947 THRU E-2103, E-2105 THRU E-2110; CE-969 THRU CE-1300,
 CE-1302 THRU CE-1306; D-10380 AND AFTER; EA-256 THRU EA-319, EA-321 THRU EA-388

Beechcraft
BONANZA
WIRING DIAGRAM MANUAL

32-30-02

Configuration 2

CE-1301, CE-1307 AND AFTER

Beechcraft BONANZA WIRING DIAGRAM MANUAL

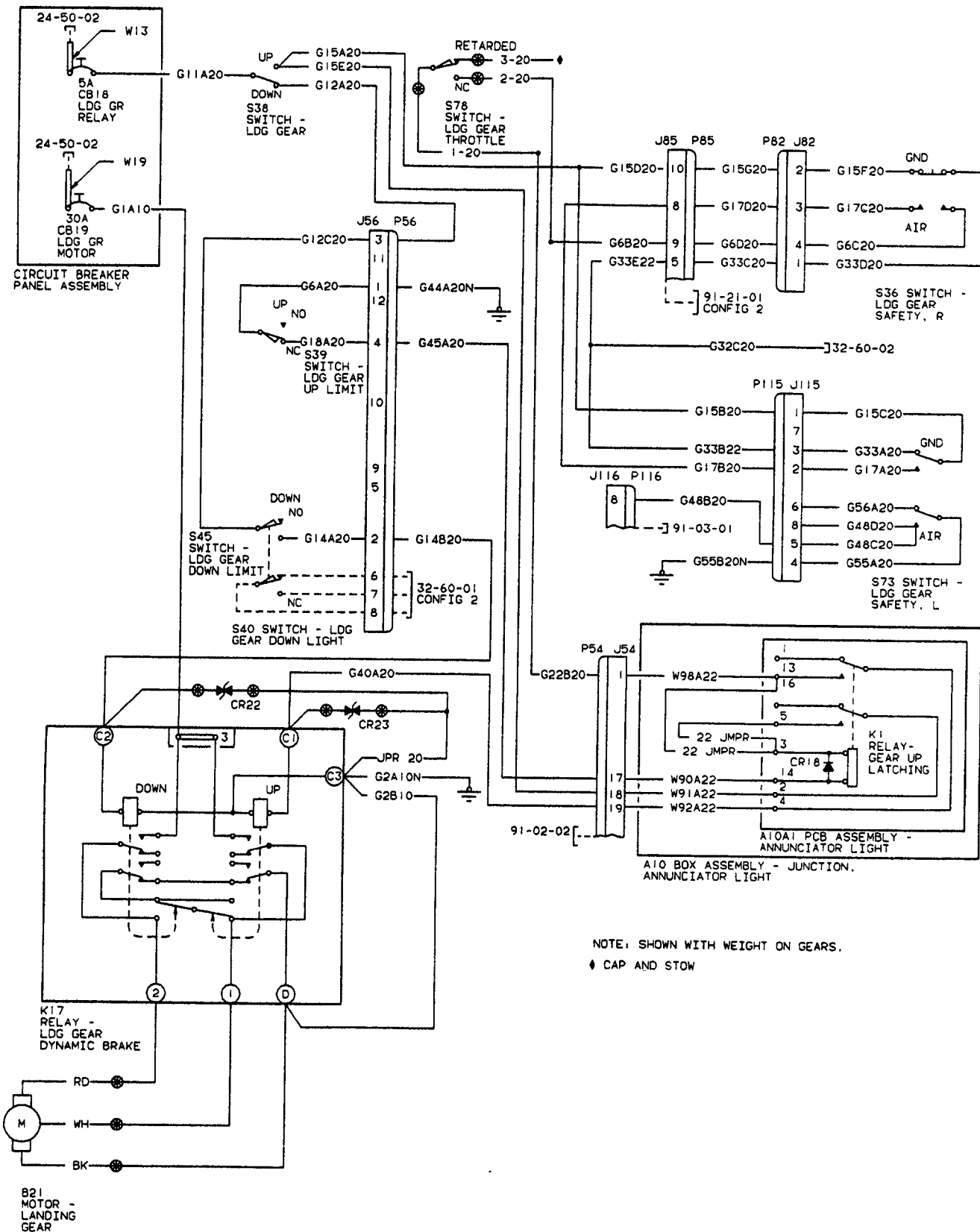

NOTE: SHOWN WITH WEIGHT ON GEARS.
♦ CAP AND STOW

**LANDING GEAR-MOTOR AND RELAY
(Configuration 2)**

Raytheon Aircraft

BEECH BONANZA WIRING DIAGRAM MANUAL

REFERENCE DESIGNATOR	PART NUMBER	DESCRIPTION	INSTL ZONE	USABLE ON CODE
32-30-02				
(Configuration 2)				
A10	58-364056-15	BOX ASSEMBLY-JUNCTION ANNUNCIATOR LIGHT	231	1
A10A1	58-364056-9	PRINTED CIRCUIT BOARD ASSY-ANNUNCIATOR LIGHT	231	1
A10A1CR18	1N4007	DIODE (SUPERSEDED BY 132408-22)	231	1
A10A1CR18	132408-22	DIODE (SUPERSEDES 1N4007)	231	1
A10A1K1	50-384112-1	RELAY-GEAR UP LATCHING	231	1
B21	58-380090-5	MOTOR-LANDING GEAR	150	1
CB18	7277-2-5	CIRCUIT BREAKER-LANDING GEAR POSITION	240	1
CB19	MS24510-30	CIRCUIT BREAKER-LANDING GEAR	240	1
CR22	1.5KE51CA	TRANSZORB-DYNAMIC BRAKE RELAY	270	1
CR23	1.5KE51CA	TRANSZORB-DYNAMIC BRAKE RELAY	270	1
J115A	206705-2	RECEPTACLE-LDG GEAR SAFETY SW, LEFT (OPTL)	532	1
J115B	206966-1	CABLE CLAMP	532	1
J115C	66103-2	PIN CONTACT	532	1
J116	207443-1	RECEPTACLE-LDG GEAR SAFETY SW RELAY ASSY	251	1
J54A	206151-2	RECEPTACLE-JUNCTION BOX ASSEMBLY	231	1
J54B	206138-1	STRAIN CLAMP RELIEF	231	1
J54C	66103-2	PIN CONTACT	231	1
J82A	206153-1	RECEPTACLE-RIGHT LANDING GEAR SAFETY SWITCH	632	1
J82B	206062-1	STRAIN RELIEF	632	1
J82C	66103-2	PIN CONTACT	632	1
J85A	1-480288-0	RECEPTACLE-CROSSOVER DISCONNECT	251	1
J85B	60618-1	PIN CONTACT	251	1
K17	6046H39B	RELAY-LANDING GEAR DYNAMIC BRAKE	150	1
P115A	206708-1	PLUG-LANDING GEAR SAFETY SWITCH, LEFT (OPTL)	550	1
P115B	206966-1	CABLE CLAMP (OPTL)	550	1
P115C	66105-2	SOCKET (OPTL)	550	1
P116	207442-1	PLUG-LDG GEAR SAFETY SWITCH RELAY ASSY	251	1
P54A	206150-1	PLUG-JUNCTION BOX ASSEMBLY	231	1
P54B	206138-1	STRAIN RELIEF	231	1
P54C	66105-2	SOCKET CONTACT	231	1
P56A	207017-1	PLUG-LANDING GEAR LIMIT SWITCH	150	1
P56B	66105-2	SOCKET CONTACT	150	1
P82A	206060-1	PLUG-LANDING GEAR SAFETY SWITCH, RIGHT	632	1
P82B	206062-1	STRAIN RELIEF	632	1
P82C	66105-2	SOCKET CONTACT	632	1
P85A	1-480287-0	PLUG-CROSSOVER DISCONNECT	251	1
P85B	66017-1	SOCKET CONTACT	251	1
S36	BZ-3AT	SWITCH-LANDING GEAR SAFETY, RIGHT	740	1
S38	8857K44	SWITCH-LANDING GEAR (ALTN FOR MS25125-E3)	240	1
S38	MS25125-E3	SWITCH-LANDING GEAR (ALTN FOR 8857K44)	240	1
S39	MS25008-1	SWITCH-LANDING GEAR UPLIMIT	251	1
S40	MS25026-1	SWITCH-LANDING GEAR DOWNLIMIT	251	1
S45	MS25026-1	SWITCH-LANDING GEAR DOWNLIMIT	251	1
S73A	002-361013-55	SWITCH ASSEMBLY-LANDING GEAR SAFETY, LEFT	730	1
S73B	MS25008-1	SWITCH-LANDING GEAR SAFETY, LEFT	730	1
S73C	MCD2711	ACTUATOR-LANDING GEAR SAFETY, LEFT	730	1
S78	A5-103-1031	THROTTLE, LANDING GEAR	410	1
W13	114931-12	BUS-MAIN	240	1
W19	114931-10	BUS-SECONDARY	240	1

CODES OF EFFECTIVITY

1. CE-1301, CE-1307 AND AFTER

Beechcraft BONANZA WIRING DIAGRAM MANUAL

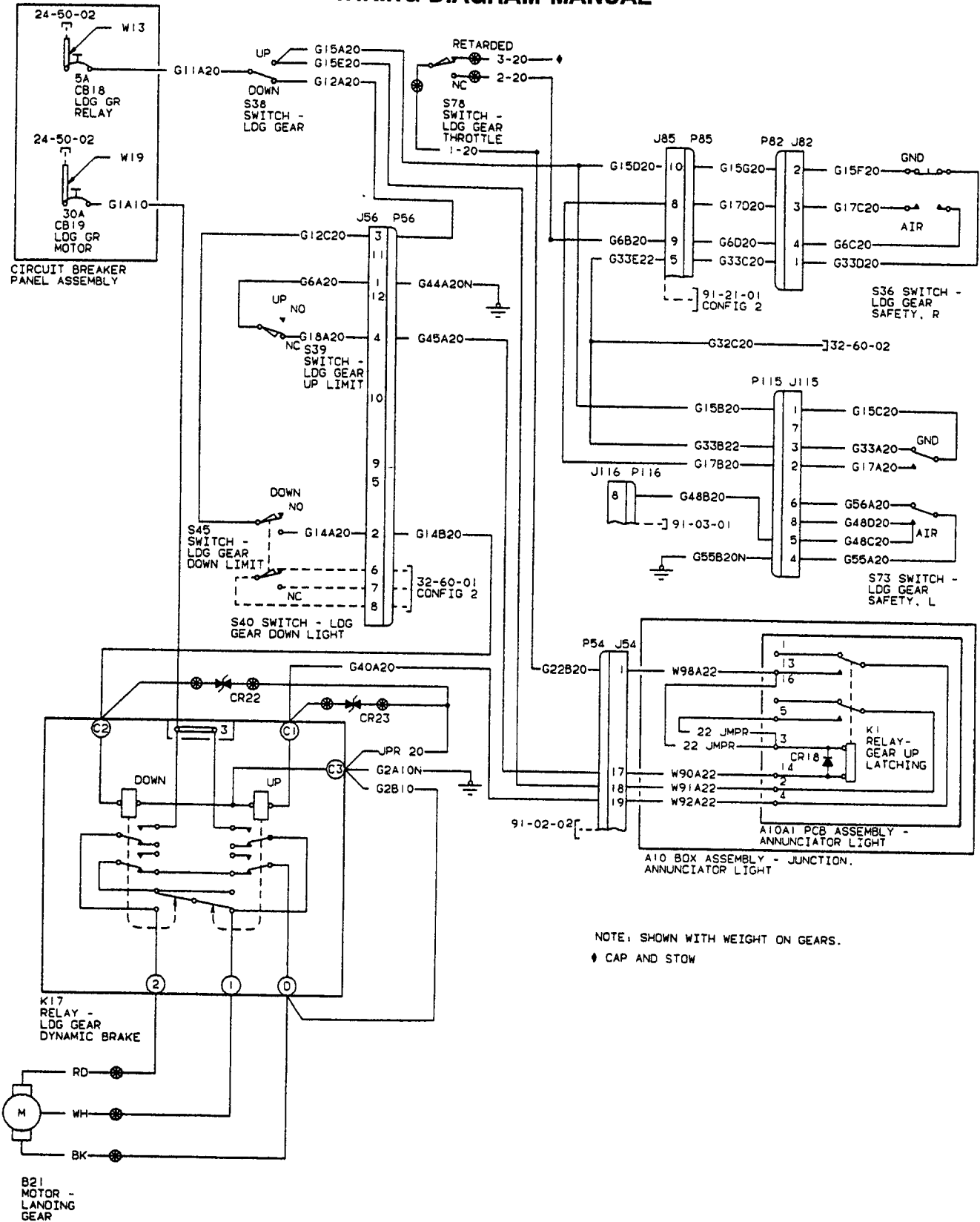

**LANDING GEAR-MOTOR AND RELAY
(Configuration 2)**

Beechcraft
BONANZA
WIRING DIAGRAM MANUAL

REFERENCE DESIGNATOR	PART NUMBER	DESCRIPTION	USABLE	
			INSTL	ON ZONE CODE
32-30-02 (Configuration 2)				
W13	114931-12	BUS-MAIN	240	1
W19	114931-10	BUS-SECONDARY	240	1

EFFECTIVITY CODE

1. CE-1301, CE-1307 AND AFTER

Raytheon Aircraft

BEECH BONANZA WIRING DIAGRAM MANUAL

32-31-01

LANDING GEAR-SAFETY SYSTEM (OPTIONAL)

E-1111, E-1241 THRU E-1910; CE-748, CE-772 THRU CE-968; CJ-149 AND AFTER; D-10097, D-10120 THRU D-10379; EA-1 THRU EA-255

Raytheon Aircraft

BEECH BONANZA WIRING DIAGRAM MANUAL

REFERENCE DESIGNATOR	PART NUMBER	DESCRIPTION	INSTL ZONE	USABLE ON CODE
32-31-01				
B21	58-380090-5	MOTOR-LANDING GEAR	150	3
B21	96-380022-5	MOTOR-LANDING GEAR	150	2
CB13	7277-2-5	CIRCUIT BREAKER-LANDING GEAR SAFETY SWITCH	240	5
CB13	435-205-104	CIRCUIT BREAKER-LANDING GEAR SAFETY SWITCH	240	4
CB18	7277-2-5	CIRCUIT BREAKER-LANDING GEAR POSITION	240	5
CB18	435-205-104	CIRCUIT BREAKER-LANDING GEAR POSITION	240	4
CB19	MS24510-30	CIRCUIT BREAKER-LANDING GEAR	240	5
CB19	CB2330	CIRCUIT BREAKER-LANDING GEAR	240	4
CR22	1.5KE51CA	TRANSZORB-DYNAMIC BRAKE	270	1
CR23	1.5KE51CA	TRANSZORB-DYNAMIC BRAKE	270	1
CR35	1N4007	DIODE-LANDING GEAR LATCH-IN RELAY (SUPER- SEDED BY 132408-22)	240	1
CR35	132408-22	DIODE-LANDING GEAR LATCH-IN RELAY (SUPER- SEDES 1N4007)	240	1
CR36	1N5400	DIODE-LANDING GEAR SAFETY SWITCH	240	1
GS1	131270-3	GROUND STUD-MAIN SPAR	270	1
J54A	206152-1	RECEPTACLE-JUNCTION BOX ASSEMBLY	231	9
J54A	206151-2	RECEPTACLE-JUNCTION BOX ASSEMBLY	231	10
J54B	206070-1	STRAIN RELIEF CLAMP	231	9
J54B	206138-1	STRAIN RELIEF CLAMP	231	10
J54C	1-205202-6	PIN CONTACT	231	9
J54C	66103-2	PIN CONTACT	231	10
J56	206036-3	RECEPTACLE-LANDING GEAR LIMIT SWITCH	150	6
J80	204814-1	RECEPTACLE-GROUNDING BLOCK	231	1
J81A	206153-1	RECEPTACLE-LANDING GEAR SAFETY SWITCH, LEFT	532	1
J81B	66099-2	PIN CONTACT	532	1
J82A	206153-1	RECEPTACLE-RIGHT LANDING GEAR SAFETY SWITCH	632	1
J82B	206062-1	STRAIN RELIEF	632	1
J82C	66103-2	PIN CONTACT	632	1
J85A	1-480288-0	RECEPTACLE-CROSSOVER DISCONNECT	251	1
J85B	60618-1	PIN CONTACT	251	1
K17	6046H39B	RELAY-LANDING GEAR DYNAMIC BREAK	150	8
K17	6046H39A	RELAY-LANDING GEAR DYNAMIC BREAK	150	7
K19	50-380048-1	RELAY-LANDING GEAR LATCH-IN (OPTL)	240	1
P54A	205839-3	PLUG-JUNCTION BOX ASSEMBLY	231	9
P54A	206150-1	PLUG-JUNCTION BOX ASSEMBLY	231	10
P54B	205089-1	SOCKET CONTACT	231	9
P54B	206138-1	STRAIN RELIEF	231	10
P54C	66105-2	SOCKET CONTACT	231	10
P56	1-480283-0	PLUG-LANDING GEAR LIMIT SWITCH	150	6
P56A	207017-1	PLUG-LANDING GEAR LIMIT SWITCH	150	11
P56B	66105-2	SOCKET CONTACT	150	11
P80A	200838-3	PLUG-GROUNDING BLOCK	231	1
P80B	201224-1	STRAIN RELIEF	231	1
P80C	201328-1	SOCKET CONTACT	231	1
P80D	200333-1	SOCKET CONTACT	231	1
P80E	203618-1	JACKSCREW	231	1
P81A	206060-1	PLUG-LANDING GEAR SAFETY SWITCH, LEFT	532	1
P81B	660101-2	SOCKET CONTACT	532	1
P82A	206060-2	PLUG HOUSING-LANDING GEAR SAFETY SWITCH, RIGHT	632	1
P82B	66101-2	SOCKET CONTACT	632	1

Raytheon Aircraft

BEECH BONANZA WIRING DIAGRAM MANUAL

REFERENCE DESIGNATOR	PART NUMBER	DESCRIPTION	INSTL ZONE	USABLE ON CODE
32-31-01				
P85A	1-480287-0	PLUG-CROSSOVER DISCONNECT	251	1
P85B	66017-1	SOCKET CONTACT	251	1
S30A	35-380053-11	SWITCH-LANDING GEAR SAFETY SYSTEM (OPTL)	240	1
S30B	96-384050-7	KNOB (OPTL)	240	1
S32	35-364171-27	SWITCH-LANDING GEAR (OPTL)	240	1
S33	90-380010-5	SWITCH-120 MPH AIRSPEED (OPTL)	532	1
S34	V3-1	SWITCH-THROTTLE, SAFETY SYSTEM	410	1
S35	90-380010-3	SWITCH-90 MPH AIRSPEED (OPTL)	532	1
S36	MS25026-1	SWITCH-LANDING GEAR SAFETY SWITCH, RIGHT	740	1
S37	MS25026-1	SWITCH-LANDING GEAR SAFETY SWITCH, LEFT	730	1
S39	MS25026-1	SWITCH-LANDING GEAR UPLIMIT	150	1
S40	MS25026-1	SWITCH-LANDING GEAR DOWNLIMIT	150	1

CODES OF EFFECTIVITY

1. E-1111, E-1241 THRU E-1910; CE-748, CE-772 THRU CE-968; CJ-149 AND AFTER; D-10097, D-10120 THRU D-10379; EA-1 THRU EA-255
2. E-1111, E-1241 THRU E-1625; CE-748, CE-772 THRU CE-895; CJ-149 THRU CJ-159; D-10097, D-10120 THRU D-10324; EA-1 THRU EA-48
3. E-1626 THRU E-1910; CE-896 THRU CE-968; CJ-160 AND AFTER; D-10325 THRU D-10379; EA-49 THRU EA-255
4. E-1111, E-1241 THRU E-1765; CE-748, CE-772 THRU CE-918, CE-920 THRU CE-928; CJ-149 THRU CJ-155; D-10097, D-10120 THRU D-10347, D-10349 THRU D-10353; EA-1 THRU EA-158
5. E-1766 THRU E-1910; CE-919, CE-929 THRU CE-968; CJ-156 AND AFTER; D-10348, D-10354 THRU D-10379; EA-159 THRU EA-255
6. E-1111, E-1241 THRU E-1910; CE-748, CE-772 THRU CE-968; CJ-149 THRU CJ-179; D-10097, D-10120 THRU D-10379; EA-1 THRU EA-255
7. E-1111, E-1241 THRU E-1905; CE-748, CE-772 THRU CE-967; CJ-149 THRU CJ-155; D-10097, D-10120 THRU D-10378; EA-1 THRU EA-253
8. E-1906 THRU E-1910; CE-968 ONLY; CJ-156 AND AFTER; D-10379 ONLY; EA-254 AND EA-255
9. E-1111, E-1241 THRU E-1370; CE-748, CE-772 THRU CE-815; D-10097, D-10120 THRU D-10178; EA-1 ONLY
10. E-1371 THRU E-1910; CE-816 THRU CE-968; CJ-149 AND AFTER; D-10179 THRU D-10379; EA-2 THRU EA-255
11. CJ-180 AND AFTER

Raytheon Aircraft

BEECH BONANZA WIRING DIAGRAM MANUAL

32-31-02

LANDING GEAR-SAFETY SYSTEM (OPTIONAL)

E-1911 THRU E-1945, E-1947 THRU E-2103, E-2105 THRU E-2110; CE-969 AND AFTER; D-10380 AND AFTER; EA-256 THRU EA-319, EA-321 THRU EA-388

Raytheon Aircraft

BEECH BONANZA WIRING DIAGRAM MANUAL

REFERENCE DESIGNATOR	PART NUMBER	DESCRIPTION	INSTL ZONE	USABLE ON CODE
32-31-02				
B21	58-380090-5	MOTOR-LANDING GEAR	150	1
CB18	7277-2-5	CIRCUIT BREAKER-LANDING GEAR POSITION	240	1
CB19	MS24510-30	CIRCUIT BREAKER-LANDING GEAR	240	1
CR22	1.5KE51CA	TRANSZORB-DYNAMIC BRAKE	270	1
CR23	1.5KE51CA	TRANSZORB-DYNAMIC BRAKE	270	1
CR35	1N4007	DIODE-LANDING GEAR LATCH-IN RELAY (SUPER- SEDED BY 132408-22)	240	1
CR35	132408-22	DIODE-LANDING GEAR LATCH-IN RELAY (SUPER- SEDES 1N4007)	240	1
CR36	1N5400	DIODE-LANDING GEAR SAFETY SWITCH	240	1
GS1	131270-3	GROUND STUD-MAIN SPAR	270	1
GS3	131270-3	GROUND STUD-FIREWALL	221	1
J115A	206705-2	RECEPTACLE-LANDING GEAR SAFETY SW, LEFT (OPTL)	532	1
J115B	206966-1	CABLE CLAMP (OPTL)	532	1
J115C	66103-2	PIN CONTACT (OPTL)	532	1
J54A	206151-2	RECEPTACLE-JUNCTION BOX ASSEMBLY	231	1
J54B	206138-1	STRAIN RELIEF CLAMP	231	1
J54C	66103-2	PIN CONTACT	231	1
J56	206036-3	RECEPTACLE-LANDING GEAR LIMIT SWITCH	150	2
J56A	207018-1	RECEPTACLE-LANDING GEAR LIMIT SWITCH	150	3
J56B	66103-2	PIN CONTACT	150	3
J56C	66602-1	PIN CONTACT	150	3
J80	204814-1	RECEPTACLE-GROUNDING BLOCK	231	1
J82A	206153-1	RECEPTACLE-RIGHT LANDING GEAR SAFETY SWITCH	632	1
J82B	206062-1	STRAIN RELIEF	632	1
J82C	66103-2	PIN CONTACT	632	1
J85A	1-480288-0	RECEPTACLE-CROSSOVER DISCONNECT	251	1
J85B	60618-1	PIN CONTACT	251	1
K17	6046H39B	RELAY-LANDING GEAR DYNAMIC BREAK	150	1
K19	50-380048-1	RELAY-LANDING GEAR LATCH-IN (OPTL)	240	1
P54A	206150-1	PLUG-JUNCTION BOX ASSEMBLY	231	1
P54B	206138-1	STRAIN RELIEF	231	1
P54C	66105-2	SOCKET CONTACT	231	1
P56	1-480283-0	PLUG-LANDING GEAR LIMIT SWITCH	150	2
P56A	207017-1	PLUG-LANDING GEAR LIMIT SWITCH	150	3
P56B	66105-2	SOCKET CONTACT	150	3
P80A	200838-3	PLUG-GROUNDING BLOCK	231	1
P80B	201224-1	STRAIN RELIEF	231	1
P80C	201328-1	SOCKET CONTACT	231	1
P80D	200333-1	SOCKET CONTACT	231	1
P80E	203618-1	JACKSCREW	231	1
P82A	206060-2	PLUG HOUSING-LANDING GEAR SAFETY SWITCH, RIGHT	632	1
P82B	66101-2	SOCKET CONTACT	632	1
P85A	1-480287-0	PLUG-CROSSOVER DISCONNECT	251	1
P85B	66017-1	SOCKET CONTACT	251	1
S30A	35-380053-11	SWITCH-LANDING GEAR SAFETY SYSTEM (OPTL)	240	1
S30B	96-384050-7	KNOB (OPTL)	240	1
S32	35-364171-27	SWITCH-LANDING GEAR (OPTL)	240	1
S33	90-380010-5	SWITCH-120 MPH AIRSPEED (OPTL)	532	1
S34	V3-1	SWITCH-THROTTLE, SAFETY SYSTEM	410	1

Raytheon Aircraft

BEECH BONANZA WIRING DIAGRAM MANUAL

REFERENCE		DESCRIPTION	USABLE	
DESIGNATOR	PART NUMBER		INSTL ZONE	ON CODE
32-31-02				
S35	90-380010-3	SWITCH-90 MPH AIRSPEED (OPTL)	532	1
S36	MS25026-1	SWITCH-LANDING GEAR SAFETY SWITCH, RIGHT	740	1
S39	MS25026-1	SWITCH-LANDING GEAR UPLIMIT	150	2
S39	MS25008-1	SWITCH-LANDING GEAR UPLIMIT	150	3
S40	MS25026-1	SWITCH-LANDING GEAR DOWNLIMIT	150	1
S45	MS25026-1	SWITCH-LANDING GEAR DOWNLIMIT	251	1
S73A	002-361013-47	SWITCH ASSEMBLY-LANDING GEAR SAFETY, LEFT	730	1
S73B	MS25008-1	SWITCH-LANDING GEAR SAFETY, LEFT	730	1
S73C	MCD2711	ACTUATOR-LANDING GEAR SAFETY SWITCH	730	1
W13	114931-1-12	BUS-MAIN	240	1
W19	114931-1-10	BUS-SECONDARY	240	1

CODES OF EFFECTIVITY

1. E-1911 THRU E-1945, E-1947 THRU E-2103, E-2105 THRU E-2110; CE-969 AND AFTER; D-10380 AND AFTER; EA-256 THRU EA-319, EA-321 THRU EA-388
2. E-1911 THRU E-1945, E-1947 THRU E-2103, E-2105 THRU E-2110; CE-969 THRU CE-1300, CE-1302 THRU CE-1306; D-10380 AND AFTER; EA-256 THRU EA-319, EA-321 THRU EA-388
3. CE-1301, CE-1307 AND AFTER

Beechcraft
BONANZA
WIRING DIAGRAM MANUAL

32-60-01

Configuration 1

**E-1111, E-1241 THRU E-1945, E-1947 THRU E-2103, E-2105 THRU
E-2110; CE-748, CE-772 THRU CE-1300, CE-1302 THRU CE-1306;
CJ-149 THRU CJ-179; D-10097, D-10120 AND AFTER; EA-1 THRU
EA-319, EA-321 THRU EA- 388**

Beechcraft
BONANZA
WIRING DIAGRAM MANUAL

REFERENCE DESIGNATOR	PART NUMBER	DESCRIPTION	USABLE	
			INSTL ZONE	ON CODE
32-60-01 (Configuration 1)				
CB29	435-205-104	CIRCUIT BREAKER-LANDING GEAR THROTTLE	240	2
CB29	7277-2-5	CIRCUIT BREAKER-LANDING GEAR THROTTLE	240	3
DS144	327	WARNING LIGHT-GEAR IN-TRANSIT	240	1
DS145	327	INDICATOR LIGHT-NOSE GEAR DOWN	240	1
DS146	327	INDICATOR LIGHT-LANDING GEAR DOWN, LEFT	240	1
DS147	327	INDICATOR LIGHT-LANDING GEAR DOWN, RIGHT	240	1
GS1	131270-3	GROUND STUD-MAIN SPAR	270	1
GS3	131270-3	GROUND STUD-FIREWALL	221	1
GS5	131270-3	GROUND STUD-FWD WEB MAIN SPAR	231	4
J10A	206036-3	RECEPTACLE-LEFT WHEEL WELL ACCESS	532	1
J10B	206070-1	STRAIN RELIEF	532	1
J10C	66103-2	PIN CONTACT	532	1
J10D	66099-2	PIN CONTACT	532	1
J11A	206036-3	RECEPTACLE-WHEEL WELL ACCESS, RIGHT	632	1
J11B	206070-1	STRAIN RELIEF	632	1
J11C	66099-2	PIN CONTACT	632	1
J11D	66103-2	PIN CONTACT	632	1
J54A	206151-2	RECEPTACLE-JUNCTION BOX ASSEMBLY	231	6
J54A	206152-1	RECEPTACLE-JUNCTION BOX ASSEMBLY	231	5
J54B	206138-1	STRAIN RELIEF	231	6
J54B	206070-1	STRAIN RELIEF CLAMP	231	5
J54C	66103-2	PIN CONTACT	231	6
J54C	1-205202-6	PIN CONTACT	231	5
J56	206036-3	RECEPTACLE-LANDING GEAR LIMIT SWITCH	150	1
J59A	1-480340-0	RECEPTACLE-LANDING GEAR POSITION LIGHT	240	7
J59B	60618-1	PIN CONTACT	240	7
J85A	1-480288-0	RECEPTACLE-CROSSOVER DISCONNECT	251	1
J85B	60618-1	PIN CONTACT	251	1
P10A	206037-1	PLUG-LEFT WHEEL WELL ACCESS	532	1
P10B	66101-2	SOCKET CONTACT	532	1
P10C	66105-2	SOCKET CONTACT	532	1
P10D	206070-1	STRAIN RELIEF CLAMP	532	1
P11A	206037-1	PLUG-WHEEL WELL ACCESS, RIGHT	632	1
P11B	206070-1	STRAIN RELIEF	632	1
P11C	66101-2	SOCKET CONTACT	632	1
P11D	66105-2	SOCKET CONTACT	632	1
P54A	206150-1	PLUG-JUNCTION BOX ASSEMBLY	231	6
P54A	205839-3	PLUG-JUNCTION BOX ASSEMBLY	231	5
P54B	206138-1	STRAIN RELIEF	231	6
P54B	205089-1	SOCKET CONTACT	231	5
P54C	66105-2	SOCKET CONTACT	231	6
P56	1-480283-0	PLUG-LANDING GEAR LIMIT SWITCH	150	1
P59A	1-480270-0	PLUG-LANDING GEAR POSITION LIGHT	240	1
P59B	60617-1	SOCKET CONTACT	240	1
P85A	1-480287-0	PLUG-CROSSOVER DISCONNECT	251	1
P85B	66017-1	SOCKET CONTACT	251	1
S40	MS25026-1	SWITCH-LANDING GEAR DOWNLIMIT	251	1
S41	V3-1	SWITCH-THROTTLE, LANDING GEAR	410	1

Beechcraft BONANZA WIRING DIAGRAM MANUAL

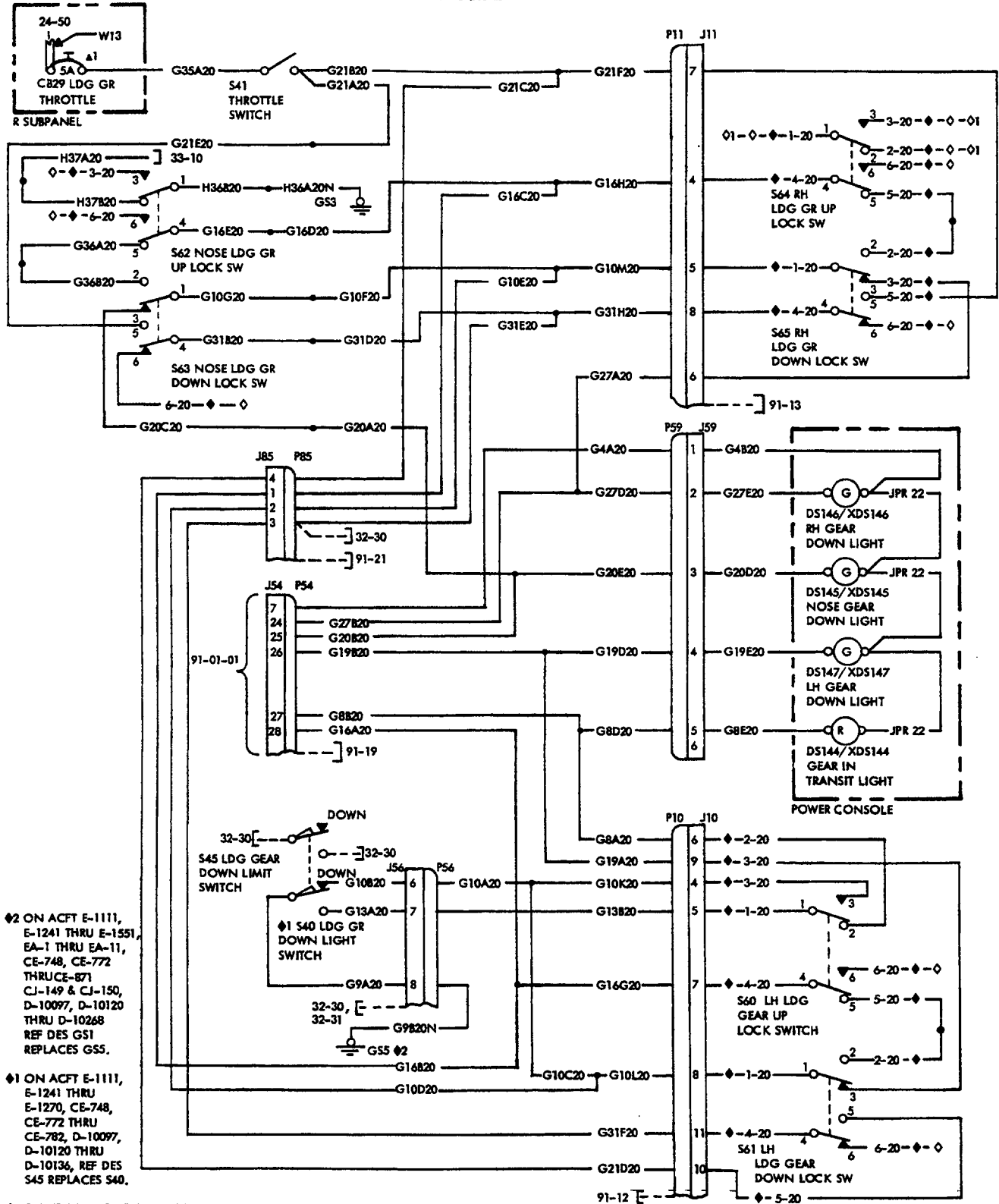

◆2 ON ACFT E-1111, E-1241 THRU E-1551, EA-1 THRU EA-11, CE-748, CE-772 THRU CE-871 CJ-149 & CJ-150, D-10097, D-10120 THRU D-10268 REF DES GS1 REPLACES GS5.

◆1 ON ACFT E-1111, E-1241 THRU E-1270, CE-748, CE-772 THRU CE-782, D-10097, D-10120 THRU D-10136, REF DES S45 REPLACES S40.

◆ STAMP REF DES OF APPLICABLE SWITCH ON HEAT SHRINKABLE TUBING & INSTALL ON WIRE FURNISHED WITH THE EQUIPMENT.

NOTE: GEAR SHOWN IN DOWN POSITION ON GROUND.

LANDING GEAR-POSITION INDICATOR (Configuration 1)

◆1 ON AIRCRAFT HAVING OPTIONAL AIR CONDITIONER INSTALLED, REF DIAG 21-50 FOR WIRING.

◆ TIE UNUSED WIRES INTO HARNESS. CUT OFF AT SPLICE LOCATION.

Beechcraft
BONANZA
WIRING DIAGRAM MANUAL

REFERENCE DESIGNATOR	PART NUMBER	DESCRIPTION	USABLE INSTL ON ZONE CODE	
32-60-01				
(Configuration 1)				
S45	MS25026-1	SWITCH-LANDING GEAR LIGHT DOWN	251	1
S60	100-381006-1	SWITCH-LANDING GEAR UP LOCK, LEFT	730	1
S61	100-381006-1	SWITCH-LANDING GEAR DOWN LOCK, LEFT	730	1
S62	100-381006-1	SWITCH-NOSE LANDING GEAR UP LIMIT	710	1
S63	100-381006-1	SWITCH-NOSE LANDING GEAR DOWN LIMIT	710	1
S64	100-381006-1	SWITCH-LANDING GEAR UP LIMIT, RIGHT	740	1
S65	100-381006-1	SWITCH-LANDING GEAR DOWN LIMIT, RIGHT	740	1
W13	114931-12	BUS-MAIN	240	1
XDS144	855291SI-R2DS-P6	LAMPHOLDER-GEAR IN-TRANSIT	240	1
XDS145	855291SI-G5STD	LAMPHOLDER-NOSE GEAR DOWN	240	1
XDS146	855291SI-G5STD	LAMPHOLDER-LANDING GEAR DOWN, LEFT	240	1
XDS147	855291SI-G5STD	LAMPHOLDER-LANDING GEAR DOWN, RIGHT	240	1

EFFECTIVITY CODE

1. E-1111, E-1241 THRU E-1945, E-1947 THRU E-2103, E-2105 THRU E-2110; CE-748, CE-772 THRU CE-1300, CE-1302 THRU CE-1306; CJ-149 THRU CJ-179; D-10097, D-10120 AND AFTER; EA-1 THRU EA-319, EA-321 THRU EA-388
2. E-1111, E-1241 THRU E-1765; CE-748, CE-772 THRU CE-918, CE-920 THRU CE-928; CJ-149 THRU CJ-155; D-10120 THRU D-10347, D-10349 THRU D-10353; EA-1 THRU EA-158
3. E-1766 THRU E-1945, E-1947 THRU E-2103, E-2105 THRU E-2110; CE-919, CE-929 THRU CE-1300, CE-1302 THRU CE-1306; CJ-156 THRU CJ-179; D-10348, D-10354 AND AFTER; EA-159 THRU EA-319, EA-321 THRU EA-388
4. E-1552 THRU E-1945, E-1947 THRU E-2103, E-2105 THRU E-2110; CE-872 THRU CE-1300, CE-1302 THRU CE-1306; CJ-151 THRU CJ-179; D-10269 AND AFTER; EA-1 THRU EA-319, EA-321 THRU EA-388
5. E-1111, E-1241 THRU E-1370; CE-748, CE-772 THRU CE-815; D-10120 THRU D-10178; EA-1 ONLY
6. E-1371 THRU E-1945, E-1947 THRU E-2103, E-2105 THRU E-2110; CE-816 THRU CE-1300, CE-1302 THRU CE-1306; CJ-149 THRU CJ-179; D-10179 AND AFTER; EA-2 THRU EA-319, EA-321 THRU EA-388
7. CE-748, CE-772 THRU CE-1300, CE-1302 THRU CE-1306; CJ-149 THRU CJ-179; D-10097, D-10120 THRU D-10379

Beechcraft
BONANZA
WIRING DIAGRAM MANUAL

32-60-01

Configuration 2

CE-1301, CE-1307 AND AFTER; CJ-180 AND AFTER

Beechcraft
BONANZA
WIRING DIAGRAM MANUAL

REFERENCE DESIGNATOR	PART NUMBER	DESCRIPTION	USABLE INSTL ON ZONE CODE
32-60-01 (Configuration 2)			
CB29	7277-2-5	CIRCUIT BREAKER-LANDING GEAR THROTTLE	240 1
DS144	327	WARNING LIGHT-GEAR IN-TRANSIT	240 1
DS145	327	INDICATOR LIGHT-NOSE GEAR DOWN	240 1
DS146	327	INDICATOR LIGHT-LANDING GEAR DOWN, LEFT	240 1
DS147	327	INDICATOR LIGHT-LANDING GEAR DOWN, RIGHT	240 1
GS3	131270-3	GROUND STUD-FIREWALL	221 1
GS5	131270-3	GROUND STUD-FWD WEB MAIN SPAR	231 1
J10A	206036-3	RECEPTACLE-LEFT WHEEL WELL ACCESS	532 1
J10B	206070-1	STRAIN RELIEF	532 1
J10C	66103-2	PIN CONTACT	532 1
J10D	66099-2	PIN CONTACT	532 1
J11A	206036-3	RECEPTACLE-WHEEL WELL ACCESS, RIGHT	632 1
J11B	206070-1	STRAIN RELIEF	632 1
J11C	66099-2	PIN CONTACT	632 1
J11D	66103-2	PIN CONTACT	632 1
J54A	206151-2	RECEPTACLE-JUNCTION BOX ASSEMBLY	231 1
J54B	206138-1	STRAIN RELIEF	231 1
J54C	66103-2	PIN CONTACT	231 1
J56A	207018-1	RECEPTACLE-LANDING GEAR LIMIT SWITCH	150 1
J56B	66103-2	PIN CONTACT	150 1
J56C	66602-1	PIN CONTACT	150 1
J59A	1-480340-0	RECEPTACLE-LANDING GEAR POSITION LIGHT	240 1
J59B	60618-1	PIN CONTACT	240 1
J85A	1-480288-0	RECEPTACLE-CROSSOVER DISCONNECT	251 1
J85B	60618-1	PIN CONTACT	251 1
P10A	206037-1	PLUG-LEFT WHEEL WELL ACCESS	532 1
P10B	66101-2	SOCKET CONTACT	532 1
P10C	66105-2	SOCKET CONTACT	532 1
P10D	206070-1	STRAIN RELIEF CLAMP	532 1
P11A	206037-1	PLUG-WHEEL WELL ACCESS, RIGHT	632 1
P11B	206070-1	STRAIN RELIEF	632 1
P11C	66101-2	SOCKET CONTACT	632 1
P11D	66105-2	SOCKET CONTACT	632 1
P54A	206150-1	PLUG-JUNCTION BOX ASSEMBLY	231 1
P54B	206138-1	STRAIN RELIEF	231 1
P54C	66105-2	SOCKET CONTACT	231 1
P56A	207017-1	PLUG-LANDING GEAR LIMIT SWITCH	150 1
P56B	66105-2	SOCKET CONTACT	150 1
P59A	1-480270-0	PLUG-LANDING GEAR POSITION LIGHT	240 1
P59B	60617-1	SOCKET CONTACT	240 1
P85A	1-480287-0	PLUG-CROSSOVER DISCONNECT	251 1
P85B	66017-1	SOCKET CONTACT	251 1
S40	MS25026-1	SWITCH-LANDING GEAR DOWNLIMIT	251 1
S45	MS25026-1	SWITCH-LANDING GEAR LIGHT DOWN	251 1
S60	100-381006-1	SWITCH-LANDING GEAR UP LOCK, LEFT	730 1
S61	100-381006-1	SWITCH-LANDING GEAR DOWN LOCK, LEFT	730 1
S62	100-381006-1	SWITCH-NOSE LANDING GEAR UP LIMIT	710 1
S63	100-381006-1	SWITCH-NOSE LANDING GEAR DOWN LIMIT	710 1

Beechcraft
BONANZA
WIRING DIAGRAM MANUAL

REFERENCE DESIGNATOR	PART NUMBER	DESCRIPTION	USABLE INSTL ON ZONE CODE
32-60-01 (Configuration 2)			
S64	100-381006-1	SWITCH-LANDING GEAR UP LIMIT, RIGHT	740 1
S65	100-381006-1	SWITCH-LANDING GEAR DOWN LIMIT, RIGHT	740 1
W13	114931-12	BUS-MAIN	240 1
XDS144	855291SI-R2DS-P6	LAMPHOLDER-GEAR IN-TRANSIT	240 1
XDS145	855291SI-G5STD	LAMPHOLDER-NOSE GEAR DOWN	240 1
XDS146	855291SI-G5STD	LAMPHOLDER-LANDING GEAR DOWN, LEFT	240 1
XDS147	855291SI-G5STD	LAMPHOLDER-LANDING GEAR DOWN, RIGHT	240 1

EFFECTIVITY CODE

1. CE-1301, CE-1307 AND AFTER; CJ-180 AND AFTER

Beechcraft
BONANZA
WIRING DIAGRAM MANUAL

32-60-02

CE-1301, CE-1307 AND AFTER; CJ-180 AND AFTER

Beechcraft BONANZA WIRING DIAGRAM MANUAL

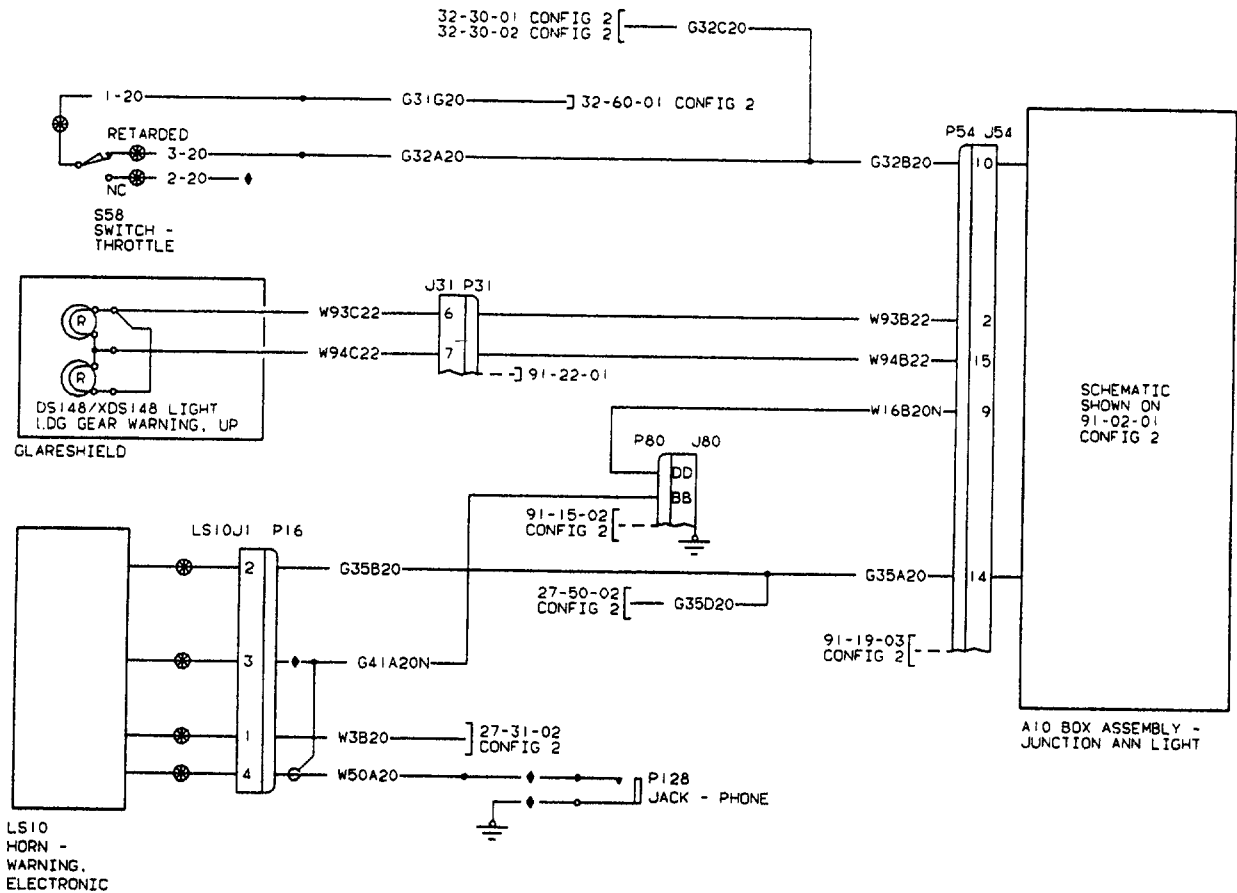

◆ CAP AND STOW

POSITION AND WARNING-THROTTLE AND AIRSPEED

Beechcraft
BONANZA
WIRING DIAGRAM MANUAL

REFERENCE DESIGNATOR	PART NUMBER	DESCRIPTION	USABLE	
			INSTL ZONE	ON CODE
32-60-02				
DS148	327	LAMP-LANDING GEAR UP WARNING LIGHT	240	1
J54A	206151-2	RECEPTACLE-JUNCTION BOX ASSEMBLY	231	1
J54B	206138-1	STRAIN RELIEF	231	1
J54C	66103-2	PIN CONTACT	231	1
J80	204814-1	RECEPTACLE-GROUNDING BLOCK	231	1
LS10	102-384040-1	HORN-ELECTRONIC WARNING	231	1
LS10J1A	207016-1	RECEPTACLE-ELECTRONIC WARNING HORN	231	1
LS10J1B	66103-2	SOCKET CONTACT	231	1
P16A	207015-1	PLUG-ELECTRONIC WARNING HORN	231	1
P16B	66105-2	SOCKET CONTACT	231	1
P16C	206070-1	CABLE CLAMP	231	1
P31A	1-480270-0	PLUG-GLARESHIELD	231	1
P31B	1-480283-0	SOCKET HOUSING	231	1
P31C	60617-1	SOCKET CONTACT	231	1
P54A	206150-1	PLUG-JUNCTION BOX ASSEMBLY	231	1
P54B	206138-1	STRAIN RELIEF	231	1
P54C	66105-2	SOCKET CONTACT	231	1
P80A	200838-3	PLUG-GROUNDING BLOCK	231	1
P80B	201224-1	STRAIN RELIEF	231	1
P80C	201328-1	SOCKET CONTACT	231	1
P80D	200333-1	SOCKET CONTACT	231	1
P80E	203618-1	JACKSCREW	231	1
S58	ISE1-6	SWITCH-THROTTLE	410	1
XDS148	WCD421-ABE02	LAMPHOLDER-LANDING GEAR WARNING LIGHT	240	1

EFFECTIVITY CODE

1. CE-1301, CE-1307 AND AFTER; CJ-180 AND AFTER

CHAPTER

33

LIGHTS

Raytheon Aircraft

BEECH BONANZA WIRING DIAGRAM MAMUAL

LIST OF PAGES & TABLE OF CONTENTS for CHAPTER 33 - LIGHTS

SYS/SUB-SYS/ CHAP SECTION	PAGE NO.	EFFECTIVE DATE	TABLE OF CONTENTS
33-10-01	Page 1 Page 2 Page 3 Page 4 Page 5	Oct/95 Oct/95 Oct/95 Oct/95 Oct/95	LIGHTS - ANNUNCIATOR , FLIGHT COMPARTMENT E-1111, E-1241 THRU E-1765; CE-748, CE-772 THRU CE- 918, CE-920 THRU CE-922, CE-924, CE-926, CE-928; CJ-149 THRU CJ-155; D-10097, D-10120 THRU D-10353; EA-1 THRU EA-158
33-10-02 (Config 1)	Page 1 Page 2 Page 3	Oct/95 Oct/95 Oct/95	LIGHTS - ANNUNCIATOR TEST, FLIGHT COMPARTMENT E-1766 THRU E-1945, E-1947 THRU E-2103, E-2105 THRU E-2110; CE-919, CE-923, CE-925, CE-927, CE-929 THRU CE-1055; D-10354 THRU D-10403; EA-159 THRU EA-319, EA-321 THRU EA-388
33-10-02 (Config 2)	Page 1 Page 2 Page 3	Oct/95 Oct/95 01/29/99	LIGHTS - ANNUNCIATOR TEST, FLIGHT COMPARTMENT CE-1056 THRU CE-1300, CE-1302 THRU CE-1306; CJ-156 THRU CJ-179; D-10404 AND AFTER
33-10-02 (Config 3)	Page 1 Page 2 Page 3	Oct/95 Oct/95 Oct/95	LIGHTS - ANNUNCIATOR TEST, FLIGHT COMPARTMENT CE-1301, CE-1307 AND AFTER; CJ-180 AND AFTER
33-11-01	Page 1 Page 2 Page 3	Oct/95 Oct/95 Oct/95	LIGHTS - MAP, COMPASS, OAT AND FUEL SELECT E-1111, E-1241 THRU E-1517; CE-748, CE-772 THRU CE- 861; CJ-149 ONLY; D-10097, D-10120 THRU D-10247; EA-1 THRU EA-5
33-11-02 (Config 1)	Page 1 Page 2 Page 3	Oct/95 Oct/95 Oct/95	LIGHTS - MAP, COMPASS, OAT AND FUEL SELECT E-1518 THRU E-1945, E-1947 THRU E-2103, E-2105 THRU E-2110; CE-862 THRU CE-1300, CE-1302 THRU CE-1306; CJ-150 THRU CJ-179; D-10248 AND AFTER; EA-6 THRU EA-319, EA-321 THRU EA-388
33-11-02 (Config 2)	Page 1 Page 2 Page 3	Oct/95 Oct/95 Oct/95	LIGHTS - MAP, COMPASS, OAT AND FUEL SELECT CE-1301, CE-1307 AND AFTER; CJ-180 AND AFTER
33-12-01	Page 1 Page 2 Page 3	Oct/95 Oct/95 Oct/95	LIGHTS - ENGINE INSTRUMENT WEDGE (OPTIONAL) E-1111, E-1241 THRU E-1666; CE-748, CE-772 THRU CE-901; CJ-149 THRU CJ-155; D-10097, D-10120 THRU D-10342; EA-1 THRU EA-70
33-12-02	Page 1 Page 2 Page 3	Oct/95 Oct/95 Oct/95	LIGHTS - ENGINE INSTRUMENT WEDGE (OPTIONAL) E-1667 THRU E-1945, E-1947 THRU E-1999; CE-902 THRU CE-993; D-10343 THRU D-10391; EA-71 THRU EA-296
33-12-03	Page 1 Page 2 Page 3	Oct/95 Oct/95 Oct/95	LIGHTS - ENGINE INSTRUMENT WEDGE (OPTIONAL) E-2000 THRU E-2103, E-2105 THRU E-2110; CE-994 AND AFTER; D-10392 AND AFTER; EA-297 THRU EA-319, EA- 321 THRU EA-388

Raytheon Aircraft

BEECH BONANZA WIRING DIAGRAM MANUAL

LIST OF PAGES & TABLE OF CONTENTS (Continued)
for
CHAPTER 33 - LIGHTS

SYS/SUB-SYS/ CHAP SECTION	PAGE NO.	EFFECTIVE DATE	TABLE OF CONTENTS
33-13-01	Page 1 Page 2 Page 3	Oct/95 Oct/95 Oct/95	LIGHTS - RADIO AND ENGINE INSTRUMENT POST E-1111, E-1241 THRU E-1666; CE-748, CE-772 THRU CE-901; CJ-149 THRU CJ-155; D-10097, D-10120 THRU D- 10342; EA-1 THRU EA-70
33-13-02	Page 1 Page 2 Page 3	Oct/95 Oct/95 Oct/95	LIGHTS - RADIO AND ENGINE INSTRUMENT POST E-1667 THRU E-1945, E-1947 THRU E-1999; CE-902 THRU CE-993; D-10343 THRU D-10391; EA-71 THRU EA-296
33-13-03	Page 1 Page 2 Page 3	Oct/95 Oct/95 Oct/95	LIGHTS - RADIO AND ENGINE INSTRUMENT POST E-2000 THRU E-2103, E-2105 THRU E-2110; CE-994 AND AFTER; CJ-156 AND AFTER; D-10392 AND AFTER; EA-297 THRU EA-319, EA-321 THRU EA-388
33-14-01	Page 1 Page 2 Page 3	Oct/95 Oct/95 Oct/95	LIGHTS - FLIGHT INSTRUMENT WEDGE (OPTIONAL) E-1111, E-1241 THRU E-1666; CE-748, CE-772 THRU CE- 901; CJ-149 THRU CJ-155; D-10097, D-10120 THRU D- 10342; EA-1 THRU EA-70
33-14-02	Page 1 Page 2 Page 3	Oct/95 Oct/95 Oct/95	LIGHTS - FLIGHT INSTRUMENT WEDGE (OPTIONAL) E-1667 THRU E-1945, E-1947 THRU E-1999; CE-902 THRU CE-993; D-10343 THRU D-10391; EA-71 THRU EA-296
33-14-03	Page 1 Page 2 Page 3	Oct/95 Oct/95 Oct/95	LIGHTS - FLIGHT INSTRUMENT WEDGE (OPTIONAL) E-2000 THRU E-2103, E-2105 THRU E-2110; CE-994 AND AFTER; CJ-156 AND AFER; D-10392 AND AFTER; EA-297 THRU EA-319, EA-321 THRU EA-388
33-15-01	Page 1 Page 2 Page 3 Page 4 Page 5	01/29/99 01/29/99 01/29/99 01/29/99 01/29/99	LIGHTS - DIMMING E-1111, E-1241 THRU E-1616; CE-748, CE-772 THRU CE- 906; CJ-149 THRU CJ-160; D-10097, D-10120 THRU D- 10321; EA-1 THRU EA-45
33-15-02	Page 1 Page 2 Page 3 Page 4 Page 5	01/29/99 01/29/99 01/29/99 01/29/99 01/29/99	LIGHTS - DIMMING E-1617 THRU E-1945, E-1947 THRU E-2103, E-2105 THRU E-2110; CE-907 AND AFTER; CJ-161 AND AFTER; D-10322 AND AFTER; EA-46 THRU EA-319, EA-321 THRU EA-388
33-16-01	Page 1 Page 2 Page 3 Page 4 Page 5	Oct/95 Oct/95 Oct/95 Oct/95 Oct/95	LIGHTS - ELECTROLUMINOUS PANEL E-1111, E-1241 THRU E-1945, E-1947 THRU E-2103, E-2105 THRU E-2110; CE-748, CE-772 AND AFTER; CJ-149 AND AFTER; D-10097, D-10120 AND AFTER; EA-1 THRU EA-319, EA-321 THRU EA-388
33-17-01	Page 1 Page 2 Page 3 Page 4 Page 5	Oct/95 Oct/95 Oct/95 Oct/95 Oct/95	LIGHTS - FLIGHT INSTRUMENTS POST (OPTIONAL) E-1111, E-1241 THRU E-1666; CE-748, CE-772 THRU CE- 901; CJ-149 THRU CJ-155; D-10097, D-10120 THRU D- 10342; EA-1 THRU EA-70

Raytheon Aircraft

BEECH BONANZA WIRING DIAGRAM MANUAL

LIST OF PAGES & TABLE OF CONTENTS (Continued)

for

CHAPTER 33 - LIGHTS

SYS/SUB-SYS/ CHAP SECTION	PAGE NO.	EFFECTIVE DATE	TABLE OF CONTENTS
33-17-02	Page 1	Oct/95	LIGHTS - FLIGHT INSTRUMENTS POST (OPTIONAL) E-1667 THRU E-1945, E-1947 THRU E-1999; CE-902 THRU CE-993; D-10343 THRU D-10391; EA-71 THRU EA-296
	Page 2	Oct/95	
	Page 3	Oct/95	
	Page 4	Oct/95	
	Page 5	Oct/95	
33-17-03	Page 1	Oct/95	LIGHTS - FLIGHT INSTRUMENTS POST (OPTIONAL) E-2000 THRU E-2103, E-2105 THRU E-2110; CE-994 AND AFTER; CJ-156 AND AFTER; D-10392 AND AFTER; EA-297 THRU EA-319, EA-321 THRU EA-388
	Page 2	Oct/95	
	Page 3	Oct/95	
33-18-01 (Config 1)	Page 1	Oct/95	LIGHTS - FLOOD E-1111, E-1241 THRU E-1945, E-1947 THRU E-2103, E-2105 THRU E-2110; CE-748, CE-772 THRU CE-1300, CE-1302 THRU CE-1306; CJ-149 THRU CJ-179; D-10097, D-10120 AND AFTER; EA-1 THRU EA-319, EA-321 THRU EA-388
	Page 2	Oct/95	
	Page 3	Oct/95	
	Page 4	Oct/95	
	Page 5	Oct/95	
33-18-01 (Config 2)	Page 1	Oct/95	LIGHTS - FLOOD CE-1301, CE-1307 AND AFTER; CJ-180 AND AFTER
	Page 2	Oct/95	
	Page 3	Oct/95	
	Page 4	Oct/95	
	Page 5	Oct/95	
33-20-01	Page 1	Oct/95	LIGHTS - CABIN E-1111, E-1241 THRU E-1421, E-1423 THRU E-1550, E-1552 THRU E-1568, E-1570 THRU E-1580, E-1582 THRU E-1593; CE-748, CE-772 THRU CE-918, CE-920 THRU CE-922, CE-924, CE-926, CE-928; CJ-149 THRU CJ-155; D-10097, D- 10120 THRU D-10347, D-10349 THRU D-10352; EA-1 THRU EA-20, EA-22 THRU EA-27, EA-29 THRU EA-32
	Page 2	Oct/95	
	Page 3	Oct/95	
33-20-02	Page 1	Oct/95	LIGHTS - CABIN E-1422, E-1551, E-1569, E-1594 THRU E-1945, E-1947 THRU E-2103, E-2105 THRU E-2110; CE-919, CE-923, CE-925, CE- 927, CE-929 AND AFTER; CJ-156 AND AFTER; D-10348, D-10353 AND AFTER; EA-33 THRU EA-319, EA-321 THRU EA-388
	Page 2	Oct/95	
	Page 3	Oct/95	
33-40-01	Page 1	Oct/95	LIGHTS - THREE LIGHT STROBE (OPTIONAL) E-1111, E-1241 THRU E-1470; CE-748, CE-772 THRU CE- 850; CJ-149 ONLY; D-10097, D-10120 THRU D-10241; EA-1 THRU EA-3
	Page 2	Oct/95	
	Page 3	Oct/95	
	Page 4	Oct/95	
	Page 5	Oct/95	
33-40-02 (Config 1)	Page 1	Oct/95	LIGHTS - THREE LIGHT STROBE (OPTIONAL) E-1471 THRU E-1945, E-1947 THRU E-2103, E-2105 THRU E-2110; CE-851 THRU CE-1164; CJ-150 THRU CJ-179; D-10242 AND AFTER; EA-4 THRU EA-319, EA-321 THRU EA-388
	Page 2	Oct/95	
	Page 3	Oct/95	
	Page 4	Oct/95	
	Page 5	Oct/95	

Raytheon Aircraft

BEECH BONANZA WIRING DIAGRAM MANUAL

LIST OF PAGES & TABLE OF CONTENTS (Continued)
for
CHAPTER 33 - LIGHTS

SYS/SUB-SYS/ CHAP SECTION	PAGE NO.	EFFECTIVE DATE	TABLE OF CONTENTS
33-40-02 (Config 2)	Page 1 Page 2 Page 3 Page 4 Page 5	Oct/95 Oct/95 Oct/95 Oct/95 Oct/95	LIGHTS - THREE LIGHT STROBE (OPTIONAL) CE-1165 AND AFTER; CJ-180 AND AFTER
33-42-01	Page 1 Page 2 Page 3	Oct/95 Oct/95 Oct/95	LIGHTS - COURTESY (OPTIONAL) E-1111, E-1241 THRU E-1945, E-1947 THRU E-2103, E-2105 THRU E-2110; CE-748, CE-772 AND AFTER; D-10097, D- 10120 AND AFTER; EA-1 THRU EA-319, EA-321 THRU EA- 388
33-43-01	Page 1 Page 2 Page 3	Oct/95 Oct/95 Oct/95	LIGHTS - TAXI E-1111, E-1241 THRU E-1945, E-1947 THRU E-2103, E-2105 THRU E-2110; CE-748, CE-772 AND AFTER; CJ-149 AND AFTER; D-10097, D-10120 AND AFTER; EA-1 THRU EA-319, EA-321 THRU EA-388
33-44-01	Page 1 Page 2 Page 3	Oct/95 Oct/95 Oct/95	LIGHTS - ROTATING BEACON (OPTIONAL) E-1111, E-1241 THRU E-1551; CE-748, CE-772 THRU CE- 871; CJ-149 AND CJ-150; D-10097, D-10120 THRU D-10268; EA-1 THRU EA-11
33-44-02 (Config 1)	Page 1 Page 2 Page 3 Page 4 Page 5 Page 6 Page 7	Oct/95 Oct/95 Oct/95 Oct/95 Oct/95 Oct/95 Oct/95	LIGHTS - ROTATING BEACON (OPTIONAL) CE-872 AND AFTER; CJ-151 AND AFTER
33-44-02 (Config 2)	Page 1 Page 2 Page 3 Page 4 Page 5 Page 6 Page 7	Oct/95 Oct/95 Oct/95 Oct/95 Oct/95 Oct/95 Oct/95	LIGHTS - ROTATING BEACON (OPTIONAL) D-10269 AND AFTER
33-44-02 (Config 3)	Page 1 Page 2 Page 3 Page 4 Page 5	Oct/95 Oct/95 Oct/95 Oct/95 Oct/95	LIGHTS - ROTATING BEACON (OPTIONAL) E-1552 THRU E-1945, E-1947 THRU E-2103, E-2105 THRU E-2110; EA-12 THRU EA-319, EA-321 THRU EA-388
33-45-01 (Config 1)	Page 1 Page 2 Page 3	Oct/95 Oct/95 Oct/95	LIGHTS - NAVIGATION E-1111, E-1241 THRU E-1945, E-1947 THRU E-2103, E-2105 THRU E-2110; CE-748, CE-772 THRU CE-1664; CJ-149 THRU CJ-179; D-10097, D-10120 AND AFTER; EA-1 THRU EA-319, EA-321 THRU EA-388

Raytheon Aircraft

BEECH BONANZA WIRING DIAGRAM MANUAL

LIST OF PAGES & TABLE OF CONTENTS (Continued)
for
CHAPTER 33 - LIGHTS

SYS/SUB-SYS/ CHAP SECTION	PAGE NO.	EFFECTIVE DATE	TABLE OF CONTENTS
33-45-01 (Config 2)	Page 1	Oct/95	LIGHTS - NAVIGATION
	Page 2	Oct/95	CE-1165 AND AFTER; CJ-180 AND AFTER
	Page 3	Oct/95	
33-46-01	Page 1	Oct/95	LIGHTS - LANDING
	Page 2	Oct/95	E-1111, E-1241 THRU E-1945, E-1947 THRU E-2103, E-2105
	Page 3	Oct/95	THRU E-2110; CE-748, CE-772 AND AFTER; CJ-149 AND AFTER; D-10097, D-10120 AND AFTER; EA-1 THRU EA-319, EA-321 THRU EA-388

Beechcraft
BONANZA
WIRING DIAGRAM MANUAL

33-10-01

**E-1111, E-1241 THRU E-1765; CE-748, CE-722 THRU CE-918, CE-920
THRU CE-922, CE-924, CE-926, CE-928; CJ-149 THRU CJ-155;
D-10097, D-10120 THRU D-10353; EA-1 THRU EA-158**

Beechcraft BONANZA WIRING DIAGRAM MANUAL

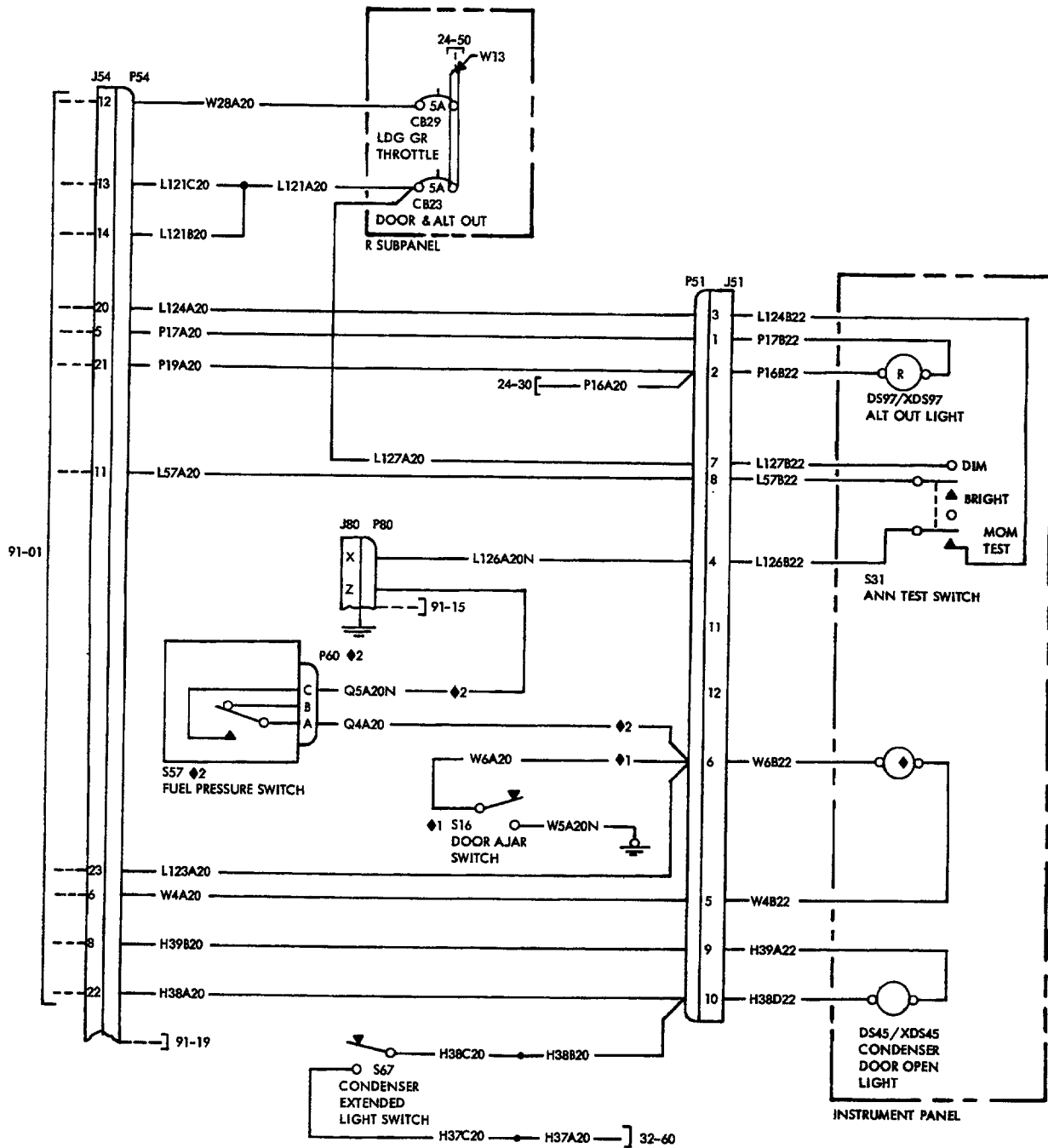

- ◆ ON AIRCRAFT E-1111, E-1241 THRU E-1765;
DS47/XDS47 - DOOR AJAR LIGHT.
ON AIRCRAFT CJ-149 THRU CJ-155,
DS121/XDS121 - FUEL PRESSURE LIGHT.
- ◆1 ON AIRCRAFT E-1111, E-1241 THRU E-1765; EA-1 THRU EA-158
WIRE W6A20 & S16 SWITCH ARE USED AS SHOWN.
- ◆2 ON AIRCRAFT CJ-149 THRU CJ-155
WIRE Q4A20, Q5A20N, PLUG P60 & S57
SWITCH ARE USED AS SHOWN.

LIGHTS-ANNUNCIATOR, FLIGHT COMPARTMENT

Beechcraft
BONANZA
WIRING DIAGRAM MANUAL

REFERENCE DESIGNATOR	PART NUMBER	DESCRIPTION	USABLE	
			INSTL ZONE	ON CODE
33-10-01				
CB23	435-205-104	CIRCUIT BREAKER-DOOR AND ALTERNATOR OUT	240	2
CB23	7277-2-5	CIRCUIT BREAKER-DOOR AND ALTERNATOR OUT	240	3
CB29	435-205-104	CIRCUIT BREAKER-LANDING GEAR THROTTLE	240	2
CB29	7277-2-5	CIRCUIT BREAKER-LANDING GEAR THROTTLE	240	3
DS45	327	WARNING LIGHT-CONDENSER DOOR	240	1
DS97	327	BULB-ALTERNATOR OUT WARNING LIGHT	240	1
J51A	1-480288-0	RECEPTACLE-ANNUNCIATOR LIGHT	240	1
J51B	60618-1	PIN CONTACT	240	1
J54A	206151-2	RECEPTACLE-JUNCTION BOX ASSEMBLY	231	5
J54A	206152-1	RECEPTACLE-JUNCTION BOX ASSEMBLY	231	4
J54B	206138-1	STRAIN RELIEF	231	5
J54B	1-205202-6	PIN CONTACT	231	4
J54C	66103-2	PIN CONTACT	231	5
J54C	206070-1	STRAIN RELIEF CLAMP	231	4
J80	204814-1	RECEPTACLE-GROUNDING BLOCK	231	1
P51A	1-480287-0	PLUG-ANNUNCIATOR LIGHT	240	1
P51B	60617-1	SOCKET CONTACT	240	1
P54A	206150-1	PLUG-JUNCTION BOX ASSEMBLY	231	5
P54A	205839-3	PLUG-JUNCTION BOX ASSEMBLY	231	4
P54B	206138-1	STRAIN RELIEF	231	5
P54B	205089-1	SOCKET CONTACT	231	4
P54C	66105-2	SOCKET CONTACT	231	5
P60	MS3106A/B10SL3S	PLUG-FUEL PRESSURE SWITCH (SUPERSEDED BY 132325 10SL-3S)	240	1
P80A	200838-3	PLUG-GROUNDING BLOCK	231	1
P80B	201224-1	STRAIN RELIEF	231	1
P80C	201328-1	SOCKET CONTACT	231	1
P80D	200333-1	SOCKET CONTACT	231	1
P80E	203618-1	JACKSCREW	231	1
S16	MS25026-1	SWITCH-DOOR AJAR	830	1
S31	MST-205T	SWITCH-ANNUNCIATOR TEST	240	8
S31	8858K40	SWITCH-ANNUNCIATOR TEST	240	7
S31	8858K82	SWITCH-ANNUNCIATOR TEST	240	6
S57	60-389012-9	SWITCH-FUEL PRESSURE	140	1
S67	MS25026-1	SWITCH-CONDENSER EXTENDED LIGHT	150	1
XDS45	855291SIR2DS-P6	LAMPHOLDER-CONDENSER DOOR OPEN WARNING	240	1

Beechcraft BONANZA WIRING DIAGRAM MANUAL

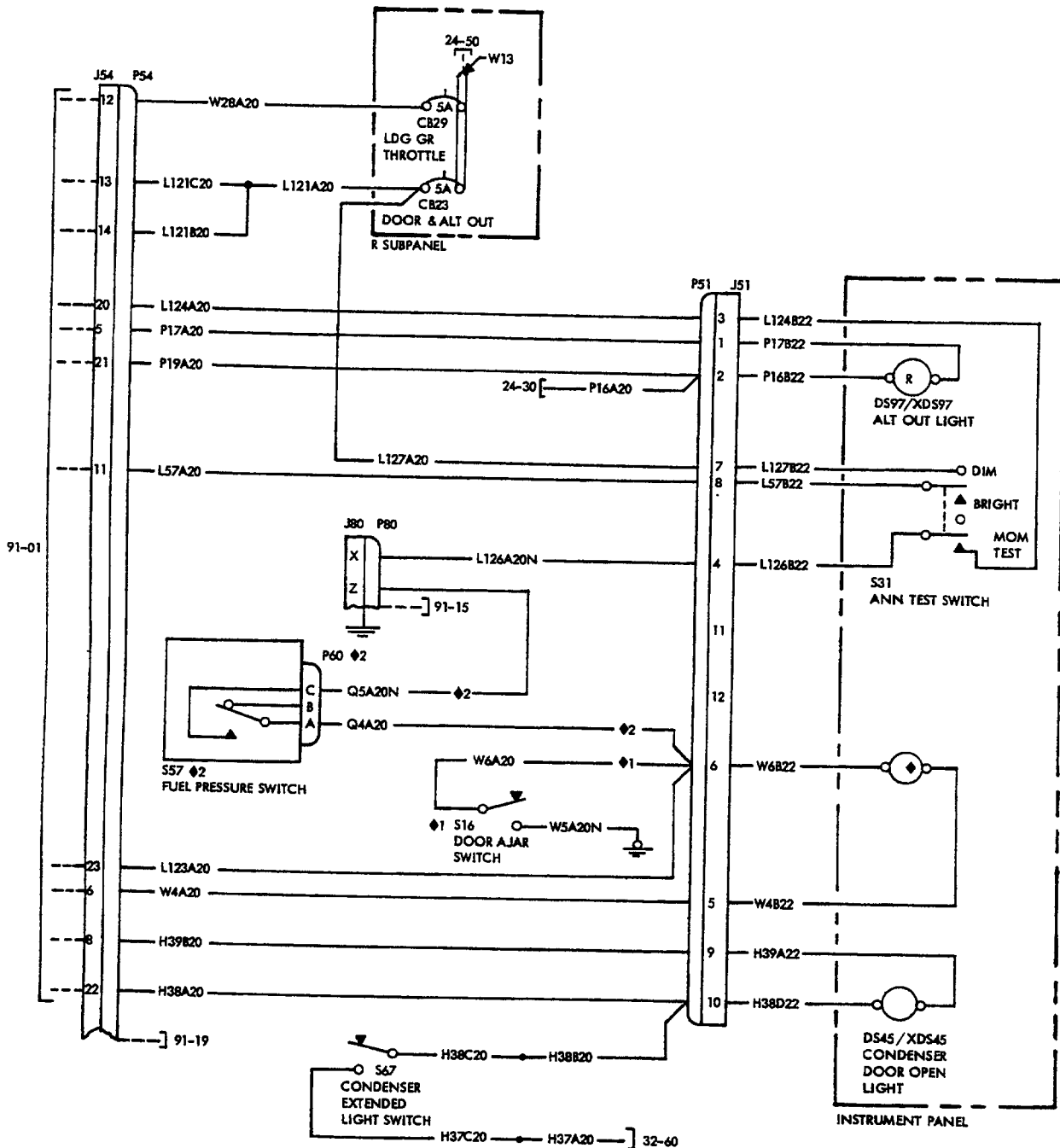

◆ ON AIRCRAFT E-1111, E-1241 THRU E-1765;
DS47/XDS47 - DOOR AJAR LIGHT.
ON AIRCRAFT CJ-149 THRU CJ-155.
DS121/XDS121 - FUEL PRESSURE LIGHT.

◆1 ON AIRCRAFT E-1111, E-1241 THRU E-1765; EA-1 THRU EA-158
WIRE W6A20 & S16 SWITCH ARE USED AS SHOWN.

◆2 ON AIRCRAFT CJ-149 THRU CJ-155
WIRE Q4A20, Q5A20N, PLUG P60 & S57
SWITCH ARE USED AS SHOWN.

LIGHTS-ANNUNCIATOR, FLIGHT COMPARTMENT

Beechcraft
BONANZA
WIRING DIAGRAM MANUAL

REFERENCE DESIGNATOR	PART NUMBER	DESCRIPTION	USABLE INSTL ON ZONE CODE
33-10-01			
XDS97	855291SIR2DS-P6	LAMPHOLDER-ALTERNATOR OUT WARNING LIGHT	240 1

EFFECTIVITY CODE

1. E-1111, E-1241 THRU E-1765; CE-748, CE-772 THRU CE-918, CE-920 THRU CE-922, CE-924, CE-926, CE-928; CJ-149 THRU CJ-155; D-10097, D-10120 THRU D-10353; EA-1 THRU EA-158
2. E-1111, E-1241 THRU E-1765; CE-748, CE-772 THRU CE-918, CE-920 THRU CE-922, CE-924, CE-926, CE-928; CJ-149 THRU CJ-155; D-10097, D-10120 THRU D-10347, D-10349 THRU D-10353; EA-1 THRU EA-158
3. D-10348 ONLY
4. E-1111, E-1241 THRU E-1370; CE-748, CE-772 THRU CE-815; D-10097, D-10120 THRU D-10178; EA-1 ONLY
5. E-1371 THRU E-1765; CE-816 THRU CE-918, CE-920 THRU CE-922, CE-924, CE-926, CE-928; CJ-149 THRU CJ-155; D-10179 THRU D-10353; EA-2 THRU EA-158
6. E-1371 THRU E-1765; CE-816 THRU CE-918, CE-920 THRU CE-922, CE-924, CE-926, CE-928; CJ-150 THRU CJ-155; D-10179 THRU D-10353; EA-1 THRU EA-158
7. E-1111, E-1241 THRU E-1370; CE-815 ONLY; CJ-149 ONLY; D-10178 ONLY
8. CE-748, CE-772 THRU CE-814; D-10097, D-10120 THRU D-10177

Beechcraft
BONANZA
WIRING DIAGRAM MANUAL

33-10-02

Configuration 1

**E-1766 THRU E-1945, E-1947 THRU E-2103, E-2105 THRU E-2110;
CE-919, CE-923, CE-925, CE-927, CE-929 THRU CE-1055; D-10354
THRU D-10403; EA-159 THRU EA-319, EA-321 THRU EA-388**

Beechcraft BONANZA WIRING DIAGRAM MANUAL

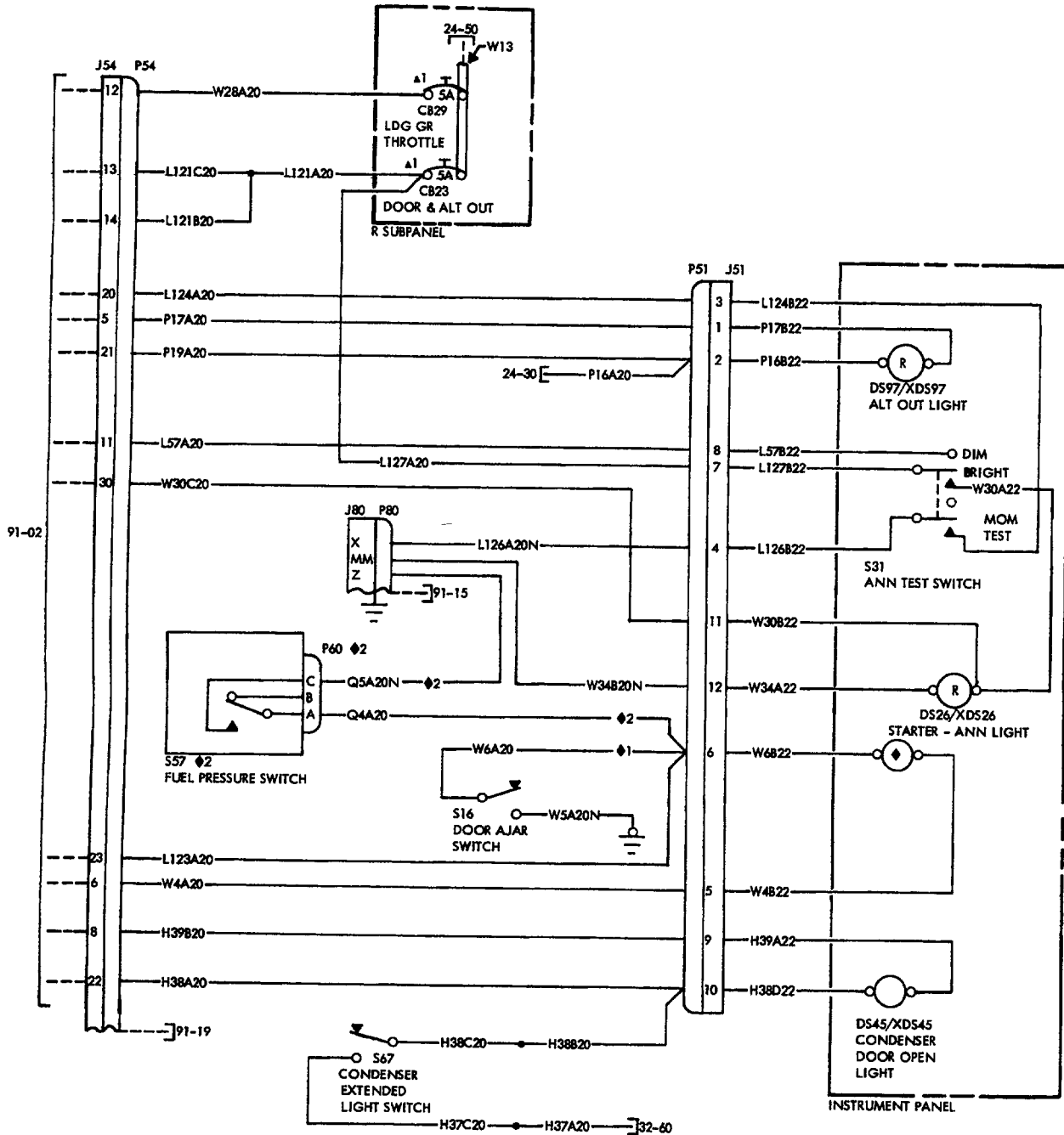

◆ ON AIRCRAFT E-1776 & AFTER:
DS47/XDS47 - DOOR AJAR LIGHT,
ON AIRCRAFT CJ-156 & AFTER:
DS121/XDS121 - FUEL PRESSURE LIGHT.

◆1 ON AIRCRAFT E-1766 & AFTER; EA-159
& AFTER; WIRE W6A20 & S16 SWITCH
ARE USED AS SHOWN.

◆2 ON AIRCRAFT CJ-156 & AFTER:
WIRE Q4A20, Q5A20N; PLUG
P60 & S57 SWITCH ARE USED AS SHOWN.

LIGHTS-ANNUNCIATOR TEST, FLIGHT COMPARTMENT (Configuration 1)

Beechcraft
BONANZA
WIRING DIAGRAM MANUAL

REFERENCE DESIGNATOR	PART NUMBER	DESCRIPTION	INSTL ZONE	USABLE ON CODE
33-10-02 (Configuration 1)				
CB23	435-205-104	CIRCUIT BREAKER-DOOR AND ALTERNATOR OUT	240	3
CB23	7277-2-5	CIRCUIT BREAKER-DOOR AND ALTERNATOR OUT	240	2
CB29	435-205-104	CIRCUIT BREAKER-LANDING GEAR THROTTLE	240	3
CB29	7277-2-5	CIRCUIT BREAKER-LANDING GEAR THROTTLE	240	2
DS26	327	LIGHT-START ANNUNCIATOR	240	1
DS45	327	WARNING LIGHT-CONDENSER DOOR	240	1
DS97	327	BULB-ALTERNATOR OUT WARNING LIGHT	240	1
J51A	1-480288-0	RECEPTACLE-ANNUNCIATOR LIGHT	240	1
J51B	60618-1	PIN CONTACT	240	1
J54A	206151-2	RECEPTACLE-JUNCTION BOX ASSEMBLY	231	1
J54B	206138-1	STRAIN RELIEF	231	1
J54C	66103-2	PIN CONTACT	231	1
J80	204814-1	RECEPTACLE-GROUNDING BLOCK	231	1
P51A	1-480287-0	PLUG-ANNUNCIATOR LIGHT	240	1
P51B	60617-1	SOCKET CONTACT	240	1
P54A	206150-1	PLUG-JUNCTION BOX ASSEMBLY	231	1
P54B	206138-1	STRAIN RELIEF	231	1
P54C	66105-2	SOCKET CONTACT	231	1
P60	MS3106A/B10SL3S	PLUG-FUEL PRESSURE SWITCH (SUPERSEDED BY 132325 10SL-3S)	240	1
P80A	200838-3	PLUG-GROUNDING BLOCK	231	1
P80B	201224-1	STRAIN RELIEF	231	1
P80C	201328-1	SOCKET CONTACT	231	1
P80D	200333-1	SOCKET CONTACT	231	1
P80E	203618-1	JACKSCREW	231	1
S16	MS25026-1	SWITCH-DOOR AJAR	830	1
S31	8858K82	SWITCH-ANNUNCIATOR TEST	240	1
S57	60-389012-9	SWITCH-FUEL PRESSURE	140	1
S67	MS25026-1	SWITCH-CONDENSER EXTENDED LIGHT	150	1
W13	114931-1-12	BUS-MAIN	240	1
XDS26	855291S1R2DSP6	LAMPHOLDER-START ANNUNCIATOR	240	1
XDS45	855291S1R2DSP6	LAMPHOLDER-CONDENSER DOOR OPEN WARNING	240	1
XDS97	855291S1R2DSP6	LAMPHOLDER-ALTERNATOR OUT WARNING LIGHT	240	1

EFFECTIVITY CODE

1. E-1766 THRU E-1945, E-1947 THRU E-2103, E-2105 THRU E-2110; CE-919, CE-923, CE-925, CE-927, CE-929 THRU CE-1055; D-10354 THRU D-10403; EA-159 THRU EA-319, EA-321 THRU EA-388

2. E-1766 THRU E-1945, E-1947 THRU E-2103, E-2105 THRU E-2110; CE-919, CE-929 THRU CE-1055; D-10354 THRU D-10403; EA-159 THRU EA-319, EA-321 THRU EA-388

3. CE-923, CE-925, CE-927

Beechcraft
BONANZA
WIRING DIAGRAM MANUAL

33-10-02

Configuration 2

**CE-1056 THRU CE-1300, CE-1302 THRU CE-1306; CJ-156 THRU
CJ-179; D-10404 AND AFTER**

Beechcraft BONANZA WIRING DIAGRAM MANUAL

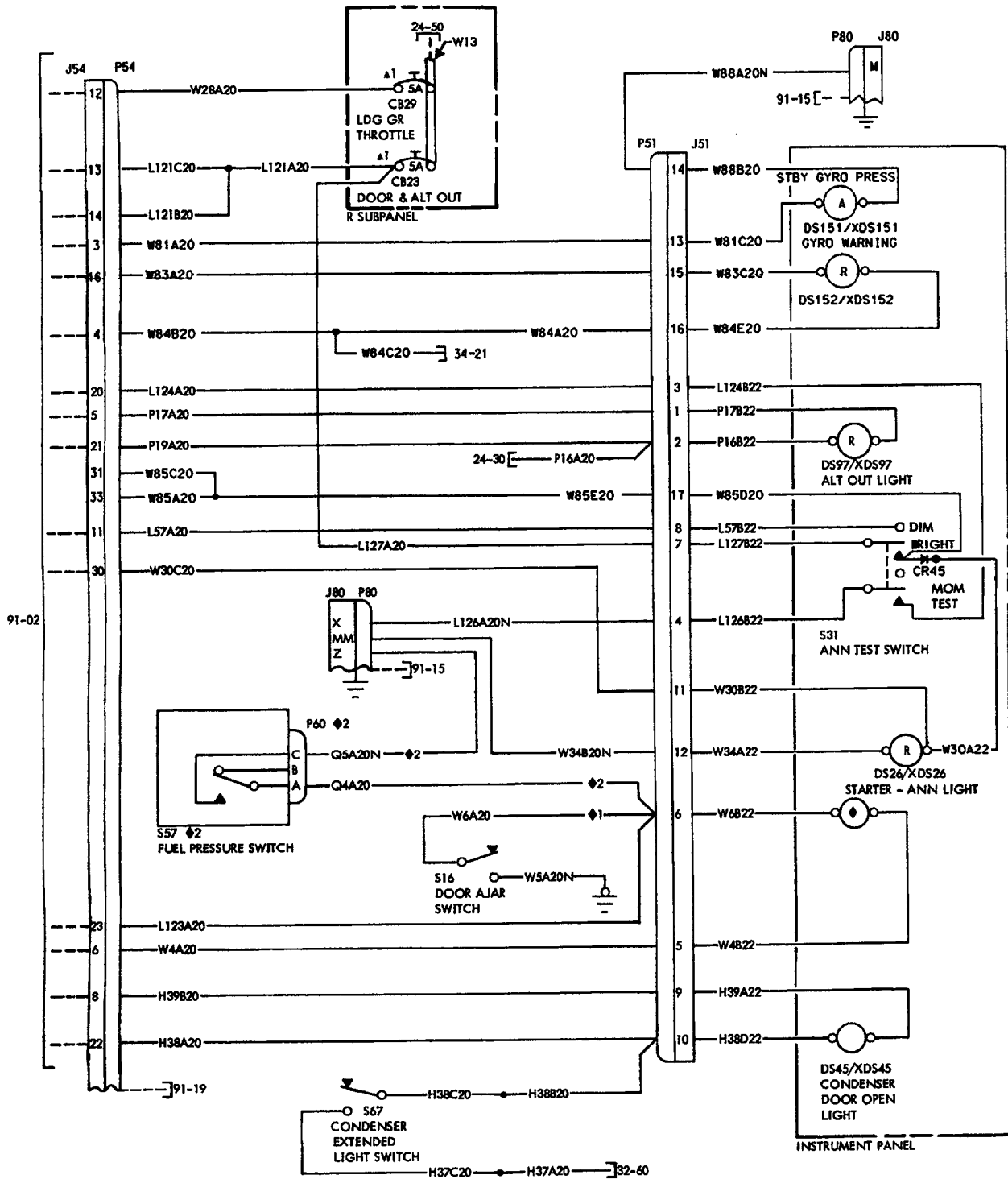

◆ ON AIRCRAFT E-1776 & AFTER:
DS47/XDS47 - DOOR AJAR LIGHT.
ON AIRCRAFT CJ-156 & AFTER:
DS121/XDS121 - FUEL PRESSURE LIGHT.

◆ ON AIRCRAFT E-1766 & AFTER; EA-159
& AFTER; WIRE W6A20 & S16 SWITCH
ARE USED AS SHOWN.

◆ ON AIRCRAFT CJ-156 & AFTER:
WIRE Q4A20, Q5A20N; PLUG
P60 & S57 SWITCH ARE USED AS SHOWN.

LIGHTS-ANNUNCIATOR TEST, FLIGHT COMPARTMENT (Configuration 2)

Raytheon Aircraft

BEECH BONANZA WIRING DIAGRAM MANUAL

REFERENCE DESIGNATOR	PART NUMBER	DESCRIPTION	INSTL ZONE	USABLE ON CODE
33-10-02 (Configuration 2)				
CB23	7277-2-5	CIRCUIT BREAKER-DOOR AND ALTERNATOR OUT	240	1
CB29	7277-2-5	CIRCUIT BREAKER-LANDING GEAR THROTTLE	240	1
CR45	1N4007	DIODE-STANDBY AIR PRESSURE (SUPERSEDED BY 132408-22)	240	1
CR45	132408-22	DIODE-STANDBY AIR PRESSURE (SUPERSEDES 1N4007)	240	1
DS151	327	LAMP	240	1
DS152	327	LAMP	240	1
DS26	327	LIGHT-START ANNUNCIATOR	240	1
DS45	327	WARNING LIGHT-CONDENSER DOOR	240	1
DS97	327	BULB-ALTERNATOR OUT WARNING LIGHT	240	1
J51A	1-480288-0	RECEPTACLE-ANNUNCIATOR LIGHT	240	1
J51B	60618-1	PIN CONTACT	240	1
J54A	206151-2	RECEPTACLE-JUNCTION BOX ASSEMBLY	231	1
J54B	206138-1	STRAIN RELIEF	231	1
J54C	66103-2	PIN CONTACT	231	1
J80	204814-1	RECEPTACLE-GROUNDING BLOCK	231	1
P51A	1-480287-0	PLUG-ANNUNCIATOR LIGHT	240	1
P51B	60617-1	SOCKET CONTACT	240	1
P54A	206150-1	PLUG-JUNCTION BOX ASSEMBLY	231	1
P54B	206138-1	STRAIN RELIEF	231	1
P54C	66105-2	SOCKET CONTACT	231	1
P60	MS3106A/B10SL3S	PLUG-FUEL PRESSURE SWITCH (SUPERSEDED BY 132325 10SL-3S)	240	1
P80A	200838-3	PLUG-GROUNDING BLOCK	231	1
P80B	201224-1	STRAIN RELIEF	231	1
P80C	201328-1	SOCKET CONTACT	231	1
P80D	200333-1	SOCKET CONTACT	231	1
P80E	203618-1	JACKSCREW	231	1
S16	MS25026-1	SWITCH-DOOR AJAR	830	1
S31	8858K82	SWITCH-ANNUNCIATOR TEST	240	1
S57	60-389012-9	SWITCH-FUEL PRESSURE	140	1
S67	MS25026-1	SWITCH-CONDENSER EXTENDED LIGHT	150	1
W13	114931-1-12	BUS-MAIN	240	1
XDS151	855291SIA4DSP6	LAMPHOLDER-STANDBY GYRO PRESSURE	240	1
XDS152	855291SI-2-DS-P6	LAMPHOLDER-GYRO WARNING	240	1
XDS26	855291SI-2-DS-P6	LAMPHOLDER-START ANNUNCIATOR	240	1
XDS45	855291SI-2-DS-P6	LAMPHOLDER-CONDENSER DOOR OPEN WARNING	240	1
XDS97	855291SI-2-DS-P6	LAMPHOLDER-ALTERNATOR OUT WARNING LIGHT	240	1

CODES OF EFFECTIVITY

1. CE-1056 THRU CE-1300, CE-1302 THRU CE-1306; CJ-156 THRU CJ-179; D-10404 AND AFTER

Beechcraft
BONANZA
WIRING DIAGRAM MANUAL

33-10-02

Configuration 3

CE-1301, CE-1307 AND AFTER; CJ-180 AND AFTER

Beechcraft BONANZA WIRING DIAGRAM MANUAL

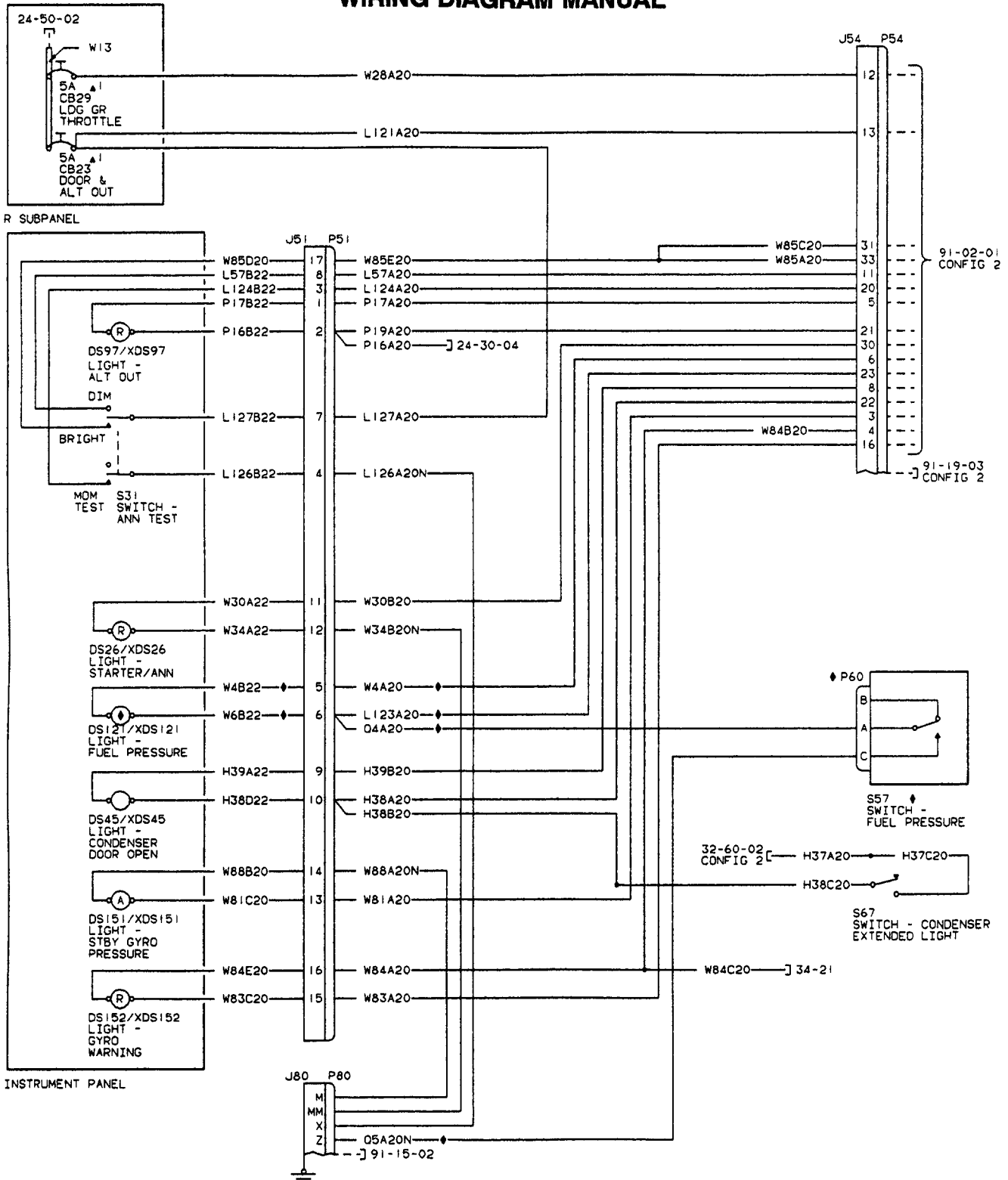

◆ DS121/XDS121 FUEL PRESSURE LIGHT, S57 SWITCH, P60 PLUG & ASSOCIATE WIRING USED ONLY ON CJ TYPE AIRCRAFT.

LIGHTS-ANNUNCIATOR TEST, FLIGHT COMPARTMENT (Configuration 3)

Beechcraft
BONANZA
WIRING DIAGRAM MANUAL

REFERENCE DESIGNATOR	PART NUMBER	DESCRIPTION	USABLE	
			INSTL ZONE	ON CODE
33-10-02 (Configuration 3)				
CB23	7277-2-5	CIRCUIT BREAKER-DOOR AND ALTERNATOR OUT	240	1
CB29	7277-2-5	CIRCUIT BREAKER-LANDING GEAR THROTTLE	240	1
DS121	327	POST LIGHT-FUEL PRESSURE	240	2
DS151	327	LAMP	240	1
DS152	327	LAMP	240	1
DS26	327	LIGHT-START ANNUNCIATOR	240	1
DS45	327	WARNING LIGHT-CONDENSER DOOR	240	1
DS97	327	BULB-ALTERNATOR OUT WARNING LIGHT	240	1
J51A	1-480288-0	RECEPTACLE-ANNUNCIATOR LIGHT	240	1
J51B	60618-1	PIN CONTACT	240	1
J54A	206151-2	RECEPTACLE-JUNCTION BOX ASSEMBLY	231	1
J54B	206138-1	STRAIN RELIEF	231	1
J54C	66103-2	PIN CONTACT	231	1
J80	204814-1	RECEPTACLE-GROUNDING BLOCK	231	1
P51A	1-480287-0	PLUG-ANNUNCIATOR LIGHT	240	1
P51B	60617-1	SOCKET CONTACT	240	1
P54A	206150-1	PLUG-JUNCTION BOX ASSEMBLY	231	1
P54B	206138-1	STRAIN RELIEF	231	1
P54C	66105-2	SOCKET CONTACT	231	1
P60	MS3106A/B10SL3S	PLUG-FUEL PRESSURE SWITCH (SUPERSEDED BY 132325 10SL-3S)	240	1
P80A	200838-3	PLUG-GROUNDING BLOCK	231	1
P80B	201224-1	STRAIN RELIEF	231	1
P80C	201328-1	SOCKET CONTACT	231	1
P80D	200333-1	SOCKET CONTACT	231	1
P80E	203618-1	JACKSCREW	231	1
S31	8858K82	SWITCH-ANNUNCIATOR TEST	240	1
S57	60-389012-9	SWITCH-FUEL PRESSURE	140	1
S67	MS25026-1	SWITCH-CONDENSER EXTENDED LIGHT	150	1
W13	114931-1-12	BUS-MAIN	240	1
XDS121	855291SI-G-5-DS-P6	LAMPHOLDER-FUEL PRESSURE	240	1
XDS151	855291SI-A-4-DS-P6	LAMPHOLDER-STANDBY GYRO PRESSURE	240	1
XDS152	855291SI-R-2-DS-P6	LAMPHOLDER-GYRO WARNING	240	1
XDS26	855291SI-R-2-DS-P6	LAMPHOLDER-START ANNUNCIATOR	240	1
XDS45	855291SI-R-2-DS-P6	LAMPHOLDER-CONDENSER DOOR OPEN WARNING	240	1
XDS97	855291SI-R-2-DS-P6	LAMPHOLDER-ALTERNATOR OUT WARNING LIGHT	240	1

EFFECTIVITY CODE

1. CE-1301, CE-1307 AND AFTER; CJ-180 AND AFTER
2. CJ-180 AND AFTER

Beechcraft
BONANZA
WIRING DIAGRAM MANUAL

33-11-01

**E-1111, E-1241 THRU E-1517; CE-748, CE-772 THRU CE-861; CJ-149
ONLY; D-10097, D-10120 THRU D-10247; EA-1 THRU EA-5**

Beechcraft BONANZA WIRING DIAGRAM MANUAL

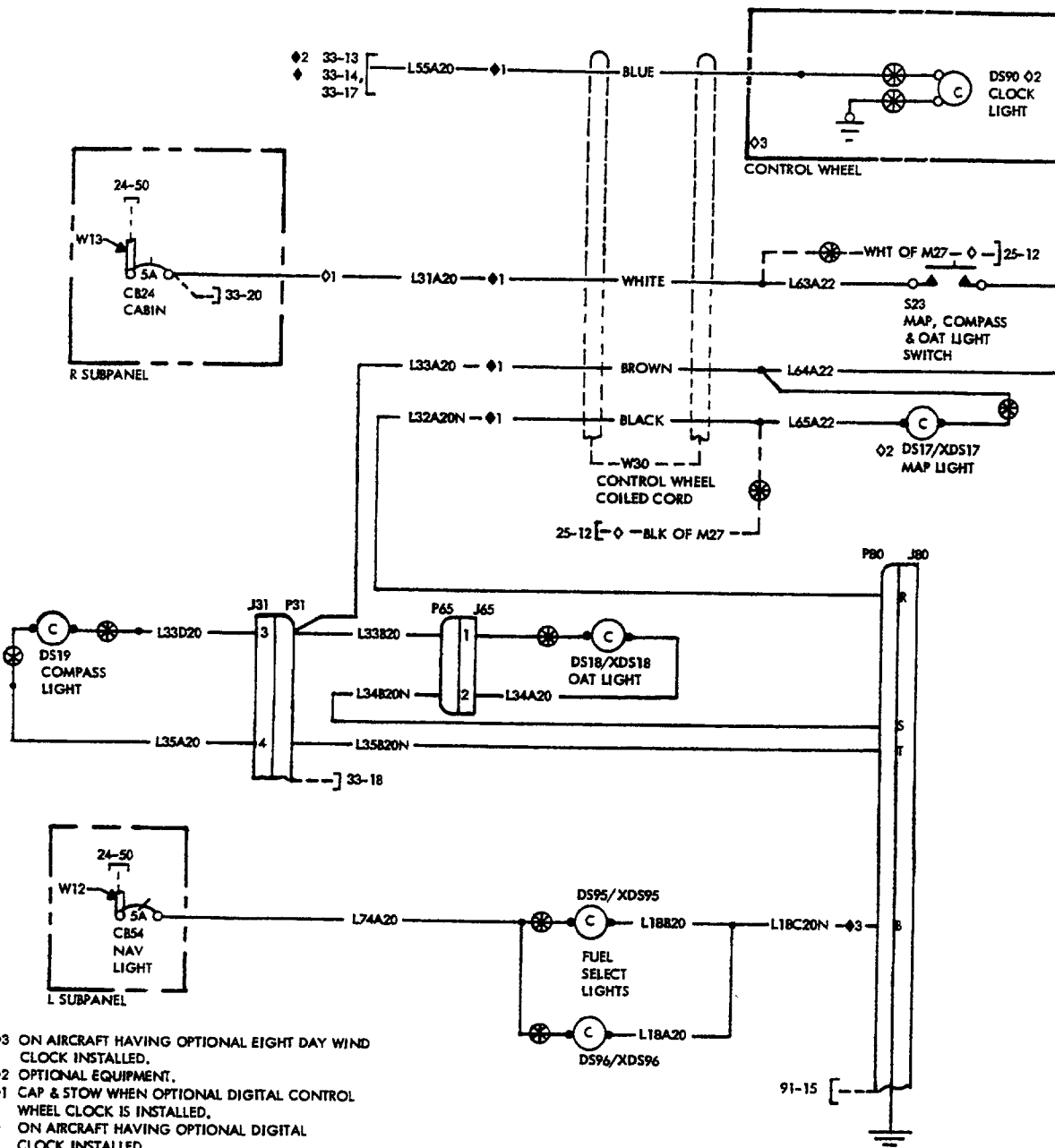

- ◆ ON AIRCRAFT HAVING OPTIONAL EIGHT DAY WIND CLOCK INSTALLED.
 - ◆ ON AIRCRAFT WITH OPTIONAL WEDGE LIGHTS REF 33-74.
 - ◆ ON AIRCRAFT WITH OPTIONAL POST LIGHTS REF 33-17.
 - ◆ ON AIRCRAFT W/O OPTIONAL WEDGE LIGHTS OR POST LIGHTS.
- ◆ ON AIRCRAFT HAVING OPTIONAL DIGITAL CONTROL WHEEL CLOCK IS INSTALLED.
 ◆ ON AIRCRAFT HAVING OPTIONAL DIGITAL CLOCK INSTALLED.
- ◆ FOR MODE OF CONNECTION TO COILED CORD, REFER TO APPLICABLE AVIONICS DWG.
- ◆ WIRE L18C MAY TERMINATE IN PIN B OR ANY OPEN PIN ON CONN P/J80.

LIGHTS-MAP, COMPASS, OAT AND FUEL SELECT

Deechcraft
BONANZA
WIRING DIAGRAM MANUAL

REFERENCE DESIGNATOR	PART NUMBER	DESCRIPTION	USABLE INSTL ON ZONE CODE
33-11-01			
CB24	435-205-104	CIRCUIT BREAKER-CABIN AND MAP LIGHT	240 1
CB54	35-380132-41	CIRCUIT BREAKER-NAVIGATION LIGHT	240 1
DS17	1495	LIGHT-MAP (OPTL)	240 1
DS18	MS25237-327	POST LIGHT-OUTSIDE AIR TEMPERATURE	251 1
DS19	327	LIGHT-COMPASS	240 1
DS90	267	LIGHT-CLOCK, CONTROL WHEEL (OPTL)	240 1
DS95	327	POST LIGHT-FUEL SELECT (OPTL)	240 1
DS96	327	POST LIGHT-FUEL SELECT	240 1
J31A	1-480340-0	RECEPTACLE-GLARESHIELD	231 1
J31B	1-480345-0	PIN HOUSING	231 1
J31C	60618-1	PIN CONTACT	231 1
J65A	1-480319-0	RECEPTACLE-OUTSIDE AIR TEMPERATURE (OAT)	251 1
J65B	60617-1	SOCKET CONTACT	251 1
J80	204814-1	RECEPTACLE-GROUNDING BLOCK	231 1
P31A	1-480270-0	PLUG-GLARESHIELD	231 1
P31B	1-480283-0	SOCKET HOUSING	231 1
P31C	60617-1	SOCKET CONTACT	231 1
P65A	1-480318-0	PLUG-OUTSIDE AIR TEMPERATURE LIGHT	251 1
P65B	60618-1	PIN CONTACT	251 1
P80A	200838-3	PLUG-GROUNDING BLOCK	231 1
P80B	201224-1	STRAIN RELIEF	231 1
P80C	201328-1	SOCKET CONTACT	231 1
P80D	200333-1	SOCKET CONTACT	231 1
P80E	203618-1	JACKSCREW	231 1
S23	L18366-5	SWITCH-MAP, COMPASS, OAT LIGHT	240 1
W12	114931-1-6	BUS LIGHT	240 1
W13	114931-1-12	BUS-MAIN	240 1
W30	101-384082-3	COILED CORD	240 1
XDS17	96-364090-11	LAMPHOLDER-MAP LIGHT (OPTL)	240 1
XDS18	A6745B	LAMPHOLDER-OUTSIDE AIR TEMPERATURE	251 1
XDS95	A6795B	LAMPHOLDER-FUEL SELECT LIGHT	240 1
XDS96	A6795B	LAMPHOLDER-FUEL SELECT LIGHT	240 1

EFFECTIVITY CODE

1. E-1111, E-1241 THRU E-1517; CE-748, CE-772 THRU CE-861; CJ-149 ONLY; D-10097, D-10120 THRU D-10247; EA-1 THRU EA-5

Beechcraft
BONANZA
WIRING DIAGRAM MANUAL

33-11-02

Configuration 1

**E-1518 THRU E-1945, E-1947 THRU E-2103, E-2105 THRU E-2110;
CE-862 THRU CE-1300, CE-1302 THRU CE-1306; CJ-150 THRU CJ-179;
D-10248 AND AFTER; EA-6 THRU EA-319, EA-321 THRU EA-388**

Beechcraft BONANZA WIRING DIAGRAM MANUAL

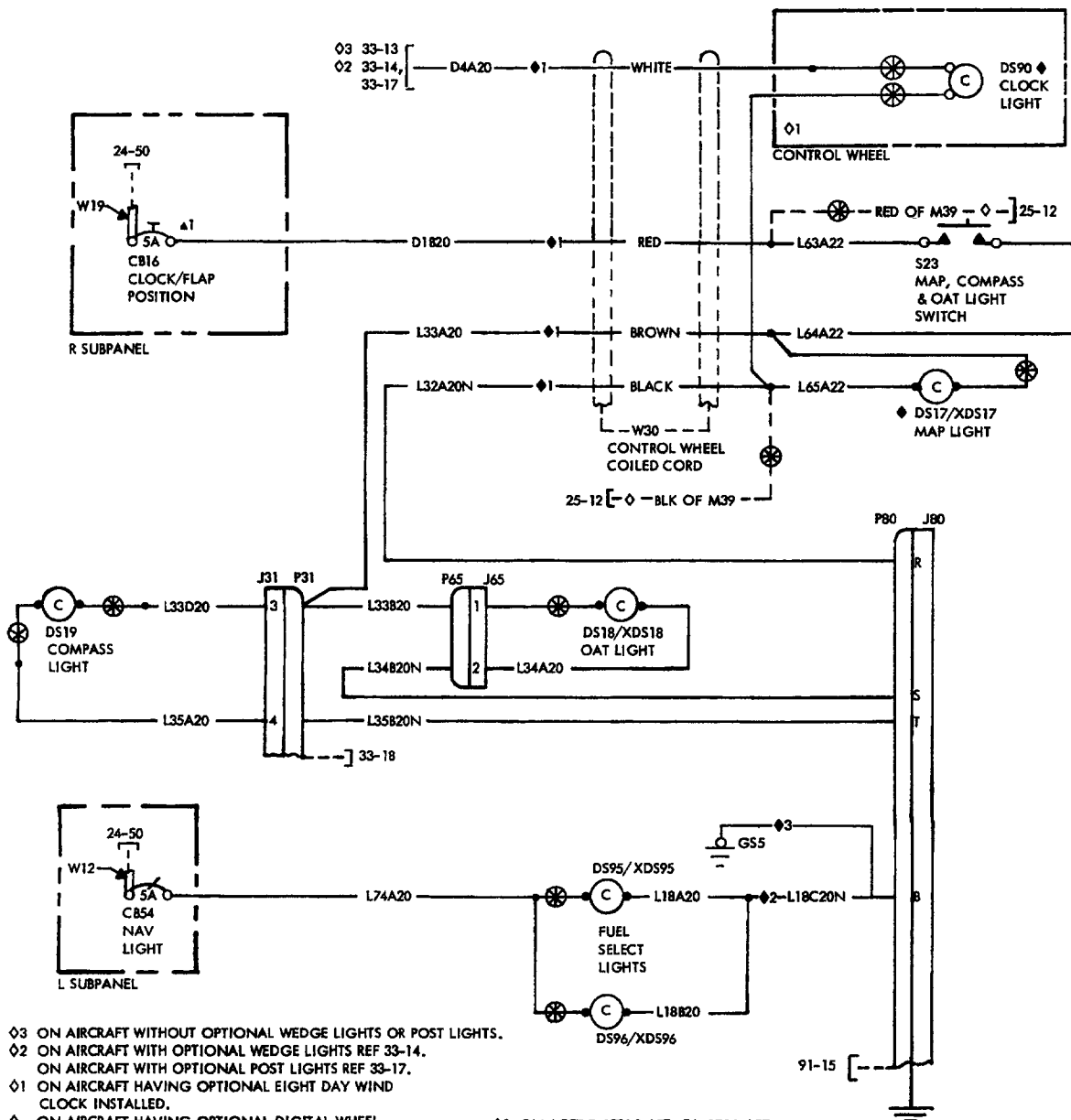

- ◆03 ON AIRCRAFT WITHOUT OPTIONAL WEDGE LIGHTS OR POST LIGHTS.
- ◆02 ON AIRCRAFT WITH OPTIONAL WEDGE LIGHTS REF 33-14.
ON AIRCRAFT WITH OPTIONAL POST LIGHTS REF 33-17.
- ◆01 ON AIRCRAFT HAVING OPTIONAL EIGHT DAY WIND
CLOCK INSTALLED.
- ◆ ON AIRCRAFT HAVING OPTIONAL DIGITAL WHEEL
CLOCK INSTALLED.
- ◆ OPTIONAL EQUIPMENT.
- ◆1 FOR MODE OF CONNECTION
TO COILED CORD, REFER TO
APPLICABLE AVIONICS DWG.
- ◆2 WIRE L18C MAY TERMINATE IN
PIN B OR ANDY OPEN PIN ON
CONN P/J80 THRU E-1790, EA-
177; CE-934; CJ-155 & D-10359.
- ◆3 ON ACFT E-1791 & AFT; EA-178 & AFT;
CE-935 & AFT; CJ-156 & AFT; D-10360
& AFT WIRE L18C GOES TO GND
STUD 5.

**LIGHTS-MAP, COMPASS, OAT AND FUEL SELECT
(Configuration 1)**

Beechcraft
BONANZA
WIRING DIAGRAM MANUAL

REFERENCE DESIGNATOR	PART NUMBER	DESCRIPTION	USABLE	
			INSTL ZONE	ON CODE
33-11-02 (Configuration 1)				
CB16	435-205-104	CIRCUIT BREAKER-CLOCK/FLAP POSITION	240	2
CB16	7277-2-5	CIRCUIT BREAKER-CLOCK/FLAP POSITION	240	3
CB54	35-380132-41	CIRCUIT BREAKER-NAVIGATION LIGHT	240	1
DS17	1495	LIGHT-MAP (OPTL)	240	1
DS18	MS25237-327	POST LIGHT-OUTSIDE AIR TEMPERATURE	251	1
DS19	327	LIGHT-COMPASS	240	1
DS90	267	LIGHT-CLOCK, CONTROL WHEEL (OPTL)	240	1
DS95	327	POST LIGHT-FUEL SELECT	251	1
DS96	327	POST LIGHT-FUEL SELECT	251	1
GS5	131270-3	GROUND STUD	140	1
J31A	1-480340-0	RECEPTACLE-GLARESHIELD	231	1
J31B	1-480345-0	PIN HOUSING	231	1
J31C	60618-1	PIN CONTACT	231	1
J65A	1-480319-0	RECEPTACLE-OUTSIDE AIR TEMPERATURE (OAT)	251	1
J65B	60617-1	SOCKET CONTACT	251	1
J80	204814-1	RECEPTACLE-GROUNDING BLOCK	231	1
P31A	1-480270-0	PLUG-GLARESHIELD	231	1
P31B	1-480283-0	SOCKET HOUSING	231	1
P31C	60617-1	SOCKET CONTACT	231	1
P65A	1-480318-0	PLUG-OUTSIDE AIR TEMPERATURE LIGHT	251	1
P65B	60618-1	PIN CONTACT	251	1
P80A	200838-3	PLUG-GROUNDING BLOCK	231	1
P80B	201224-1	STRAIN RELIEF	231	1
P80C	201328-1	SOCKET CONTACT	231	1
P80D	200333-1	SOCKET CONTACT	231	1
P80E	203618-1	JACKSCREW	231	1
S23	L18366-5	SWITCH-MAP, COMPASS, OAT LIGHT	240	1
W12	114931-1-6	BUS LIGHT	240	1
W19	114931-1-10	BUS BAR (OPTL)	240	1
W30	101-384082-3	COILED CORD	240	1
XDS17	96-364090-11	LAMPHOLDER-MAP LIGHT (OPTL)	240	1
XDS18	A6745B	LAMPHOLDER-OUTSIDE AIR TEMPERATURE	251	1
XDS95	A6795B	LAMPHOLDER-FUEL SELECT LIGHT	251	1
XDS96	A6795B	LAMPHOLDER-FUEL SELECT LIGHT	251	1

EFFECTIVITY CODE

1. E-1518 THRU E-1945, E-1947 THRU E-2103, E-2105 THRU E-2110; CE-862 THRU CE-1300, CE-1302 THRU CE-1306; CJ-150 THRU CJ-179; D-10248 AND AFTER; EA-6 THRU EA-319, EA-321 THRU EA-388
2. E-1518 THRU E-1765; CE-862 THRU CE-918, CE-920 THRU CE-928; CJ-150 THRU CJ-155; D-10248 THRU D-10347, D-10349 THRU D-10353; EA-6 THRU EA-158
3. E-1766 THRU E-1945, E-1947 THRU E-2103, E-2105 THRU E-2110; CE-919, CE-929 THRU CE-1300, CE-1302 THRU CE-1306; CJ-156 THRU CJ-179; D-10348, D-10354 AND AFTER; EA-159 THRU EA-319, EA-321 THRU EA-388

Beechcraft
BONANZA
WIRING DIAGRAM MANUAL

33-11-02

Configuration 2

CE-1301, CE-1307 AND AFTER; CJ-180 AND AFTER

Beechcraft BONANZA WIRING DIAGRAM MANUAL

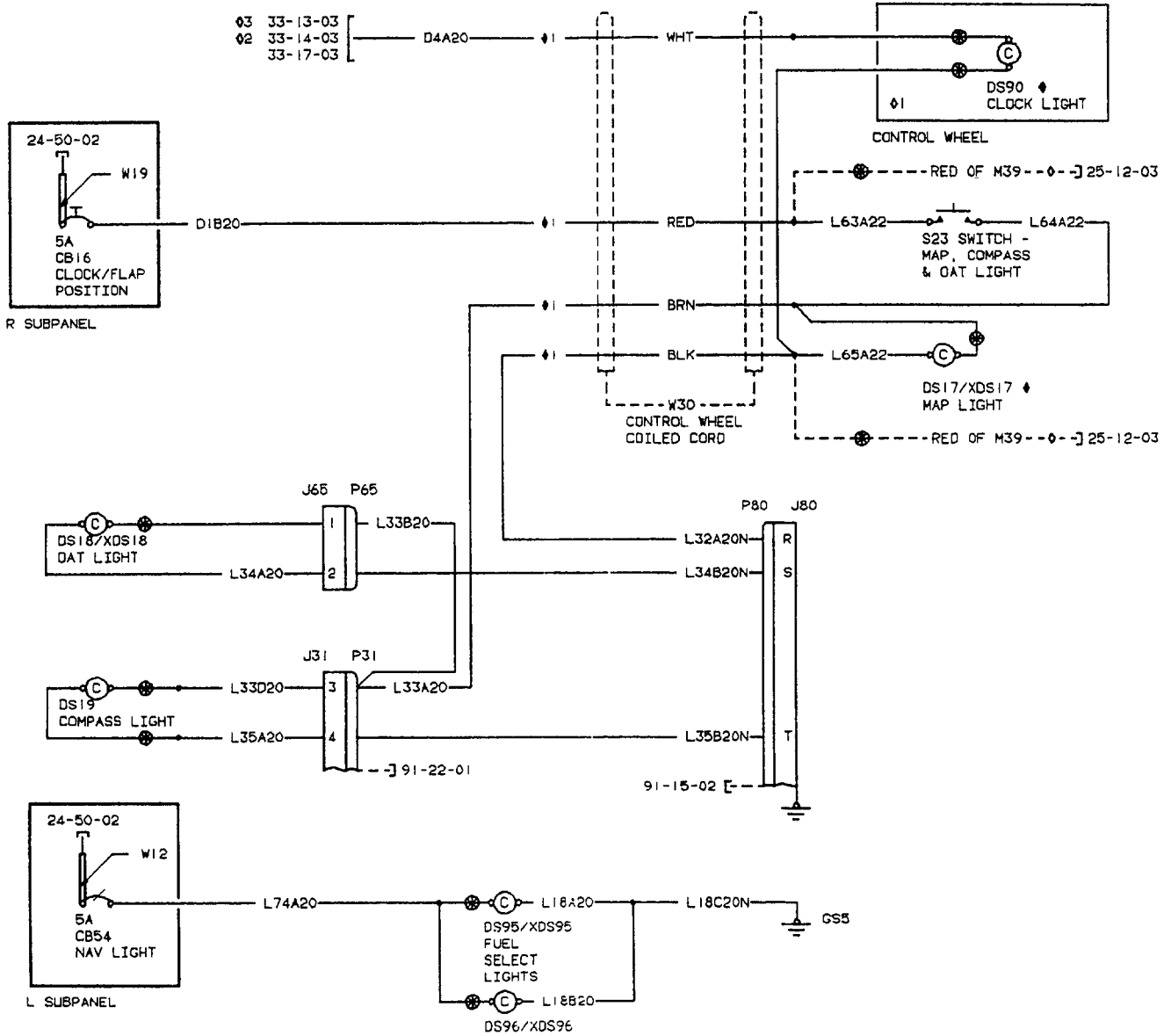

Ø3 ON AIRCRAFT WITHOUT OPTIONAL WEDGE LIGHTS OR POST LIGHTS.

Ø2 ON AIRCRAFT WITH OPTIONAL WEDGE LIGHTS REF 33-14-03.
ON AIRCRAFT WITH OPTIONAL POST LIGHTS REF 33-17-03.

Ø1 ON AIRCRAFT HAVING OPTIONAL EIGHT DAY
WIND CLOCK INSTALLED.

Ø ON AIRCRAFT HAVING OPTIONAL DIGITAL
WHEEL CLOCK INSTALLED

Ø1 FOR MODE OF CONNECTION TO COILED CORD,
REFER TO APPLICABLE AVIONICS DWG.

Ø OPTIONAL EQUIPMENT

LIGHTS-MAP, COMPASS, OAT AND FUEL SELECT (Configuration 2)

Beechcraft BONANZA WIRING DIAGRAM MANUAL

REFERENCE DESIGNATOR	PART NUMBER	DESCRIPTION	USABLE INSTL ON ZONE CODE
33-11-02 (Configuration 2)			
CB16	7277-2-5	CIRCUIT BREAKER-CLOCK/FLAP POSITION	240 1
CB54	35-380132-41	CIRCUIT BREAKER-NAVIGATION LIGHT	240 1
DS17	1495	LIGHT-MAP (OPTL)	240 1
DS18	MS25237-327	POST LIGHT-OUTSIDE AIR TEMPERATURE	251 1
DS19	327	LIGHT-COMPASS	240 1
DS90	267	LIGHT-CLOCK, CONTROL WHEEL (OPTL)	240 1
DS95	327	POST LIGHT-FUEL SELECT	251 1
DS96	327	POST LIGHT-FUEL SELECT	251 1
GS5	131270-3	GROUND STUD	140 1
J31A	1-480340-0	RECEPTACLE-GLARESHIELD	231 1
J31B	1-480345-0	PIN HOUSING	231 1
J31C	60618-1	PIN CONTACT	231 1
J65A	1-480319-0	RECEPTACLE-OUTSIDE AIR TEMPERATURE (OAT)	251 1
J65B	60617-1	SOCKET CONTACT	251 1
J80	204814-1	RECEPTACLE-GROUNDING BLOCK	231 1
P31A	1-480270-0	PLUG-GLARESHIELD	231 1
P31B	1-480283-0	SOCKET HOUSING	231 1
P31C	60617-1	SOCKET CONTACT	231 1
P65A	1-480318-0	PLUG-OUTSIDE AIR TEMPERATURE LIGHT	251 1
P65B	60618-1	PIN CONTACT	251 1
P80A	200838-3	PLUG-GROUNDING BLOCK	231 1
P80B	201224-1	STRAIN RELIEF	231 1
P80C	201328-1	SOCKET CONTACT	231 1
P80D	200333-1	SOCKET CONTACT	231 1
P80E	203618-1	JACKSCREW	231 1
S23	L18366-5	SWITCH-MAP, COMPASS, OAT LIGHT	240 1
W12	114931-1-6	BUS LIGHT	240 1
W19	114931-1-10	BUS BAR (OPTL)	240 1
W30	101-384082-3	COILED CORD	240 1
XDS17	96-364090-11	LAMPHOLDER-MAP LIGHT (OPTL)	240 1
XDS18	A6745B	LAMPHOLDER-OUTSIDE AIR TEMPERATURE	251 1
XDS95	A6795B	LAMPHOLDER-FUEL SELECT LIGHT	251 1
XDS96	A6795B	LAMPHOLDER-FUEL SELECT LIGHT	251 1

EFFECTIVITY CODE

1. CE-1301, CE-1307 AND AFTER; CJ-180 AND AFTER

Beechcraft
BONANZA
WIRING DIAGRAM MANUAL

33-12-01

**E-1111, E-1241 THRU E-1666; CE-748, CE-772 THRU CE-901; CJ-149
THRU CJ-155; D-10097, D-10120 THRU D-10342; EA-1 THRU EA-70**

Beechcraft BONANZA WIRING DIAGRAM MANUAL

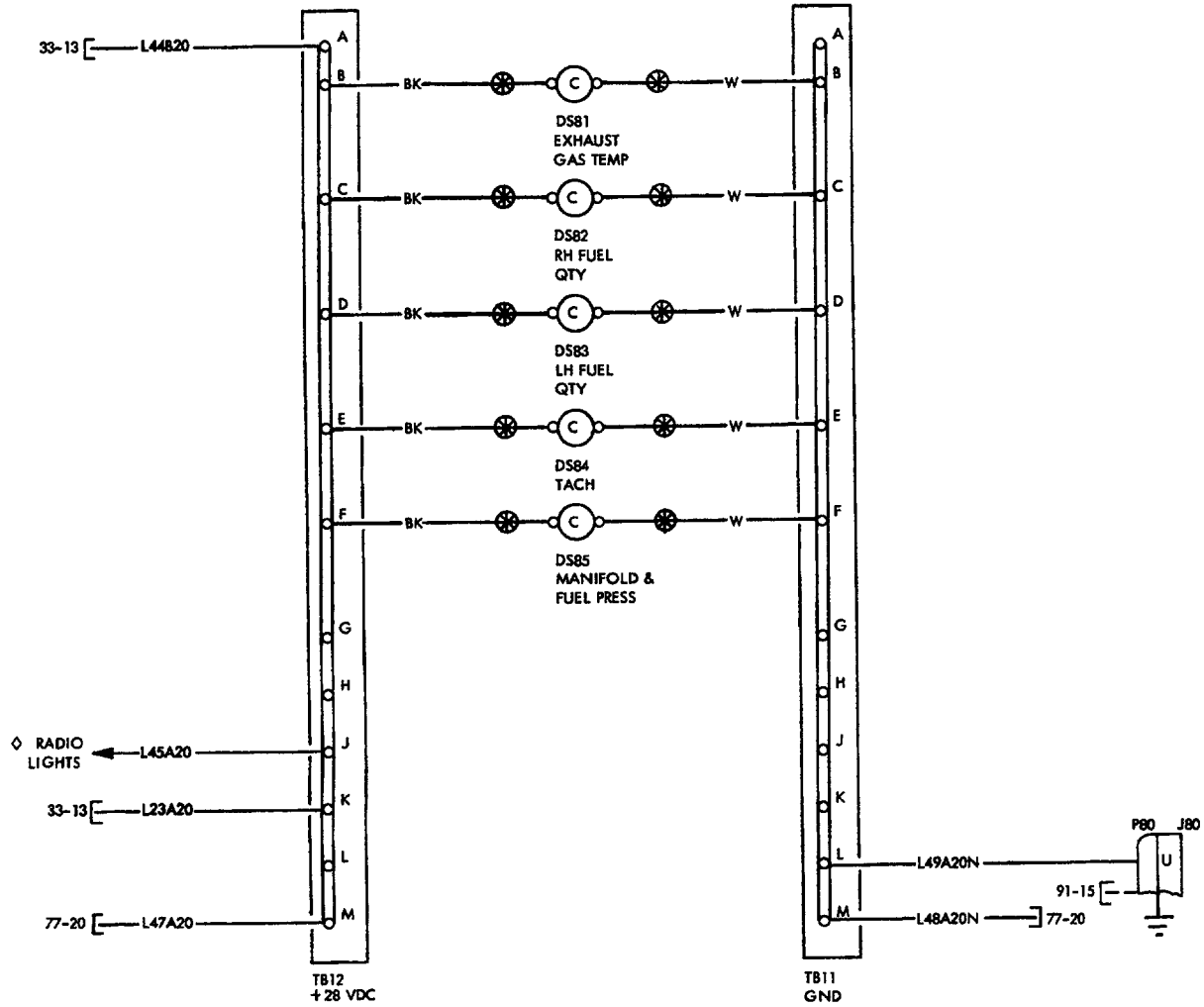

◇ SEE APPLICABLE AVIONICS DIAG FOR MODE OF CONNECTION.

LIGHTS-ENGINE INSTRUMENT WEDGE (OPTIONAL)

Beechcraft
BONANZA
WIRING DIAGRAM MANUAL

REFERENCE DESIGNATOR	PART NUMBER	DESCRIPTION	USABLE	
			INSTL ZONE	ON CODE
33-12-01				
DS81A	58-380022-11	LIGHT TRAY-EXHAUST GAS TEMPERATURE (OPTL)	240	1
DS81B	267	BULB (OPTL)	240	1
DS82A	58-380022-11	LIGHT TRAY-RIGHT FUEL QUANTITY (OPTL)	240	1
DS82B	267	BULB (OPTL)	240	1
DS83A	58-380022-11	LIGHT TRAY-LEFT FUEL QUANTITY (OPTL)	240	1
DS83B	267	BULB (OPTL)	240	1
DS84A	58-380022-11	LIGHT TRAY-TACHOMETER (OPTL)	240	1
DS84B	267	BULB (OPTL)	240	1
DS85A	58-380022-11	LIGHT TRAY-MANIFOLD AND FUEL PRESSURE (OPTL)	240	1
DS85B	267	BULB (OPTL)	240	1
J80	204814-1	RECEPTACLE-GROUNDING BLOCK	231	1
P80A	200838-3	PLUG-GROUNDING BLOCK	231	1
P80B	201224-1	STRAIN RELIEF	231	1
P80C	201328-1	SOCKET CONTACT	231	1
P80D	200333-1	SOCKET CONTACT	231	1
P80E	203618-1	JACKSCREW	231	1
TB11A	204228-2	TERMINAL BOARD (OPTL)	240	1
TB11B	203669-6	CONTACT PIN (OPTL)	240	1
TB12A	204228-2	TERMINAL BOARD (OPTL)	240	1
TB12B	203669-6	CONTACT PIN (OPTL)	240	1

EFFECTIVITY CODE

1. E-1111, E-1241 THRU E-1666; CE-748, CE-772 THRU CE-901; CJ-149 THRU CJ-155; D-10097, D-10120 THRU D-10342; EA-1 THRU EA-70

Beechcraft
BONANZA
WIRING DIAGRAM MANUAL

33-12-02

**E-1667 THRU E-1945, E-1947 THRU E-1999; CE-902 THRU CE-993;
D-10343 THRU D-10391; EA-71 THRU EA-296**

Beechcraft BONANZA WIRING DIAGRAM MANUAL

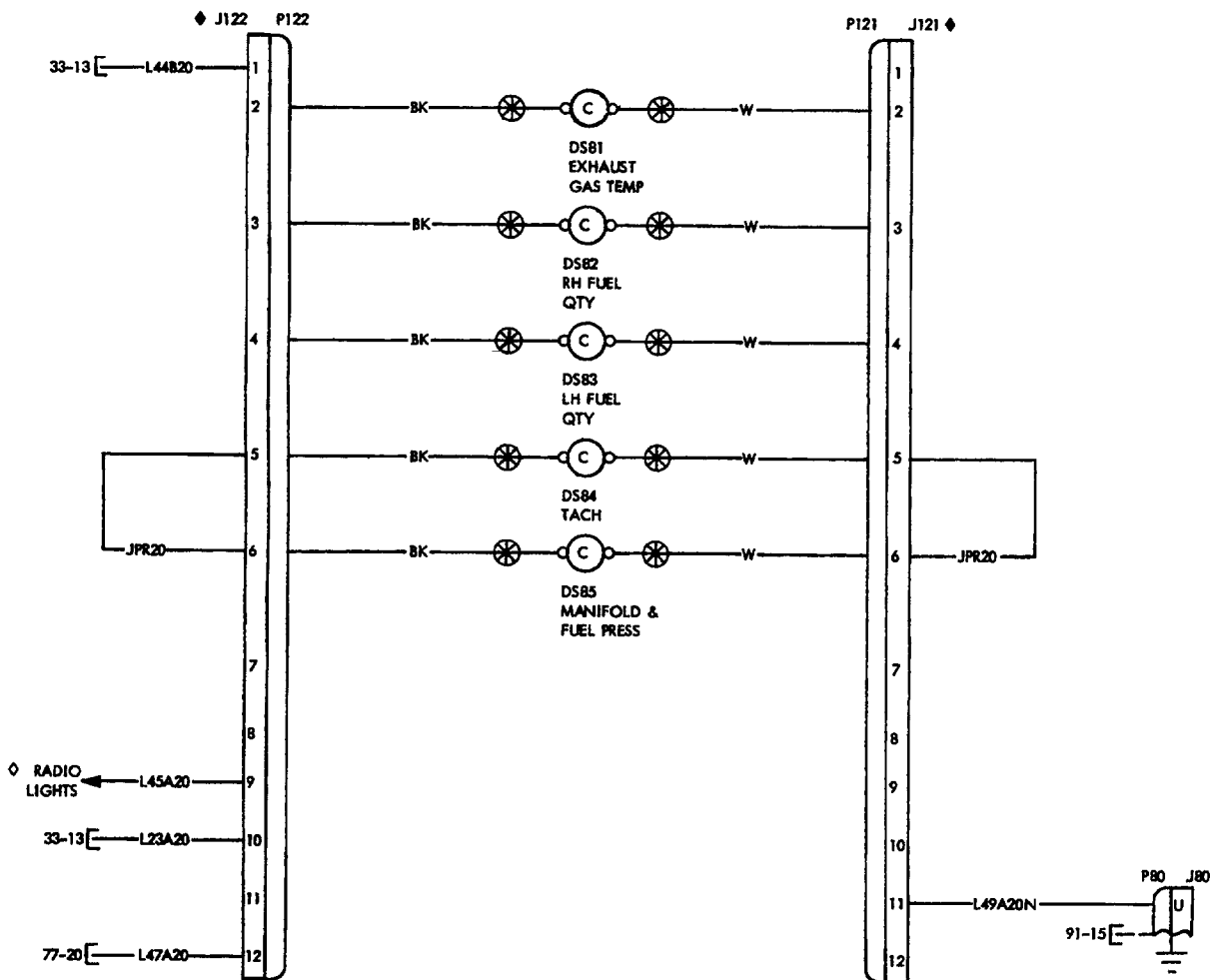

- ◇ SEE APPLICABLE AVIONICS DIAG FOR MODE OF CONNECTION.
- ◆ PIN HOUSING IS FILLED AND ALL PINS ARE BUSSED TOGETHER.

LIGHTS-ENGINE INSTRUMENT WEDGE (OPTIONAL)

Beechcraft
BONANZA
WIRING DIAGRAM MANUAL

REFERENCE DESIGNATOR	PART NUMBER	DESCRIPTION	USABLE	
			INSTL ZONE	ON CODE
33-12-02				
DS81A	58-380022-11	LIGHT TRAY-EXHAUST GAS TEMPERATURE (OPTL)	240	1
DS81B	267	BULB (OPTL)	240	1
DS82A	58-380022-11	LIGHT TRAY-RIGHT FUEL QUANTITY (OPTL)	240	1
DS82B	267	BULB (OPTL)	240	1
DS83A	58-380022-11	LIGHT TRAY-LEFT FUEL QUANTITY (OPTL)	240	1
DS83B	267	BULB (OPTL)	240	1
DS84A	58-380022-11	LIGHT TRAY-TACHOMETER (OPTL)	240	1
DS84B	267	BULB (OPTL)	240	1
DS85A	58-380022-11	LIGHT TRAY-MANIFOLD AND FUEL PRESSURE (OPTL)	240	1
DS85B	267	BULB (OPTL)	240	1
J121A	1-480288-0	RECEPTACLE-FIXED PANEL, COMMON	240	1
J121B	350444-5	COMMON TAB	240	1
J121C	60618-1	PIN CONTACT	240	1
J122A	1-480288-0	RECEPTACLE-FIXED PANEL, COMMON	240	1
J122B	350444-5	COMMON TAB	240	1
J122C	60618-1	PIN CONTACT	240	1
J80	204814-1	RECEPTACLE-GROUNDING BLOCK	231	1
P121A	1-480287-0	PLUG-FIXED PANEL, COMMON	240	1
P121B	60617-1	SOCKET CONTACT	240	1
P122A	1-480287-0	PLUG-FIXED PANEL, COMMON	240	1
P122B	60617-1	SOCKET CONTACT	240	1
P80A	200838-3	PLUG-GROUNDING BLOCK	231	1
P80B	201224-1	STRAIN RELIEF	231	1
P80C	201328-1	SOCKET CONTACT	231	1
P80D	200333-1	SOCKET CONTACT	231	1
P80E	203618-1	JACKSCREW	231	1

EFFECTIVITY CODE

1. E-1667 THRU E-1945, E-1947 THRU E-1999; CE-902 THRU CE-993; D-10343 THRU D-10391;
EA-71 THRU EA-296

Beechcraft
BONANZA
WIRING DIAGRAM MANUAL

33-12-03

**E-2000 THRU E-2103, E-2105 THRU E-2110; CE-994 AND AFTER;
CJ-156 AND AFTER; D-10392 AND AFTER; EA-297 THRU EA-319,
EA-321 THRU EA-388**

Beechcraft BONANZA WIRING DIAGRAM MANUAL

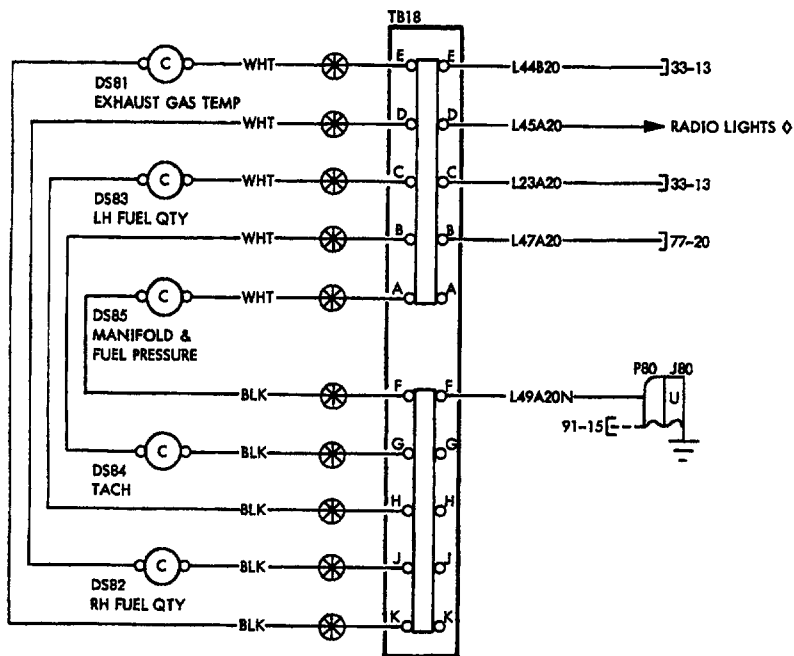

NOTE: DUE TO PANEL MODIFICATIONS, LIGHTS MAY BE MOVED TO DIFFERENT TERMINAL BLOCKS TO MAINTAIN PROPER GROUP DIMMING.

◇ SEE APPLICABLE AVIONICS DWG FOR MODE OF CONNECTION.

LIGHTS-ENGINE INSTRUMENT WEDGE (OPTIONAL)

Beechcraft
BONANZA
WIRING DIAGRAM MANUAL

REFERENCE DESIGNATOR	PART NUMBER	DESCRIPTION	USABLE INSTL ON ZONE CODE
33-12-03			
DS81A	58-380022-11	LIGHT TRAY-EXHAUST GAS TEMPERATURE (OPTL)	240 1
DS81B	267	BULB (OPTL)	240 1
DS82A	58-380022-11	LIGHT TRAY-RIGHT FUEL QUANTITY (OPTL)	240 1
DS82B	267	BULB (OPTL)	240 1
DS83A	58-380022-11	LIGHT TRAY-LEFT FUEL QUANTITY (OPTL)	240 1
DS83B	267	BULB (OPTL)	240 1
DS84A	58-380022-11	LIGHT TRAY-TACHOMETER (OPTL)	240 1
DS84B	267	BULB (OPTL)	240 1
DS85A	58-380022-11	LIGHT TRAY-MANIFOLD AND FUEL PRESSURE (OPTL)	240 1
DS85B	267	BULB (OPTL)	240 1
J80	204814-1	RECEPTACLE-GROUNDING BLOCK	231 1
P80A	200838-3	PLUG-GROUNDING BLOCK	231 1
P80B	201224-1	STRAIN RELIEF	231 1
P80C	201328-1	SOCKET CONTACT	231 1
P80D	200333-1	SOCKET CONTACT	231 1
P80E	203618-1	JACKSCREW	231 1
TB18	M81714/7-AB1	TERMINAL JUNCTION INSTALLATION LIGHTS (WEDGE)	240 1

EFFECTIVITY CODE

1. E-2000 THRU E-2103, E-2105 THRU E-2110; CE-994 AND AFTER; CJ-156 AND AFTER; D-10392 AND AFTER; EA-297 THRU EA-319, EA-321 THRU EA-388

Beechcraft
BONANZA
WIRING DIAGRAM MANUAL

33-13-01

**E-1111, E-1241 THRU E-1666; CE-748, CE-772 THRU CE-901; CJ-149
THRU CJ-155; D-10097, D-10120 THRU D-10342; EA-1 THRU EA-70**

Beechcraft BONANZA WIRING DIAGRAM MANUAL

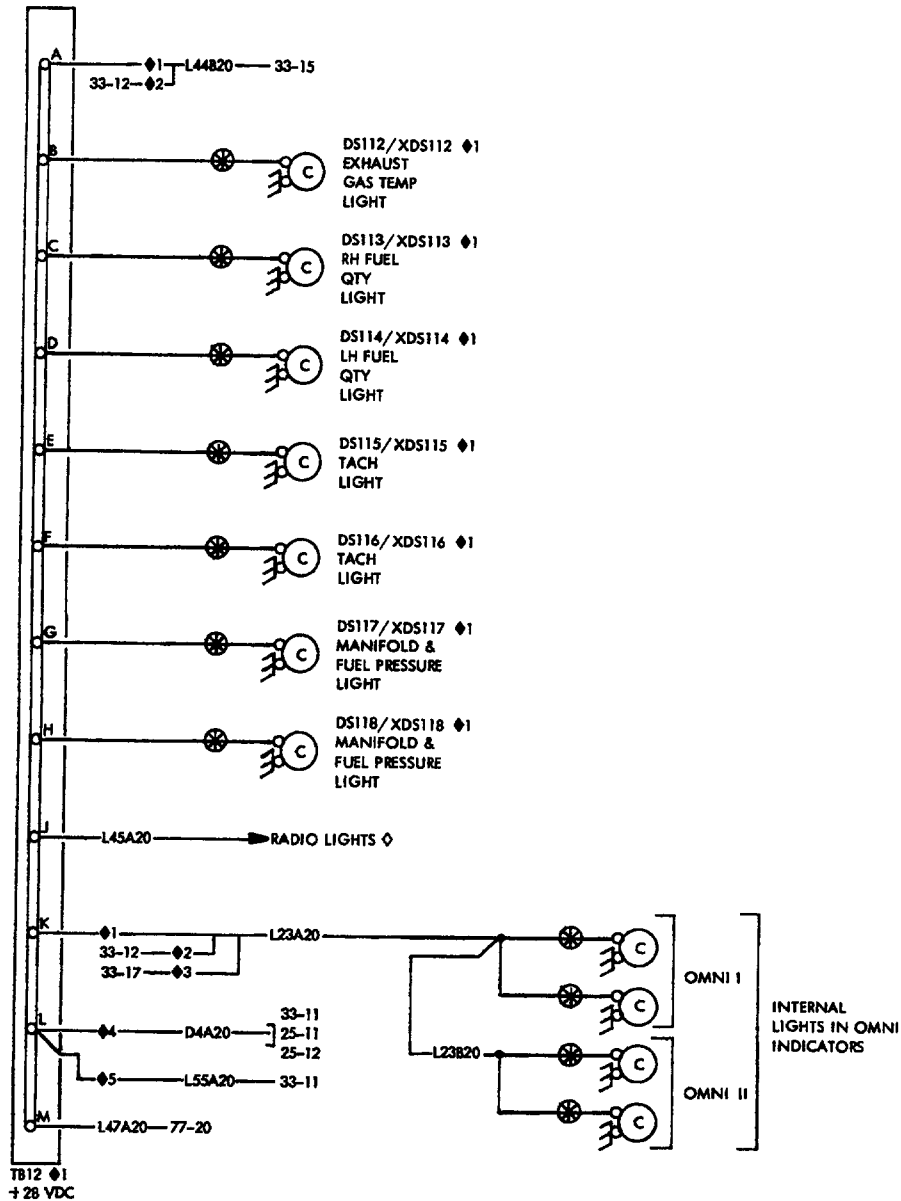

- ◆1 ON AIRCRAFT HAVING OPTIONAL POST LIGHTS INSTALLED, WIRES L23A & L44B ROUTED AS INDICATED AND EQUIPMENT USED.
- ◆2 ON AIRCRAFT HAVING OPTIONAL WEDGE LIGHTS INSTALLED, WIRES L23A & L44B CONNECTED AS SHOWN ON DIAGRAM 33-12.
- ◆3 WHEN OPTIONAL FLIGHT INSTRUMENT DIMMING IS USED, ROUTE WIRE L23A AS SHOWN ON DIAGRAM 33-17.
- ◆4 ON AIRCRAFT E-1518 & AFT, EA-6 & AFT, CE-862 & AFT, CJ-150 & AFT, D-10248 & AFT.
- ◆5 E-1111, E-1241 THRU E-1517; EA-1 THRU EA-5; CE-748, CE-772 THRU CE-861; CJ-149; D-10097, D-10120 THRU D-10247
- ◇ SEE APPLICABLE AVIONICS DIAG FOR MODE OF CONNECTION.

LIGHTS-RADIO AND ENGINE INSTRUMENT

Beechcraft
BONANZA
WIRING DIAGRAM MANUAL

REFERENCE DESIGNATOR	PART NUMBER	DESCRIPTION	USABLE INSTL ON ZONE CODE
33-13-01			
DS112	327	POST LIGHT-EXHAUST GAS TEMPERATURE	240 1
DS113	327	POST LIGHT-RIGHT FUEL QUANTITY	240 1
DS114	327	POST LIGHT-LEFT FUEL QUANTITY	240 1
DS115	327	POST LIGHT-TACHOMETER	240 1
DS116	327	POST LIGHT-TACHOMETER	240 1
DS117	327	POST LIGHT-MANIFOLD AND FUEL PRESSURE	240 1
DS118	327	POST LIGHT-MANIFOLD AND FUEL PRESSURE	240 1
TB12A	204228-2	TERMINAL BOARD (OPTL)	240 1
TB12B	203669-6	PIN CONTACT (OPTL)	240 1
XDS112	A8970B2	LAMPHOLDER-EXHAUST GAS TEMPERATURE	240 1
XDS113	A8970B2	LAMPHOLDER-RIGHT FUEL QUANTITY	240 1
XDS114	A8970B2	LAMPHOLDER-LEFT FUEL QUANTITY	240 1
XDS115	A8970B2	LAMPHOLDER-TACHOMETER	240 1
XDS116	A8970B2	LAMPHOLDER-TACHOMETER	240 1
XDS117	A8970B2	LAMPHOLDER-MANIFOLD AND FUEL PRESSURE	240 1
XDS118	A8970B2	LAMPHOLDER-MANIFOLD AND FUEL PRESSURE	240 1

EFFECTIVITY CODE

1. E-1111, E-1241 THRU E-1666; CE-748, CE-772 THRU CE-901; CJ-149 THRU CJ-155; D-10097, D-10120 THRU D-10342; EA-1 THRU EA-70

Beechcraft
BONANZA
WIRING DIAGRAM MANUAL

33-13-02

**E-1667 THRU E-1945, E-1947 THRU E-1999; CE-902 THRU CE-993;
D-10343 THRU D-10391; EA-71 THRU EA-296**

Beechcraft BONANZA WIRING DIAGRAM MANUAL

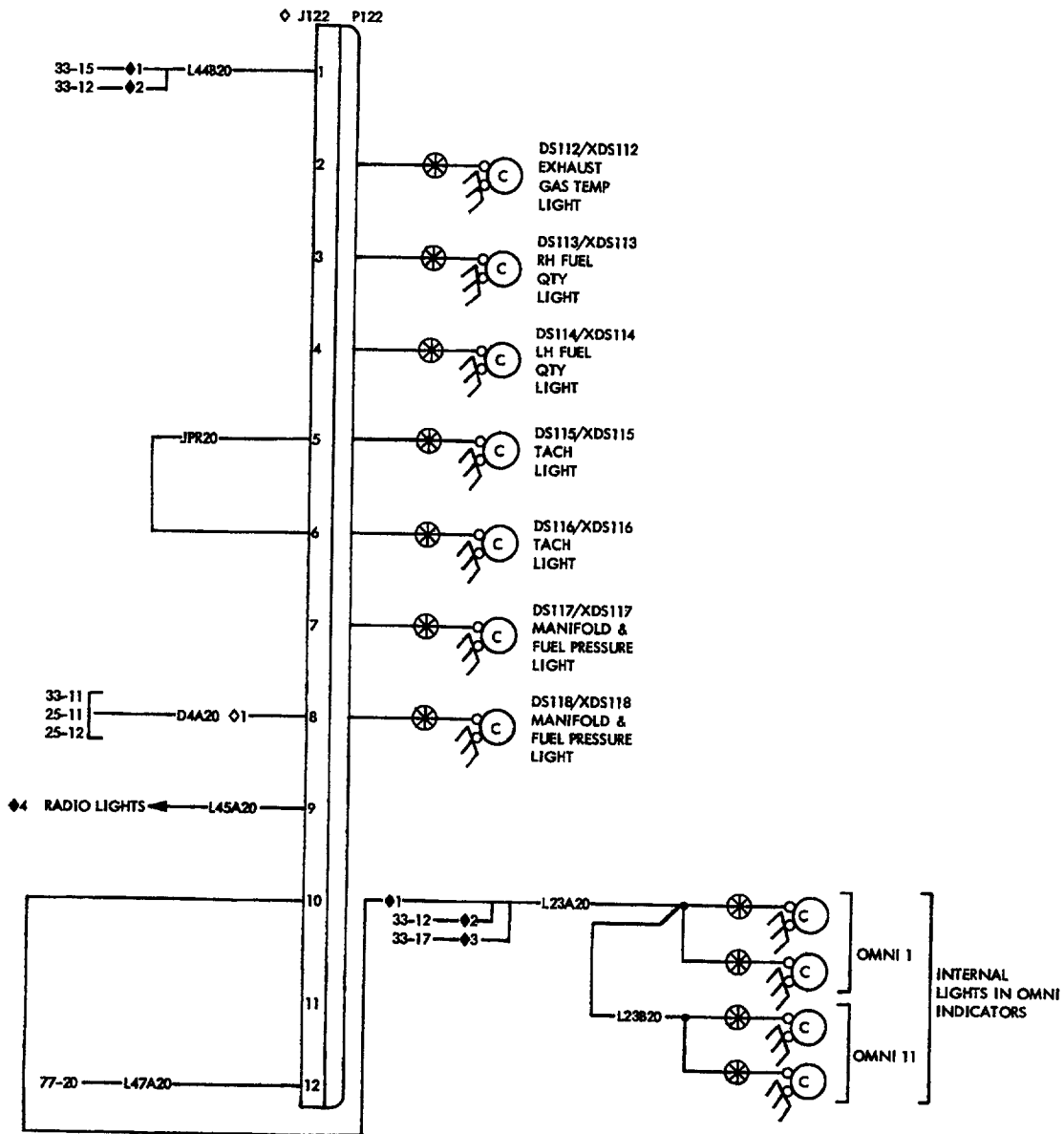

- ◇ PIN HOUSING IS FILLED & ALL PINS ARE BUSED TOGETHER.
- ◇1 ON ACFT WITHOUT OPTIONAL FLIGHT INSTR DIMMING WIRE AS SHOWN, ON ACFT WITH OPTIONAL FLIGHT INSTR DIMMING REF 33-17 FOR POST LIGHTS & 33-14 FOR WEDGE LIGHTS.
- ◇1 ON ACFT HAVING OPTIONAL POST LIGHTS INSTALLED, WIRES ROUTED AS INDICATED.
- ◇2 ON ACFT HAVING OPTIONAL WEDGE LIGHTS INSTALLED, WIRES CONNECTED AS SHOWN ON DIAGRAM 33-12.
- ◇3 WHEN OPTIONAL FLIGHT INSTRUMENT DIMMING IS USED, ROUTE WIRE L23A AS SHOWN ON DIAGRAM 33-17.
- ◇4 SEE APPLICABLE AVIONICS DIAG FOR MODE OF CONNECTION.

NOTE: POST LIGHTS MAY BE GROUNDED USING 20 AWG "GND" CODED OR BLACK JUMPER WIRES AS REQUIRED BETWEEN POST LIGHT MOUNTING STUDS. MAIN GROUND LEAD SHOULD TERMINATE IN GROUND PLUG.

LIGHTS-RADIO AND ENGINE INSTRUMENT

Beechcraft
BONANZA
WIRING DIAGRAM MANUAL

REFERENCE DESIGNATOR	PART NUMBER	DESCRIPTION	USABLE INSTL ON ZONE CODE
33-13-02			
DS112	327	POST LIGHT-EXHAUST GAS TEMPERATURE	240 1
DS113	327	POST LIGHT-RIGHT FUEL QUANTITY	240 1
DS114	327	POST LIGHT-LEFT FUEL QUANTITY	240 1
DS115	327	POST LIGHT-TACHOMETER	240 1
DS116	327	POST LIGHT-TACHOMETER	240 1
DS117	327	POST LIGHT-MANIFOLD AND FUEL PRESSURE	240 1
DS118	327	POST LIGHT-MANIFOLD AND FUEL PRESSURE	240 1
J122A	1-480288-0	RECEPTACLE-FIXED PANEL, COMMON	240 1
J122B	350444-5	COMMON TAB	240 1
J122C	60618-1	PIN CONTACT	240 1
P122A	1-480287-0	PLUG-FIXED PANEL, COMMON	240 1
P122B	60617-1	SOCKET CONTACT	240 1
XDS112	A8970B2	LAMPHOLDER-EXHAUST GAS TEMPERATURE	240 1
XDS113	A8970B2	LAMPHOLDER-RIGHT FUEL QUANTITY	240 1
XDS114	A8970B2	LAMPHOLDER-LEFT FUEL QUANTITY	240 1
XDS115	A8970B2	LAMPHOLDER-TACHOMETER	240 1
XDS116	A8970B2	LAMPHOLDER-TACHOMETER	240 1
XDS117	A8970B2	LAMPHOLDER-MANIFOLD AND FUEL PRESSURE	240 1
XDS118	A8970B2	LAMPHOLDER-MANIFOLD AND FUEL PRESSURE	240 1

EFFECTIVITY CODE

1. E-1667 THRU E-1945, E-1947 THRU E-1999; CE-902 THRU CE-993; D-10343 THRU D-10391;
EA-71 THRU EA-296

Beechcraft
BONANZA
WIRING DIAGRAM MANUAL

33-13-03

**E-2000 THRU E-2103, E-2105 THRU E-2110; CE-994 AND AFTER;
CJ-156 AND AFTER; D-10392 AND AFTER; EA-297 THRU EA-319,
EA-321 THRU EA-388**

Beechcraft BONANZA WIRING DIAGRAM MANUAL

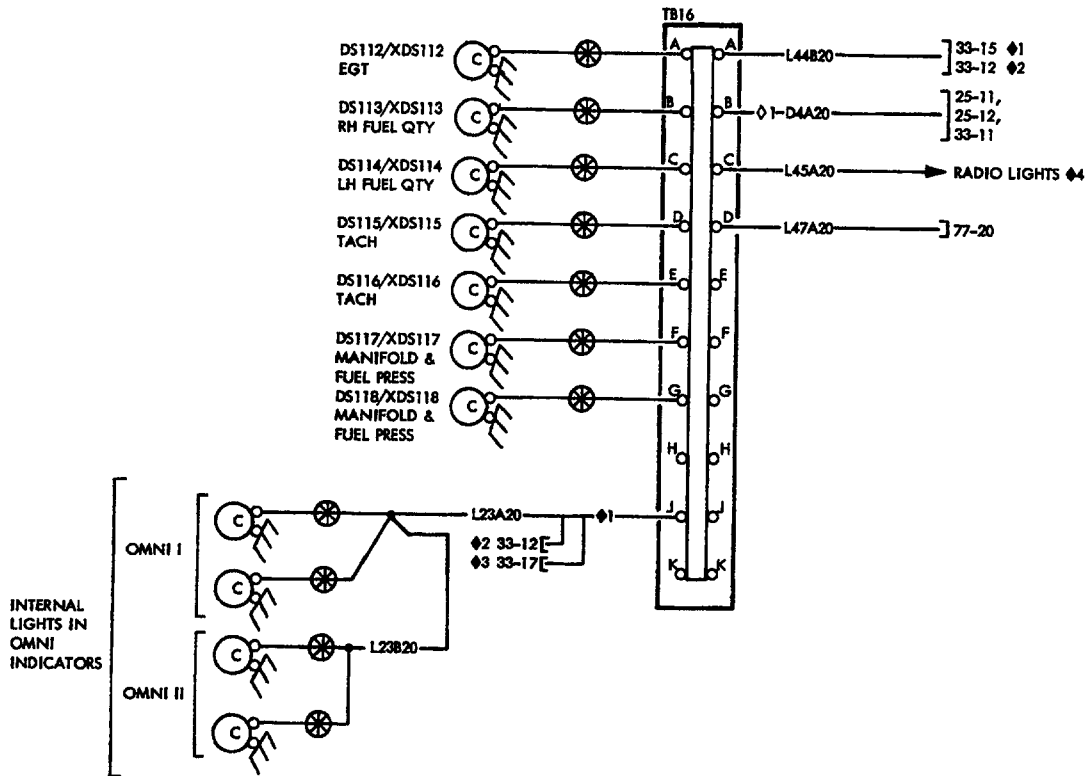

NOTE: DUE TO PANEL MODIFICATIONS, LIGHTS MAY BE MOVED TO DIFFERENT TERMINAL BLOCKS TO MAINTAIN PROPER GROUP DIMMING.

NOTE: POST LIGHTS MAY BE GROUNDED USING 20 AWG "GND" CODED OR BLACK JUMPER WIRES AS REQUIRED BETWEEN POST LIGHT MOUNTING STUDS. MAIN GROUND LEAD SHOULD TERMINATE IN GROUND PLUG.

- ◆1 ON ACFT HAVING OPTIONAL POST LIGHTS INSTALLED, WIRES ROUTED AS INDICATED.
- ◆2 ON ACFT HAVING OPTIONAL WEDGE LIGHTS INSTALLED, WIRES CONNECTED AS SHOWN ON DIAGRAM 33-12.
- ◆3 WHEN OPTIONAL FLIGHT INSTRUMENT DIMMING IS USED, ROUTE WIRE L23A AS SHOWN ON DIAGRAM 33-17.
- ◆4 SEE APPLICABLE AVIONICS DWG FOR MODE OF CONNECTION.

- ◆1 ON ACFT WITHOUT OPTIONAL FLIGHT INSTR DIMMING WIRE AS SHOWN. ON ACFT WITH OPTIONAL FLIGHT INSTR DIMMING REF 33-17 FOR POST LIGHTS & 33-14 FOR WEDGE LIGHTS.

LIGHTS-RADIO AND ENGINE INSTRUMENT POST

Deechcraft
BONANZA
WIRING DIAGRAM MANUAL

REFERENCE DESIGNATOR	PART NUMBER	DESCRIPTION	USABLE	
			INSTL	ON ZONE CODE
33-13-03				
DS112	327	POST LIGHT-EXHAUST GAS TEMPERATURE	240	1
DS113	327	POST LIGHT-RIGHT FUEL QUANTITY	240	1
DS114	327	POST LIGHT-LEFT FUEL QUANTITY	240	1
DS115	327	POST LIGHT-TACHOMETER	240	1
DS116	327	POST LIGHT-TACHOMETER	240	1
DS117	327	POST LIGHT-MANIFOLD AND FUEL PRESSURE	240	1
DS118	327	POST LIGHT-MANIFOLD AND FUEL PRESSURE	240	1
TB16	M81714/7-AA1	TERMINAL JUNCTION INSTALLATION LIGHTS (POST)	240	1
XDS112	A8970B2	LAMPHOLDER-EXHAUST GAS TEMPERATURE	240	1
XDS113	A8970B2	LAMPHOLDER-RIGHT FUEL QUANTITY	240	1
XDS114	A8970B2	LAMPHOLDER-LEFT FUEL QUANTITY	240	1
XDS115	A8970B2	LAMPHOLDER-TACHOMETER	240	1
XDS116	A8970B2	LAMPHOLDER-TACHOMETER	240	1
XDS117	A8970B2	LAMPHOLDER-MANIFOLD AND FUEL PRESSURE	240	1
XDS118	A8970B2	LAMPHOLDER-MANIFOLD AND FUEL PRESSURE	240	1

EFFECTIVITY CODE

1. E-2000 THRU E-2103, E-2105 THRU E-2110; CE-994 AND AFTER; CJ-156 AND AFTER; D-10392 AND AFTER; EA-297 THRU EA-319, EA-321 THRU EA-388

Beechcraft
BONANZA
WIRING DIAGRAM MANUAL

33-14-01

**E-1111, E-1241 THRU E-1666; CE-748, CE-772 THRU CE-901; CJ-149
THRU CJ-155; D-10097, D-10120 THRU D-10342; EA-1 THRU EA-70**

Beechcraft BONANZA WIRING DIAGRAM MANUAL

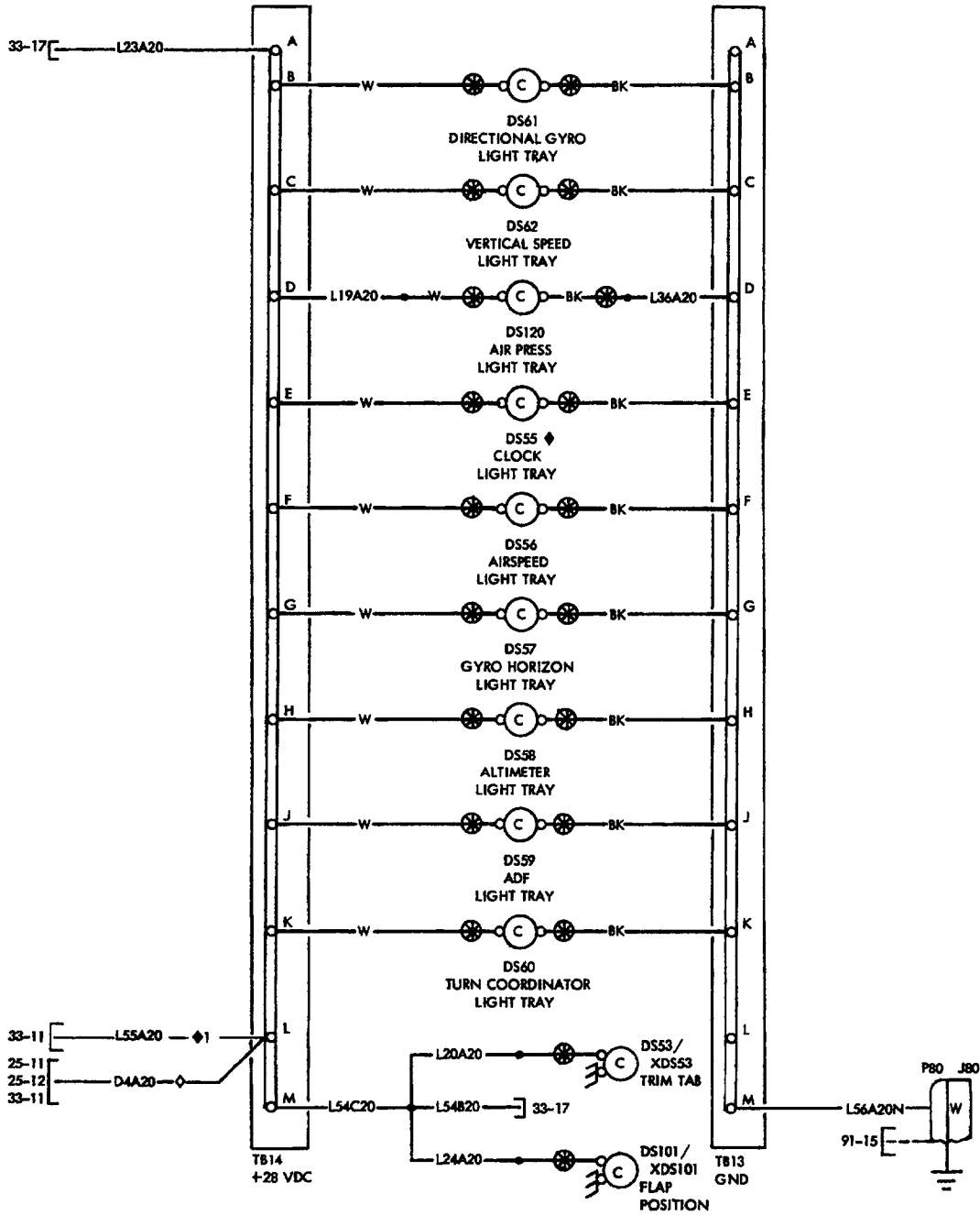

◆ ON AIRCRAFT E-1111, E-1241 THRU E-1517, EA-1 THRU EA-5, CE-748, CE-772 THRU CE-861, CJ-149, D-10097 & D-10120 THRU D-10247, LIGHT TRAY IS USED.

◆ ON ACFT E-1111, E-1241 THRU E-1517, EA-1 THRU EA-5, CE-748, CE-772 THRU CE-861; CJ-149; D-10097, D-10120 THRU D-10247.

◆ ON ACFT E-1518 & AFTER; EA-6 & AFTER; CE-862 & AFTER; CJ-150 & AFTER; D-10248 & AFTER.

LIGHTS-FLIGHT INSTRUMENT WEDGE (OPTIONAL)

Beechcraft
BONANZA
WIRING DIAGRAM MANUAL

REFERENCE DESIGNATOR	PART NUMBER	DESCRIPTION	USABLE	
			INSTL ZONE	ON CODE
33-14-01				
DS101	327	INDICATOR LIGHT-FLAP POSITION (OPTL)	240	1
DS120A	58-380022-11	LIGHT TRAY-AIR PRESSURE (OPTL)	240	1
DS120B	267	BULB (OPTL)	240	1
DS53A	1819	INDICATOR LIGHT-TRIM TAB (OPTL)	240	1
DS53B	D165-100-2	FILTER (OPTL)	240	1
DS55A	58-380022-11	LIGHT TRAY-CLOCK	240	2
DS55B	267	BULB	240	2
DS56A	58-380022-11	LIGHT TRAY-AIRSPD (OPTL)	240	1
DS56B	267	BULB (OPTL)	240	1
DS57A	58-380022-11	LIGHT TRAY-GYRO HORIZON (OPTL)	240	1
DS57B	267	BULB (OPTL)	240	1
DS58A	58-380022-11	LIGHT TRAY-ALTIMETER (OPTL)	240	1
DS58B	267	BULB (OPTL)	240	1
DS59A	58-380022-11	LIGHT TRAY-AUTOMATIC DIRECTION FINDER (OPTL)	240	1
DS59B	267	BULB (OPTL)	240	1
DS60A	58-380022-11	LIGHT TRAY-TURN COORDINATOR (OPTL)	240	1
DS60B	267	BULB (OPTL)	240	1
DS61A	58-380022-11	LIGHT TRAY-DIRECTIONAL GYRO (OPTL)	240	1
DS61B	267	BULB (OPTL)	240	1
DS62A	58-380022-11	LIGHT TRAY-VERTICAL SPEED (OPTL)	240	1
DS62B	267	BULB (OPTL)	240	1
J80	204814-1	RECEPTACLE-GROUNDING BLOCK	231	1
P80A	200838-3	PLUG-GROUNDING BLOCK	231	1
P80B	201224-1	STRAIN RELIEF	231	1
P80C	201328-1	SOCKET CONTACT	231	1
P80D	200333-1	SOCKET CONTACT	231	1
P80E	203618-1	JACKSCREW	231	1
TB13A	204228-2	TERMINAL BOARD (OPTL)	240	1
TB13B	203669-6	PIN CONTACT (OPTL)	240	1
TB14A	204228-2	TERMINAL BOARD (OPTL)	240	1
TB14B	203669-6	PIN CONTACT (OPTL)	240	1
XDS101	A8970B2	LAMPHOLDER-FLAP POSITION LIGHT (OPTL)	240	1
XDS53	PL-1	LAMPHOLDER-TRIM TAB LIGHT (OPTL)	240	1

EFFECTIVITY CODE

1. E-1111, E-1241 THRU E-1666; CE-748, CE-772 THRU CE-901; CJ-149 THRU CJ-155; D-10097, D-10120 THRU D-10342; EA-1 THRU EA-70

2. E-1111, E-1241 THRU E-1517; CE-748, CE-772 THRU CE-861; CJ-149 ONLY; D-10097, D-10120 THRU D-10247; EA-1 THRU EA-5

Beechcraft
BONANZA
WIRING DIAGRAM MANUAL

33-14-02

**E-1667 THRU E-1945, E-1947 THRU E-1999; CE-902 THRU CE-993;
D-10343 THRU D-10391; EA-71 THRU EA-296**

Beechcraft BONANZA WIRING DIAGRAM MANUAL

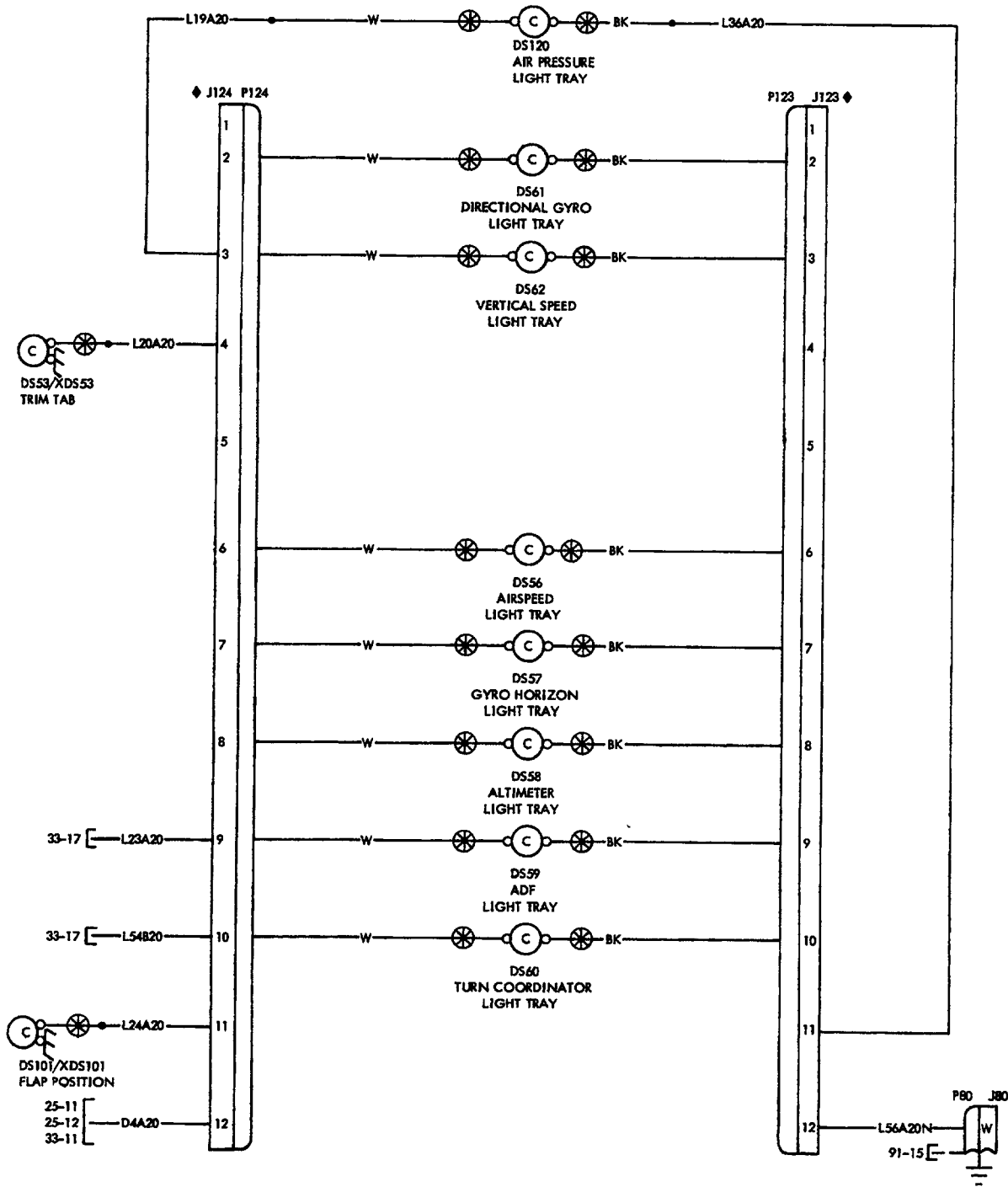

◆ PIN HOUSING IS FILLED AND ALL PINS ARE BUSED TOGETHER.

NOTE: POST LIGHTS MAY BE GROUNDED USING 20 AWG "GND" CODED OR BLACK JUMPER WIRES AS REQUIRED BETWEEN POST LIGHT MOUNTING STUDS. MAIN GROUND LEAD SHOULD TERMINATE IN GROUND PLUG.

LIGHTS-FLIGHT INSTRUMENT WEDGE (OPTIONAL)

Beechcraft BONANZA WIRING DIAGRAM MANUAL

REFERENCE DESIGNATOR	PART NUMBER	DESCRIPTION	USABLE INSTL ON ZONE CODE
33-14-02			
DS101	327	INDICATOR LIGHT-FLAP POSITION (OPTL)	240 1
DS120A	58-380022-11	LIGHT TRAY-AIR PRESSURE (OPTL)	240 1
DS120B	267	BULB (OPTL)	240 1
DS53A	1819	INDICATOR LIGHT-TRIM TAB (OPTL)	240 1
DS53B	D165-100-2	FILTER (OPTL)	240 1
DS56A	58-380022-11	LIGHT TRAY-AIRSPEED (OPTL)	240 1
DS56B	267	BULB (OPTL)	240 1
DS57A	58-380022-11	LIGHT TRAY-GYRO HORIZON (OPTL)	240 1
DS57B	267	BULB (OPTL)	240 1
DS58A	58-380022-11	LIGHT TRAY-ALTIMETER (OPTL)	240 1
DS58B	267	BULB (OPTL)	240 1
DS59A	58-380022-11	LIGHT TRAY-AUTOMATIC DIRECTION FINDER (OPTL)	240 1
DS59B	267	BULB (OPTL)	240 1
DS60A	58-380022-11	LIGHT TRAY-TURN COORDINATOR (OPTL)	240 1
DS60B	267	BULB (OPTL)	240 1
DS61A	58-380022-11	LIGHT TRAY-DIRECTIONAL GYRO (OPTL)	240 1
DS61B	267	BULB (OPTL)	240 1
DS62A	58-380022-11	LIGHT TRAY-VERTICAL SPEED (OPTL)	240 1
DS62B	267	BULB (OPTL)	240 1
J123A	1-480288-0	RECEPTACLE-FLOATING PANEL, COMMON	240 1
J123B	350444-5	COMMON TAB	240 1
J123C	60618-1	PIN CONTACT	240 1
J124A	1-480288-0	RECEPTACLE-FLOATING PANEL, COMMON	240 1
J124B	350444-5	COMMON TAB	240 1
J124C	60618-1	PIN CONTACT	240 1
J80	204814-1	RECEPTACLE-GROUNDING BLOCK	231 1
P123A	1-480287-0	PLUG-FLOATING PANEL, COMMON	240 1
P123B	60617-1	SOCKET CONTACT	240 1
P124A	1-480287-0	PLUG-FLOATING PANEL, COMMON	240 1
P124B	60617-1	SOCKET CONTACT	240 1
P80A	200838-3	PLUG-GROUNDING BLOCK	231 1
P80B	201224-1	STRAIN RELIEF	231 1
P80C	201328-1	SOCKET CONTACT	231 1
P80D	200333-1	SOCKET CONTACT	231 1
P80E	203618-1	JACKSCREW	231 1
XDS101	A8970B2	LAMPHOLDER-FLAP POSITION LIGHT (OPTL)	240 1
XDS53	PL-1	LAMPHOLDER-TRIM TAB LIGHT (OPTL)	240 1

EFFECTIVITY CODE

1. E-1667 THRU E-1945, E-1947 THRU E-1999; CE-902 THRU CE-993; D-10343 THRU D-10391;
EA-71 THRU EA-296

Beechcraft
BONANZA
WIRING DIAGRAM MANUAL

33-14-03

**E-2000 THRU E-2103, E-2105 THRU E-2110; CE-994 AND AFTER;
CJ-156 AND AFTER; D-10392 AND AFTER; EA-297 THRU EA-319,
EA-321 THRU EA-388**

Beechcraft BONANZA WIRING DIAGRAM MANUAL

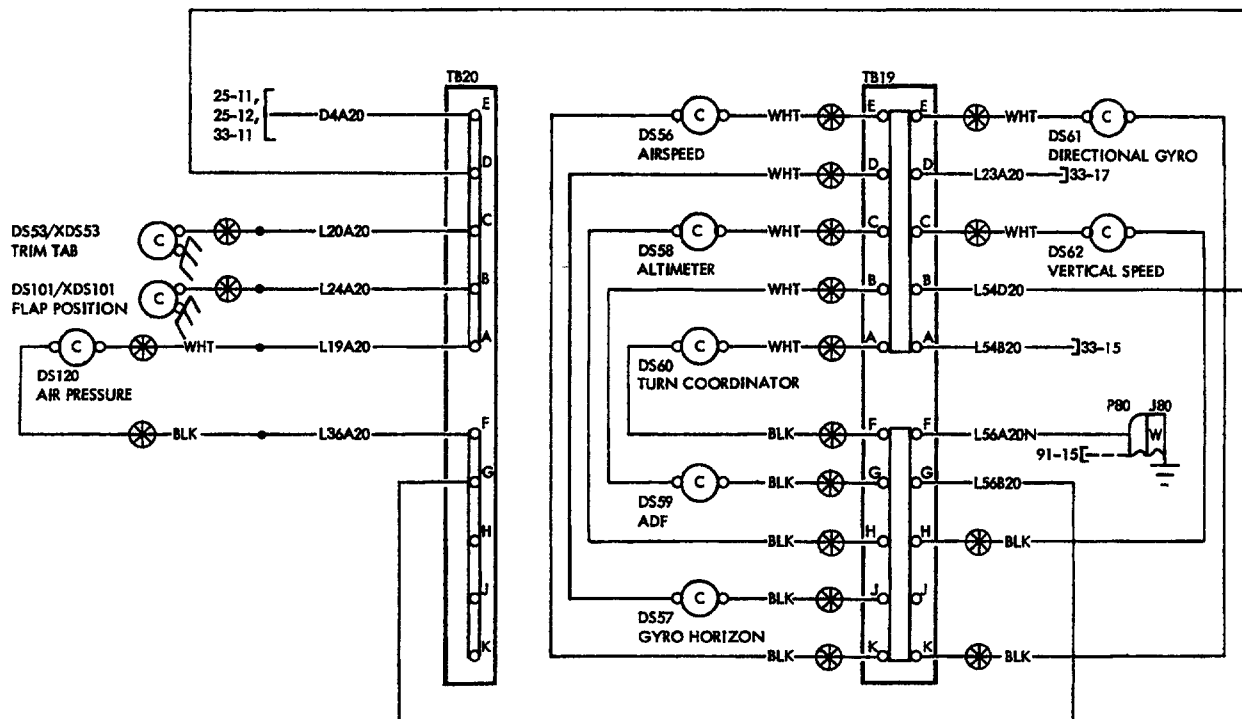

NOTE: DUE TO PANEL MODIFICATIONS, LIGHTS MAY BE MOVED TO DIFFERENT TERMINAL BLOCKS TO MAINTAIN PROPER GROUP DIMMING.

NOTE: POST LIGHTS MAY BE GROUNDED USING 20 AWG "GND" CODED OR BLACK JUMPER WIRES AS REQUIRED BETWEEN POST LIGHT MOUNTING STUDS. MAIN GROUND LEAD SHOULD TERMINATE IN GROUND PLUG.

LIGHTS-FLIGHT INSTRUMENT WEDGE (OPTIONAL)

Beechcraft
BONANZA
WIRING DIAGRAM MANUAL

REFERENCE DESIGNATOR	PART NUMBER	DESCRIPTION	USABLE	
			INSTL ZONE	ON CODE
33-14-03				
DS101	327	INDICATOR LIGHT-FLAP POSITION (OPTL)	240	1
DS120A	58-380022-11	LIGHT TRAY-AIR PRESSURE (OPTL)	240	1
DS120B	267	BULB (OPTL)	240	1
DS53A	1819	INDICATOR LIGHT-TRIM TAB (OPTL)	240	1
DS53B	D165-100-2	FILTER (OPTL)	240	1
DS56A	58-380022-11	LIGHT TRAY-AIRSPEED (OPTL)	240	1
DS56B	267	BULB (OPTL)	240	1
DS57A	58-380022-11	LIGHT TRAY-GYRO HORIZON (OPTL)	240	1
DS57B	267	BULB (OPTL)	240	1
DS58A	58-380022-11	LIGHT TRAY-ALTIMETER (OPTL)	240	1
DS58B	267	BULB (OPTL)	240	1
DS59A	58-380022-11	LIGHT TRAY-AUTOMATIC DIRECTION FINDER (OPTL)	240	1
DS59B	267	BULB (OPTL)	240	1
DS60A	58-380022-11	LIGHT TRAY-TURN COORDINATOR (OPTL)	240	1
DS60B	267	BULB (OPTL)	240	1
DS61A	58-380022-11	LIGHT TRAY-DIRECTIONAL GYRO (OPTL)	240	1
DS61B	267	BULB (OPTL)	240	1
DS62A	58-380022-11	LIGHT TRAY-VERTICAL SPEED (OPTL)	240	1
DS62B	267	BULB (OPTL)	240	1
J80	204814-1	RECEPTACLE-GROUNDING BLOCK	231	1
P80A	200838-3	PLUG-GROUNDING BLOCK	231	1
P80B	201224-1	STRAIN RELIEF	231	1
P80C	201328-1	SOCKET CONTACT	231	1
P80D	200333-1	SOCKET CONTACT	231	1
P80E	203618-1	JACKSCREW	231	1
TB19	M81714/7-AB1	TERMINAL JUNCTION INSTALLATION LIGHTS (WEDGE)	240	1
TB20	M81714/2-AB1	TERMINAL JUNCTION INSTALLATION LIGHTS (WEDGE)	240	1
XDS101	A8970B2	LAMPHOLDER-FLAP POSITION LIGHT (OPTL)	240	1
XDS53	PL-1	LAMPHOLDER-TRIM TAB LIGHT (OPTL)	240	1

EFFECTIVITY CODE

1. E-2000 THRU E-2103, E-2105 THRU E-2110; CE-994 AND AFTER; CJ-156 AND AFTER; D-10392 AND AFTER; EA-297 THRU EA-319, EA-321 THRU EA-388

Raytheon Aircraft

BEECH BONANZA WIRING DIAGRAM MANUAL

33-15-01

LIGHTS-DIMMING

**E-1111, E-1241 THRU E-1616; CE-748, CE-772 THRU CE-906; CJ-149 THRU CJ-160; D-10097, D-10120
THRU D-10321; EA-1 THRU EA-45**

Raytheon Aircraft

BEECH BONANZA WIRING DIAGRAM MANUAL

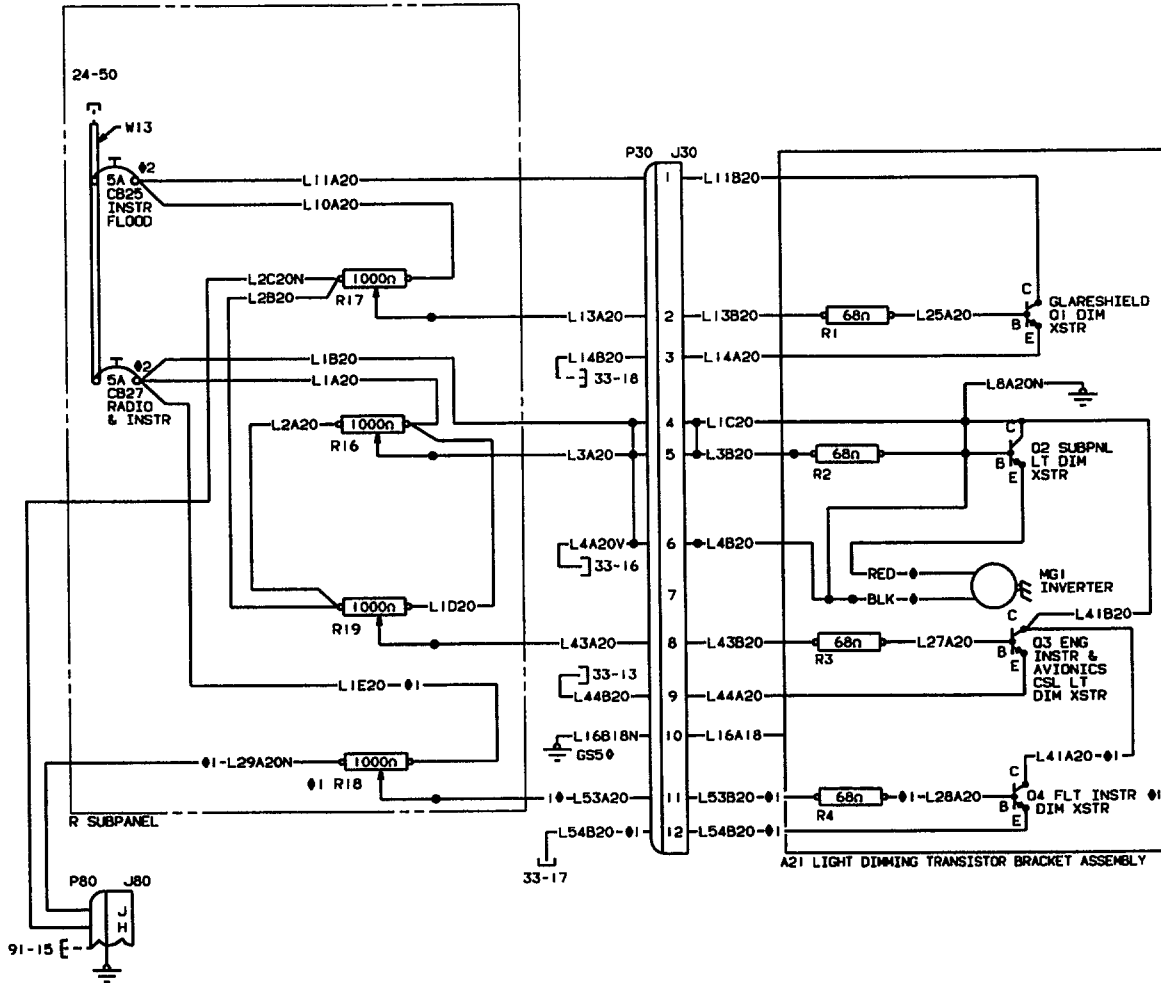

♦ CUT FURNISHED LEADS AS SHORT AS POSSIBLE AND TERMINATE SHIELDS AS CLOSE AS POSSIBLE TO INVERTER.

♦ 1 OPTIONAL EQUIPMENT.

♦ 2 ON A/C CJ-156 & AFTER SEE NOTE FOR CORRECT CIRCUIT BREAKER TYPE.

♦ ON AIRCRAFT E-1111, E-1241 THRU E-1551, EA-1 THRU EA-11, CE-748, CE-772 THRU CE-871, CJ-149 & CJ-150, D-10097 & D-10120 THRU D-10268, REF DES GS1 REPLACES GS5.

CE33F
982531AA

LIGHTS-DIMMING

E-1111, E-1241 THRU E-1616; CE-748, CE-772 THRU CE-906; CJ-149 THRU CJ-160;
D-10097, D-10120 THRU D-10321; EA-1 THRU EA-45

Raytheon Aircraft

BEECH BONANZA WIRING DIAGRAM MANUAL

REFERENCE DESIGNATOR	PART NUMBER	DESCRIPTION	INSTL ZONE	USABLE ON CODE
33-15-01				
A21	002-364042-35	BRACKET ASSEMBLY-ALTIMETER DIMMING TRANSISTOR	270	1
A21MG1	58-380101-1	BRACKET ASSEMBLY-INVERTER LIGHT DIMMING TRANSISTOR	270	1
A21Q1	2N3055	TRANSISTOR-GLARESHIELD DIMMING (SUPERSEDED BY 132404-42)	270	2
A21Q1	132404-42	TRANSISTOR-GLARESHIELD DIMMING (SUPERSEDES 2N3055)	270	2
A21Q1	2N3055H	TRANSISTOR-GLARESHIELD DIMMING (SUPERSEDED BY 132404-11)	270	3
A21Q1	132404-11	TRANSISTOR-GLARESHIELD DIMMING (SUPERSEDES 2N3055H)	270	3
A21Q2	2N3055	TRANSISTOR-SUBPANEL LIGHT DIMMING (SUPERSEDED BY 132404-42)	270	2
A21Q2	132404-42	TRANSISTOR-SUBPANEL LIGHT DIMMING (SUPERSEDES 2N3055)	270	2
A21Q2	2N3055H	TRANSISTOR-SUBPANEL LIGHT DIMMING (SUPERSEDED BY 132404-11)	270	3
A21Q2	132404-11	TRANSISTOR-SUBPANEL LIGHT DIMMING (SUPERSEDES 2N3055H)	270	3
A21Q3	2N3055	TRANSISTOR-ENGINE INSTRUMENTS AND AVIONICS LIGHT DIM (SUPERSEDED BY 132404-42)	270	2
A21Q3	132404-42	TRANSISTOR-ENGINE INSTRUMENTS AND AVIONICS LIGHT DIM (SUPERSEDES 2N3055)	270	2
A21Q3	2N3055H	TRANSISTOR-ENGINE INSTRUMENT AND AVIONICS LIGHT DIM (SUPERSEDED BY 132404-11)	270	3
A21Q3	132404-11	TRANSISTOR-ENGINE INSTRUMENT AND AVIONICS LIGHT DIM (SUPERSEDES 2N3055H)	270	3
A21Q4	2N3055	FLIGHT INSTRUMENT DIMMING TRANSISTOR (SUPERSEDED BY 132404-42)	270	2
A21Q4	132404-42	FLIGHT INSTRUMENT DIMMING TRANSISTOR (SUPERSEDES 2N3055)	270	2
A21Q4	2N3055H	FLIGHT INSTRUMENT DIMMING TRANSISTOR (SUPERSEDED BY 132404-11)	270	3
A21Q4	132404-11	FLIGHT INSTRUMENT DIMMING TRANSISTOR (SUPERSEDES 2N3055H)	270	3
A21R1	RCR42G680JS	BASE RESISTOR (SUPERSEDED BY 132371E68R0EFA)	270	1
A21R1	132371E68R0EFA	BASE RESISTOR (SUPERSEDES RCR42G680JS)	270	1
A21R2	RCR42G680JS	BASE RESISTOR (SUPERSEDED BY 132371E68R0EFA)	270	1
A21R2	132371E68R0EFA	BASE RESISTOR (SUPERSEDES RCR42G680JS)	270	1
A21R3	RCR42G680JS	BASE RESISTOR (SUPERSEDED BY 132371E68R0EFA)	270	1
A21R3	132371E68R0EFA	BASE RESISTOR (SUPERSEDES RCR42G680JS)	270	1
A21R4	RCR42G680JS	BASE RESISTOR (SUPERSEDED BY 132371E68R0EFA)	270	1
A21R4	132371E68R0EFA	BASE RESISTOR (SUPERSEDES RCR42G680JS)	270	1
CB25	435-205-104	CIRCUIT BREAKER-INSTRUMENT LIGHT	240	4
CB25	7277-2-5	CIRCUIT BREAKER-INSTRUMENT LIGHT	240	5
CB27	435-205-104	CIRCUIT BREAKER-RADIO AND INSTRUMENT LIGHT	240	4
CB27	7277-2-5	CIRCUIT BREAKER-RADIO AND INSTRUMENT LIGHT	240	5
GS1	131270-3	GROUND STUD-MAIN SPAR	270	1
GS5	131270-3	GROUND STUD	140	6
J30A	1-480288-0	RECEPTACLE-LIGHT DIMMING TRANSMITTER BRACKET	140	1

Raytheon Aircraft

BEECH BONANZA WIRING DIAGRAM MANUAL

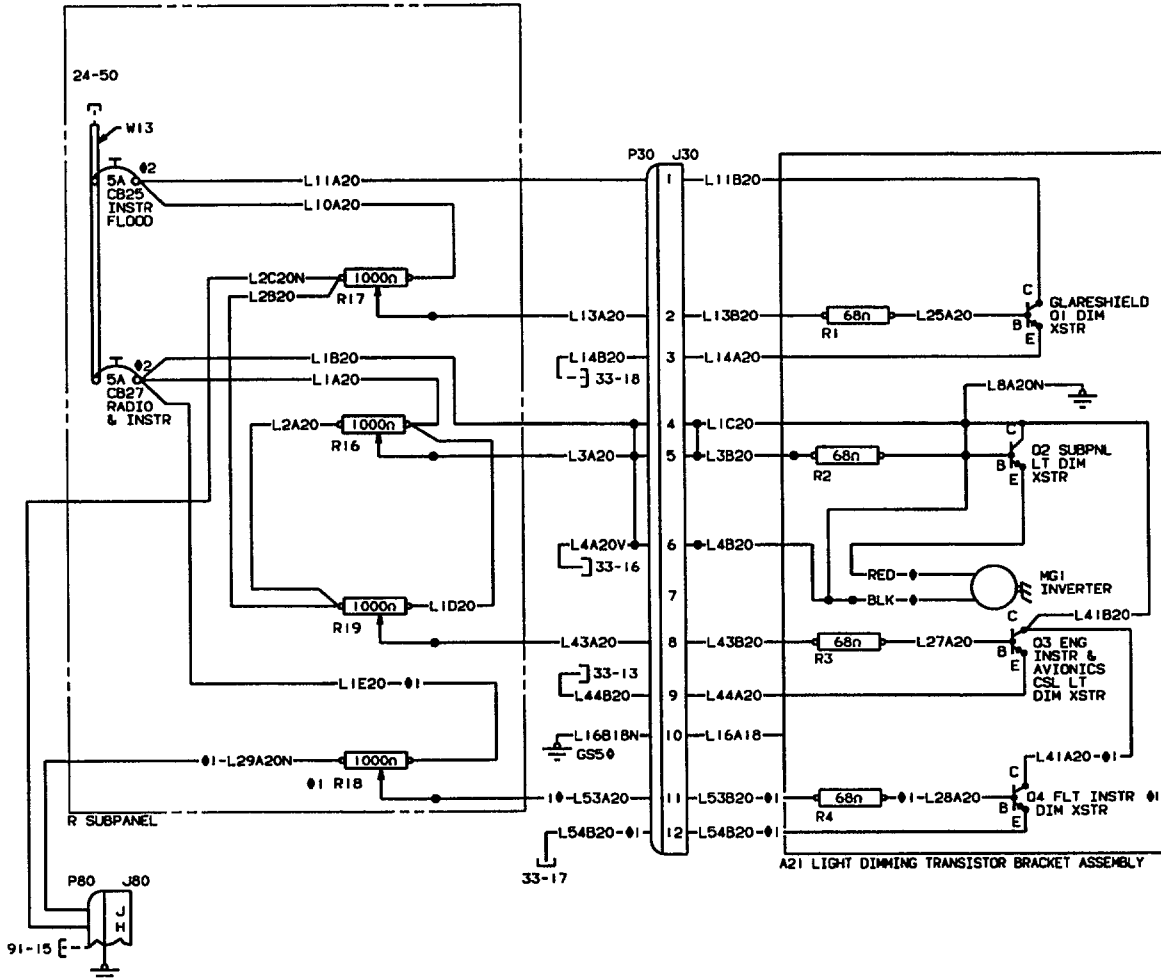

- ◆ CUT FURNISHED LEADS AS SHORT AS POSSIBLE AND TERMINATE SHIELDS AS CLOSE AS POSSIBLE TO INVERTER.
- ◆ 1 OPTIONAL EQUIPMENT.
- ◆ 2 ON A/C CJ-156 & AFTER SEE #1 NOTE FOR CORRECT CIRCUIT BREAKER TYPE.
- ◆ ON AIRCRAFT E-1111, E-1241 THRU E-1551, EA-1 THRU EA-11, CE-748, CE-772 THRU CE-871, CJ-149 & CJ-150, D-10097 & D-10120 THRU D-10268, REF DES GS1 REPLACES GS5.

CE33F
982531AA

LIGHTS-DIMMING

E-1111, E-1241 THRU E-1616; CE-748, CE-772 THRU CE-906; CJ-149 THRU CJ-160; D-10097, D-10120 THRU D-10321; EA-1 THRU EA-45

Raytheon Aircraft

BEECH BONANZA WIRING DIAGRAM MANUAL

REFERENCE DESIGNATOR	PART NUMBER	DESCRIPTION	INSTL ZONE	USABLE ON CODE
33-15-01				
J30B	60618-1	PIN CONTACT	140	1
J80	204814-1	RECEPTACLE-GROUNDING BLOCK	231	1
P30A	1-480287-0	PLUG-LIGHT DIMMING TRANSMITTER BRACKET	140	1
P30B	60617-1	SOCKET CONTACT	140	1
P80A	200838-3	PLUG-GROUNDING BLOCK	231	1
P80B	201224-1	STRAIN RELIEF	231	1
P80C	201328-1	SOCKET CONTACT	231	1
P80D	200333-1	SOCKET CONTACT	231	1
P80E	203618-1	JACKSCREW	231	1
R16	VW1KSPB	RHEOSTAT-LIGHT DIMMING	240	1
R17	VW1KSPB	RHEOSTAT-LIGHT DIMMING	240	1
R18	VW1KSPB	RHEOSTAT-LIGHT DIMMING (OPTL)	240	1
R19	VW1KSPB	RHEOSTAT-LIGHT DIMMING	240	1
W13	114931-1-12	BUS-MAIN	240	1

CODES OF EFFECTIVITY

1. E-1111, E-1241 THRU E-1616; CE-748, CE-772 THRU CE-906; CJ-149 THRU CJ-160; D-10097, D-10120 THRU D-10321; EA-1 THRU EA-45
2. E-1111, E-1241 THRU E-1399; CE-748, CE-772 THRU CE-826; D-10097, D-10120 THRU D-10193; EA-1 AND EA-2
3. E-1400 THRU E-1616; CE-827 THRU CE-906; CJ-149 THRU CJ-160; D-10194 THRU D-10321; EA-3 THRU EA-45
4. E-1111, E-1241 THRU E-1616; CE-748, CE-772 THRU CE-906; CJ-149 THRU CJ-155; D-10097, D-10120 THRU D-10321; EA-1 THRU EA-45
5. CJ-156 THRU CJ-160
6. E-1552 THRU E-1616; CE-872 THRU CE-906; CJ-151 THRU CJ-160; D-10269 THRU D-10321; EA-1 THRU EA-45

Raytheon Aircraft

BEECH BONANZA WIRING DIAGRAM MANUAL

33-15-02

LIGHTS-DIMMING

E-1617 THRU E-1945, E-1947 THRU E-2103, E-2105 THRU E-2110; CE-907 AND AFTER; CJ-161 AND AFTER; D-10322 AND AFTER; EA-46 THRU EA-319, EA-321 THRU EA-388

Raytheon Aircraft

BEECH BONANZA WIRING DIAGRAM MANUAL

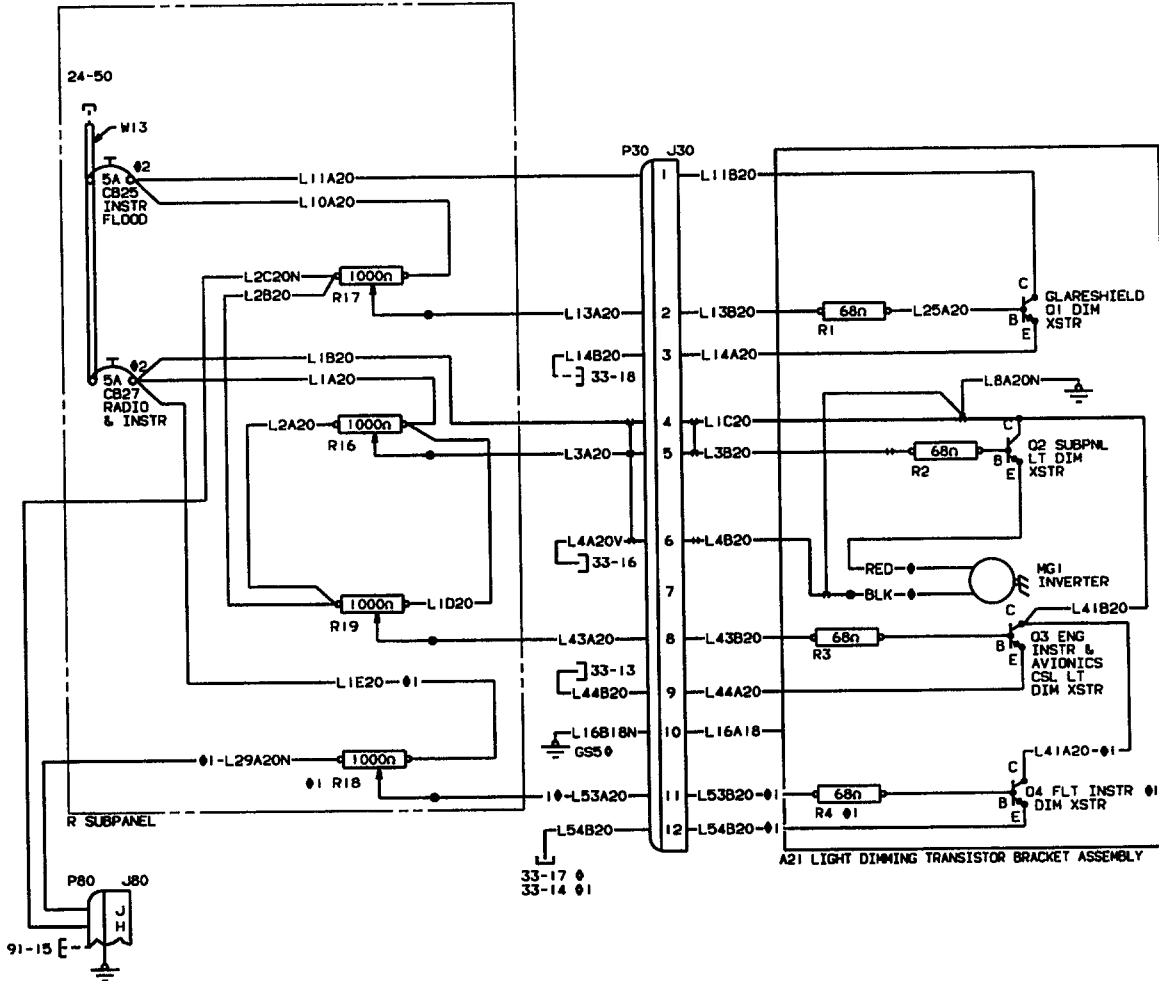

- ◆ CUT FURNISHED LEADS AS SHORT AS POSSIBLE AND TERMINATE SHIELDS AS CLOSE AS POSSIBLE TO INVERTER.
- ◆ I OPTIONAL EQUIPMENT.
- ◆ OPTIONAL POST LIGHTS.
- ◆ I OPTIONAL WEDGE LIGHTS.

CE33F
982532AA

LIGHTS-DIMMING

E-1617 THRU E-1945, E-1947 THRU E-2103, E-2105 THRU E-2110; CE-907 AND AFTER; CJ-161 AND AFTER; D-10322 AND AFTER; EA-46 THRU EA-319, EA-321 THRU EA-388

Raytheon Aircraft

BEECH BONANZA WIRING DIAGRAM MANUAL

REFERENCE DESIGNATOR	PART NUMBER	DESCRIPTION	INSTL ZONE	USABLE ON CODE
33-15-02				
A21	002-364042-35	BRACKET ASSEMBLY-ALTIMETER DIMMING TRANSISTOR	270	1
A21MG1	58-380101-1	BRACKET ASSEMBLY-INVERTER LIGHT DIMMING TRANSISTOR	270	1
A21Q1	2N3055H	TRANSISTOR-GLARESHIELD DIMMING (SUPERSEDED BY 132404-11)	270	1
A21Q1	132404-11	TRANSISTOR-GLARESHIELD DIMMING (SUPERSEDES 2N3055H)	270	1
A21Q2	2N3055H	TRANSISTOR-SUBPANEL LIGHT DIMMING (SUPERSEDED BY 132404-11)	270	1
A21Q2	132404-11	TRANSISTOR-SUBPANEL LIGHT DIMMING (SUPERSEDES 2N3055H)	270	1
A21Q3	2N3055H	TRANSISTOR-ENGINE INSTRUMENT AND AVIONICS LIGHT DIM (SUPERSEDED BY 132404-11)	270	1
A21Q3	132404-11	TRANSISTOR-ENGINE INSTRUMENT AND AVIONICS LIGHT DIM (SUPERSEDES 2N3055H)	270	1
A21Q4	2N3055H	TRANSISTOR-FLIGHT INSTRUMENT LIGHT DIMMING (SUPERSEDED BY 132404-11)	270	1
A21Q4	132404-11	TRANSISTOR-FLIGHT INSTRUMENT LIGHT DIMMING (SUPERSEDES 2N3055H)	270	1
A21R1	RCR42G680JS	BASE RESISTOR (SUPERSEDED BY 132371E68R0EFA)	270	1
A21R1	132371E68R0EFA	BASE RESISTOR (SUPERSEDES RCR42G680JS)	270	1
A21R2	RCR42G680JS	BASE RESISTOR (SUPERSEDED BY 132371E68R0EFA)	270	1
A21R2	132371E68R0EFA	BASE RESISTOR (SUPERSEDES RCR42G680JS)	270	1
A21R3	RCR42G680JS	BASE RESISTOR (SUPERSEDED BY 132371E68R0EFA)	270	1
A21R3	132371E68R0EFA	BASE RESISTOR (SUPERSEDES RCR42G680JS)	270	1
A21R4	RCR42G680JS	BASE RESISTOR (SUPERSEDED BY 132371E68R0EFA)	270	1
A21R4	132371E68R0EFA	BASE RESISTOR (SUPERSEDES RCR42G680JS)	270	1
CB25	435-205-104	CIRCUIT BREAKER-INSTRUMENT LIGHT	240	2
CB25	7277-2-5	CIRCUIT BREAKER-INSTRUMENT LIGHT	240	3
CB27	435-205-104	CIRCUIT BREAKER-RADIO AND INSTRUMENT LIGHT	240	2
CB27	7277-2-5	CIRCUIT BREAKER-RADIO AND INSTRUMENT LIGHT	240	3
GS5	131270-3	GROUND STUD	140	1
J30A	1-480288-0	RECEPTACLE-LIGHT DIMMING TRANSMITTER BRACKET	140	1
J30B	60618-1	PIN CONTACT	140	1
J80	204814-1	RECEPTACLE-GROUNDING BLOCK	231	1
P30A	1-480287-0	PLUG-LIGHT DIMMING TRANSMITTER BRACKET	140	1
P30B	60617-1	SOCKET CONTACT	140	1
P80A	200838-3	PLUG-GROUNDING BLOCK	231	1
P80B	201224-1	STRAIN RELIEF	231	1
P80C	201328-1	SOCKET CONTACT	231	1
P80D	200333-1	SOCKET CONTACT	231	1
P80E	203618-1	JACKSCREW	231	1
R16	VW1KSPB	RHEOSTAT-LIGHT DIMMING	240	1
R17	VW1KSPB	RHEOSTAT-LIGHT DIMMING	240	1
R18	VW1KSPB	RHEOSTAT-LIGHT DIMMING (OPTL)	240	1
R19	VW1KSPB	RHEOSTAT-LIGHT DIMMING	240	1

Raytheon Aircraft

BEECH BONANZA WIRING DIAGRAM MANUAL

REFERENCE DESIGNATOR	PART NUMBER	DESCRIPTION	INSTL ZONE	USABLE ON CODE
		33-15-02		
W13	114931-12	BUS-MAIN	240	1

CODES OF EFFECTIVITY

1. E-1617 THRU E-1945, E-1947 THRU E-2103, E-2105 THRU E-2110; CE-907 AND AFTER; CJ-161 AND AFTER; D-10322 AND AFTER; EA-46 THRU EA-319, EA-321 THRU EA-388
2. E-1617 THRU E-1765; CE-907 THRU CE-918, CE-920 THRU CE-928; D-10322 THRU D-10347, D-10349 THRU D-10353; EA-46 THRU EA-158
3. E-1766 THRU E-1945, E-1947 THRU E-2103, E-2105 THRU E-2110; CE-919, CE-929 AND AFTER; CJ-161 AND AFTER; D-10348, D-10354 AND AFTER; EA-159 THRU EA-319, EA-321 THRU EA-388

Beechcraft
BONANZA
WIRING DIAGRAM MANUAL

33-16-01

**E-1111, E-1241 THRU E-1945, E-1947 THRU E-2103, E-2105 THRU
E-2110; CE-748, CE-772 AND AFTER; CJ-149 AND AFTER; D-10097,
D-10120 AND AFTER; EA-1 THRU EA-319, EA-321 THRU EA-388**

Beechcraft BONANZA WIRING DIAGRAM MANUAL

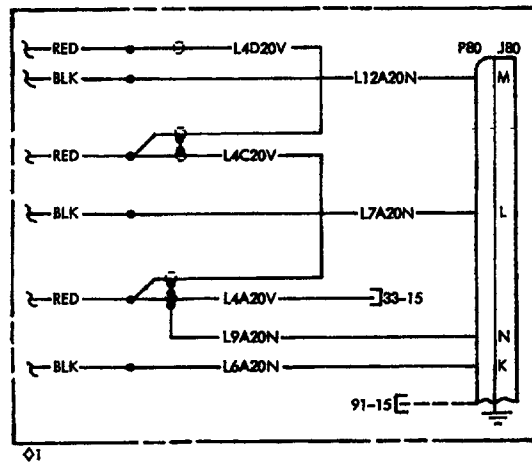
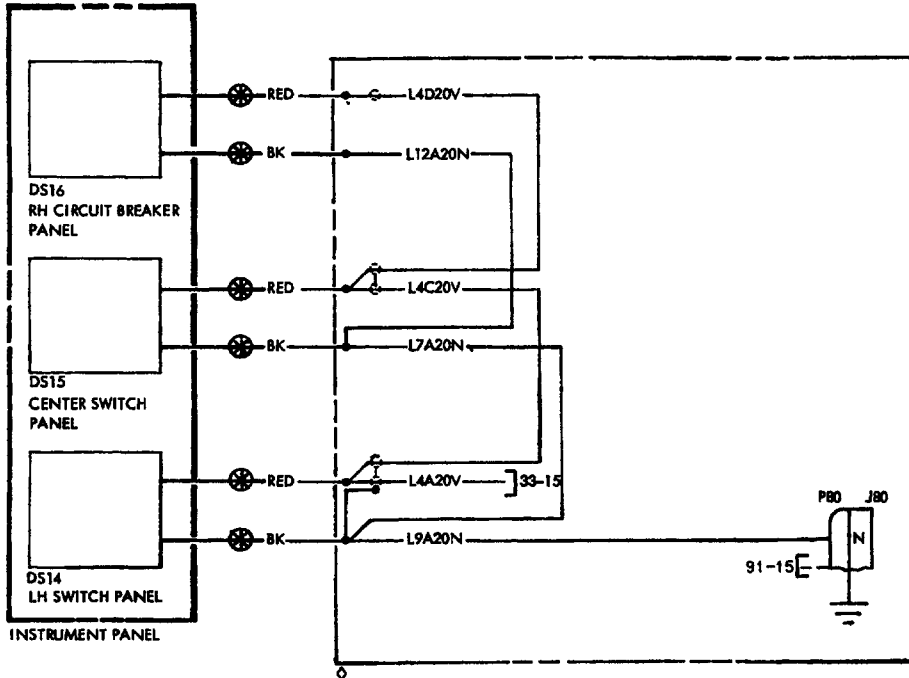

◇ WIRE AS SHOWN ON ACFT E-1787 & AFT; EA-174 & AFT; CE-934 & AFT; CJ-156 & AFT; D-10358 & AFT.

◇1 WIRE AS SHOWN ON ACFT E-1111, E-1241 THRU E-1786; EA-1 THRU EA-173; CE-748, CE-772 THRU CE-933; CJ-149 THRU CJ-155; D-10097, D-10120 THRU D-10357.

◆ FURNISHED WITH EQUIPMENT.

LIGHTS-ELECTROLUMINOUS PANEL

Beechcraft
BONANZA
WIRING DIAGRAM MANUAL

REFERENCE DESIGNATOR	PART NUMBER	DESCRIPTION	USABLE	
			INSTL	ON ZONE CODE
33-16-01				
DS14	35-380126-15	PANEL-SWITCH PANEL, LEFT	240	1
DS15	35-380133-55	PANEL-CENTER SWITCH	240	3
DS15	35-380133-19	PANEL-CENTER SWITCH	240	2
DS15	35-380133-53	PANEL-CENTER SWITCH	240	3
DS15	35-380133-57	PANEL-CENTER SWITCH	240	4
DS15	35-380133-59	PANEL-CENTER SWITCH	240	4
DS15	35-380133-65	PANEL-CENTER SWITCH	240	5
DS15	35-380133-63	PANEL-CENTER SWITCH	240	5
DS15	35-380133-67	PANEL-CENTER SWITCH	240	6
DS15	35-380133-69	PANEL-CENTER SWITCH	240	6
DS15	35-380133-61	PANEL-CENTER SWITCH	240	7
DS15	35-380133-71	PANEL-CENTER SWITCH	240	7
DS15	35-380133-73	PANEL-CENTER SWITCH	240	6
DS15	35-380133-75	PANEL-CENTER SWITCH	240	6
DS15	35-380133-79	PANEL-CENTER SWITCH	240	6
DS15	35-380133-81	PANEL-CENTER SWITCH	240	6
DS15	35-380133-77	PANEL-CENTER SWITCH	240	6
DS15	35-380133-83	PANEL-CENTER SWITCH	240	6
DS15	35-380133-85	PANEL-CENTER SWITCH	240	6
DS15	35-380133-87	PANEL-CENTER SWITCH	240	6
DS16	36-380019-9	PANEL-CIRCUIT BREAKER, RIGHT	240	8
DS16	36-380019-15	PANEL-CIRCUIT BREAKER, RIGHT	240	9
DS16	36-380019-23	PANEL-CIRCUIT BREAKER, RIGHT	240	10
DS16	36-380019-25	PANEL-CIRCUIT BREAKER, RIGHT	240	11
DS16	36-380019-33	PANEL-CIRCUIT BREAKER, RIGHT	240	12
DS16	36-380019-37	PANEL-CIRCUIT BREAKER, RIGHT	240	13
DS16	36-380019-35	PANEL-CIRCUIT BREAKER, RIGHT	240	14
DS16	36-380074-1	PANEL-CIRCUIT BREAKER, RIGHT	240	15
DS16	36-380074-3	PANEL-CIRCUIT BREAKER, RIGHT (WITHOUT AIR CONDITIONING)	240	16
DS16	36-380074-5	PANEL-CIRCUIT BREAKER, RIGHT (WITH AIR COND)	240	16
J80	204814-1	RECEPTACLE-GROUNDING BLOCK	231	1
P80A	200838-3	PLUG-GROUNDING BLOCK	231	1
P80B	201224-1	STRAIN RELIEF	231	1
P80C	201328-1	SOCKET CONTACT	231	1
P80D	200333-1	SOCKET CONTACT	231	1

Beechcraft BONANZA WIRING DIAGRAM MANUAL

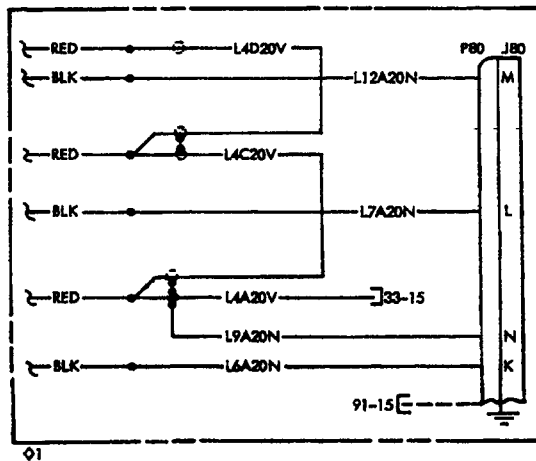
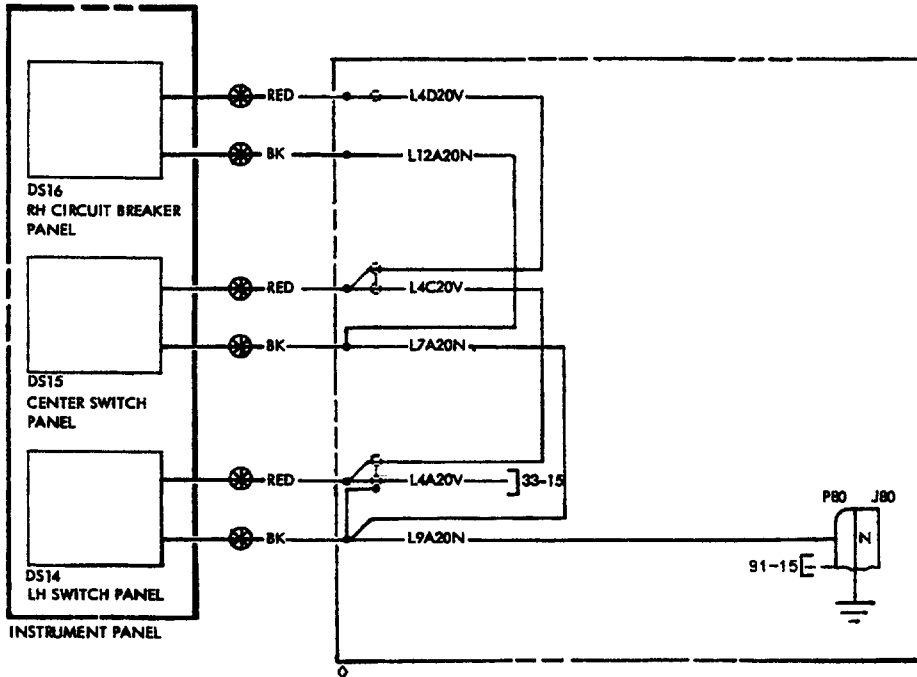

◇ WIRE AS SHOWN ON ACFT E-1787& AFT; EA-174& AFT; CE-934& AFT; CJ-156& AFT; D-10358& AFT.

◇1 WIRE AS SHOWN ON ACFT E-1111, E-1241 THRU E-1784; EA-1 THRU EA-173; CE-748, CE-772 THRU CE-933; CJ-149 THRU CJ-155; D-10097, D-10120 THRU D-10357.

◆ FURNISHED WITH EQUIPMENT.

LIGHTS-ELECTROLUMINOUS PANEL

Beechcraft
BONANZA
WIRING DIAGRAM MANUAL

REFERENCE DESIGNATOR	PART NUMBER	DESCRIPTION	USABLE INSTL ON ZONE CODE
33-16-01			
P80E	203618-1	JACKSCREW	231 1

EFFECTIVITY CODE

1. E-1111, E-1241 THRU E-1945, E-1947 THRU E-2103, E-2105 THRU E-2110; CE-748, CE-772 AND AFTER; CJ-149 AND AFTER; D-10097, D-10120 AND AFTER; EA-1 THRU EA-319, EA-321 THRU EA-388
2. E-1111, E-1241 THRU E-1370; CE-748, CE-772 THRU CE-815; CJ-149 ONLY; D-10097, D-10120 THRU D-10178
3. E-1371 THRU E-1931; CE-816 THRU CE-977; CJ-150 THRU CJ-155; D-10179 THRU D-10382
4. EA-1 THRU EA-241, EA-243 THRU EA-272
5. E-1932 THRU E-1945, E-1947 THRU E-1989; CE-978 THRU CE-989; CJ-156 AND AFTER; D-10383 THRU D-10389
6. EA-242, EA-273 THRU EA-319, EA-321 THRU EA-388
7. E-1988 THRU E-2103, E-2105 THRU E-2110; CE-990 AND AFTER; D-10390 AND AFTER
8. EA-1 THRU EA-5
9. E-1111, E-1241 THRU E-1423; CE-748, CE-772 THRU CE-833; D-10097, D-10120 THRU D-10205
10. E-1424 THRU E-1518; CE-834 THRU CE-912; D-10206 THRU D-10349
11. CJ-149 ONLY
12. E-1519 THRU E-1765; CE-913 THRU CE-928; D-10350 THRU D-10353
13. EA-6 THRU EA-51
14. CJ-150 THRU CJ-155; EA-52 THRU EA-158
15. E-1766 THRU E-1945, E-1947 THRU E-2103, E-2105 THRU E-2110; CE-929 AND AFTER; D-10354 AND AFTER
16. CJ-156 AND AFTER; EA-159 THRU EA-319, EA-321 THRU EA-388

Beechcraft
BONANZA
WIRING DIAGRAM MANUAL

33-17-01

**E-1111, E-1241 THRU E-1666; CE-748, CE-772 THRU CE-901; CJ-149
THRU CJ-155; D-10097, D-10120 THRU D-10342; EA-1 THRU EA-70**

Beechcraft BONANZA WIRING DIAGRAM MANUAL

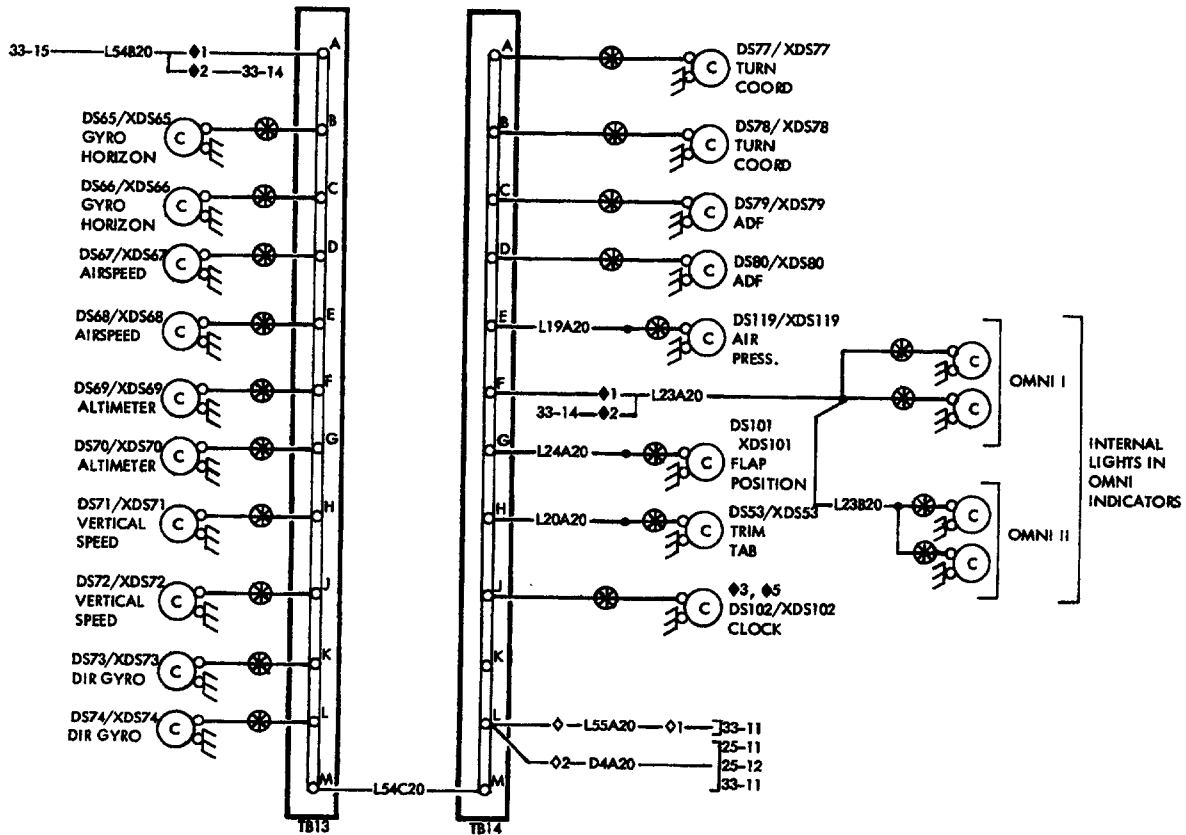

- ◇2 ON ACFT E-1519 & AFTER; EA-6 & AFTER; CE-862 & AFTER; CJ-150 & AFTER; D-10248 & AFTER.
- ◇1 ON ACFT E-1111, E-1241 THRU E-1518; EA-1 THRU EA-5; CE-748, CE-772 THRU CE-861; CJ-149; D-10097, D-10120 THRU D-10247.
- ◇ OPTIONAL EQUIPMENT.

- ◆1 ON AIRCRAFT HAVING OPTIONAL POST LIGHTS INSTALLED, WIRES L23A & L54B ARE ROUTED AS INDICATED.
- ◆2 ON AIRCRAFT HAVING OPTIONAL WEDGE LIGHTS INSTALLED, WIRES L23A & L54B ARE CONNECTED AS SHOWN ON DIAGRAM 33-14.
- ◆3 WHEN OPTIONAL CONTROL WHEEL CLOCK LIGHT, DS90 IS INSTALLED, THE STANDARD CLOCK LIGHT, DS102, IS OMITTED.
- ◆5 ON AIRCRAFT E-1111, E-1241 THRU E-1517, EA-1 THRU EA-5, CE-748, CE-772 THRU CE-861, CJ-149, D-10097 & D-10120 THRU D-10247.

LIGHTS-FLIGHT INSTRUMENTS POST (OPTIONAL)

Beechcraft BONANZA WIRING DIAGRAM MANUAL

REFERENCE DESIGNATOR	PART NUMBER	DESCRIPTION	INSTL	USABLE ON ZONE CODE
33-17-01				
DS101	327	INDICATOR LIGHT-FLAP POSITION (OPTL)	240	1
DS102	327	POST LIGHT-CLOCK (OPTL)	240	2
DS119	327	POST LIGHT-AIR PRESSURE (OPTL)	240	1
DS53A	1819	INDICATOR LIGHT-TRIM TAB (OPTL)	240	1
DS53B	D165-100-2	FILTER (OPTL)	240	1
DS65	327	POST LIGHT-GYRO HORIZON (OPTL)	240	1
DS66	327	POST LIGHT-GYRO HORIZON (OPTL)	240	1
DS67	327	POST LIGHT-AIRSPEED (OPTL)	240	1
DS68	327	POST LIGHT-AIRSPEED (OPTL)	240	1
DS69	327	POST LIGHT-ALTIMETER (OPTL)	240	1
DS70	327	POST LIGHT-ALTIMETER (OPTL)	240	1
DS71	327	POST LIGHT-VERTICAL SPEED (OPTL)	240	1
DS72	327	POST LIGHT-VERTICAL SPEED (OPTL)	240	1
DS73	327	POST LIGHT-DIRECTIONAL GYRO (OPTL)	240	1
DS74	327	POST LIGHT-DIRECTIONAL GYRO (OPTL)	240	1
DS77	327	POST LIGHT-TURN COORDINATOR (OPTL)	240	1
DS78	327	POST LIGHT-TURN COORDINATOR (OPTL)	240	1
DS79	327	POST LIGHT-AUTOMATIC DIRECTION FINDER (OPTL)	240	1
DS80	327	POST LIGHT-AUTOMATIC DIRECTION FINDER (OPTL)	240	1
DS90	267	LIGHT-CLOCK, CONTROL WHEEL (OPTL)	240	1
TB13A	204228-2	TERMINAL BOARD (OPTL)	240	1
TB13B	203669-6	PIN CONTACT (OPTL)	240	1
TB14A	204228-2	TERMINAL BOARD (OPTL)	240	1
TB14B	203669-6	PIN CONTACT (OPTL)	240	1
XDS101	A8970B2	LAMPHOLDER-FLAP POSITION LIGHT (OPTL)	240	1
XDS102	A8970B-2	LAMPHOLDER-CLOCK LIGHT (OPTL)	240	2
XDS119	A8970B2	LAMPHOLDER-AIR PRESSURE (OPTL)	240	1
XDS65	A8970B2	LAMPHOLDER-GYRO HORIZON	240	1
XDS66	A8970B2	LAMPHOLDER-GYRO HORIZON (OPTL)	240	1
XDS67	A8970B2	LAMPHOLDER-AIRSPEED (OPTL)	240	1
XDS68	A8970B2	LAMPHOLDER-AIRSPEED (OPTL)	240	1
XDS69	A8970B2	LAMPHOLDER-ALTIMETER (OPTL)	240	1
XDS70	A8970B2	LAMPHOLDER-ALTIMETER (OPTL)	240	1
XDS71	A8970B2	LAMPHOLDER-VERTICAL SPEED (OPTL)	240	1
XDS72	A8970B2	LAMPHOLDER-VERTICAL SPEED (OPTL)	240	1
XDS73	A8970B2	LAMPHOLDER-DIRECTIONAL GYRO (OPTL)	240	1
XDS74	A8970B2	LAMPHOLDER-DIRECTIONAL GYRO (OPTL)	240	1
XDS77	A8970B2	LAMPHOLDER-TURN COORDINATOR (OPTL)	240	1
XDS78	A8970B2	LAMPHOLDER-TURN COORDINATOR (OPTL)	240	1
XDS79	A8970B2	LAMPHOLDER-AUTOMATIC DIRECTION FINDER (OPTL)	240	1

Beechcraft BONANZA WIRING DIAGRAM MANUAL

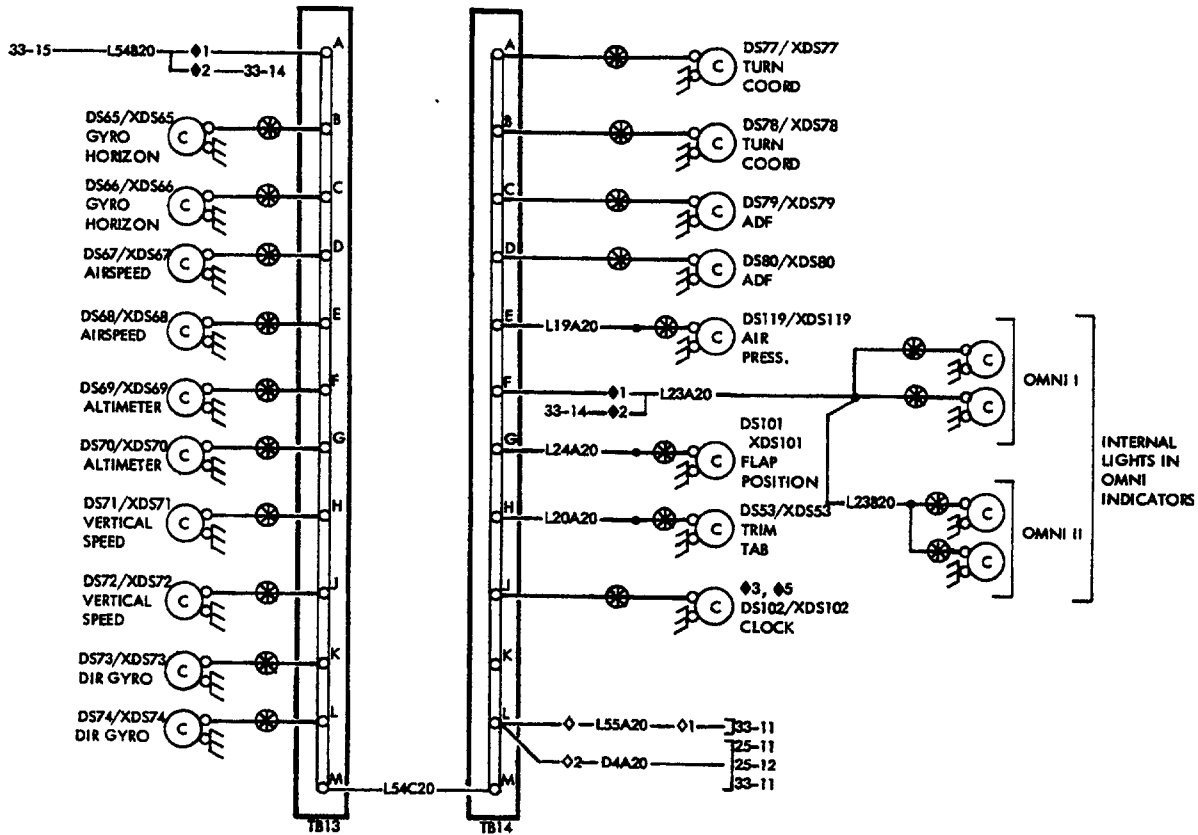

- ◊2 ON ACFT E-1519 & AFTER; EA-6 & AFTER; CE-862 & AFTER; CJ-150 & AFTER; D-10248 & AFTER.
- ◊1 ON ACFT E-1111, E-1241 THRU E-1518; EA-1 THRU EA-5; CE-748, CE-772 THRU CE-861; CJ-149; D-10097, D-10120 THRU D-10247.
- ◊ OPTIONAL EQUIPMENT.

- ◊1 ON AIRCRAFT HAVING OPTIONAL POST LIGHTS INSTALLED, WIRES L23A & L54B ARE ROUTED AS INDICATED.
- ◊2 ON AIRCRAFT HAVING OPTIONAL WEDGE LIGHTS INSTALLED, WIRES L23A & L54B ARE CONNECTED AS SHOWN ON DIAGRAM 33-14.
- ◊3 WHEN OPTIONAL CONTROL WHEEL CLOCK LIGHT, DS90 IS INSTALLED, THE STANDARD CLOCK LIGHT, DS102, IS OMITTED.
- ◊5 ON AIRCRAFT E-1111, E-1241 THRU E-1517, EA-1 THRU EA-5, CE-748, CE-772 THRU CE-861, CJ-149, D-10097 & D-10120 THRU D-10247.

LIGHTS-FLIGHT INSTRUMENTS POST (OPTIONAL)

Beechcraft
BONANZA
WIRING DIAGRAM MANUAL

REFERENCE DESIGNATOR	PART NUMBER	DESCRIPTION	USABLE	
			INSTL ZONE	ON CODE
33-17-01				
XDS80	A8970B2	LAMPHOLDER-AUTOMATIC DIRECTION FINDER (OPTL)	240	1

EFFECTIVITY CODE

1. E-1111, E-1241 THRU E-1666; CE-748, CE-772 THRU CE-901; CJ-149 THRU CJ-155; D-10097, D-10120 THRU D-10342; EA-1 THRU EA-70

2. E-1111, E-1241 THRU E-1517; CE-748, CE-772 THRU CE-861; CJ-149 ONLY; D-10097, D-10120 THRU D-10342; EA-1 THRU EA-5

Beechcraft
BONANZA
WIRING DIAGRAM MANUAL

33-17-02

**E-1667 THRU E-1945, E-1947 THRU E-1999; CE-902 THRU CE-993;
D-10343 THRU D-10391; EA-71 THRU EA-296**

Beechcraft BONANZA WIRING DIAGRAM MANUAL

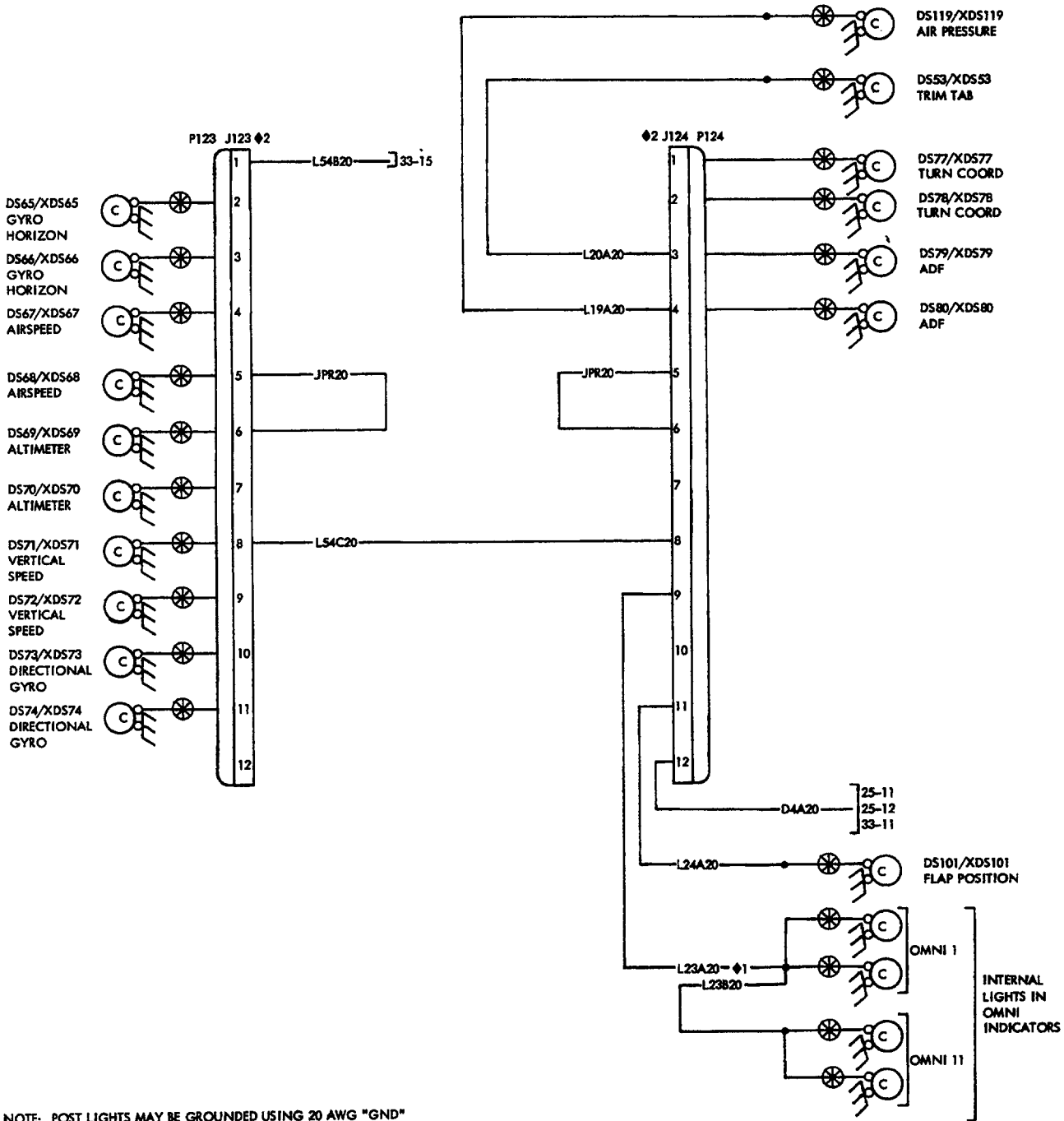

NOTE: POST LIGHTS MAY BE GROUNDED USING 20 AWG "GND" CODED OR BLACK JUMPER WIRES AS REQUIRED BETWEEN POST LIGHT MOUNTING STUDS. MAIN GROUND LEAD SHOULD TERMINATE IN GROUND PLUG.

◆1 ON ACFT HAVING OPTIONAL POST LIGHTS INSTALLED WIRES L23A & L54B ARE ROUTED AS INDICATED.

◆2 PIN HOUSING IS FILLED AND ALL PINS ARE BUSED TOGETHER.

LIGHTS-FLIGHT INSTRUMENTS POST (OPTIONAL)

Beechcraft
BONANZA
WIRING DIAGRAM MANUAL

REFERENCE DESIGNATOR	PART NUMBER	DESCRIPTION	USABLE	
			INSTL ZONE	ON CODE
33-17-02				
DS101	327	INDICATOR LIGHT-FLAP POSITION (OPTL)	240	1
DS119	327	POST LIGHT-AIR PRESSURE (OPTL)	240	1
DS53A	1819	INDICATOR LIGHT-TRIM TAB (OPTL)	240	1
DS53B	D165-100-2	FILTER (OPTL)	240	1
DS65	327	POST LIGHT-GYRO HORIZON (OPTL)	240	1
DS66	327	POST LIGHT-GYRO HORIZON (OPTL)	240	1
DS67	327	POST LIGHT-AIRSPEED (OPTL)	240	1
DS68	327	POST LIGHT-AIRSPEED (OPTL)	240	1
DS69	327	POST LIGHT-ALTIMETER (OPTL)	240	1
DS70	327	POST LIGHT-ALTIMETER (OPTL)	240	1
DS71	327	POST LIGHT-VERTICAL SPEED (OPTL)	240	1
DS72	327	POST LIGHT-VERTICAL SPEED (OPTL)	240	1
DS73	327	POST LIGHT-DIRECTIONAL GYRO (OPTL)	240	1
DS74	327	POST LIGHT-DIRECTIONAL GYRO (OPTL)	240	1
DS77	327	POST LIGHT-TURN COORDINATOR (OPTL)	240	1
DS78	327	POST LIGHT-TURN COORDINATOR (OPTL)	240	1
DS79	327	POST LIGHT-AUTOMATIC DIRECTION FINDER (OPTL)	240	1
DS80	327	POST LIGHT-AUTOMATIC DIRECTION FINDER (OPTL)	240	1
J123A	1-480288-0	RECEPTACLE-FLOATING PANEL, COMMON	240	1
J123B	350444-5	COMMON TAB	240	1
J123C	60618-1	PIN CONTACT	240	1
J124A	1-480288-0	RECEPTACLE-FLOATING PANEL, COMMON	240	1
J124B	350444-5	COMMON TAB	240	1
J124C	60618-1	PIN CONTACT	240	1
P123A	1-480287-0	PLUG-FLOATING PANEL, COMMON	240	1
P123B	60617-1	SOCKET CONTACT	240	1
P124A	1-480287-0	PLUG-FLOATING PANEL, COMMON	240	1
P124B	60617-1	SOCKET CONTACT	240	1
XDS101	A8970B2	LAMPHOLDER-FLAP POSITION LIGHT (OPTL)	240	1
XDS119	A8970B2	LAMPHOLDER-AIR PRESSURE (OPTL)	240	1
XDS53	PL-1	LAMPHOLDER-TRIM TAB LIGHT (OPTL)	240	1
XDS65	A8970B2	LAMPHOLDER-GYRO HORIZON	240	1
XDS66	A8970B2	LAMPHOLDER-GYRO HORIZON (OPTL)	240	1
XDS67	A8970B2	LAMPHOLDER-AIRSPEED (OPTL)	240	1
XDS68	A8970B2	LAMPHOLDER-AIRSPEED (OPTL)	240	1
XDS69	A8970B2	LAMPHOLDER-ALTIMETER (OPTL)	240	1
XDS70	A8970B2	LAMPHOLDER-ALTIMETER (OPTL)	240	1
XDS71	A8970B2	LAMPHOLDER-VERTICAL SPEED (OPTL)	240	1
XDS72	A8970B2	LAMPHOLDER-VERTICAL SPEED (OPTL)	240	1
XDS73	A8970B2	LAMPHOLDER-DIRECTIONAL GYRO (OPTL)	240	1
XDS74	A8970B2	LAMPHOLDER-DIRECTIONAL GYRO (OPTL)	240	1
XDS77	A8970B2	LAMPHOLDER-TURN COORDINATOR (OPTL)	240	1
XDS78	A8970B2	LAMPHOLDER-TURN COORDINATOR (OPTL)	240	1
XDS79	A8970B2	LAMPHOLDER-AUTOMATIC DIRECTION FINDER (OPTL)	240	1

Beechcraft BONANZA WIRING DIAGRAM MANUAL

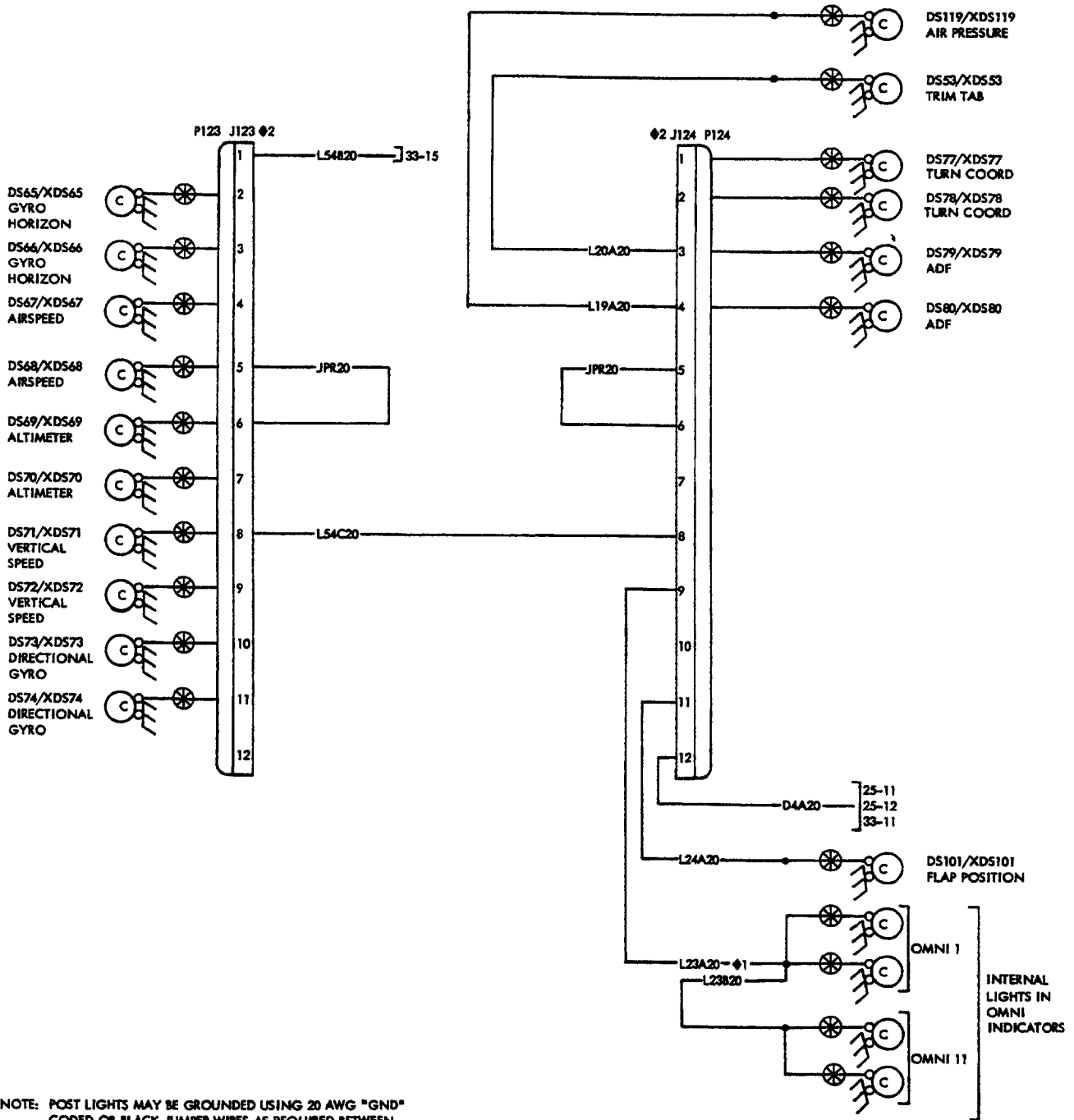

NOTE: POST LIGHTS MAY BE GROUNDED USING 20 AWG "GND" COOED OR BLACK JUMPER WIRES AS REQUIRED BETWEEN POST LIGHT MOUNTING STUDS. MAIN GROUND LEAD SHOULD TERMINATE IN GROUND PLUG.

- ♦1 ON ACFT HAVING OPTIONAL POST LIGHTS INSTALLED WIRES L23A & L54B ARE ROUTED AS INDICATED.
- ♦2 PIN HOUSING IS FILLED AND ALL PINS ARE BUSED TOGETHER.

LIGHTS-FLIGHT INSTRUMENTS POST (OPTIONAL)

Beechcraft
BONANZA
WIRING DIAGRAM MANUAL

REFERENCE DESIGNATOR	PART NUMBER	DESCRIPTION	USABLE INSTL ON ZONE CODE
33-17-02			
XDS80	A8970B2	LAMPHOLDER-AUTOMATIC DIRECTION FINDER (OPTL)	240 1

EFFECTIVITY CODE

1. E-1667 THRU E-1945, E-1947 THRU E-1999; CE-902 THRU CE-993; D-10343 THRU D-10391;
EA-71 THRU EA-296

Beechcraft
BONANZA
WIRING DIAGRAM MANUAL

33-17-03

**E-2000 THRU E-2103, E-2105 THRU E-2110; CE-994 AND AFTER;
CJ-156 AND AFTER; D-10392 AND AFTER; EA-297 THRU EA-319,
EA-321 THRU EA-388**

Beechcraft BONANZA WIRING DIAGRAM MANUAL

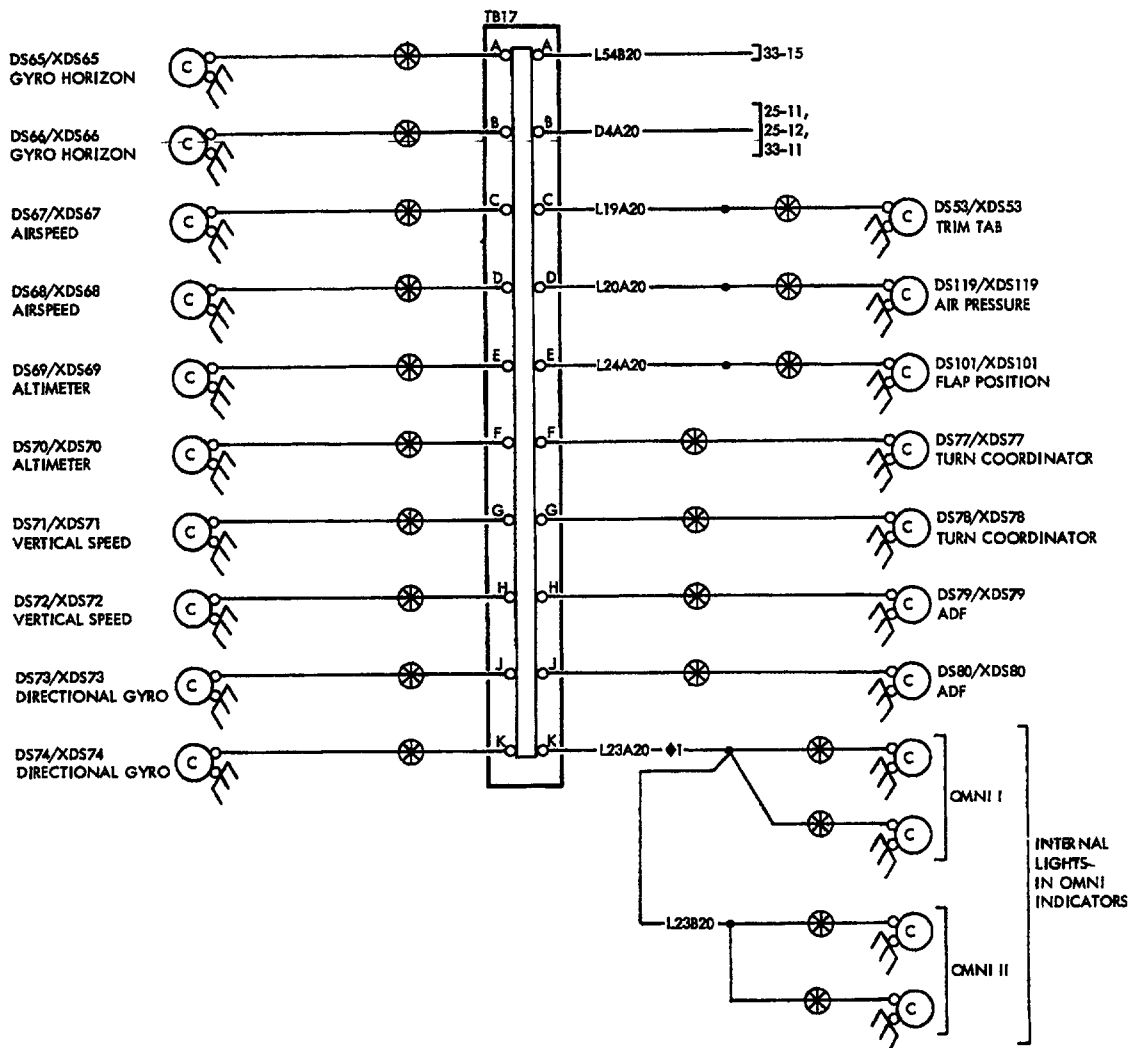

NOTE: DUE TO PANEL MODIFICATIONS, LIGHTS MAY BE MOVED TO DIFFERENT TERMINAL BLOCKS TO MAINTAIN PROPER GROUP DIMMING.

NOTE: POST LIGHTS MAY BE GROUNDED USING 20 AWG "GND" CODED OR BLACK JUMPER WIRES AS REQUIRED BETWEEN POST LIGHT MOUNTING STUDS. MAIN GROUND LEAD SHOULD TERMINATE IN GROUND PLUG.

◆1 ON ACFT HAVING OPTIONAL POST LIGHTS INSTALLED WIRES L23A & L54B ARE ROUTED AS INDICATED.

LIGHTS-FLIGHT INSTRUMENTS POST (OPTIONAL)

Beechcraft BONANZA WIRING DIAGRAM MANUAL

REFERENCE DESIGNATOR	PART NUMBER	DESCRIPTION	INSTL ZONE	USABLE ON CODE
33-17-03				
DS101	327	INDICATOR LIGHT-FLAP POSITION (OPTL)	240	1
DS119	327	POST LIGHT-AIR PRESSURE (OPTL)	240	1
DS53A	1819	INDICATOR LIGHT-TRIM TAB (OPTL)	240	1
DS53B	D165-100-2	FILTER (OPTL)	240	1
DS65	327	POST LIGHT-GYRO HORIZON (OPTL)	240	1
DS66	327	POST LIGHT-GYRO HORIZON (OPTL)	240	1
DS67	327	POST LIGHT-AIRSPEED (OPTL)	240	1
DS68	327	POST LIGHT-AIRSPEED (OPTL)	240	1
DS69	327	POST LIGHT-ALTIMETER (OPTL)	240	1
DS70	327	POST LIGHT-ALTIMETER (OPTL)	240	1
DS71	327	POST LIGHT-VERTICAL SPEED (OPTL)	240	1
DS72	327	POST LIGHT-VERTICAL SPEED (OPTL)	240	1
DS73	327	POST LIGHT-DIRECTIONAL GYRO (OPTL)	240	1
DS74	327	POST LIGHT-DIRECTIONAL GYRO (OPTL)	240	1
DS77	327	POST LIGHT-TURN COORDINATOR (OPTL)	240	1
DS78	327	POST LIGHT-TURN COORDINATOR (OPTL)	240	1
DS79	327	POST LIGHT-AUTOMATIC DIRECTION FINDER (OPTL)	240	1
DS80	327	POST LIGHT-AUTOMATIC DIRECTION FINDER (OPTL)	240	1
TB17	M81714/7-AA1	TERMINAL JUNCTION INSTALLATION LIGHTS (POST)	240	1
XDS101	A8970B2	LAMPHOLDER-FLAP POSITION LIGHT (OPTL)	240	1
XDS119	A8970B2	LAMPHOLDER-AIR PRESSURE (OPTL)	240	1
XDS53	PL-1	LAMPHOLDER-TRIM TAB LIGHT (OPTL)	240	1
XDS65	A8970B2	LAMPHOLDER-GYRO HORIZON	240	1
XDS66	A8970B2	LAMPHOLDER-GYRO HORIZON (OPTL)	240	1
XDS67	A8970B2	LAMPHOLDER-AIRSPEED (OPTL)	240	1
XDS68	A8970B2	LAMPHOLDER-AIRSPEED (OPTL)	240	1
XDS69	A8970B2	LAMPHOLDER-ALTIMETER (OPTL)	240	1
XDS70	A8970B2	LAMPHOLDER-ALTIMETER (OPTL)	240	1
XDS71	A8970B2	LAMPHOLDER-VERTICAL SPEED (OPTL)	240	1
XDS72	A8970B2	LAMPHOLDER-VERTICAL SPEED (OPTL)	240	1
XDS73	A8970B2	LAMPHOLDER-DIRECTIONAL GYRO (OPTL)	240	1
XDS74	A8970B2	LAMPHOLDER-DIRECTIONAL GYRO (OPTL)	240	1
XDS77	A8970B2	LAMPHOLDER-TURN COORDINATOR (OPTL)	240	1
XDS78	A8970B2	LAMPHOLDER-TURN COORDINATOR (OPTL)	240	1
XDS79	A8970B2	LAMPHOLDER-AUTOMATIC DIRECTION FINDER (OPTL)	240	1
XDS80	A8970B2	LAMPHOLDER-AUTOMATIC DIRECTION FINDER (OPTL)	240	1

EFFECTIVITY CODE

1. E-2000 THRU E-2103, E-2105 THRU E-2110; CE-994 AND AFTER; CJ-156 AND AFTER; D-10392 AND AFTER; EA-297 THRU EA-319, EA-321 THRU EA-388

Beechcraft
BONANZA
WIRING DIAGRAM MANUAL

33-18-01

Configuration 1

**E-1111, E-1241 THRU E-1945, E-1947 THRU E-2103, E-2105 THRU
E-2110; CE-748, CE-772 THRU CE-1300, CE-1302 THRU CE-1306;
CJ-149 THRU CJ-179; D-10097, D-10120 AND AFTER; EA-1 THRU
EA-319, EA-321 THRU EA-388**

Beechcraft BONANZA WIRING DIAGRAM MANUAL

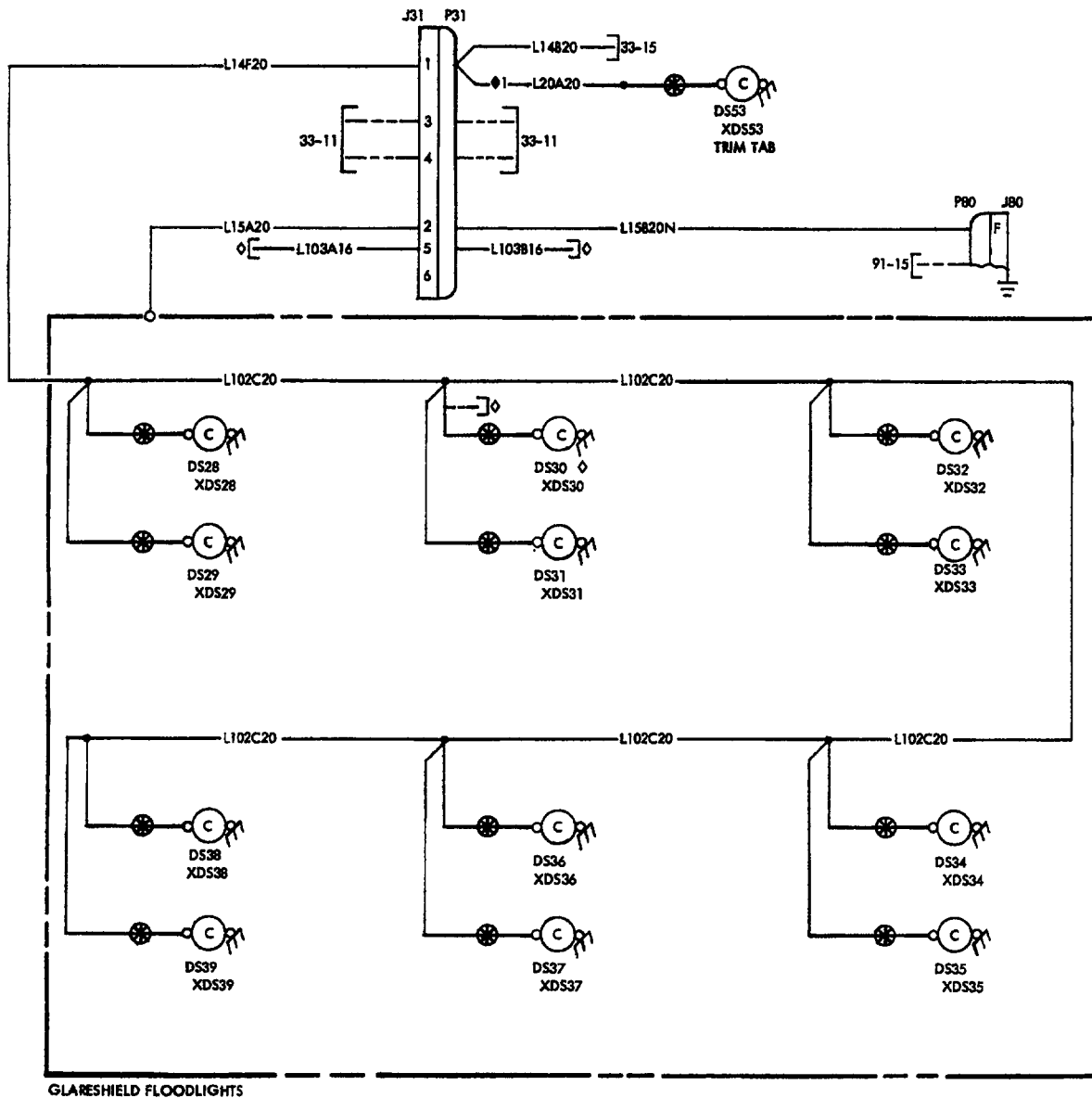

GLARESHIELD FLOODLIGHTS

◆1 WHEN OPTIONAL INSTRUMENT FLIGHT DIMMING IS USED REF TO DIAG 33-14 OR 33-17 FOR ROUTING OF WIRE L20A.

◇ WHEN OPTIONAL DUAL NAV/COMM IS USED REF 24-33. WHEN OPTIONAL SINGLE NAV/COMM IS USED REF 24-34.

LIGHTS-FLOOD (Configuration 1)

Beechcraft BONANZA WIRING DIAGRAM MANUAL

REFERENCE DESIGNATOR	PART NUMBER	DESCRIPTION	USABLE	
			INSTL ZONE	ON CODE
33-18-01 (Configuration 1)				
DS28A	313	BULB-FLOODLIGHT, GLARESHIELD	240	1
DS28B	D165-100-2	FILTER	240	1
DS29A	313	BULB-FLOODLIGHT, GLARESHIELD	240	1
DS29B	D165-100-2	FILTER	240	1
DS30A	313	BULB-FLOODLIGHT, GLARESHIELD	240	1
DS30B	D165-100-2	FILTER	240	1
DS31A	313	BULB-FLOODLIGHT, GLARESHIELD	240	1
DS31B	D165-100-2	FILTER	240	1
DS32A	313	BULB-FLOODLIGHT, GLARESHIELD	240	1
DS32B	D165-100-2	FILTER	240	1
DS33A	313	BULB-FLOODLIGHT, GLARESHIELD	240	1
DS33B	D165-100-2	FILTER	240	1
DS34A	313	BULB-FLOODLIGHT, GLARESHIELD	240	1
DS34B	D165-100-2	FILTER	240	1
DS35A	313	BULB-FLOODLIGHT, GLARESHIELD	240	1
DS35B	D165-100-2	FILTER	240	1
DS36A	313	BULB-FLOODLIGHT, GLARESHIELD	240	1
DS36B	D165-100-2	FILTER	240	1
DS37A	313	BULB-FLOODLIGHT, GLARESHIELD	240	1
DS37B	D165-100-2	FILTER	240	1
DS38A	313	BULB-FLOODLIGHT, GLARESHIELD	240	1
DS38B	D165-100-2	FILTER	240	1
DS39A	313	BULB-FLOODLIGHT, GLARESHIELD	240	1
DS39B	D165-100-2	FILTER	240	1
DS53A	1819	INDICATOR LIGHT-TRIM TAB (OPTL)	240	1
DS53B	D165-100-2	FILTER (OPTL)	240	1
J31A	1-480340-0	RECEPTACLE HOUSING-GLARESHIELD	231	1
J31B	60618-1	PIN CONTACT	231	1
J80	204814-1	RECEPTACLE-GROUNDING BLOCK	231	1
P31A	1-480270-0	SOCKET HOUSING-GLARESHIELD	231	1
P31B	60617-1	SOCKET CONTACT	231	1
P80A	200838-3	PLUG-GROUNDING BLOCK	231	1
P80B	201224-1	STRAIN RELIEF	231	1
P80C	201328-1	SOCKET CONTACT	231	1
P80D	200333-1	SOCKET CONTACT	231	1
P80E	203618-1	JACKSCREW	231	1
XDS28	4169-143	LAMPHOLDER-GLARESHIELD FLOODLIGHT	240	1
XDS29	4169-143	LAMPHOLDER-GLARESHIELD FLOODLIGHT	240	1
XDS30	4169-143	LAMPHOLDER-GLARESHIELD FLOODLIGHT	240	1
XDS31	4169-143	LAMPHOLDER-GLARESHIELD FLOODLIGHT	240	1
XDS32	4169-143	LAMPHOLDER-GLARESHIELD FLOODLIGHT	240	1
XDS33	4169-143	LAMPHOLDER-GLARESHIELD FLOODLIGHT	240	1
XDS34	4169-143	LAMPHOLDER-GLARESHIELD FLOODLIGHT	240	1
XDS35	4169-143	LAMPHOLDER-GLARESHIELD FLOODLIGHT	240	1
XDS36	4169-143	LAMPHOLDER-GLARESHIELD FLOODLIGHT	240	1
XDS37	4169-143	LAMPHOLDER-GLARESHIELD FLOODLIGHT	240	1
XDS38	4169-143	LAMPHOLDER-GLARESHIELD FLOODLIGHT	240	1
XDS39	4169-143	LAMPHOLDER-GLARESHIELD FLOODLIGHT	240	1

Beechcraft BONANZA WIRING DIAGRAM MANUAL

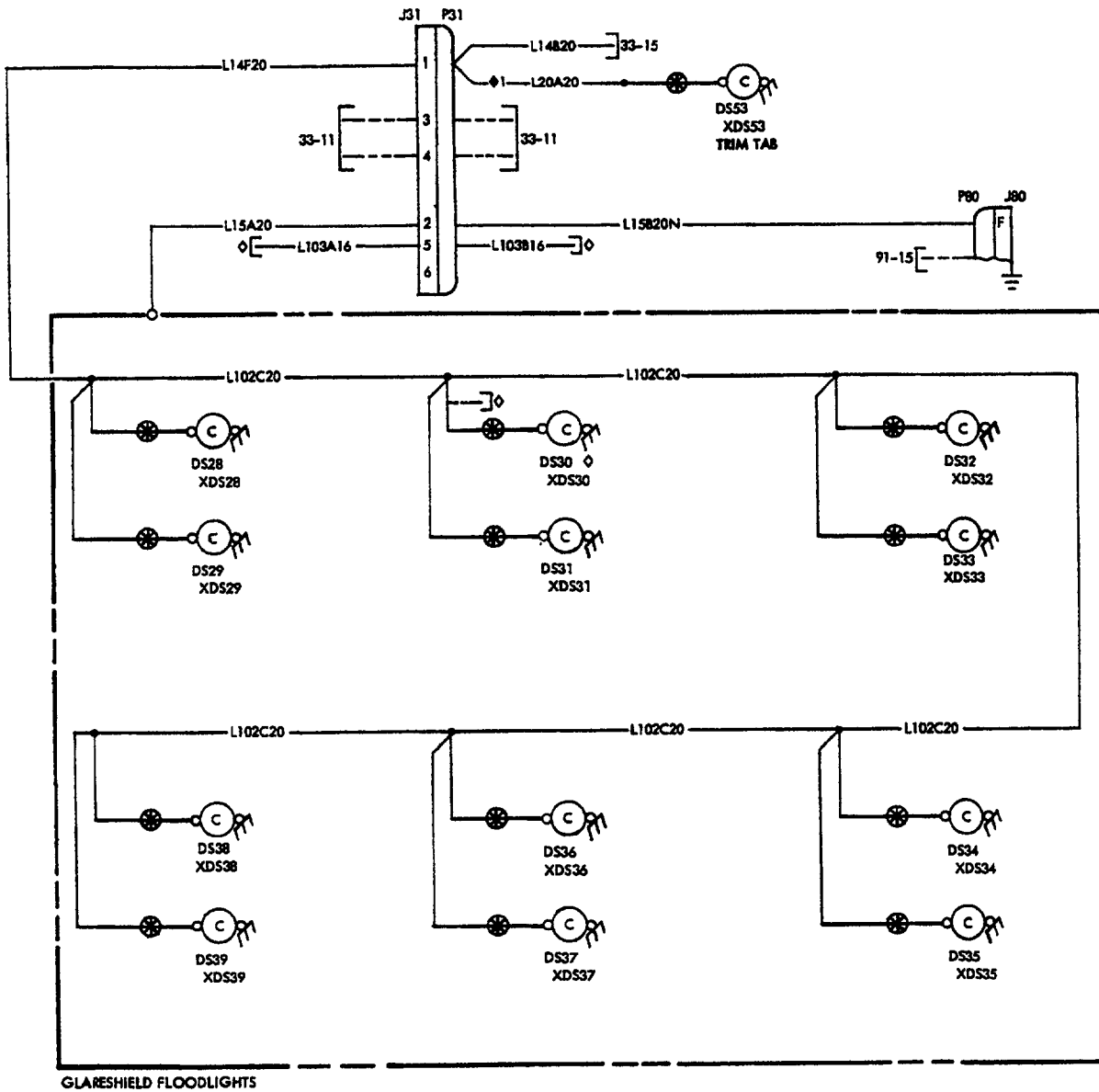

GLARESHIELD FLOODLIGHTS

◆1 WHEN OPTIONAL INSTRUMENT FLIGHT DIMMING IS USED REF TO DIAG 33-14 OR 33-17 FOR ROUTING OF WIRE L20A.

◇ WHEN OPTIONAL DUAL NAV/COMM IS USED REF 24-33. WHEN OPTIONAL SINGLE NAV/COMM IS USED REF 24-34.

LIGHTS-FLOOD (Configuration 1)

Beechcraft
BONANZA
WIRING DIAGRAM MANUAL

REFERENCE DESIGNATOR	PART NUMBER	DESCRIPTION	USABLE	
			INSTL	ON ZONE CODE
		33-18-01 (Configuration 1)		
XDS53	PL-1	LAMPHOLDER-TRIM TAB LIGHT (OPTL)	240	1

EFFECTIVITY CODE

1. E-1111, E-1241 THRU E-1945, E-1947 THRU E-2103, E-2105 THRU E-2110; CE-748, CE-772 THRU CE-1300, CE-1302 THRU CE-1306; CJ-149 THRU CJ-179; D-10097, D-10120 AND AFTER; EA-1 THRU EA-319, EA-321 THRU EA-388

Beechcraft
BONANZA
WIRING DIAGRAM MANUAL

33-18-01

Configuration 2

CE-1301, CE-1307 AND AFTER; CJ-180 AND AFTER

Beechcraft BONANZA WIRING DIAGRAM MANUAL

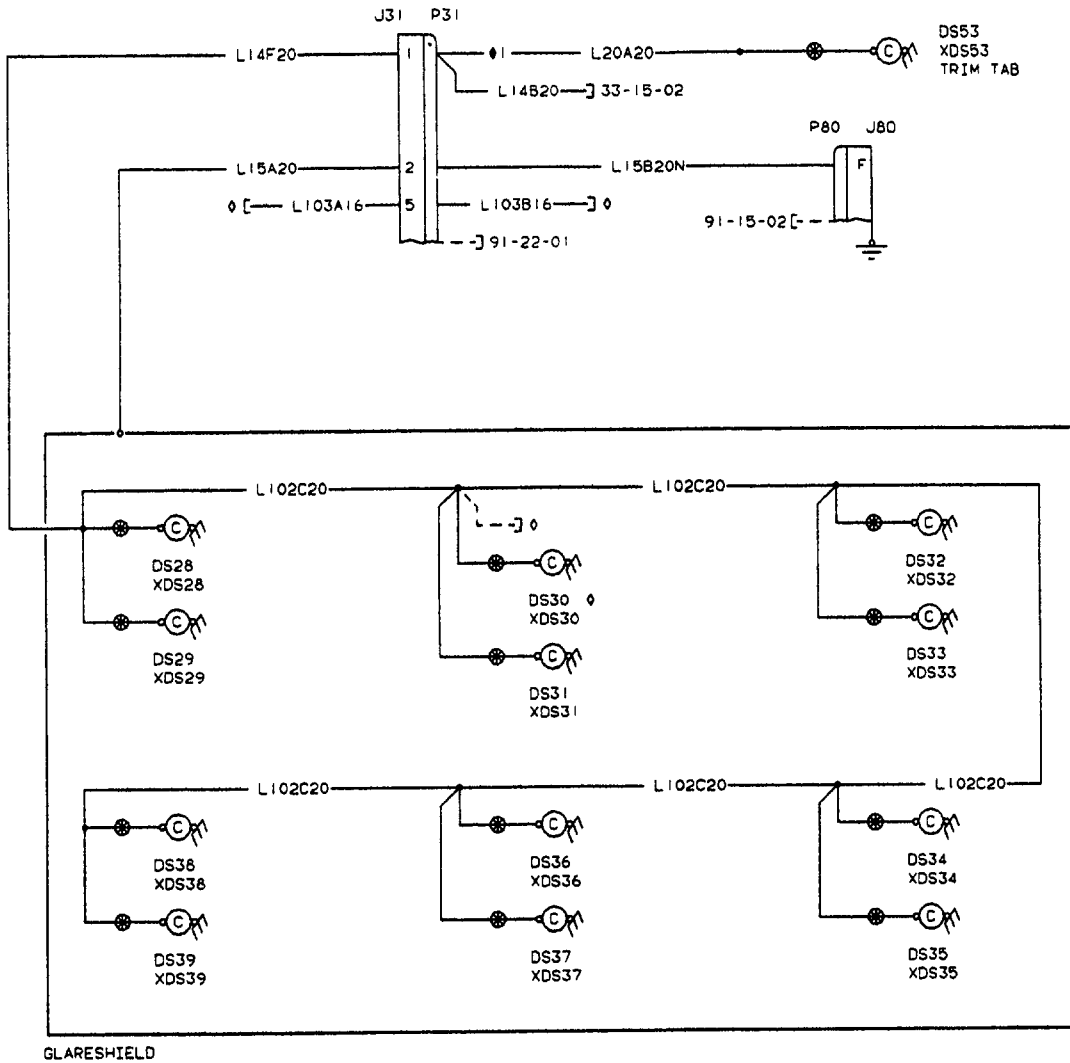

◊ ON AIRCRAFT HAVING OPTIONAL DIGITAL WHEEL CLOCK INSTALLED

◊ OPTIONAL EQUIPMENT

LIGHTS-FLOOD (Configuration 2)

Beechcraft
BONANZA
WIRING DIAGRAM MANUAL

REFERENCE DESIGNATOR	PART NUMBER	DESCRIPTION	USABLE	
			INSTL	ON ZONE CODE
33-18-01 (Configuration 2)				
DS28A	313	BULB-FLOODLIGHT, GLARESHIELD	240	1
DS28B	D165-100-2	FILTER	240	1
DS29A	313	BULB-FLOODLIGHT, GLARESHIELD	240	1
DS29B	D165-100-2	FILTER	240	1
DS30A	313	BULB-FLOODLIGHT, GLARESHIELD	240	1
DS30B	D165-100-2	FILTER	240	1
DS31A	313	BULB-FLOODLIGHT, GLARESHIELD	240	1
DS31B	D165-100-2	FILTER	240	1
DS32A	313	BULB-FLOODLIGHT, GLARESHIELD	240	1
DS32B	D165-100-2	FILTER	240	1
DS33A	313	BULB-FLOODLIGHT, GLARESHIELD	240	1
DS33B	D165-100-2	FILTER	240	1
DS34A	313	BULB-FLOODLIGHT, GLARESHIELD	240	1
DS34B	D165-100-2	FILTER	240	1
DS35A	313	BULB-FLOODLIGHT, GLARESHIELD	240	1
DS35B	D165-100-2	FILTER	240	1
DS36A	313	BULB-FLOODLIGHT, GLARESHIELD	240	1
DS36B	D165-100-2	FILTER	240	1
DS37A	313	BULB-FLOODLIGHT, GLARESHIELD	240	1
DS37B	D165-100-2	FILTER	240	1
DS38A	313	BULB-FLOODLIGHT, GLARESHIELD	240	1
DS38B	D165-100-2	FILTER	240	1
DS39A	313	BULB-FLOODLIGHT, GLARESHIELD	240	1
DS39B	D165-100-2	FILTER	240	1
DS53A	1819	INDICATOR LIGHT-TRIM TAB (OPTL)	240	1
DS53B	D165-100-2	FILTER (OPTL)	240	1
J31A	1-480340-0	RECEPTACLE HOUSING-GLARESHIELD	231	1
J31B	60618-1	PIN CONTACT	231	1
J80	204814-1	RECEPTACLE-GROUNDING BLOCK	231	1
P31A	1-480270-0	SOCKET HOUSING-GLARESHIELD	231	1
P31B	60617-1	SOCKET CONTACT	231	1
P80A	200838-3	PLUG-GROUNDING BLOCK	231	1
P80B	201224-1	STRAIN RELIEF	231	1
P80C	201328-1	SOCKET CONTACT	231	1
P80D	200333-1	SOCKET CONTACT	231	1
P80E	203618-1	JACKSCREW	231	1
XDS28	4169-143	LAMPHOLDER-GLARESHIELD FLOODLIGHT	240	1
XDS29	4169-143	LAMPHOLDER-GLARESHIELD FLOODLIGHT	240	1
XDS30	4169-143	LAMPHOLDER-GLARESHIELD FLOODLIGHT	240	1
XDS31	4169-143	LAMPHOLDER-GLARESHIELD FLOODLIGHT	240	1
XDS32	4169-143	LAMPHOLDER-GLARESHIELD FLOODLIGHT	240	1
XDS33	4169-143	LAMPHOLDER-GLARESHIELD FLOODLIGHT	240	1
XDS34	4169-143	LAMPHOLDER-GLARESHIELD FLOODLIGHT	240	1
XDS35	4169-143	LAMPHOLDER-GLARESHIELD FLOODLIGHT	240	1
XDS36	4169-143	LAMPHOLDER-GLARESHIELD FLOODLIGHT	240	1
XDS37	4169-143	LAMPHOLDER-GLARESHIELD FLOODLIGHT	240	1
XDS38	4169-143	LAMPHOLDER-GLARESHIELD FLOODLIGHT	240	1
XDS39	4169-143	LAMPHOLDER-GLARESHIELD FLOODLIGHT	240	1

Beechcraft BONANZA WIRING DIAGRAM MANUAL

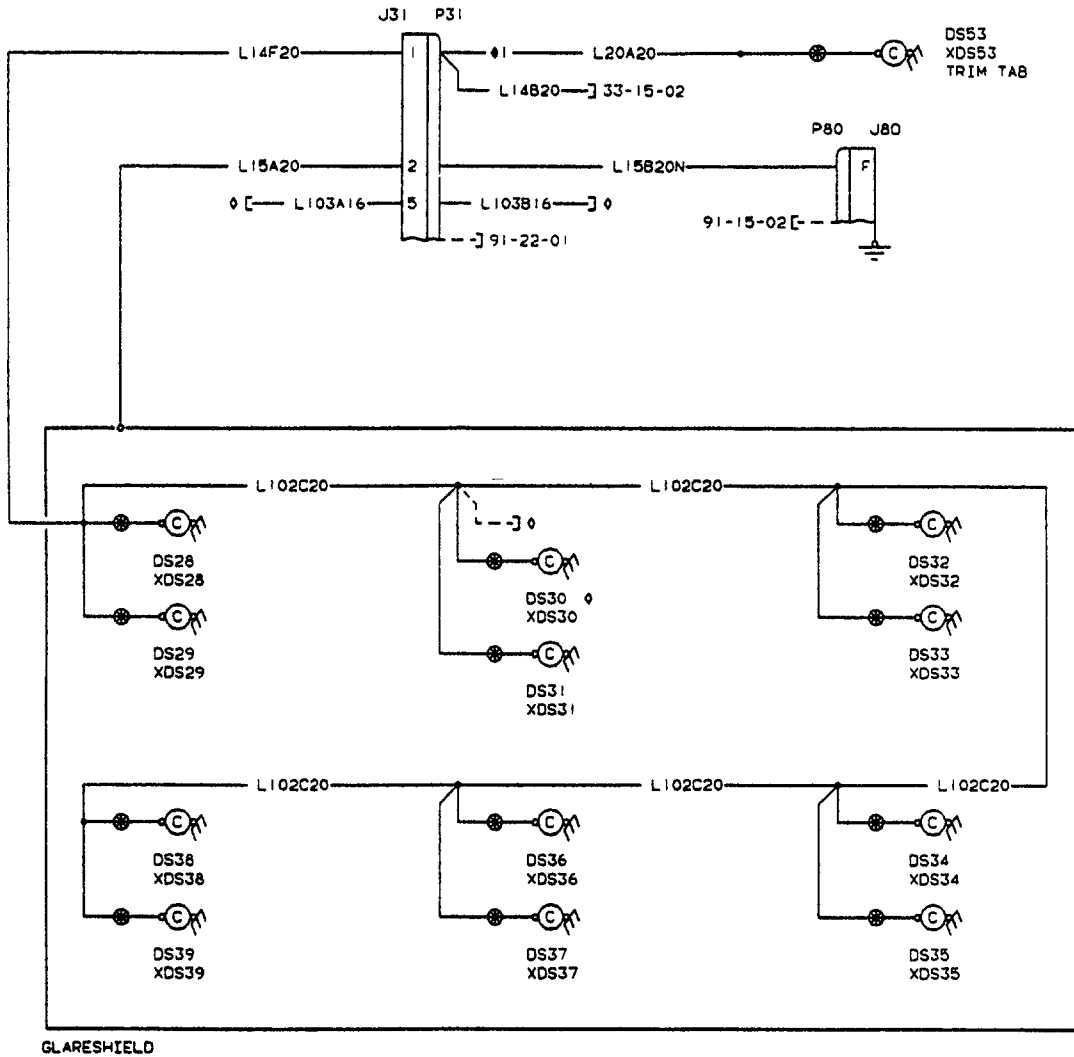

GLARESHIELD

◊ ON AIRCRAFT HAVING OPTIONAL DIGITAL WHEEL CLOCK INSTALLED

◊1 OPTIONAL EQUIPMENT

LIGHTS-FLOOD (Configuration 2)

Beechcraft
BONANZA
WIRING DIAGRAM MANUAL

REFERENCE DESIGNATOR	PART NUMBER	DESCRIPTION	USABLE	
			INSTL	ON ZONE CODE
XDS53	PL-1	33-18-01 (Configuration 2) LAMPHOLDER-TRIM TAB LIGHT (OPTL)	240	1

EFFECTIVITY CODE

1. CE-1301, CE-1307 AND AFTER; CJ-180 AND AFTER

Beechcraft
BONANZA
WIRING DIAGRAM MANUAL

33-20-01

**E-1111,E-1241 THRU E-1421,E-1423 THRU E-1550,E-1552 THRU
E-1568,E-1570 THRU E-1580,E-1582 THRU E-1593;CE-748,CE-772
THRU CE-918,CE-920 THRU CE-922,CE-924,CE-926,CE-928;CJ-149
THRU CJ-155;D-10097, D-10120 THRU D-10347,D-10349 THRU
D-10352;EA-1 THRU EA-20,EA-22 THRU EA-27, EA-29 THRU EA-32**

Beechcraft BONANZA WIRING DIAGRAM MANUAL

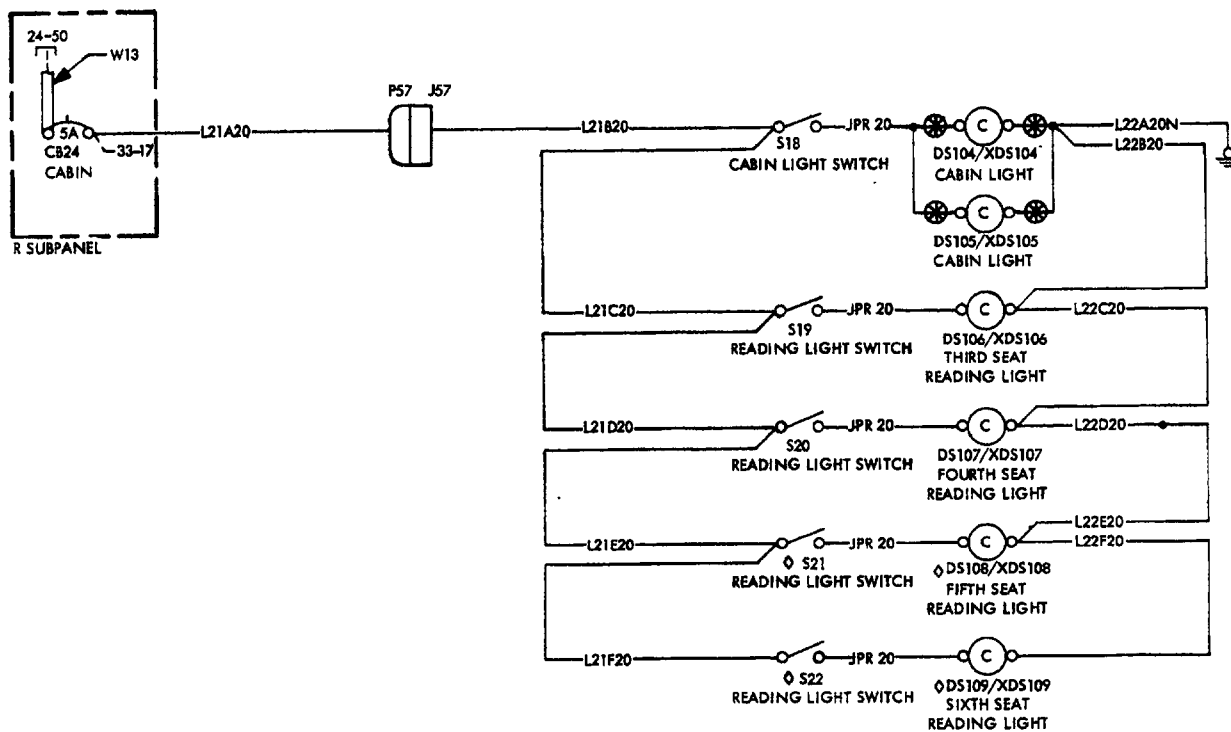

◇ OPTIONAL EQUIPMENT.

LIGHTS-CABIN

Beechcraft
BONANZA
WIRING DIAGRAM MANUAL

REFERENCE DESIGNATOR	PART NUMBER	DESCRIPTION	USABLE	
			INSTL ZONE	ON CODE
33-20-01				
CB24	435-205-104	CIRCUIT BREAKER-CABIN AND MAP LIGHT	240	1
DS104	1864	BULB-CABIN LIGHT	253	1
DS105	1864	BULB-CABIN LIGHT	253	1
DS106	303	BULB-READING LIGHT, THIRD SEAT	253	1
DS107	303	BULB-READING LIGHT, FOURTH SEAT	253	1
DS108	303	BULB-READING LIGHT, FIFTH SEAT (OPTL)	253	1
DS109	303	BULB-READING LIGHT, SIXTH SEAT (OPTL)	253	1
J57A	1-480351-0	RECEPTACLE-CABIN LIGHT	252	1
J57B	60618-1	PIN CONTACT	252	1
P57A	1-480349-0	PLUG-CABIN LIGHT	252	1
P57B	60617-1	SOCKET CONTACT	252	1
S18	L18366-3	SWITCH-CABIN LIGHT	253	1
S19	L18366-3	SWITCH-THIRD SEAT READING LIGHT	253	1
S20	L18366-3	SWITCH-FOURTH SEAT READING LIGHT	253	1
S21	L18366-3	SWITCH-FIFTH SEAT READING LIGHT (OPTL)	253	1
S22	L18366-3	SWITCH-SIXTH SEAT READING LIGHT (OPTL)	253	1
W13	114931-1-12	BUS-MAIN	240	1
XDS104	2506	LAMPHOLDER-CABIN LIGHT	253	1
XDS105	2506	LAMPHOLDER-CABIN LIGHT	253	1
XDS106	2565	LAMPHOLDER-THIRD READING LIGHT	253	1
XDS107	2565	LAMPHOLDER-FOURTH READING LIGHT	253	1
XDS108	2565	LAMPHOLDER-FIFTH SEAT READING LIGHT (OPTL)	253	1
XDS109	2565	LAMPHOLDER-SIXTH SEAT READING LIGHT (OPTL)	253	1

EFFECTIVITY CODE

1. E-1111,E-1241 THRU E-1421,E-1423 THRU E-1550,E-1552 THRU E-1568,E-1570 THRU
E-1580,E-1582 THRU E-1593;CE-748,CE-772 THRU CE-918,CE-920 THRU
CE-922,CE-924,CE-926,CE-928;CJ-149 THRU CJ-155;D-10097, D-10120 THRU D-10347,D-10349
THRU D-10352;EA-1 THRU EA-20,EA-22 THRU EA-27,EA-29 THRU EA-32

Beechcraft
BONANZA
WIRING DIAGRAM MANUAL

33-20-02

**E-1422, E-1551, E-1569, E-1594 THRU E-1945, E-1947 THRU E-2103,
E-2105 THRU E-2110; CE-919, CE-923, CE-925, CE-927, CE-929 AND
AFTER; CJ-156 AND AFTER; D-10348, D-10353 AND AFTER; EA-33
THRU EA-319, EA-321 THRU EA-388**

Beechcraft BONANZA WIRING DIAGRAM MANUAL

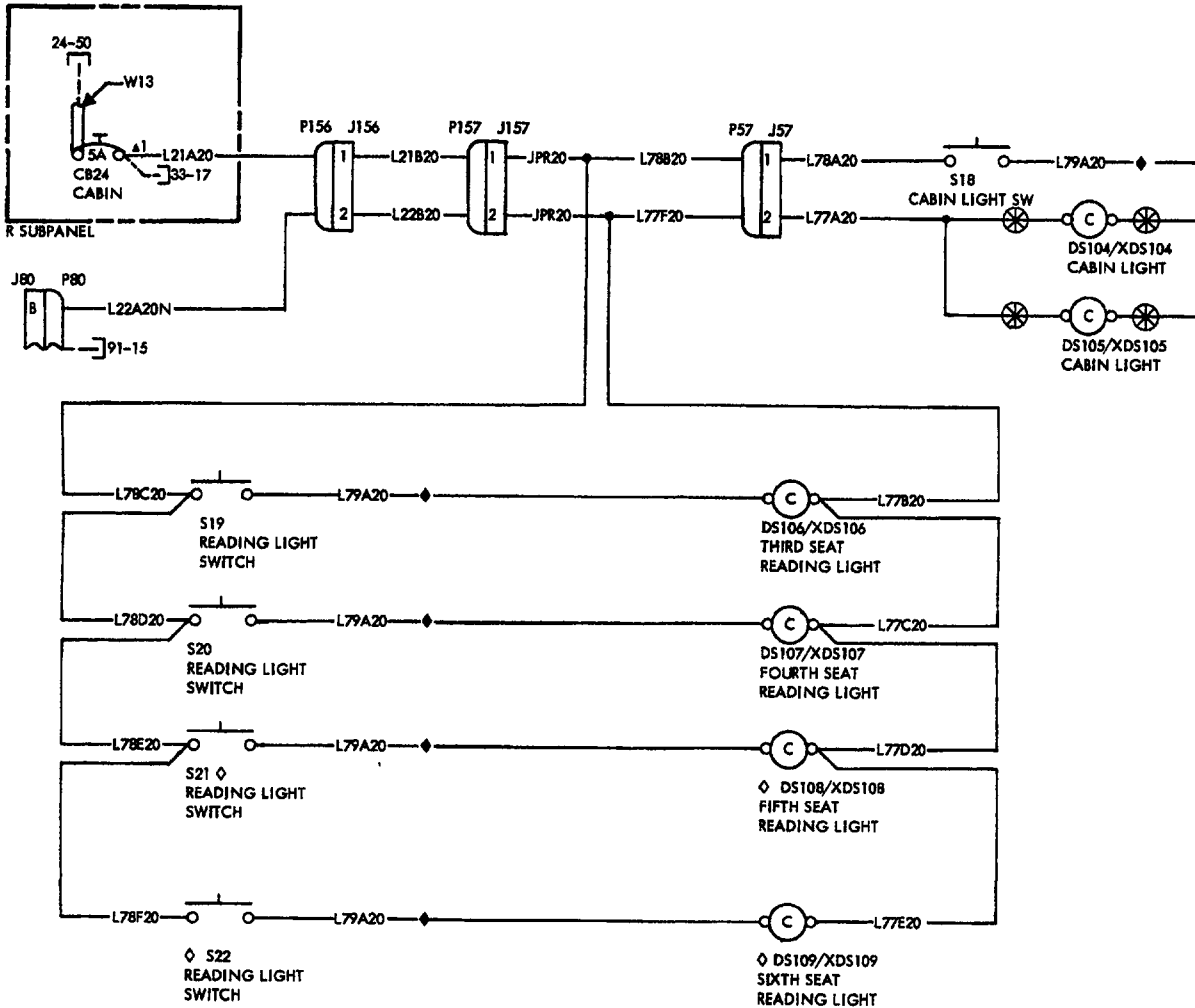

◇ OPTIONAL EQUIPMENT.
◆ WIRE NUMBER
DUPLICATED FOR
INTERCHANGEABILITY.

LIGHTS-CABIN

Beechcraft BONANZA WIRING DIAGRAM MANUAL

REFERENCE DESIGNATOR	PART NUMBER	DESCRIPTION	USABLE INSTL ON ZONE CODE
33-20-02			
CB24	7277-2-5	CIRCUIT BREAKER-CABIN AND MAP LIGHT	240 1
DS104	1864	BULB-CABIN LIGHT	253 1
DS105	1864	BULB-CABIN LIGHT	253 1
DS106	303	BULB-READING LIGHT, THIRD SEAT	253 1
DS107	303	BULB-READING LIGHT, FOURTH SEAT	253 1
DS108	303	BULB-READING LIGHT, FIFTH SEAT (OPTL)	253 1
DS109	303	BULB-READING LIGHT, SIXTH SEAT (OPTL)	253 1
J156A	1-480319-0	RECEPTACLE-COLUMN HEADLINER LIGHT	251 1
J156B	60618-1	PIN CONTACT	251 1
J157A	1-480319-0	RECEPTACLE-HEADLINER LIGHTING	253 1
J157B	60619-1	PIN CONTACT	253 1
J57A	1-480319-0	RECEPTACLE-CABIN LIGHTS	253 1
J57B	60618-1	PIN CONTACT	253 1
J80	204814-1	RECEPTACLE-GROUNDING BLOCK	231 1
P156A	1-480318-0	PLUG-COLUMN HEADLINER LIGHT	251 1
P156B	60617-1	SOCKET CONTACT	251 1
P157A	1-480318-0	PLUG-HEADLINER LIGHTING	253 1
P157B	60617-1	SOCKET CONTACT	253 1
P57A	1-480318-0	PLUG-CABIN LIGHTS	253 1
P57B	60617-1	SOCKET CONTACT	253 1
P80A	200838-3	PLUG-GROUNDING BLOCK	231 1
P80B	201224-1	STRAIN RELIEF	231 1
P80C	201328-1	SOCKET CONTACT	231 1
P80D	200333-1	SOCKET CONTACT	231 1
P80E	203618-1	JACKSCREW	231 1
S18	L18366-3	SWITCH-CABIN LIGHT	253 1
S19	L18366-3	SWITCH-THIRD SEAT READING LIGHT	253 1
S20	L18366-3	SWITCH-FOURTH SEAT READING LIGHT	253 1
S21	L18366-3	SWITCH-FIFTH SEAT READING LIGHT (OPTL)	253 1
S22	L18366-3	SWITCH-SIXTH SEAT READING LIGHT (OPTL)	253 1
W13	114931-1-12	BUS-MAIN	240 1
XDS104	2506	LAMPHOLDER-CABIN LIGHT	253 1
XDS105	2506	LAMPHOLDER-CABIN LIGHT	253 1
XDS106	2565	LAMPHOLDER-THIRD READING LIGHT	253 1
XDS107	2565	LAMPHOLDER-FOURTH READING LIGHT	253 1
XDS108	2565	LAMPHOLDER-FIFTH SEAT READING LIGHT (OPTL)	253 1
XDS109	2565	LAMPHOLDER-SIXTH SEAT READING LIGHT (OPTL)	253 1

EFFECTIVITY CODE

1. E-1422, E-1551, E-1569, E-1594 THRU E-1945, E-1947 THRU E-2103, E-2105 THRU E-2110;
CE-919, CE-923, CE-925, CE-927, CE-929 AND AFTER; CJ-156 AND AFTER; D-10348, D-10353 AND
AFTER; EA-33 THRU EA-319, EA-321 THRU EA-388

Beechcraft
BONANZA
WIRING DIAGRAM MANUAL

33-40-01

**E-1111, E-1241 THRU E-1470; CE-748, CE-772 THRU CE-850; CJ-149
ONLY; D-10097, D-10120 THRU D-10241; EA-1 THRU EA-3**

Beechcraft BONANZA WIRING DIAGRAM MANUAL

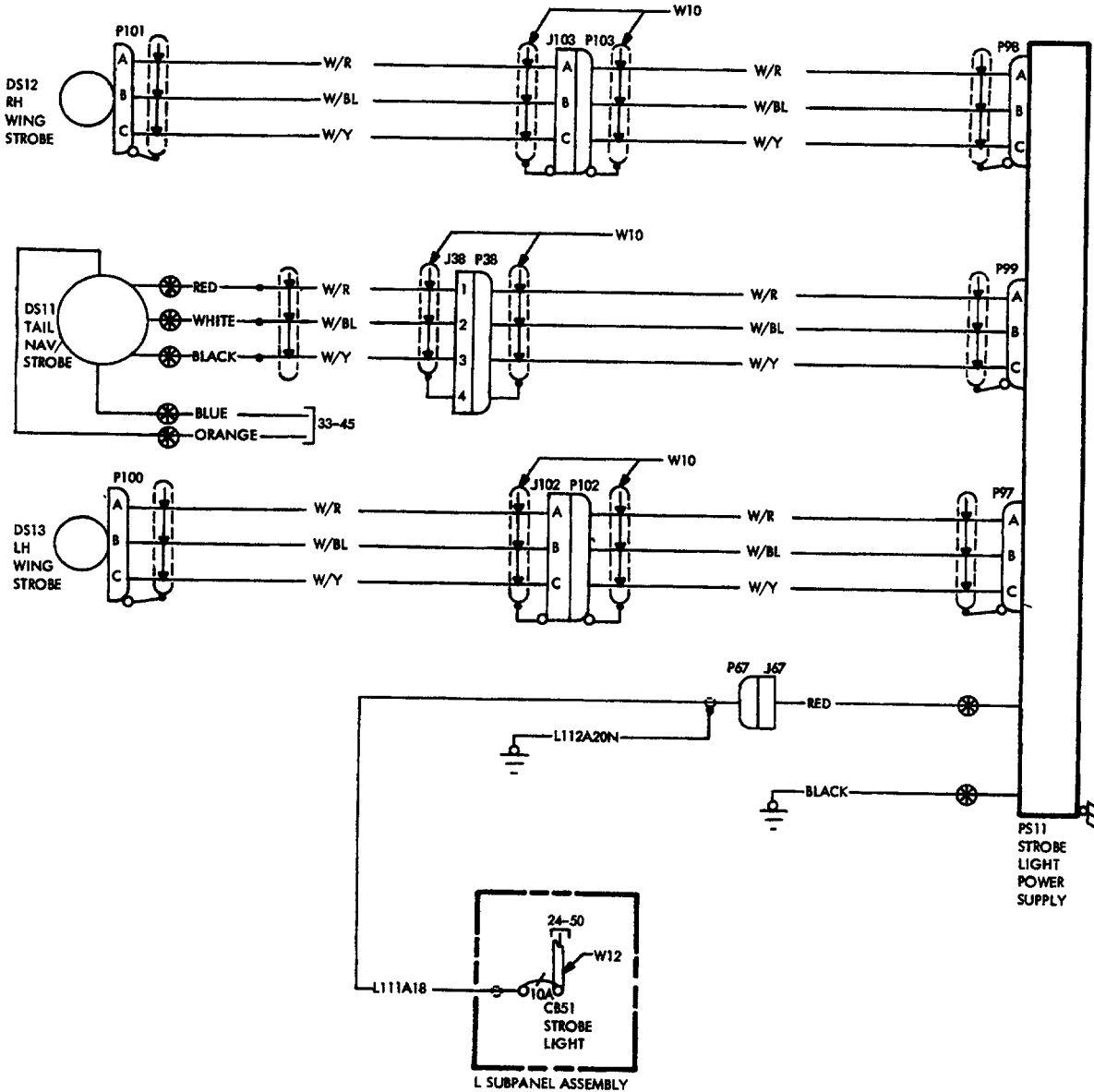

LIGHTS-THREE LIGHT STROBE (OPTIONAL)

Beechcraft BONANZA WIRING DIAGRAM MANUAL

REFERENCE DESIGNATOR	PART NUMBER	DESCRIPTION	INSTL	ON ZONE CODE	USABLE
33-40-01					
CB51	35-380132-43	CIRCUIT BREAKER-STROBE LIGHT	240		1
DS11A	30-0815-5	LIGHT-TAIL NAVIGATION/STROBE (OPTL)	370		3
DS11A	30-0815-1	LIGHT-TAIL NAVIGATION/STROBE (OPTL)	370		2
DS11B	31-2440-3	LIGHT SUBASSEMBLY (OPTL)	370		2
DS11C	678	LAMP-NAVIGATION (OPTL)	370		2
DS12A1	30-1331-3	LIGHT-RIGHT WING STROBE (OPTL) (ALTN FOR 701148-7-2)	650		1
DS12A2	701148-7-2	LIGHT-RIGHT WING STROBE (OPTL) (ALTN FOR 30-1331-3)	650		1
DS12B1	25-0491-1	COVER (OPTL)	650		1
DS12B2	202065	LENS/GLASS (OPTL)	650		1
DS12C1	31-3792-7	LIGHT SUBASSEMBLY (OPTL)	650		1
DS12C2	2023382	RETAINER ASSEMBLY-LAMP (OPTL)	650		1
DS12D1	55-0221	LIGHT SUBASSEMBLY (OPTL)	650		1
DS12D2	202331	FLASHTUBE (OPTL)	650		1
DS12E2	202323	TRIGGER TRANSFORMER (OPTL)	650		1
DS12F2	202055	INSULATOR-TRIGGER CONTACT (OPTL)	650		1
DS12G2	MS3102A10SL3P	RECEPTACLE (OPTL)	650		1
DS13	30-1331-3	LIGHT-LEFT WING STROBE (OPTL) (ALTN FOR 701148-7-2) (REFER TO DS12 FOR BREAKDOWN)	550		1
DS13	701148-7-2	LIGHT-LEFT WING STROBE (OPTL) (ALTN FOR 30-1331-3) (REFER TO DS12 FOR BREAKDOWN)	550		1
J102	MS3101E10SL3P	RECEPTACLE-STROBE WING BREAK, LEFT (OPTL) (ALTN FOR CA3101E10SL3P-F80)	532		1
J102	CA3101E10SL3P-F80	RECEPTACLE-LH STROBE WING BREAK (OPTL)	532		1
J103	MS3101E10SL3P	RECEPTACLE-STROBE WING BREAK, RIGHT (OPTL) (ALTN FOR CA3101E10SL3P-F80)	632		1
J38A	1-480703-0	RECEPTACLE-TAIL STROBE (OPTL)	310		1
J38B	350547-1	PIN CONTACT	310		1
J67A	1-480351-0	RECEPTACLE-STROBE POWER SUPPLY (OPTL)	310		1
J67B	60618-1	PIN CONTACT	310		1
PS11	01-0790079-04	POWER SUPPLY-STROBE (OPTL)	310		1
PS11	701571	POWER SUPPLY-STROBE (OPTL) (ALTN FOR 60-1750-3)	310		1
PS11	60-1750-3	POWER SUPPLY-STROBE (OPTL)	310		1
P100	CA3106E10SL3S-F80	PLUG-LEFT WING STROBE (OPTL)	550		1
P101	CA3106E10SL3S-F80	PLUG-RIGHT WING STROBE (OPTL)	650		1
P102	CA3106E10SL3S-F80	PLUG-LEFT STROBE WING BREAK (OPTL)	550		1
P103	CA3106E10SL3S-F80	PLUG-RIGHT STROBE WING BREAK (OPTL)	650		1
P38A	CA3106E10SL-3S-F80	PLUG-TAIL STROBE (OPTL) (ALTN FOR MS3106E10SL-3S OR 1-480702-1)	310		1
P38A	MS3106E10SL-3S	PLUG-TAIL STROBE (OPTL) (ALTN FOR CA3106E10SL-3S-F80 OR 1-480702-1)	310		1
P38A	1-480702-1	PLUG-TAIL STROBE (OPTL)	310		1
P38B	350550-1	SOCKET CONTACT	310		1
P67A	1-480349-0	PLUG-STROBE POWER SUPPLY (OPTL)	310		1
P67B	60617-1	SOCKET CONTACT	310		1
P97	CA3106E10SL3S-F80	PLUG-LEFT WING STROBE POWER SUPPLY (OPTL)	310		1
P97	MS3106E10SL-3S	PLUG-WING STROBE POWER SUPPLY, LEFT (OPTL) (ALTN FOR CA3106E10SL3S-F80)	310		1
P97	CA3106E10SL3S-F80	PLUG-WING STROBE POWER SUPPLY, LEFT (OPTL) (ALTN FOR MS3106E10SL-3S)	310		1
P98	CA3106E10SL3S-F80	PLUG-RIGHT WING STROBE POWER SUPPLY (OPTL)	310		1

Beechcraft BONANZA WIRING DIAGRAM MANUAL

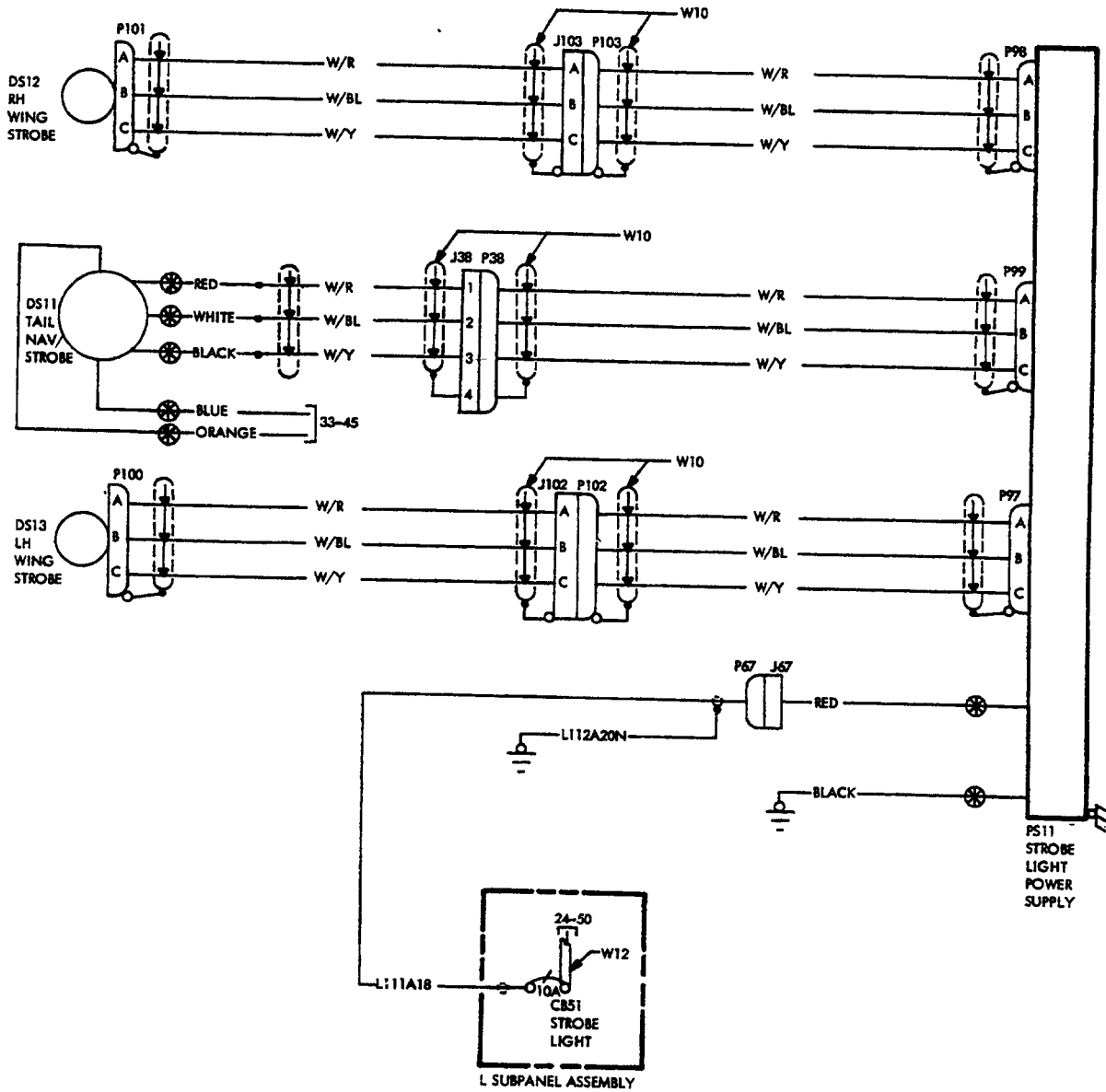

LIGHTS-THREE LIGHT STROBE (OPTIONAL)

Beechcraft
BONANZA
WIRING DIAGRAM MANUAL

REFERENCE DESIGNATOR	PART NUMBER	DESCRIPTION	USABLE	
			INSTL	ON ZONE CODE
33-40-01				
P98	MS3106E10SL-3S	PLUG-WING STROBE POWER SUPPLY, RIGHT (OPTL) (ALTN FOR CA3106E10SL3S-F80)	310	1
P99	MS3106E10SL-3S	PLUG-TAIL STROBE POWER SUPPLY (OPTL) (ALTN FOR CA3106E10SL3S-F80)	310	1
P99	CA3106E10SL3S-F80	PLUG-TAIL STROBE POWER SUPPLY (OPTL) (ALTN FOR MS3106E10SL-3S)	310	1
W10	M7078/3-16-3	CABLE STROBE	310	1
W12	114931-1-6	BUS LIGHT	240	1

EFFECTIVITY CODE

1. E-1111, E-1241 THRU E-1470; CE-748, CE-772 THRU CE-850; CJ-149 ONLY; D-10097, D-10120 THRU D-10241; EA-1 THRU EA-3
2. E-1111, E-1241 THRU E-1470; CE-748, CE-772 THRU CE-850; CJ-149 ONLY; D-10097, D-10120 THRU D-10241
3. EA-1 THRU EA-3

Beechcraft
BONANZA
WIRING DIAGRAM MANUAL

33-40-02

Configuration 1

**E-1471 THRU E-1945, E-1947 THRU E-2103, E-2105 THRU E-2110;
CE-851 THRU CE-1164; CJ-150 THRU CJ-179; D-10242 AND AFTER;
EA-4 THRU EA-319, EA-321 THRU EA-388**

Beechcraft BONANZA WIRING DIAGRAM MANUAL

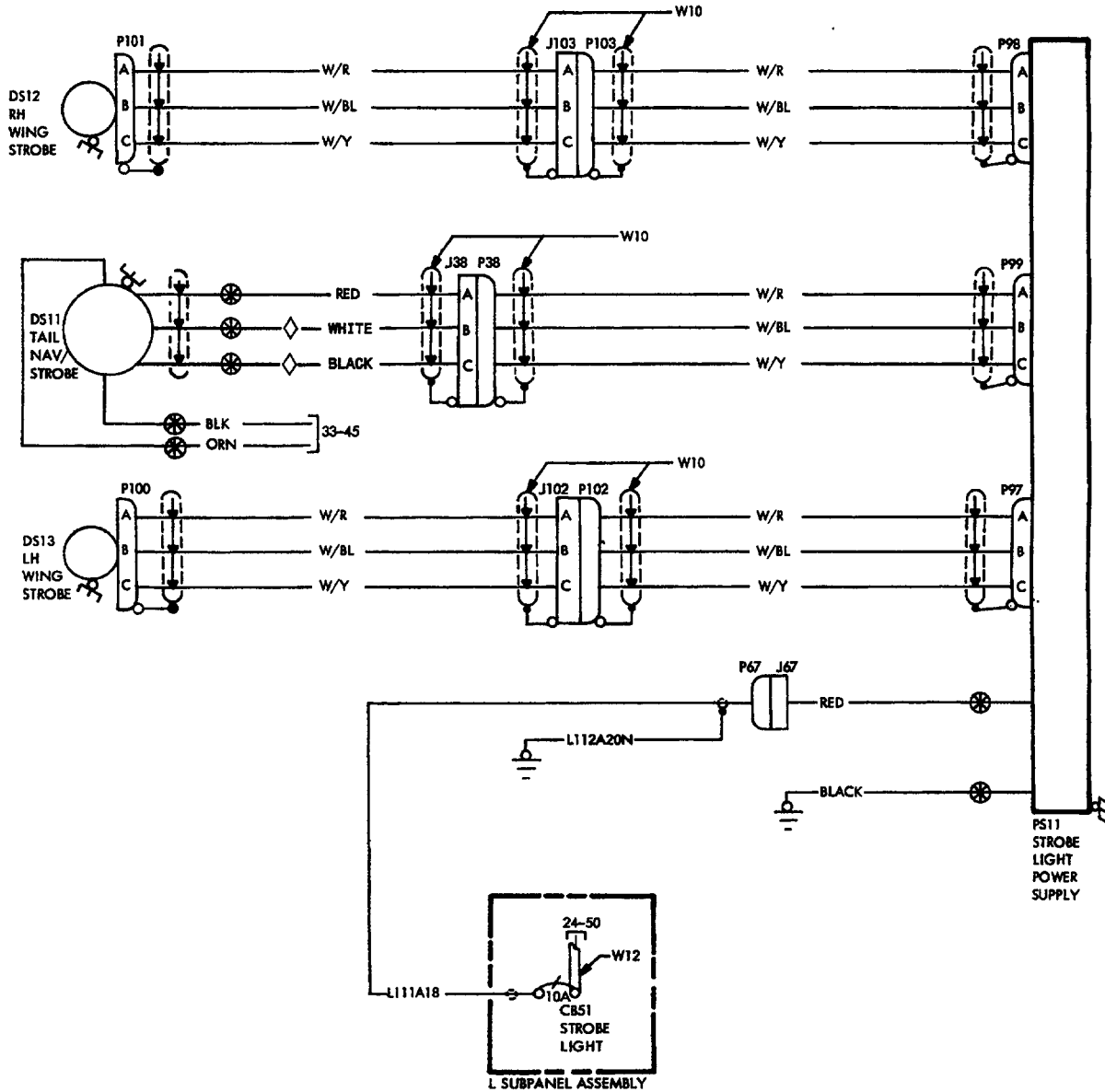

◇ ON ACFT PRIOR TO CE-987 & CJ-156, WHITE WIRE IS BLUE, AND BLACK WIRE IS YELLOW

LIGHTS-THREE LIGHT STROBE (OPTIONAL)
(Configuration 1)

Beechcraft
BONANZA
WIRING DIAGRAM MANUAL

REFERENCE DESIGNATOR	PART NUMBER	DESCRIPTION	USABLE INSTL ON ZONE CODE	
33-40-02				
(Configuration 1)				
CB51	35-380132-43	CIRCUIT BREAKER-STROBE LIGHT	240	1
DS11A	30-0815-5	LIGHT ASSEMBLY-TAIL NAVIGATION/STROBE (OPTL)	370	2
DS11A	A500A-B28	LIGHT ASSEMBLY-TAIL NAVIGATION/STROBE (ALTN FOR 30-0516-13)(SUPERSEDES A500B28)	370	3
DS11A	30-0516-13	LIGHT ASSEMBLY-TAIL NAVIGATION/STROBE (ALTN FOR A500A-B28)	370	3
DS11B	31-2440-5	LIGHT SUBASSEMBLY (OPTL) (A COMPONENT PART OF 30-0815-5)	370	2
DS11B	A506	FLASHTUBE AND SOCKET ASSEMBLY (A COMPONENT PART OF A500B28)	370	3
DS11B	31-1780-1	GASKET (A COMPONENT PART OF 30-0516-13)	370	3
DS11C	678	LAMP-NAVIGATION (OPTL) (A COMPONENT PART OF 30-0815-5)	370	2
DS11C	A510	LAMP ASSEMBLY (NAV) (A COMPONENT PART OF A500B28)	370	3
DS11C	31-1740-9	LIGHT SUBASSEMBLY (A COMPONENT PART OF 30-0516-13)	370	3
DS11D	A508	LAMP-HALOGEN (A COMPONENT PART OF A500B28)	370	3
DS11D	31-1745	FLASHTUBE (STROBE) (A COMPONENT PART OF 30-0516-13)	370	3
DS11E	A457A	LENS (A COMPONENT PART OF A500B28)	370	3
DS11E	678	LAMP (NAV) (A COMPONENT PART OF 30-0516-13)	370	3
DS11F	A457A-0	LENS ASSEMBLY-RADIO SHIELDED (OPTL) (A COMPONENT PART OF A500B28)	370	3
DS12A	30-1331-3	LIGHT-RIGHT WING STROBE (OPTL) (ALTN FOR 701148-7-2)	650	1
DS12A	701148-7-2	LIGHT-RIGHT WING STROBE (OPTL) (ALTN FOR 30-1331-3)	650	1
DS12B	25-0491-1	COVER (OPTL) (A COMPONENT PART OF 30-1331-3)	650	1
DS12B	202065	LENS-GLASS (OPTL) (A COMPONENT PART OF 701148-7-2)	650	1
DS12C	31-3792-7	LIGHT SUBASSEMBLY (OPTL) (A COMPONENT PART OF 30-1331-3)	650	1
DS12C	203382	RETAINER ASSEMBLY-LAMP (OPTL) (A COMPONENT PART OF 701148-7-2)	650	1
DS12D	55-0221-1	LIGHT SUBASSEMBLY (OPTL) (A COMPONENT PART OF 30-1331-3)	650	1
DS12D	202331	FLASHTUBE (OPTL) (A COMPONENT PART OF 701148-7-2)	650	1
DS12E	30-1467-101	RECEPTACLE (A COMPONENT PART OF 30-1331-3)	650	1
DS12E	202323	TRIGGER TRANSFORMER (OPTL) (A COMPONENT PART OF 701148-7-2)	650	1
DS12F	202055	INSULATOR-TRIGGER CONTACT (OPTL) (A COMPONENT PART OF 701148-7-2)	650	1
DS12G	MS3102A10SL3P	RECEPTACLE (OPTL) (A COMPONENT PART OF 701148-7-2)	650	1
DS13	30-1331-3	LIGHT-LEFT WING STROBE (OPTL) (ALTN FOR 701148-7-2) (REFER TO DS12 FOR BREAKDOWN)	550	1
DS13	701148-7-2	LIGHT-LEFT WING STROBE (OPTL) (ALTN FOR 30-1331-3) (REFER TO DS12 FOR BREAKDOWN)	550	1
J102	CA3106E10SL3P-F80	RECEPTACLE-STROBE WING BREAK, RIGHT (OPTL) (ALTN FOR MS3106E10SL3P)	532	1
J103	CA3101E10SL3P-F80	RECEPTACLE-STROBE WING BREAK, RIGHT (OPTL) (ALTN FOR MS3101E10SL3P)	632	1
J38A	1-480703-0	RECEPTACLE-TAIL STROBE (OPTL)	310	4
J38B	350547-1	PIN CONTACT	310	4
J67A	1-480351-0	RECEPTACLE-STROBE POWER SUPPLY (OPTL)	310	1
J67B	60618-1	PIN CONTACT	310	1
PS11	01-0790079-04	POWER SUPPLY-STROBE (OPTL)	310	1

Beechcraft BONANZA WIRING DIAGRAM MANUAL

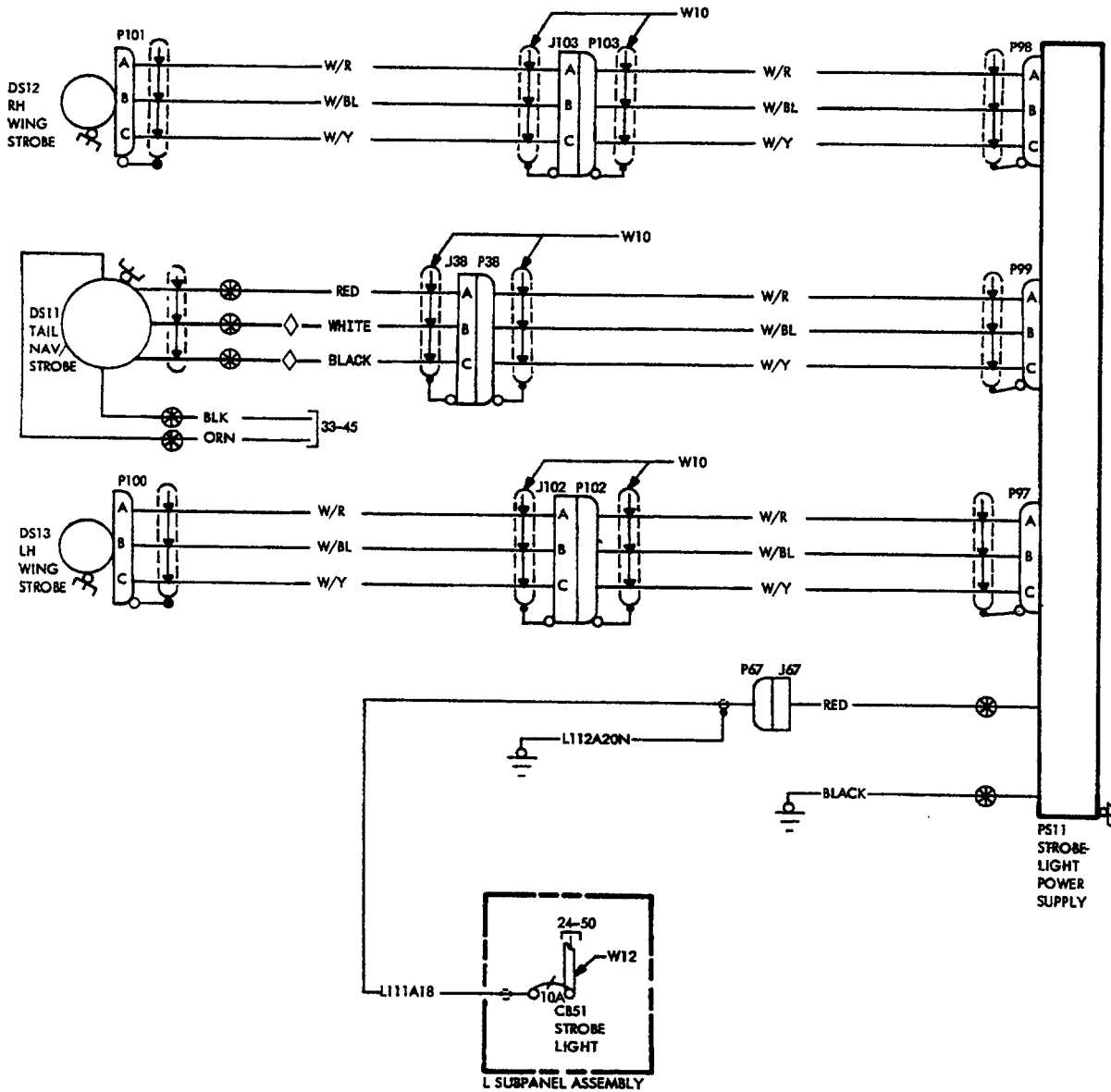

◇ ON ACFT PRIOR TO CE-987 & CJ-156, WHITE WIRE IS BLUE, AND BLACK WIRE IS YELLOW

LIGHTS-THREE LIGHT STROBE (OPTIONAL)
(Configuration 1)

Beechcraft
BONANZA
WIRING DIAGRAM MANUAL

REFERENCE DESIGNATOR	PART NUMBER	DESCRIPTION	USABLE	
			INSTL ZONE	ON CODE
33-40-02 (Configuration 1)				
PS11	701571	POWER SUPPLY-STROBE (OPTL) (ALTN FOR 60-1750-3)	310	1
PS11	60-1750-3	POWER SUPPLY-STROBE (OPTL) (ALTN FOR 701571)	310	1
P100	CA3106E10SL3S-F80	PLUG-LEFT WING STROBE (OPTL) (ALTN FOR MS3106E10SL-3S)	550	1
P101	CA3106E10SL3S-F80	PLUG-RIGHT WING STROBE (OPTL) (ALTN FOR MS3106E10SL-3S)	650	1
P102	CA3106E10SL3S-F80	PLUG-LEFT STROBE WING BREAK (OPTL) (MS3106E10SL-3S)	550	1
P103	CA3106E10SL3S-F80	PLUG-RIGHT STROBE WING BREAK (OPTL) (ALTN FOR MS3106E10SL-3S)	650	1
P38A	CA3106E10SL3S-F80	PLUG-TAIL STROBE (OPTL) (ALTN FOR MS3106E10SL-3S OR 1-480702-1)	310	1
P38A	MS3106E10SL-3S	PLUG-TAIL STROBE (OPTL) (ALTN FOR CA3106E10SL3S-F80 OR 1-480702-1)	310	1
P38A	1-480702-1	PLUG-TAIL STROBE (OPTL)	310	1
P38B	350550-1	SOCKET CONTACT	310	1
P67A	1-480349-0	PLUG-STROBE POWER SUPPLY (OPTL)	310	1
P67B	60617-1	SOCKET CONTACT	310	1
P97	MS3106E10SL-3S	PLUG-WING STROBE POWER SUPPLY, LEFT (OPTL)	310	1
P97	CA3106E10SL3S-F80	PLUG-WING STROBE POWER SUPPLY, LEFT (OPTL) (ALTN FOR MS3106E10SL-3S)	310	1
P98	CA3106E10SL3S-F80	PLUG-WING STROBE POWER SUPPLY (OPTL) (ALTN FOR MS3106E10SL-3S)	310	1
P98	MS3106E10SL-3S	PLUG-WING STROBE POWER SUPPLY, RIGHT (OPTL)	310	1
P99	MS3106E10SL-3S	PLUG-TAIL STROBE POWER SUPPLY (OPTL)	310	1
P99	CA3106E10SL3S-F80	PLUG-TAIL STROBE POWER SUPPLY (OPTL) (ALTN FOR MS3106E10SL3S)	310	1
W10	M7078/3-16-3	CABLE STROBE	310	1
W12	114931-1-6	BUS LIGHT	240	1

EFFECTIVITY CODE

1. E-1471 THRU E-1945, E-1947 THRU E-2103, E-2105 THRU E-2110; CE-851 THRU CE-1164; CJ-150 THRU CJ-179; D-10242 AND AFTER; EA-4 THRU EA-319, EA-321 THRU EA-388
2. E-1471 THRU E-1971; CE-851 THRU CE-985; CJ-150 THRU CJ-155; D-10242 THRU D-10509; EA-4 THRU EA-319, EA-321 THRU EA-388
3. E-1972 THRU E-2103, E-2105 THRU E-2110; CE-986 THRU CE-1164; CJ-156 THRU CE-179; D-10510 AND AFTER
4. E-1471 THRU E-1945, E-1947 THRU E-2103, E-2105 THRU E-2110; CE-851 THRU CE-1164; CJ-150 THRU CJ-179; D-10242 AND AFTER; EA-52 THRU EA-319, EA-321 THRU EA-388

Beechcraft
BONANZA
WIRING DIAGRAM MANUAL

33-40-02

Configuration 2

CE-1165 AND AFTER; CJ-180 AND AFTER

Beechcraft BONANZA WIRING DIAGRAM MANUAL

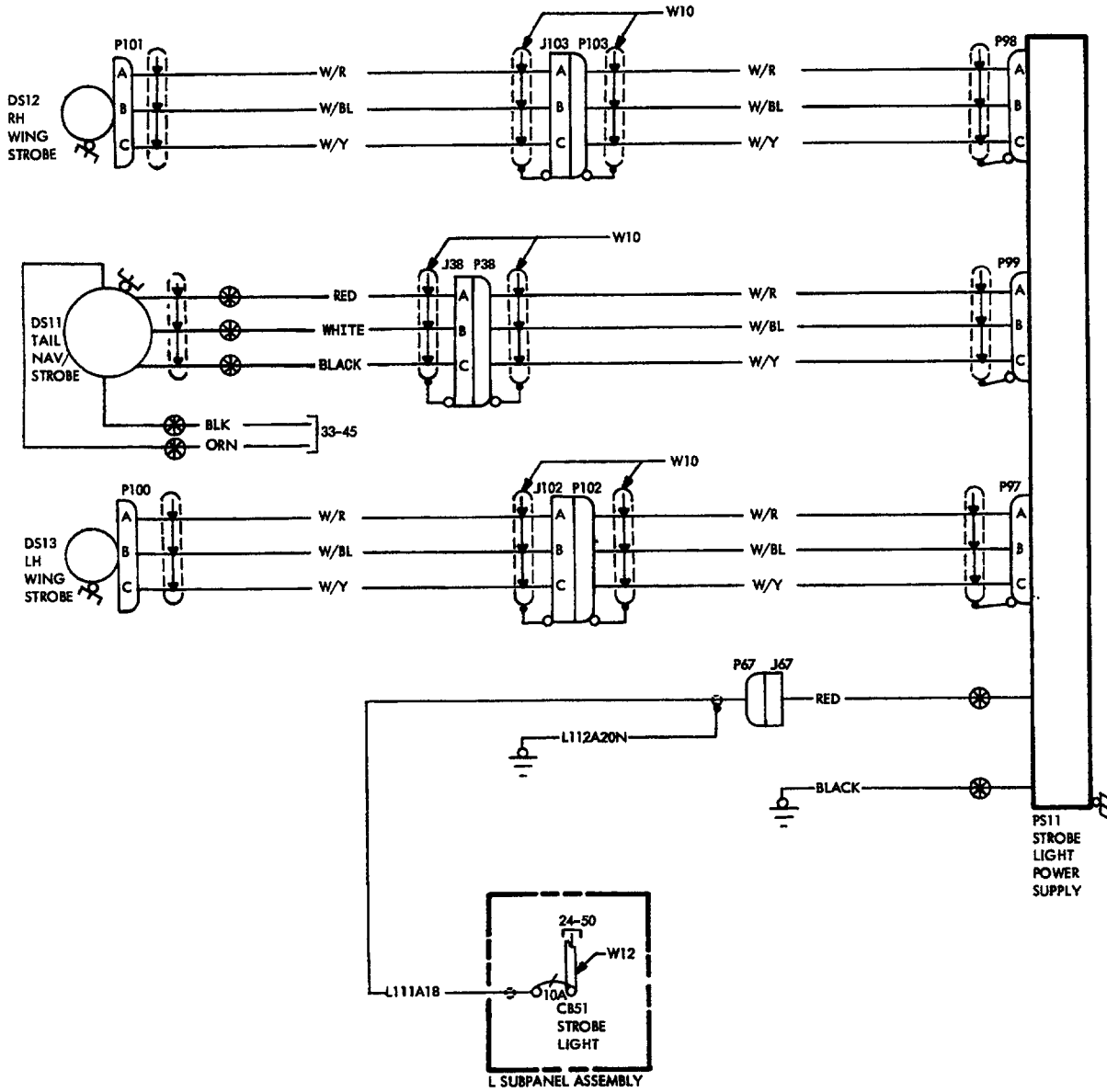

**LIGHTS-THREE LIGHT STROBE (OPTIONAL)
(Configuration 2)**

Beechcraft
BONANZA
WIRING DIAGRAM MANUAL

REFERENCE DESIGNATOR	PART NUMBER	DESCRIPTION	USABLE	
			INSTL	ON ZONE CODE
33-40-02 (Configuration 2)				
CB51	35-380132-43	CIRCUIT BREAKER-STROBE LIGHT	240	1
DS11A	A500A-B28	LIGHT ASSEMBLY-TAIL NAVIGATION/STROBE (ALTN FOR 30-0516-13)(SUPERSEDES A500B28)	370	1
DS11A	30-0516-13	LIGHT ASSEMBLY-TAIL NAVIGATION/STROBE (ALTN FOR A500A-B28)	370	1
DS11B	A506	FLASHTUBE AND SOCKET ASSEMBLY (A COMPONENT PART OF A500B28)	370	1
DS11B	31-1780-1	GASKET (A COMPONENT PART OF 30-0516-13)	370	1
DS11C	A510	LAMP ASSEMBLY (NAV) (A COMPONENT PART OF A500B28)	370	1
DS11C	31-1740-9	LIGHT SUBASSEMBLY (A COMPONENT PART OF 30-0516-13)	370	1
DS11D	A508	LAMP-HALOGEN (A COMPONENT PART OF A500B28)	370	1
DS11D	31-1745	FLASHTUBE (STROBE) (A COMPONENT PART OF 30-0516-13)	370	1
DS11E	A457A	LENS (A COMPONENT PART OF A500B28)	370	1
DS11E	678	LAMP (NAV) (A COMPONENT PART OF 30-0516-13)	370	1
DS11F	A457A-0	LENS ASSEMBLY-RADIO SHIELDED (OPTL) (A COMPONENT PART OF A500B28)	370	1
DS12A	30-1331-3	LIGHT-RIGHT WING STROBE (OPTL) (ALTN FOR 701148-7-2)	650	1
DS12A	701148-7-2	LIGHT-RIGHT WING STROBE (OPTL) (ALTN FOR 30-1331-3)	650	1
DS12B	25-0491-1	COVER (OPTL) (A COMPONENT PART OF 30-1331-3)	650	1
DS12B	202065	LENS-GLASS (OPTL) (A COMPONENT PART OF 701148-7-2)	650	1
DS12C	31-3792-7	LIGHT SUBASSEMBLY (OPTL) (A COMPONENT PART OF 30-1331-3)	650	1
DS12C	203382	RETAINER ASSEMBLY-LAMP (OPTL) (A COMPONENT PART OF 30-1331-3)	650	1
DS12D	55-0221-1	LIGHT SUBASSEMBLY (OPTL) (A COMPONENT PART OF 30-1331-3)	650	1
DS12D	202331	FLASHTUBE (OPTL) (A COMPONENT PART OF 701148-7-2)	650	1
DS12E	30-1467-101	RECEPTACLE (A COMPONENT PART OF 30-1331-3)	650	1
DS12E	202323	TRIGGER TRANSFORMER (OPTL) (A COMPONENT PART OF 701148-7-2)	650	1
DS12F	202055	INSULATOR-TRIGGER CONTACT (OPTL) (A COMPONENT PART OF 701148-7-2)	650	1
DS12G	MS3102A10SL3P	RECEPTACLE (OPTL) (A COMPONENT PART OF 701148-7-2)	650	1
DS13	30-1331-3	LIGHT-LEFT WING STROBE (OPTL) (ALTN FOR 701148-7-2) (REFER TO DS12 FOR BREAKDOWN)	550	1
DS13	701148-7-2	LIGHT-LEFT WING STROBE (OPTL) (ALTN FOR 30-1331-3) (REFER TO DS12 FOR BREAKDOWN)	550	1
J102	CA3106E10SL3P-F80	RECEPTACLE-STROBE WING BREAK, RIGHT (OPTL) (ALTN FOR MS3106E10SL3P)	532	1
J103	CA3101E10SL3P-F80	RECEPTACLE-STROBE WING BREAK, RIGHT (OPTL) (ALTN FOR MS3101E10SL3P)	632	1
J38A	1-480703-0	RECEPTACLE-TAIL STROBE (OPTL)	310	1
J38B	350547-1	PIN CONTACT	310	1
J67A	1-480351-0	RECEPTACLE-STROBE POWER SUPPLY (OPTL)	310	1
J67B	60618-1	PIN CONTACT	310	1
PS11	01-0790079-04	POWER SUPPLY-STROBE (OPTL)	310	1
PS11	701571	POWER SUPPLY-STROBE (OPTL) (ALTN FOR 60-1750-3)	310	1
PS11	60-1750-3	POWER SUPPLY-STROBE (OPTL) (ALTN FOR 701571)	310	1
P100	CA3106E10SL3S-F80	PLUG-LEFT WING STROBE (OPTL) (ALTN FOR MS3106E10SL-3S)	550	1
P101	CA3106E10SL3S-F80	PLUG-RIGHT WING STROBE (OPTL) (ALTN FOR MS3106E10SL-3S)	650	1

Beechcraft BONANZA WIRING DIAGRAM MANUAL

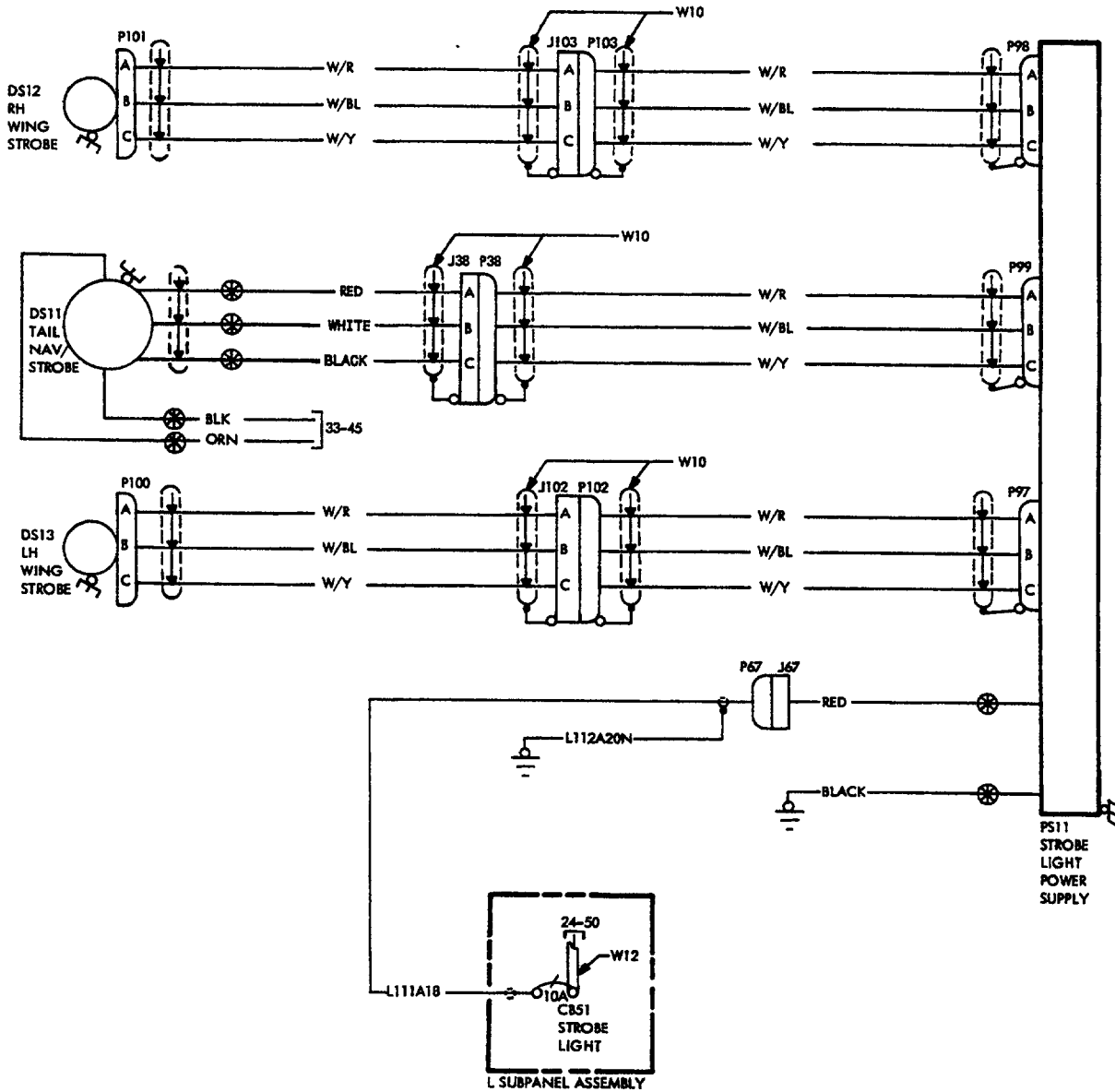

**LIGHTS-THREE LIGHT STROBE (OPTIONAL)
(Configuration 2)**

Beechcraft
BONANZA
WIRING DIAGRAM MANUAL

REFERENCE DESIGNATOR	PART NUMBER	DESCRIPTION	USABLE	
			INSTL ZONE	ON CODE
33-40-02 (Configuration 2)				
P102	CA3106E10SL3S-F80	PLUG-LEFT STROBE WING BREAK (OPTL) (ALTN FOR MS3106E10SL-3S)	550	1
P103	CA3106E10SL3S-F80	PLUG-RIGHT STROBE WING BREAK (OPTL) (ALTN FOR MS3106E10SL-3S)	650	1
P38A	CA3106E10SL3S-F80	PLUG-TAIL STROBE (OPTL) (ALTN FOR MS3106E10SL-3S OR 1-480702-1)	310	1
P38A	MS3106E10SL-3S	PLUG-TAIL STROBE (OPTL) (ALTN FOR CA3106E10SL3S-F80 OR 1-480702-1)	310	1
P38A	1-480702-1	PLUG-TAIL STROBE (OPTL)	310	1
P38B	350550-1	SOCKET CONTACT	310	1
P67A	1-480349-0	PLUG-STROBE POWER SUPPLY (OPTL)	310	1
P67B	60617-1	SOCKET CONTACT	310	1
P97	MS3106E10SL-3S	PLUG-WING STROBE POWER SUPPLY, LEFT (OPTL)	310	1
P97	CA3106E10SL3S-F80	PLUG-WING STROBE POWER SUPPLY, LEFT (OPTL) (ALTN FOR MS3106E10SL-3S)	310	1
P98	CA3106E10SL3S-F80	PLUG-WING STROBE POWER SUPPLY (OPTL) (ALTN FOR MS3106E10SL-3S)	310	1
P98	MS3106E10SL-3S	PLUG-WING STROBE POWER SUPPLY, RIGHT (OPTL)	310	1
P99	MS3106E10SL-3S	PLUG-TAIL STROBE POWER SUPPLY (OPTL)	310	1
P99	CA3106E10SL3S-F80	PLUG-TAIL STROBE POWER SUPPLY (OPTL) (ALTN FOR MS3106E10SL3S)	310	1
W10	M7078/3-16-3	CABLE STROBE	310	1
W12	114931-1-6	BUS LIGHT	240	1

EFFECTIVITY CODE

1. CE-1165 AND AFTER; CJ-180 AND AFTER

Beechcraft
BONANZA
WIRING DIAGRAM MANUAL

33-42-01

**E-1111, E-1241 THRU E-1945, E-1947 THRU E-2103, E-2105 THRU
E-2110; CE-748, CE-772 AND AFTER; D-10097, D-10120 AND AFTER;
EA-1 THRU EA-319, EA-321 THRU EA-388**

Beechcraft BONANZA WIRING DIAGRAM MANUAL

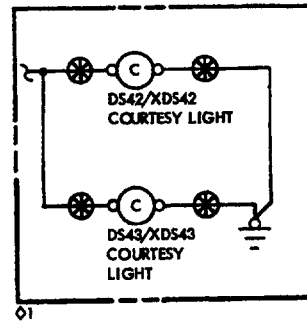
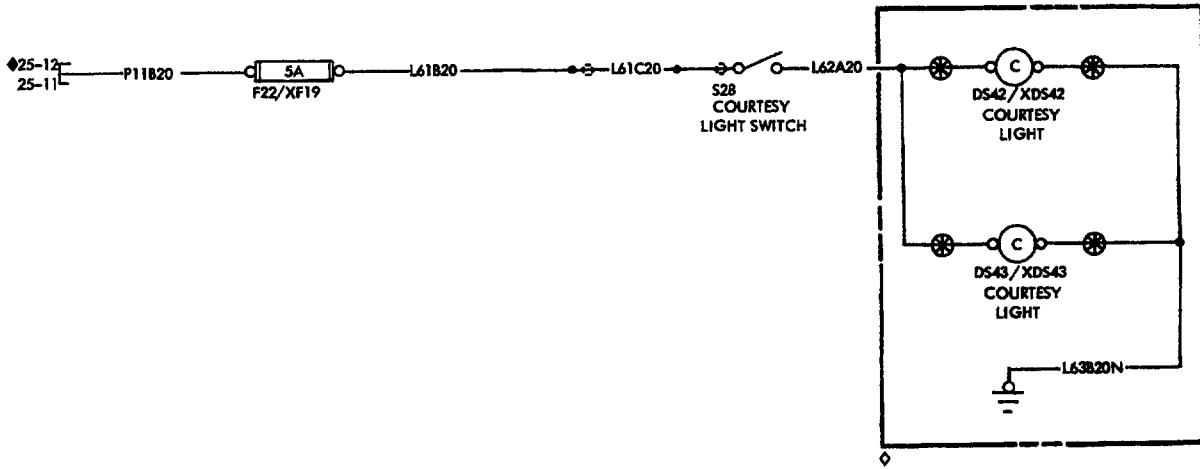

- ◇ WIRE AS SHOWN E-1620 & AFTER; EA-47 & AFTER;
CE-893 & AFTER; D-10320 & AFTER.
- ◇1 WIRE AS SHOWN E-1111, E-1241 THRU E-1619; EA-1 THRU EA-46;
CE-748, CE-772 THRU CE-892, D-10097, D-10120 THRU D-10319.
- ◆ WITH OPTIONAL
DIGITAL CONTROL
WHEEL CLOCK.

LIGHTS-COURTESY (OPTIONAL)

Beechcraft
BONANZA
WIRING DIAGRAM MANUAL

REFERENCE DESIGNATOR	PART NUMBER	DESCRIPTION	USABLE	
			INSTL ZONE	ON CODE
33-42-01				
DS42A	30-0502-5	LIGHT-COURTESY (OPTL)	820	1
DS42B	31-1705-3	LENS (OPTL)	820	1
DS42C	1864	BULB (OPTL)	820	1
DS43A	30-0502-5	LIGHT-COURTESY (OPTL)	820	1
DS43B	31-1705-3	LENS (OPTL)	820	1
DS43C	1864	BULB (OPTL)	820	1
F22	AGC-5	FUSE-COURTESY LIGHT (OPTL)	222	1
S28	8410K1	SWITCH-COURTESY LIGHT (OPTL) (ALTN FOR SW442 OR C5AZ13713A)	820	1
S28	SW442	SWITCH-COURTESY LIGHT (OPTL) (ALTN FOR 8410K1 OR C5AZ13713A)	820	1
S28	C5AZ13713A	SWITCH-COURTESY LIGHT (OPTL) (ALTN FOR 8410K1 OR SW442)	820	1
XDS42	2506	LAMPHOLDER-COURTESY LIGHT (OPTL)	820	1
XDS43	2506	LAMPHOLDER-COURTESY LIGHT (OPTL)	820	1
XF19	4532	FUSEHOLDER-CLUTCH AND CONDENSER, DOOR ACTUATOR (OPTL)	222	2

EFFECTIVITY CODE

1. E-1111, E-1241 THRU E-1945, E-1947 THRU E-2103, E-2105 THRU E-2110; CE-748, CE-772 AND AFTER; D-10097, D-10120 AND AFTER; EA-1 THRU EA-319, EA-321 THRU EA-388

2. E-1111, E-1241 THRU E-1945, E-1947 THRU E-2103, E-2105 THRU E-2110; CE-748, CE-772 AND AFTER; D-10097, D-10120 AND AFTER; EA-356 THRU EA-388

Beechcraft
BONANZA
WIRING DIAGRAM MANUAL

33-43-01

**E-1111, E-1241 THRU E-1945, E-1947 THRU E-2103, E-2105 THRU
E-2110; CE-748, CE-772 AND AFTER; CJ-149 AND AFTER; D-10097,
D-10120 AND AFTER; EA-1 THRU EA-319, EA-321 THRU EA-388**

Beechcraft BONANZA WIRING DIAGRAM MANUAL

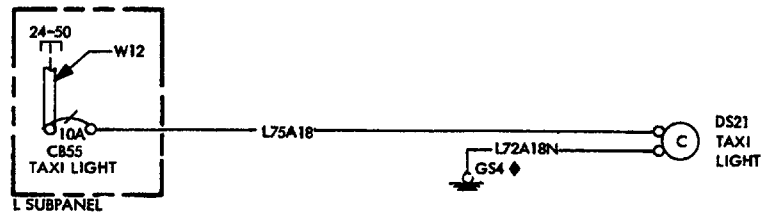

◆ ON AIRCRAFT E-1111, E-1241 THRU
E-1370, EA-1, CE-748, CE-772 THRU
CE-815, D-10097 & D-10120 THRU
D-10179, REF DES GS2 REPLACES
GS4.

LIGHTS-TAXI

Beechcraft
BONANZA
WIRING DIAGRAM MANUAL

REFERENCE DESIGNATOR	PART NUMBER	DESCRIPTION	USABLE	
			INSTL ZONE	ON CODE
33-43-01				
CB55	35-380132-43	CIRCUIT BREAKER-TAXI LIGHT	240	1
DS21	4596	LIGHT-TAXI	710	1
GS2A	131270-3	GROUND STUD-FIREWALL	221	2
GS2B	AN960-10	WASHER	221	2
GS2C	MS21045L3	BOLT	221	2
GS4A	AN3-5A	GROUND STUD-LOWER FIREWALL	222	3
GS4B	AN960-10L	WASHER	222	3
GS4C	MS21042L3	NUT	222	3
W12	114931-1-6	BUS LIGHT	240	1

EFFECTIVITY CODE

1. E-1111, E-1241 THRU E-1945, E-1947 THRU E-2103, E-2105 THRU E-2110; CE-748, CE-772 AND AFTER; CJ-149 AND AFTER; D-10097, D-10120 AND AFTER; EA-1 THRU EA-319, EA-321 THRU EA-388
2. E-1111, E-1241 THRU E-1370; CE-748, CE-772 THRU CE-815; D-10097, D-10120 THRU D-10178; EA-1 ONLY
3. E-1371 THRU E-1945, E-1947 THRU E-2103, E-2105 THRU E-2110; CE-816 AND AFTER; CJ-149 AND AFTER; D-10179 AND AFTER; EA-2 THRU EA-319, EA-321 THRU EA-388

Beechcraft
BONANZA
WIRING DIAGRAM MANUAL

33-44-01

**E-1111, E-1241 THRU E-1551; CE-748, CE-772 THRU CE-871; CJ-149
AND CJ-150; D-10097, D-10120 THRU D-10268; EA-1 THRU EA-11**

Beechcraft BONANZA WIRING DIAGRAM MANUAL

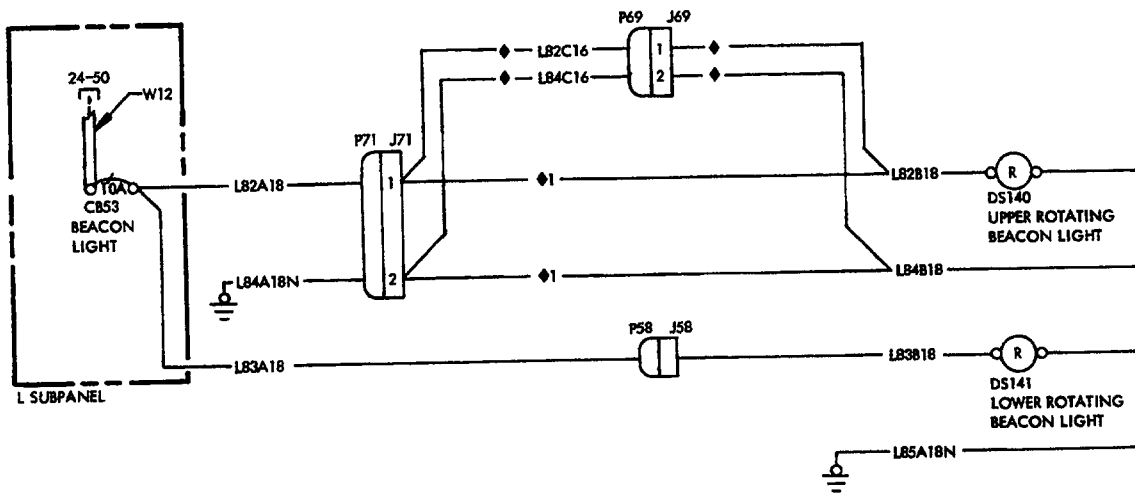

- ◆ ON AIRCRAFT E-1111, E-1241 THRU E-1551, & EA-1 THRU EA-11, WIRES L82C & L84C AND CONNECTORS P69 AND J69 ARE CONNECTED AS SHOWN.
- ◆ ON AIRCRAFT CE-748, CE-772 THRU CE-871, C.J-149 & C.J-150, D-10097, & D-10120 THRU D-10268, WIRES L82B & L84B ARE CONNECTED DIRECTLY TO J71.

LIGHTS-ROTATING BEACON (OPTIONAL)

Beechcraft
BONANZA
WIRING DIAGRAM MANUAL

REFERENCE DESIGNATOR	PART NUMBER	DESCRIPTION	USABLE	
			INSTL ZONE	ON CODE
33-44-01				
CB53	35-380132-43	CIRCUIT BREAKER-BEACON LIGHT	240	1
DS140A	36-364030-13	BEACON ASSEMBLY-VERTICAL STABILIZER	330	1
DS140A	36-364030-15	BEACON ASSEMBLY-UPPER FUSELAGE	253	2
DS140B	D7080A3-24	ROTATING LIGHT ASSEMBLY	330	1
DS140B	D7080A1-24	ROTATING LIGHT ASSEMBLY	253	2
DS140C	A7079B24	LAMP	330	1
DS140C	A7079B24	LAMP	253	2
DS140D	41-0190-1	MOTOR ASSEMBLY-BEACON	330	1
DS140D	A7942	LENS (RED)	253	2
DS140E	A7632	GASKET	253	2
DS140F	41-0190-1	MOTOR ASSEMBLY	253	2
DS141A	36-364030-11	BEACON ASSEMBLY-LOWER FUSELAGE (USED ON AIRPLANES WITH AIR CONDITIONING)	160	1
DS141A	36-364030-11	BEACON ASSEMBLY-LOWER FUSELAGE (USED ON AIRPLANES WITHOUT AIR CONDITIONING)	160	1
DS141B	D7080A5-24	ROTATING LIGHT ASSEMBLY (A COMPONENT PART OF 36-364030-11)	160	1
DS141C	A7079B24	LAMP (A COMPONENT PART OF 36-364030-11)	160	1
DS141D	A7942	LENS (A COMPONENT PART OF 36-364030-11) (USED ONLY ON AIRPLANES WITH AIR CONDITIONING)	160	1
DS141E	A7632	GASKET (A COMPONENT PART OF 36-364030-11) (USED ONLY ON AIRPLANES WITH AIR CONDITIONING)	160	1
DS141F	41-0190-3	MOTOR ASSEMBLY (A COMPONENT PART OF 36-364030-11)	160	1
J58A	1-480350-0	RECEPTACLE-LOWER ROTATING BEACON (OPTL)	160	1
J58B	60618-1	PIN CONTACT (OPTL)	160	1
J69A	1-480319-0	RECEPTACLE-UPPER ROTATING BEACON (OPTL)	330	3
J69B	60618-1	PIN CONTACT (OPTL)	330	3
J71A	1-480319-0	RECEPTACLE-UPPER ROTATING BEACON (OPTL)	310	1
J71B	60618-1	PIN CONTACT (OPTL)	310	1
P58A	1-480349-0	PLUG-LOWER ROTATING BEACON (OPTL)	160	1
P58A	1-480350-0	PLUG-LOWER ROTATING BEACON (OPTL)	160	3
P58B	60617-1	SOCKET CONTACT (OPTL)	160	2
P58B	60617-1	SOCKET CONTACT (OPTL)	160	3
P69A	1-480318-0	PLUG-UPPER BEACON EXTENTION (OPTL)	330	3
P69B	60617-1	SOCKET CONTACT (OPTL)	330	1
P71A	1-480318-0	PLUG-UPPER ROTATING BEACON (OPTL)	310	2
P71A	1-480350-0	PLUG-UPPER ROTATING BEACON (OPTL)	253	3
P71B	60617-1	SOCKET CONTACT (OPTL)	310	2
P71B	60617-1	SOCKET CONTACT (OPTL)	253	3
W12	114931-1-6	BUS LIGHT	240	1

EFFECTIVITY CODE

1. E-1111, E-1241 THRU E-1551; CE-748, CE-772 THRU CE-871; CJ-149 AND CJ-150; D-10097, D-10120 THRU D-10268; EA-1 THRU EA-11
2. CE-748, CE-772 THRU CE-871; CJ-149 AND CJ-150; D-10097, D-10120 THRU D-10268
3. E-1111, E-1241 THRU E-1551; EA-1 THRU EA-11

Beechcraft
BONANZA
WIRING DIAGRAM MANUAL

33-44-02

Configuration 1

CE-872 AND AFTER; CJ-151 AND AFTER

Beechcraft BONANZA WIRING DIAGRAM MANUAL

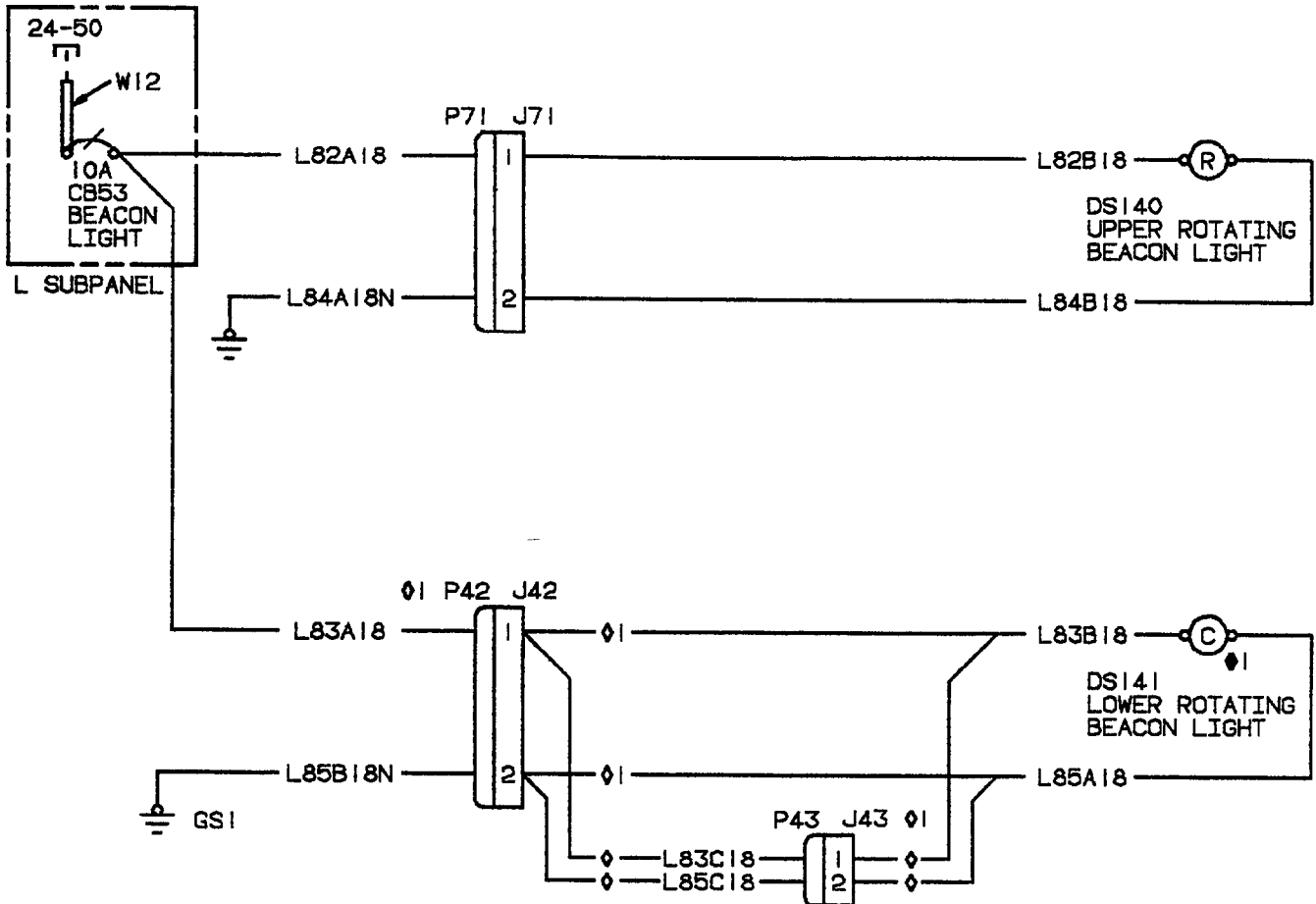

- ◆ ON AIRCRAFT CE-872 THRU CE-1013, RED REPLACES CLEAR.
- ◇ ON AIRCRAFT HAVING OPTIONAL AIR CONDITIONING INSTALLED, WIRES L83C & L85C AND CONNECTORS P/J42 & P/J43 ARE USED. WIRES L83B & L85A ROUTED AS SHOWN.
- ◆ ON AIRCRAFT NOT HAVING OPTIONAL AIR CONDITIONING INSTALLED, WIRES L83B & L85A ROUTED AS SHOWN. CONNECTOR P42 MATES WITH J43. J42 & P43 ARE NOT USED.

C99CE33F2863 C

LIGHTS-ROTATING BEACON (OPTIONAL) (Configuration 1)

Beechcraft
BONANZA
WIRING DIAGRAM MANUAL

REFERENCE DESIGNATOR	PART NUMBER	DESCRIPTION	USABLE	
			INSTL ZONE	ON CODE
33-44-02 (Configuration 1)				
	36-364030-39	LIGHT INSTALLATION-UPPER ROTATING BEACON (NONPROCURABLE)		8
	36-364030-43	LIGHT INSTALLATION-UPPER ROTATING BEACON (NONPROCURABLE)		3
	36-364030-7	LIGHT INSTALLATION-LOWER ROTATING BEACON (NONPROCURABLE)		2
	36-364030-37	LIGHT INSTALLATION-LOWER ROTATING BEACON (NONPROCURABLE)		4
	36-364030-45	LIGHT INSTALLATION-LOWER ROTATING BEACON (NONPROCURABLE)		5
	36-364030-5	LIGHT INSTALLATION-UPPER ROTATING BEACON (NONPROCURABLE)		7
	96-364078-7	LIGHT INSTALLATION-LOWER ROTATING BEACON (NONPROCURABLE)		6
CB53	35-380132-43	CIRCUIT BREAKER-BEACON LIGHT	240	1
DS140A	36-364030-15	LIGHT ASSEMBLY-UPPER ROTATING BEACON (DS140A THRU DS140F USED WITH LIGHT ASSEMBLY 36-364030-15)	253	2
DS140B	D7080A3-24	LIGHT ASSEMBLY	253	2
DS140C	A7079B24	LAMP	253	2
DS140D	A7942	LENS	253	2
DS140E	A7632	GASKET	253	2
DS140F	41-0190-1	MOTOR	253	2
DS140G	36-364036-3	LIGHT ASSEMBLY-UPPER ROTATING BEACON (DS140G THRU DS140P USED WITH LIGHT ASSEMBLY 36-364036-3) (ALTN FOR 36-364030-15)	253	3
DS140H	WRML24CW	LIGHT ASSEMBLY	253	3
DS140J	WRM40	MOTOR	253	3
DS140K	WRM30	GASKET	253	3
DS140L	WRML20L	LENS	253	3
DS140M	WRM1939	LAMP	253	3
DS140N	WRM15	SOCKET	253	3
DS140P	WRM10	DOME	253	3
DS140Q	36-364030-15	LIGHT ASSEMBLY-UPPER ROTATING BEACON (DS140Q THRU DS140T USED WITH LIGHT ASSEMBLY 36-364030-15) (ALTN FOR 36-364036-3)	253	3
DS140R	D7080A3-24	LIGHT ASSEMBLY	253	3
DS140S	A7079B24	LAMP	253	3
DS140T	41-0190-1	MOTOR	253	3
DS141A	36-364030-41	LIGHT ASSEMBLY-LOWER ROTATING BEACON (DS141A THRU DS141F USED WITH LIGHT ASSEMBLY 36-364030-41)	160	2
DS141A	36-364030-41	LIGHT ASSEMBLY-LOWER ROTATING BEACON (DS141A THRU DS141F USED WITH LIGHT ASSEMBLY 36-364030-41) (USED ON AIRPLANES WITH AIR CONDITIONING)	160	4
DS141B	D7080A5-24	LIGHT ASSEMBLY	160	2
DS141B	D7080A5-24	LIGHT ASSEMBLY	160	4
DS141C	A7079B24	LAMP	160	2
DS141C	A7079B24	LAMP	160	4
DS141D	A7942	LENS	160	2
DS141D	A7942	LENS	160	4
DS141E	A7632	GASKET	160	2
DS141E	A7632	GASKET	160	4

Beechcraft BONANZA WIRING DIAGRAM MANUAL

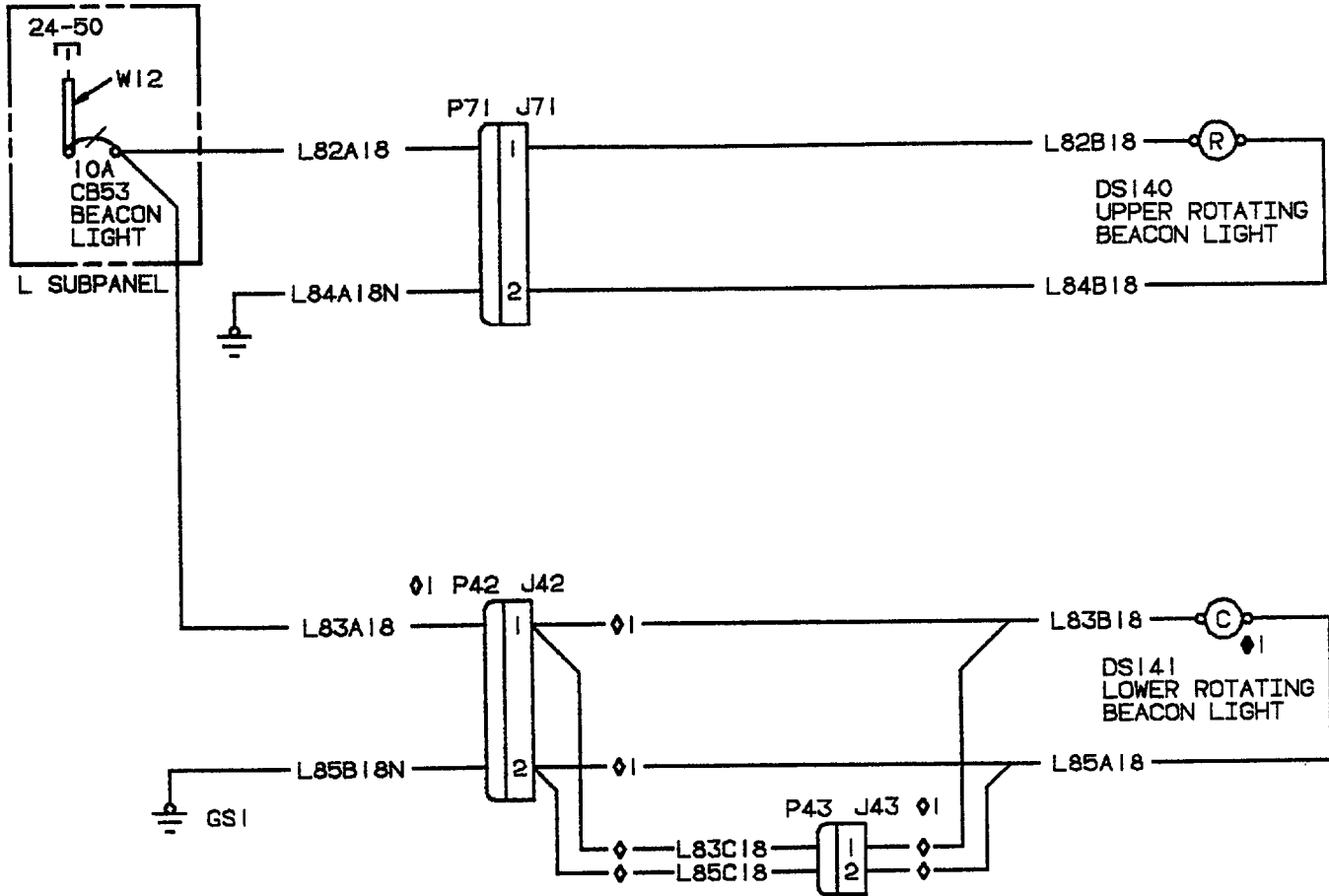

- ◆ ON AIRCRAFT CE-872 THRU CE-1013, RED REPLACES CLEAR.
- ◇ ON AIRCRAFT HAVING OPTIONAL AIR CONDITIONING INSTALLED, WIRES L83C & L85C AND CONNECTORS P/J42 & P/J43 ARE USED. WIRES L83B & L85A ROUTED AS SHOWN.
- ◆ ON AIRCRAFT NOT HAVING OPTIONAL AIR CONDITIONING INSTALLED, WIRES L83B & L85A ROUTED AS SHOWN. CONNECTOR P42 MATES WITH J43. J42 & P43 ARE NOT USED.

C95CE33F2863 C

LIGHTS-ROTATING BEACON (OPTIONAL) (Configuration 1)

Beechcraft BONANZA WIRING DIAGRAM MANUAL

REFERENCE DESIGNATOR	PART NUMBER	DESCRIPTION	USABLE	
			INSTL ZONE	ON CODE
33-44-02 (Configuration 1)				
DS141F	41-0190-3	MOTOR	160	2
DS141F	41-0190-3	MOTOR	160	4
DS141G	36-364036-7	LIGHT ASSEMBLY-LOWER ROTATING BEACON (DS141G THRU DS141P USED WITH LIGHT ASSEMBLY 36-364036-7)	160	5
DS141H	WRML24CCW	LIGHT ASSEMBLY	160	5
DS141J	WRM40	MOTOR	160	5
DS141K	WRM30	GASKET	160	5
DS141L	WRM20L	LENS	160	5
DS141M	WRM1939	LAMP	160	5
DS141N	WRM15	SOCKET	160	5
DS141P	WRM10	DOME	160	5
DS141Q	36-364030-41	LIGHT ASSEMBLY-LOWER ROTATING BEACON (DS141Q THRU DS141T USED WITH LIGHT ASSEMBLY 36-364030-41) (ALTN FOR 36-364036-7)	160	5
DS141R	D7080A5-24	LIGHT ASSEMBLY	160	5
DS141S	A7079B24	LAMP	160	5
DS141T	41-0190-3	MOTOR	160	5
DS141U	102-364031-3	LIGHT ASSEMBLY-LOWER ROTATING BEACON (DS141U THRU DS141ZA USED WITH LIGHT ASSEMBLY 102-364031-3)	160	6
DS141V	40-0100-3C	LIGHT ASSEMBLY	160	6
DS141W	D9961	COVER ASSEMBLY	160	6
DS141X	36112	GASKET	160	6
DS141Y	A7079B24	LAMP	160	6
DS141Z	55-0069-1	MOTOR	160	6
DS141ZA	41-0832-9	ROTATING MECHANISM	160	6
GS1	131270-3	GROUND STUD-MAIN SPAR	270	1
J42A	1-480319-0	RECEPTACLE-LOWER ROTATING BEACON (OPTL)	150	1
J42B	60618-1	PIN CONTACT (OPTL)	150	1
J43A	1-480319-0	RECEPTACLE-LOWER BEACON EXTENTION (OPTL)	150	1
J43B	60618-1	PIN CONTACT (OPTL)	150	1
J71A	1-480319-0	RECEPTACLE-UPPER ROTATING BEACON (OPTL)	310	1
J71B	60618-1	PIN CONTACT (OPTL)	310	1
P42A	1-480318-0	PLUG-LOWER ROTATING BEACON (OPTL)	150	1
P42B	60617-1	SOCKET CONTACT (OPTL)	150	1
P43A	1-480318-0	PLUG-LOWER BEACON EXTENTION (OPTL)	150	1
P43B	60617-1	SOCKET CONTACT (OPTL)	150	1
P71A	1-480318-0	PLUG-UPPER ROTATING BEACON (OPTL)	310	1
P71B	60617-1	SOCKET CONTACT (OPTL)	310	1

Beechcraft BONANZA WIRING DIAGRAM MANUAL

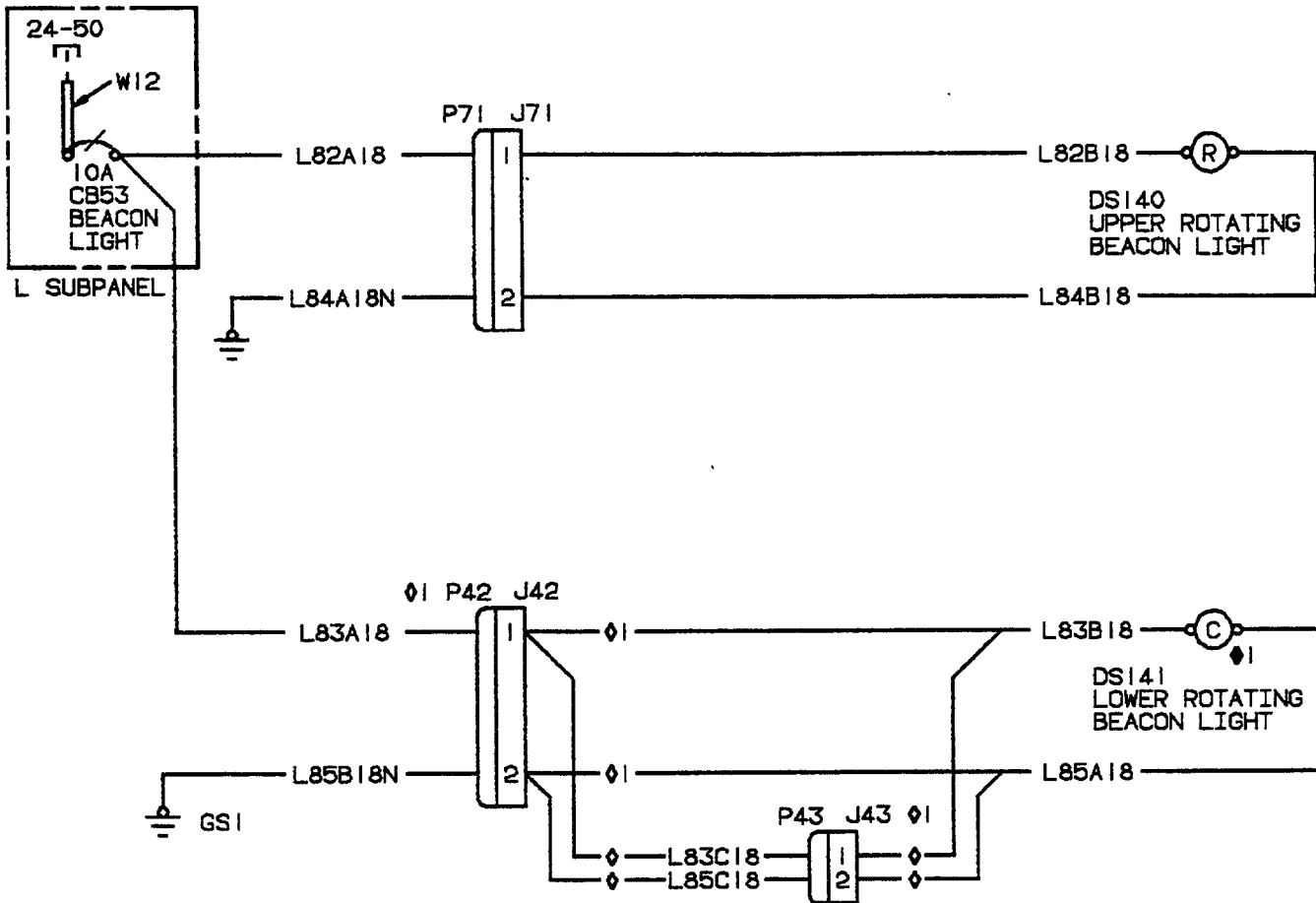

- ◆ ON AIRCRAFT CE-872 THRU CE-1013, RED REPLACES CLEAR.
- ◇ ON AIRCRAFT HAVING OPTIONAL AIR CONDITIONING INSTALLED, WIRES L83C & L85C AND CONNECTORS P/J42 & P/J43 ARE USED. WIRES L83B & L85A ROUTED AS SHOWN.
- ◆ ON AIRCRAFT NOT HAVING OPTIONAL AIR CONDITIONING INSTALLED, WIRES L83B & L85A ROUTED AS SHOWN. CONNECTOR P42 MATES WITH J43. J42 & P43 ARE NOT USED.

C95CE33F2863 C

LIGHTS-ROTATING BEACON (OPTIONAL) (Configuration 1)

Beechcraft
BONANZA
WIRING DIAGRAM MANUAL

REFERENCE DESIGNATOR	PART NUMBER	DESCRIPTION	USABLE INSTL ON ZONE CODE
		33-44-02 (Configuration 1)	
W12	114931-1-6	BUS LIGHT	240 1

EFFECTIVITY CODE

1. CE-872 AND AFTER; CJ-151 AND AFTER
2. CE-872 THRU CE-973; CJ-151 THRU CJ-155
3. CE-974 AND AFTER; CJ-156 AND AFTER
4. CE-872 AND AFTER
5. CE-974 THRU CE-1013; CJ-156 AND AFTER
6. CE-1014 AND AFTER
7. CE-872 THRU CE-918, CE-920 THRU CE-922, CE-924, CE-926, CE-928; CJ-151 THRU CJ-155
8. CE-919, CE-923, CE-925, CE-927, CE-929 THRU CE-973

Beechcraft
BONANZA
WIRING DIAGRAM MANUAL

33-44-02

Configuration 2

D-10269 AND AFTER

Beechcraft BONANZA WIRING DIAGRAM MANUAL

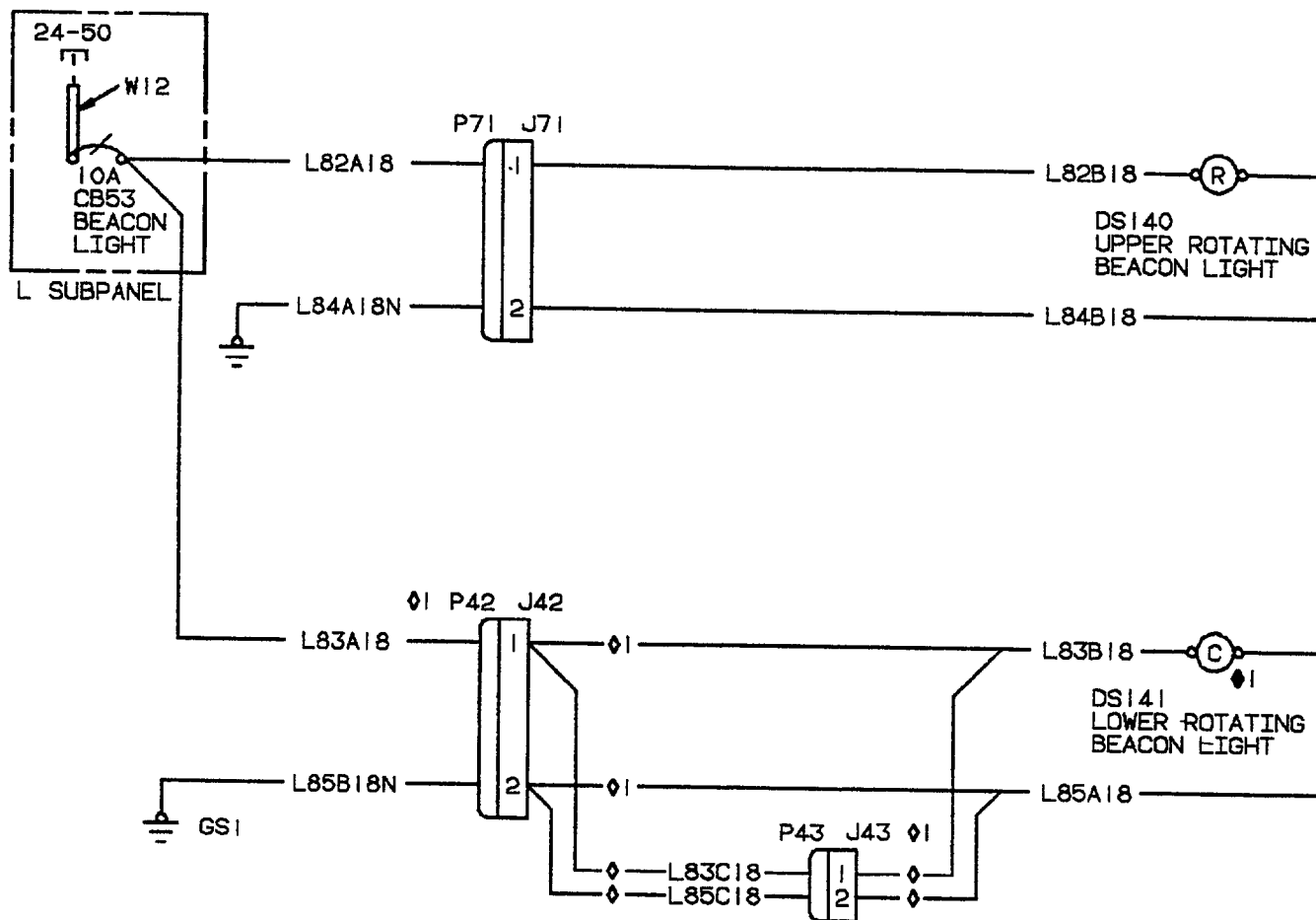

- ◆ ON AIRCRAFT D-10269 THRU D-10403, RED REPLACES CLEAR.
- ◇ ON AIRCRAFT HAVING OPTIONAL AIR CONDITIONING INSTALLED, WIRES L83C & L85C AND CONNECTORS P/J42 & P/J43 ARE USED. WIRES L83B & L85A ROUTED AS SHOWN.
- ◇ ON AIRCRAFT NOT HAVING OPTIONAL AIR CONDITIONING INSTALLED, WIRES L83B & L85A ROUTED AS SHOWN. CONNECTOR P42 MATES WITH J43. J42 & P43 ARE NOT USED.

C96CE33F2864 C

LIGHTS-ROTATING BEACON (OPTIONAL) (Configuration 2)

Beechcraft BONANZA WIRING DIAGRAM MANUAL

REFERENCE DESIGNATOR	PART NUMBER	DESCRIPTION	USABLE INSTL ON ZONE CODE
33-44-02 (Configuration 2)			
	36-364030-5	LIGHT INSTALLATION-UPPER ROTATING BEACON (NONPROCURABLE)	2
	36-364030-39	LIGHT INSTALLATION-UPPER ROTATING BEACON (NONPROCURABLE)	7
	36-364030-43	LIGHT INSTALLATION-UPPER ROTATING BEACON (NONPROCURABLE)	3
	36-364030-7	LIGHT INSTALLATION-LOWER ROTATING BEACON (NONPROCURABLE)	4
	36-364030-37	LIGHT INSTALLATION-LOWER ROTATING BEACON (NONPROCURABLE)	5
	36-364030-45	LIGHT INSTALLATION-LOWER ROTATING BEACON (NONPROCURABLE)	3
	96-364078-7	LIGHT INSTALLATION-LOWER ROTATING BEACON (NONPROCURABLE)	6
CB53	35-380132-43	CIRCUIT BREAKER-BEACON LIGHT	240 1
DS140A	36-364030-15	LIGHT ASSEMBLY-UPPER ROTATING BEACON (DS140A THRU DS140F USED WITH LIGHT ASSEMBLY 36-364030-15)	253 2
DS140B	D7080A1-24	LIGHT ASSEMBLY	253 2
DS140C	A7079B24	LAMP	253 2
DS140D	A7942	LENS	253 2
DS140E	A7632	GASKET	253 2
DS140F	41-0190-1	MOTOR	253 2
DS140G	36-364036-3	LIGHT ASSEMBLY-UPPER ROTATING BEACON (DS140G THRU DS140P USED WITH LIGHT ASSEMBLY 36-364036-3) (ALTN FOR 36-364030-15)	253 3
DS140H	WRML24CW	LIGHT ASSEMBLY	253 3
DS140J	WRM40	MOTOR	253 3
DS140K	WRM30	GASKET	253 3
DS140L	WRML20	LENS	253 3
DS140M	WRM1939	LAMP	253 3
DS140N	WRM15	SOCKET	253 3
DS140P	WRM10	DOME	253 3
DS140Q	36-364030-15	LIGHT ASSEMBLY-UPPER ROTATING BEACON (DS140Q THRU DS140T USED WITH LIGHT ASSEMBLY 36-364030-15) (ALTN FOR 36-364036-3)	253 3
DS140R	D7080A1-24	LIGHT ASSEMBLY	253 3
DS140S	A7079B24	LAMP	253 3
DS140T	41-0190-1	MOTOR	253 3
DS141A	36-364030-41	LIGHT ASSEMBLY-LOWER ROTATING BEACON (DS141A THRU DS141F USED WITH LIGHT ASSEMBLY 36-364030-41) (USED ON AIRPLANES WITHOUT AIR CONDITIONING)	160 4
DS141A	36-364030-41	LIGHT ASSEMBLY-LOWER ROTATING BEACON (DS141A THRU DS141F USED WITH LIGHT ASSEMBLY 36-364030-41) (ALTN FOR 36-364036-7)	160 5
DS141B	D7080A5-24	LIGHT ASSEMBLY	160 4
DS141B	D7080A5-24	LIGHT ASSEMBLY	160 5
DS141C	A7079B24	LAMP	160 4
DS141C	A7079B24	LAMP	160 5
DS141D	A7942	LENS	160 4
DS141D	A7942	LENS	160 5
DS141E	A7632	GASKET	160 4

Beechcraft BONANZA WIRING DIAGRAM MANUAL

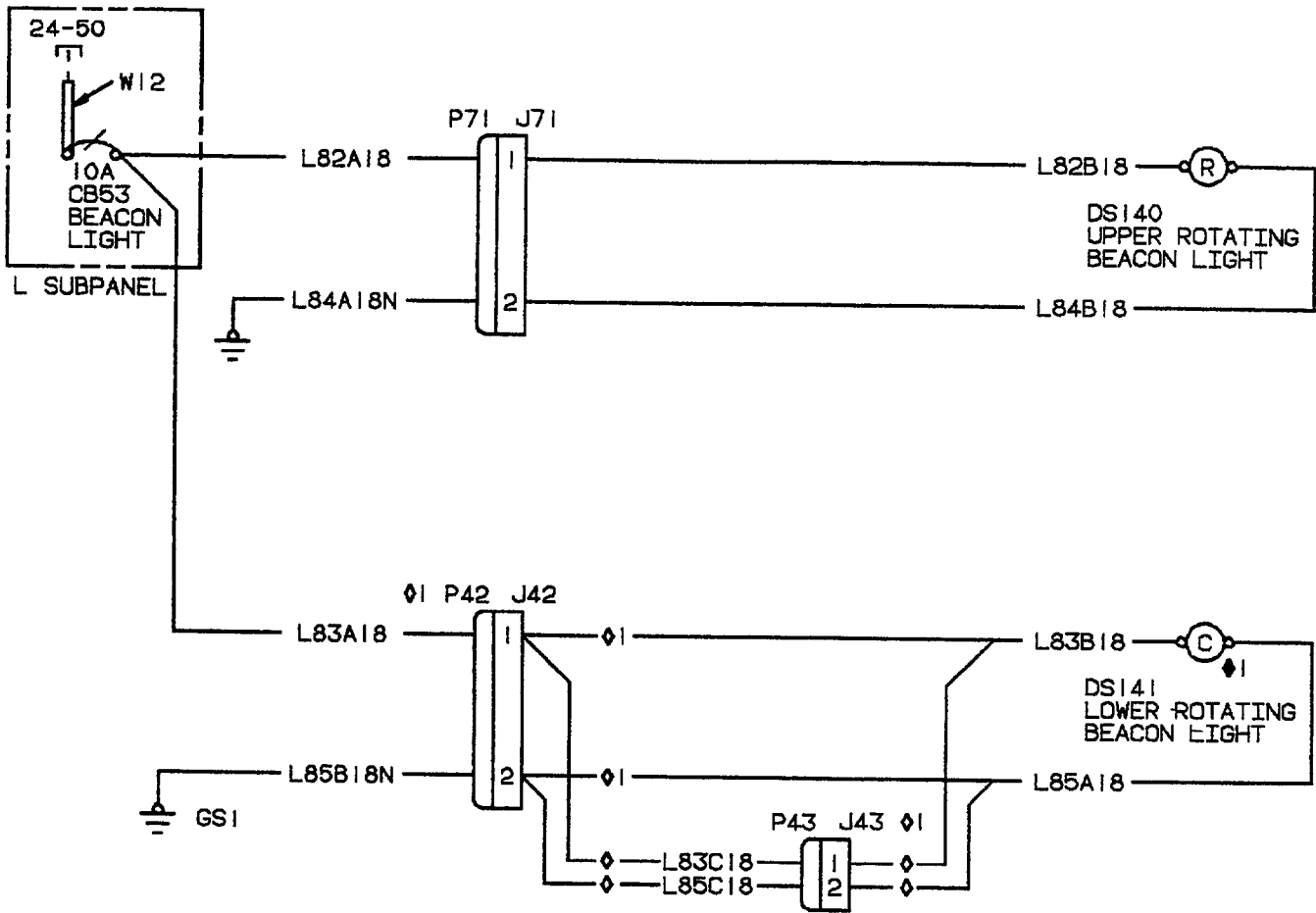

- ◆ ON AIRCRAFT D-10269 THRU D-10403. RED REPLACES CLEAR.
- ◇ ON AIRCRAFT HAVING OPTIONAL AIR CONDITIONING INSTALLED. WIRES L83C & L85C AND CONNECTORS P/J42 & P/J43 ARE USED. WIRES L83B & L85A ROUTED AS SHOWN.
- ◇ ON AIRCRAFT NOT HAVING OPTIONAL AIR CONDITIONING INSTALLED. WIRES L83B & L85A ROUTED AS SHOWN. CONNECTOR P42 MATES WITH J43. J42 & P43 ARE NOT USED.

C95CE33F2864 C

LIGHTS-ROTATING BEACON (OPTIONAL) (Configuration 2)

Beechcraft BONANZA WIRING DIAGRAM MANUAL

REFERENCE DESIGNATOR	PART NUMBER	DESCRIPTION	INSTL	USABLE ON ZONE CODE
33-44-02 (Configuration 2)				
DS141E	A7632	GASKET	160	5
DS141F	41-0190-1	MOTOR	160	4
DS141F	41-0190-1	MOTOR	160	5
DS141G	36-364036-7	LIGHT ASSEMBLY-LOWER ROTATING BEACON (DS141G THRU DS141P USED WITH LIGHT ASSEMBLY 36-364036-7) (USED ONLY WHEN 36-364030-5, 36-364030-39 OR 36-364030-43 LIGHT INSTALLATION IS USED)	160	3
DS141G	36-364036-7	LIGHT ASSEMBLY-LOWER ROTATING BEACON (DS141G THRU DS141P USED WITH LIGHT ASSEMBLY 36-364036-7) (ALTN FOR 36-364030-41)	160	5
DS141H	WRML24CCW	LIGHT ASSEMBLY	160	3
DS141H	WRML24CCW	LIGHT ASSEMBLY	160	5
DS141J	WRM40	MOTOR	160	3
DS141J	WRM40	MOTOR	160	5
DS141K	WRM30	GASKET	160	3
DS141K	WRM30	GASKET	160	5
DS141L	WRM20L	LENS	160	3
DS141L	WRM20L	LENS	160	5
DS141M	WRM1939	LAMP	160	3
DS141M	WRM1939	LAMP	160	5
DS141N	WRM15	SOCKET	160	3
DS141N	WRM15	SOCKET	160	5
DS141P	WRM10	DOME	160	3
DS141P	WRM10	DOME	160	5
DS141U	102-364031-3	LIGHT ASSEMBLY-LOWER ROTATING BEACON (DS141U THRU DS141ZA USED WITH LIGHT ASSEMBLY 102-364031-3)	160	5
DS141V	40-0100-3C	LIGHT ASSEMBLY	160	5
DS141W	D9961	COVER ASSEMBLY	160	5
DS141X	36112	GASKET	160	5
DS141Y	A7079B24	LAMP	160	5
DS141Z	55-0069-1	MOTOR	160	5
DS141ZA	41-0832-9	ROTATING MECHANISM	160	5
GS1	131270-3	GROUND STUD-MAIN SPAR	270	1
J42A	1-480319-0	RECEPTACLE-LOWER ROTATING BEACON (OPTL)	150	1
J42B	60618-1	PIN CONTACT (OPTL)	150	1
J43A	1-480319-0	RECEPTACLE-LOWER BEACON EXTENTION (OPTL)	150	1
J43B	60618-1	PIN CONTACT (OPTL)	150	1
J71A	1-480319-0	RECEPTACLE-UPPER ROTATING BEACON (OPTL)	310	1
J71B	60618-1	PIN CONTACT (OPTL)	310	1
P42A	1-480318-0	PLUG-LOWER ROTATING BEACON (OPTL)	150	1
P42B	60617-1	SOCKET CONTACT (OPTL)	150	1
P43A	1-480318-0	PLUG-LOWER BEACON EXTENTION (OPTL)	150	1
P43B	60617-1	SOCKET CONTACT (OPTL)	150	1
P71A	1-480318-0	PLUG-UPPER ROTATING BEACON (OPTL)	310	1
P71B	60617-1	SOCKET CONTACT (OPTL)	310	1

Beechcraft BONANZA WIRING DIAGRAM MANUAL

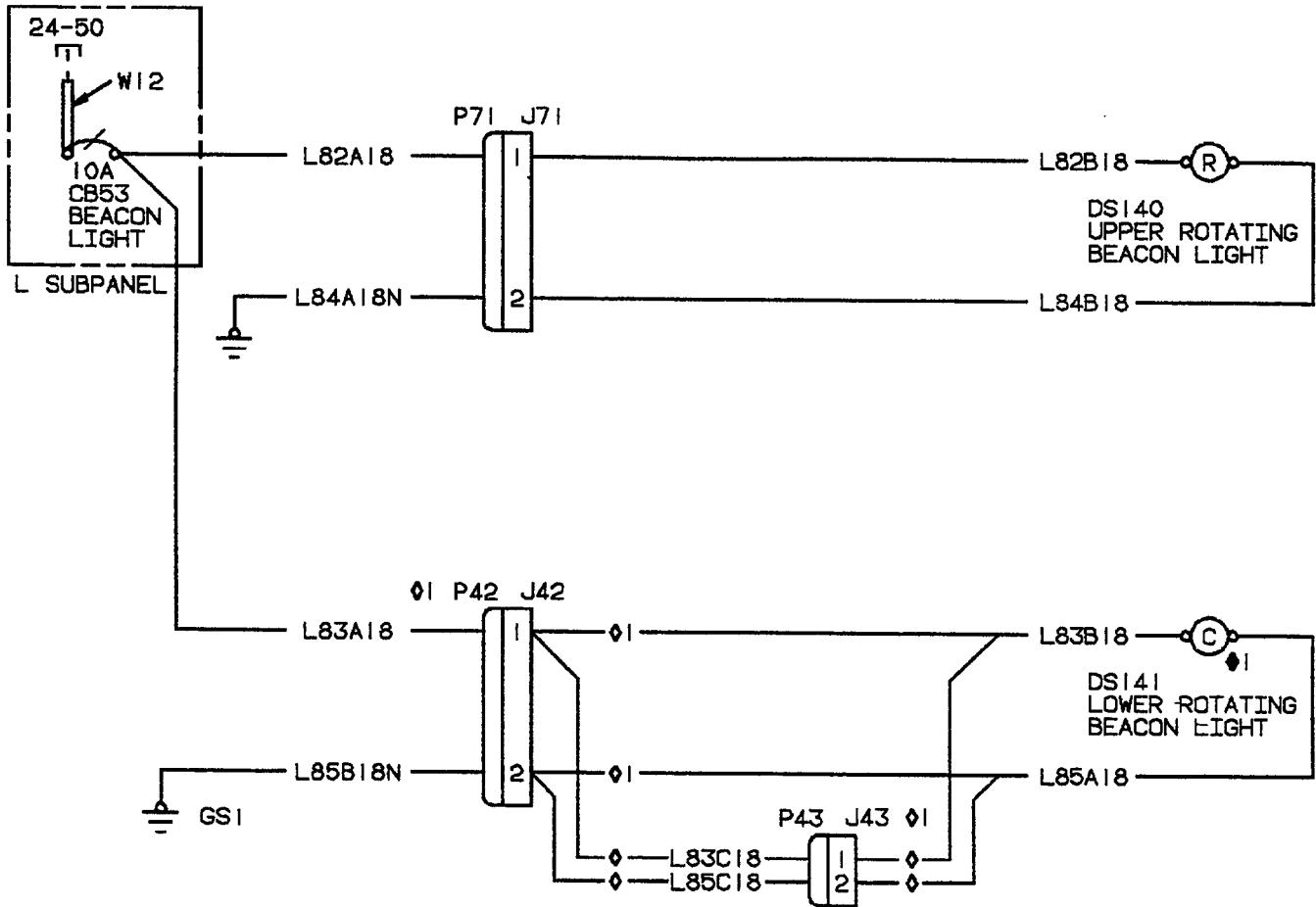

- ◆ ON AIRCRAFT D-10269 THRU D-10403, RED REPLACES CLEAR.
- ◇ ON AIRCRAFT HAVING OPTIONAL AIR CONDITIONING INSTALLED, WIRES L83C & L85C AND CONNECTORS P/J42 & P/J43 ARE USED. WIRES L83B & L85A ROUTED AS SHOWN.
- ◇ ON AIRCRAFT NOT HAVING OPTIONAL AIR CONDITIONING INSTALLED, WIRES L83B & L85A ROUTED AS SHOWN. CONNECTOR P42 MATES WITH J43. J42 & P43 ARE NOT USED.

C95CE33F2864 C

LIGHTS-ROTATING BEACON (OPTIONAL) (Configuration 2)

Beechcraft
BONANZA
WIRING DIAGRAM MANUAL

REFERENCE DESIGNATOR	PART NUMBER	DESCRIPTION	USABLE INSTL ON ZONE CODE
		33-44-02 (Configuration 2)	
W12	114931-1-6	BUS LIGHT	240 1

EFFECTIVITY CODE

1. D-10269 AND AFTER
2. D-10269 THRU D-10347, D-10349 THRU D-10352
3. D-10391 THRU D-10403
4. D-10269 THRU D-10390
5. D-10269 THRU D-10382
6. D-10404 AND AFTER
7. D-10348, D-10353 THRU D-10390

Beechcraft
BONANZA
WIRING DIAGRAM MANUAL

33-44-02

Configuration 3

**E-1552 THRU E-1945, E-1947 THRU E-2103, E-2105 THRU E-2110;
EA-12 THRU EA-319, EA-321 THRU EA-388**

Beechcraft BONANZA WIRING DIAGRAM MANUAL

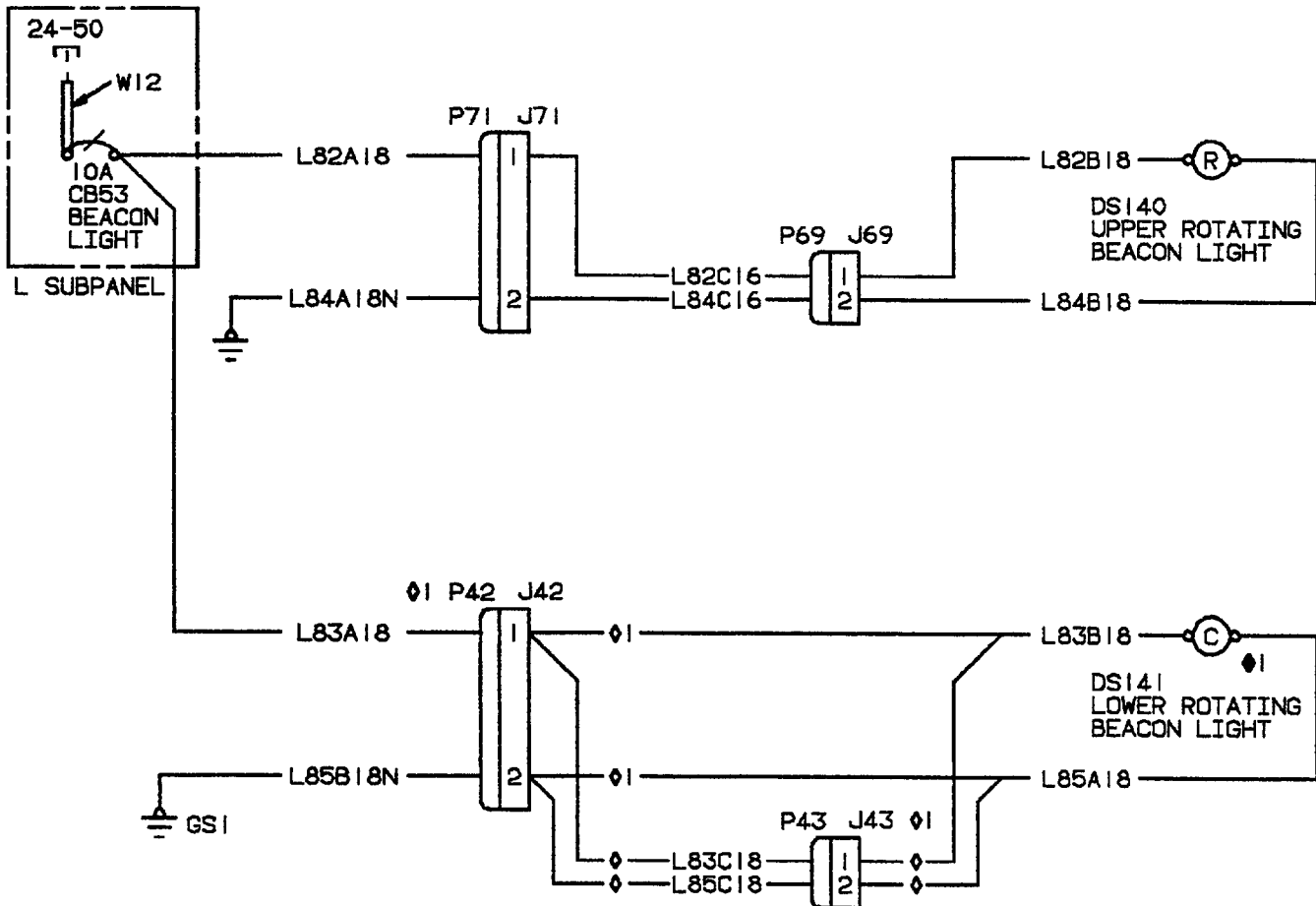

- ◆ ON AIRCRAFT E-1552 THRU E-2051, EA-12 THRU EA-319, EA-321 THRU EA-326, RED REPLACES CLEAR.
- ◆ ON AIRCRAFT HAVING OPTIONAL AIR CONDITIONING INSTALLED, WIRES L83C & L85C AND CONNECTORS P/J42 & P/J43 ARE USED. WIRES L83B & L85A ROUTED AS SHOWN.
- ◆ ON AIRCRAFT NOT HAVING OPTIONAL AIR CONDITIONING INSTALLED, WIRES L83B & L85A ROUTED AS SHOWN. CONNECTOR P42 MATES WITH J43. J42 & P43 ARE NOT USED.

C98CE33F2862 C

LIGHTS-ROTATING BEACON (OPTIONAL) (Configuration 3)

Beechcraft
BONANZA
WIRING DIAGRAM MANUAL

REFERENCE DESIGNATOR	PART NUMBER	DESCRIPTION	USABLE	
			INSTL ZONE	ON CODE
33-44-02 (Configuration 3)				
	96-364078-7	LIGHT INSTALLATION-LOWER ROTATING BEACON (NONPROCURABLE)		6
	36-364030-1	LIGHT INSTALLATION-UPPER ROTATING BEACON (NONPROCURABLE)		1
	36-364030-7	LIGHT INSTALLATION-LOWER ROTATING BEACON (NONPROCURABLE)		2
	36-364030-37	LIGHT INSTALLATION-LOWER ROTATING BEACON (NONPROCURABLE)		3
	36-364030-45	LIGHT INSTALLATION-LOWER ROTATING BEACON (NONPROCURABLE)		5
CB53	35-380132-43	CIRCUIT BREAKER-BEACON LIGHT	240	1
DS140A	36-364030-13	LIGHT ASSEMBLY-UPPER ROTATING BEACON (DS140A THRU DS140F USED WITH LIGHT ASSEMBLY 36-364030-13)	330	1
DS140B	D7080A3-24	LIGHT ASSEMBLY	330	1
DS140C	A7079B24	LAMP	330	1
DS140D	A7942	LENS	330	1
DS140E	A7632	GASKET	330	1
DS140F	41-0190-1	MOTOR	330	1
DS141G	36-364030-41	LIGHT ASSEMBLY-LOWER ROTATING BEACON (DS141G THRU DS141M USED WITH LIGHT ASSEMBLY 36-364030-41)	160	2
DS141G	36-364030-11	LIGHT ASSEMBLY-LOWER ROTATING BEACON (DS141G THRU DS141M USED WITH LIGHT ASSEMBLY 36-364030-11)	160	3
DS141H	D7080A5-24	LIGHT ASSEMBLY	160	2
DS141H	D7080A5-24	LIGHT ASSEMBLY	160	3
DS141J	A7079B24	LAMP	160	2
DS141J	A7079B24	LAMP	160	3
DS141K	A7942	LENS	160	2
DS141K	A7942	LENS	160	3
DS141L	A7632	GASKET	160	2
DS141L	A7632	GASKET	160	3
DS141M	41-0109-3	MOTOR	160	2
DS141M	41-0109-3	MOTOR	160	3
DS141N	36-364036-7	LIGHT ASSEMBLY-LOWER ROTATING BEACON (DS141N THRU DS141V USED WITH LIGHT ASSEMBLY 36-364036-7)	160	4
DS141N	36-364036-7	LIGHT ASSEMBLY-LOWER ROTATING BEACON (DS141N THRU DS141V USED WITH LIGHT ASSEMBLY 36-364036-7)	160	5
DS141P	WRML24CCW	LIGHT ASSEMBLY	160	4
DS141P	WRML24CCW	LIGHT ASSEMBLY	160	5
DS141Q	WRM40	MOTOR	160	4
DS141Q	WRM40	MOTOR	160	5
DS141R	WRM30	GASKET	160	4
DS141R	WRM30	GASKET	160	5
DS141S	WRM20L	LENS	160	4
DS141S	WRM20L	LENS	160	5
DS141T	WRM1939	LAMP	160	4
DS141T	WRM1939	LAMP	160	5
DS141U	WRM15	SOCKET	160	4
DS141U	WRM15	SOCKET	160	5
DS141V	WRM10	DOME	160	4
DS141V	WRM10	DOME	160	5

Beechcraft BONANZA WIRING DIAGRAM MANUAL

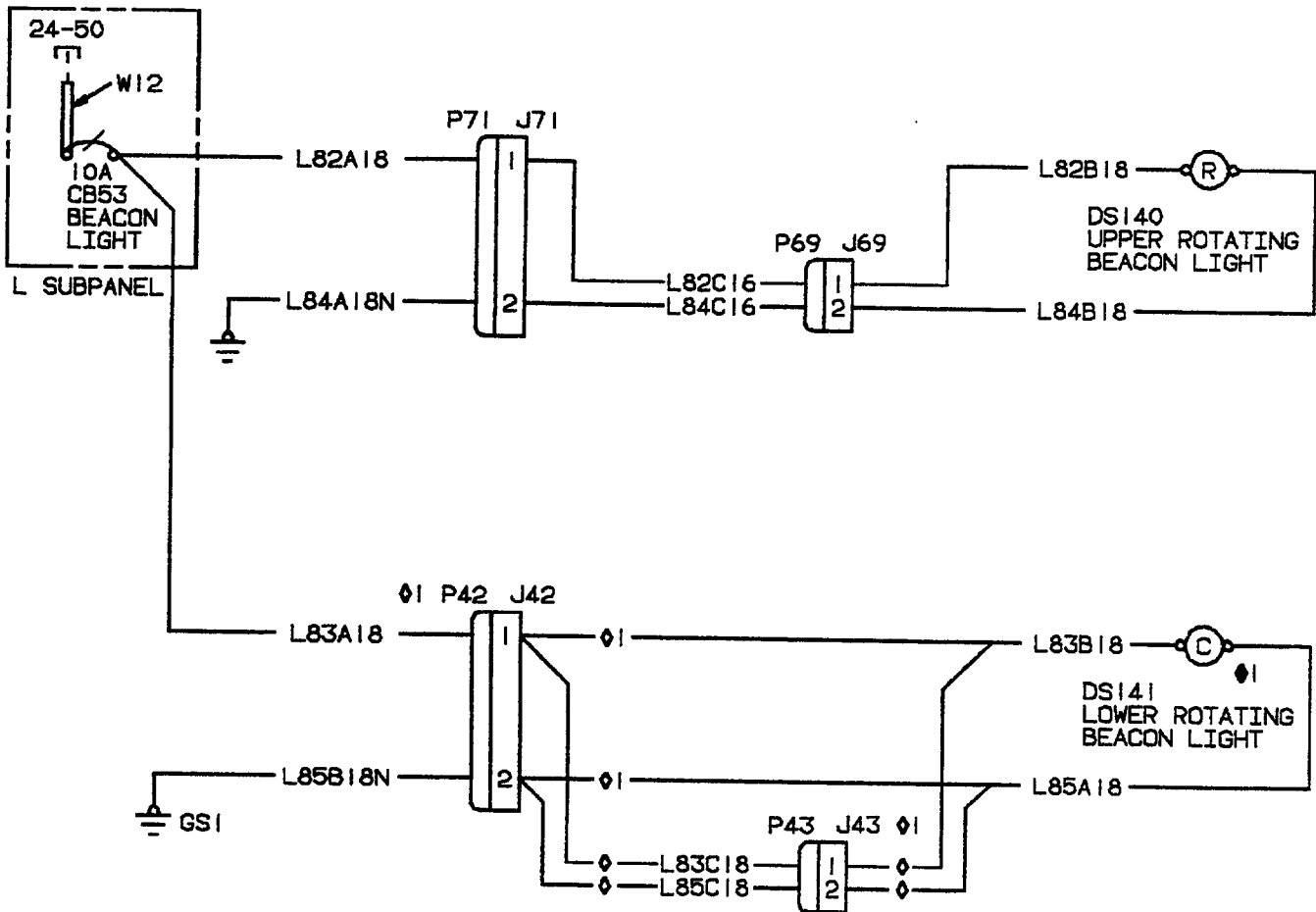

- ◆ ON AIRCRAFT E-1552 THRU E-2051, EA-12 THRU EA-319, EA-321 THRU EA-326, RED REPLACES CLEAR.
- ◆ ON AIRCRAFT HAVING OPTIONAL AIR CONDITIONING INSTALLED, WIRES L83C & L85C AND CONNECTORS P/J42 & P/J43 ARE USED. WIRES L83B & L85A ROUTED AS SHOWN.
- ◆ ON AIRCRAFT NOT HAVING OPTIONAL AIR CONDITIONING INSTALLED, WIRES L83B & L85A ROUTED AS SHOWN. CONNECTOR P42 MATES WITH J43. J42 & P43 ARE NOT USED.

C96CE33F2862 C

LIGHTS-ROTATING BEACON (OPTIONAL) (Configuration 3)

Beechcraft BONANZA WIRING DIAGRAM MANUAL

REFERENCE DESIGNATOR	PART NUMBER	DESCRIPTION	USABLE INSTL ON ZONE CODE
33-44-02 (Configuration 3)			
DS141W	102-364031-3	LIGHT ASSEMBLY-LOWER ROTATING BEACON (DS141W THRU DS141ZC USED WITH LIGHT ASSEMBLY 102-364031-3)	160 6
DS141X	40-0100-3C	LIGHT ASSEMBLY	160 6
DS141Y	D9961-3	COVER ASSEMBLY	160 6
DS141Z	36112	GASKET	160 6
DS141ZA	A7079B24	LAMP	160 6
DS141ZB	55-0069-1	MOTOR	160 6
DS141ZC	41-0832-9	ROTATING MECHANISM	160 6
GS1	131270-3	GROUND STUD-MAIN SPAR	270 1
J42A	1-480319-0	RECEPTACLE-LOWER ROTATING BEACON (OPTL)	150 1
J42B	60618-1	PIN CONTACT (OPTL)	150 1
J43A	1-480319-0	RECEPTACLE-LOWER BEACON EXTENTION (OPTL)	150 1
J43B	60618-1	PIN CONTACT (OPTL)	150 1
J69A	1-480319-0	RECEPTACLE-UPPER ROTATING BEACON (OPTL)	330 1
J69B	60618-1	PIN CONTACT (OPTL)	330 1
J71A	1-480319-0	RECEPTACLE-UPPER ROTATING BEACON (OPTL)	310 1
J71B	60618-1	PIN CONTACT (OPTL)	310 1
P42A	1-480318-0	PLUG-LOWER ROTATING BEACON (OPTL)	150 1
P42B	60617-1	SOCKET CONTACT (OPTL)	150 1
P43A	1-480318-0	PLUG-LOWER BEACON EXTENTION (OPTL)	150 1
P43B	60617-1	SOCKET CONTACT (OPTL)	150 1
P69A	1-480318-0	PLUG-UPPER BEACON EXTENTION (OPTL)	330 1
P69B	60617-1	SOCKET CONTACT (OPTL)	330 1
P71A	1-480318-0	PLUG-UPPER ROTATING BEACON (OPTL)	310 1
P71B	60617-1	SOCKET CONTACT (OPTL)	310 1
W12	114931-1-6	BUS LIGHT	240 1

EFFECTIVITY CODE

1. E-1552 THRU E-1945, E-1947 THRU E-2103, E-2105 THRU E-2110; EA-12 THRU EA-319, EA-321 THRU EA-388
2. E-1552 THRU E-1941; EA-12 THRU EA-287
3. E-1552 THRU E-1941 (ON AIRPLANES WITH AIR CONDITIONING)
4. E-1942 THRU E-1945, E-1947 THRU E-2103, E-2105 THRU E-2110 (ON AIRPLANES WITH AIR CONDITIONING)
5. E-1942 THRU E-1945, E-1947 THRU E-2051; EA-288 THRU EA-319, EA-321 THRU EA-326
6. E-2052 THRU E-2103, E-2105 THRU E-2110; EA-327 THRU EA-388

Beechcraft
BONANZA
WIRING DIAGRAM MANUAL

33-45-01

Configuration 1

**E-1111, E-1241 THRU E-1945, E-1947 THRU E-2103, E-2105 THRU
E-2110; CE-748, CE-772 THRU CE-1664; CJ-149 THRU CJ-179;
D-10097, D-10120 AND AFTER; EA-1 THRU EA-319, EA-321 THRU
EA-388**

Beechcraft BONANZA WIRING DIAGRAM MANUAL

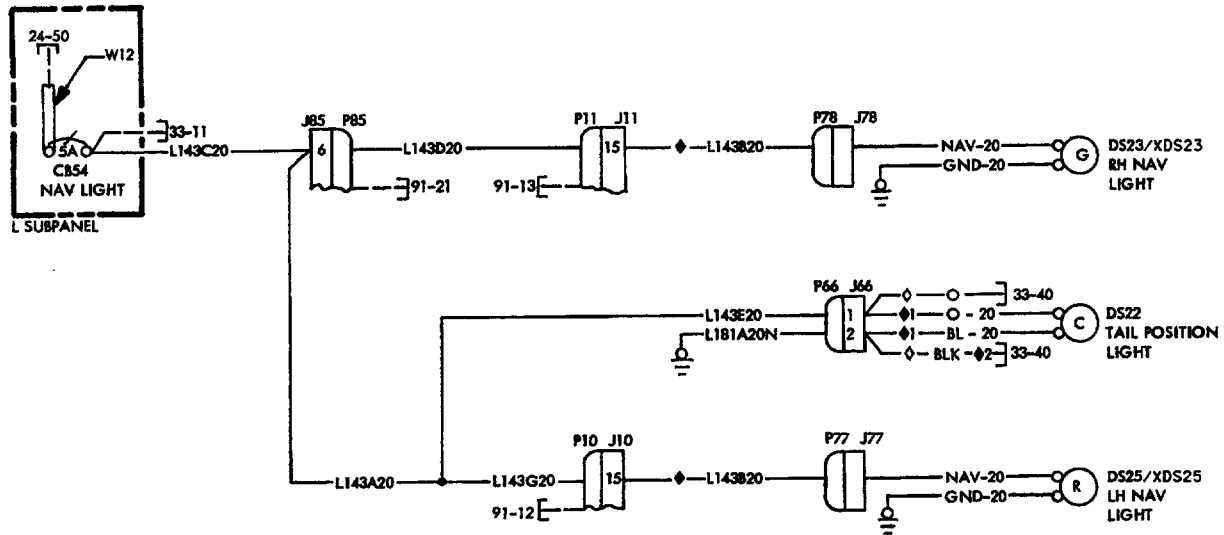

◆ ON AIRCRAFT HAVING OPTIONAL STROBE LIGHTS INSTALLED, CONN J66 AND WIRES O AND BL CONNECTED AS SHOWN (REF DIAGRAM 33-40).

◆ WIRE NUMBER DUPLICATED FOR LEFT AND RIGHT WIRE HARNESS INTERCHANGEABILITY.

◆1 ON AIRCRAFT NOT HAVING OPTIONAL STROBE LIGHTS INSTALLED, CONN J66 AND WIRES O-20 & BL-20 CONNECTED TO DS84 - RH NAV LIGHT AS SHOWN.

◆2 ON AIRCRAFT E-1111, E-1241 THRU E-1470, CE-748, CE-772 THRU CE-850, C-149, D-10097 & D-10120 THRU D-10241, BLUE WIRE REPLACES BLACK WIRE.

LIGHTS-NAVIGATION (Configuration 1)

Beechcraft
BONANZA
WIRING DIAGRAM MANUAL

REFERENCE DESIGNATOR	PART NUMBER	DESCRIPTION	INSTL ZONE	USABLE ON CODE
33-45-01 (Configuration 1)				
CB54	35-380132-41	CIRCUIT BREAKER-NAVIGATION LIGHT	240	1
DS22	A2064-1683	LIGHT-TAIL POSITION	370	1
DS23	A7512-24	LIGHT-RIGHT WING NAVIGATION	650	1
DS25	A7512-24	LIGHT-LEFT WING NAVIGATION	550	1
J10A	206036-3	RECEPTACLE-LEFT WHEEL WELL ACCESS	532	1
J10B	206070-1	STRAIN RELIEF	532	1
J10C	66103-2	PIN CONTACT	532	1
J10D	66099-2	PIN CONTACT	532	1
J11A	206036-3	RECEPTACLE-WHEEL WELL ACCESS, RIGHT	632	1
J11B	206070-1	STRAIN RELIEF	632	1
J11C	66099-2	PIN CONTACT	632	1
J11D	66103-2	PIN CONTACT	632	1
J66A	1-480319-0	RECEPTACLE-TAIL POSITION LIGHT	310	1
J66B	60618-1	PIN CONTACT	310	1
J77A	1-480351-0	RECEPTACLE-LEFT WING NAVIGATION LIGHT	550	1
J77B	60618-1	PIN CONTACT	550	1
J78A	1-480351-0	RECEPTACLE-RIGHT WING NAVIGATION LIGHT	650	1
J78B	60618-1	PIN CONTACT	650	1
J85A	1-480288-0	RECEPTACLE-CROSSOVER DISCONNECT	251	1
J85B	60618-1	PIN CONTACT	251	1
P10A	206037-1	PLUG-LEFT WHEEL WELL ACCESS	532	1
P10B	66101-2	SOCKET CONTACT	532	1
P10C	66105-2	SOCKET CONTACT	532	1
P10D	206070-1	STRAIN RELIEF CLAMP	532	1
P11A	206037-1	PLUG-WHEEL WELL ACCESS, RIGHT	632	1
P11B	206070-1	STRAIN RELIEF	632	1
P11C	66101-2	SOCKET CONTACT	632	1
P11D	66105-2	SOCKET CONTACT	632	1
P66A	1-480318-0	PLUG-TAIL POSITION LIGHT	310	1
P66B	60617-1	SOCKET CONTACT	310	1
P77A	1-480349-0	PLUG-LEFT WING NAVIGATION LIGHT	550	1
P77B	60617-1	SOCKET CONTACT	550	1
P78A	1-480349-0	PLUG-RIGHT WING NAVIGATION LIGHT	650	1
P78B	60617-1	SOCKET CONTACT	650	1
P85A	1-480287-0	PLUG-CROSSOVER DISCONNECT	251	1
P85B	66017-1	SOCKET CONTACT	251	1
W12	114931-1-6	BUS LIGHT	240	1
XDS23	A1815A-6-7512	LAMPHOLDER-RIGHT WING NAVIGATION LIGHT	650	1
XDS25	A1815A-R-7512	LAMPHOLDER-LEFT WING NAVIGATION LIGHT	550	1

EFFECTIVITY CODE

1. E-1111, E-1241 THRU E-1945, E-1947 THRU E-2103, E-2105 THRU E-2110; CE-748, CE-772 THRU CE-1664; CJ-149 THRU CJ-179; D-10097, D-10120 AND AFTER; EA-1 THRU EA-319, EA-321 THRU EA-388

Beechcraft
BONANZA
WIRING DIAGRAM MANUAL

33-45-01

Configuration 2

CE-1165 AND AFTER; CJ-180 AND AFTER

Beechcraft BONANZA WIRING DIAGRAM MANUAL

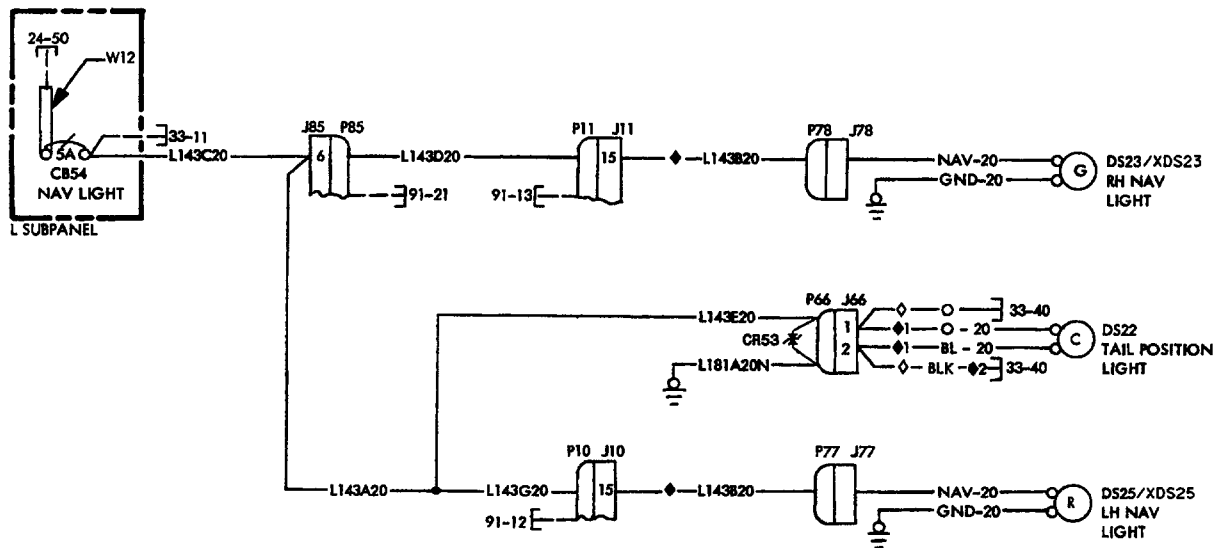

◆ ON AIRCRAFT HAVING OPTIONAL STROBE LIGHTS INSTALLED, CONN J66 AND WIRES O AND BL CONNECTED AS SHOWN (REF DIAGRAM 33-40).

◆ WIRE NUMBER DUPLICATED FOR LEFT AND RIGHT WIRE HARNESS INTERCHANGEABILITY.

◆1 ON AIRCRAFT NOT HAVING OPTIONAL STROBE LIGHTS INSTALLED, CONN J66 AND WIRES O-20 & BL-20 CONNECTED TO DS84 - RH NAV LIGHT AS SHOWN.

◆2 ON AIRCRAFT E-1111, E-1241 THRU E-1470, CE-748, CE-772 THRU CE-850, CJ-149, D-10097 & D-10120 THRU D-10241, BLUE WIRE REPLACES BLACK WIRE.

LIGHTS-NAVIGATION (Configuration 2)

Beechcraft
BONANZA
WIRING DIAGRAM MANUAL

REFERENCE DESIGNATOR	PART NUMBER	DESCRIPTION	USABLE INSTL ON ZONE CODE
33-45-01 (Configuration 2)			
CB54	35-380132-41	CIRCUIT BREAKER-NAVIGATION LIGHT	240 1
CR53	1.5KE51AC	TRANSZORB	310 1
DS22	A2064-1683	LIGHT-TAIL POSITION	370 1
DS23	A7512-24	LIGHT-RIGHT WING NAVIGATION	650 1
DS25	A7512-24	LIGHT-LEFT WING NAVIGATION	550 1
J10A	206036-3	RECEPTACLE-LEFT WHEEL WELL ACCESS	532 1
J10B	206070-1	STRAIN RELIEF	532 1
J10C	66103-2	PIN CONTACT	532 1
J10D	66099-2	PIN CONTACT	532 1
J11A	206036-3	RECEPTACLE-WHEEL WELL ACCESS, RIGHT	632 1
J11B	206070-1	STRAIN RELIEF	632 1
J11C	66099-2	PIN CONTACT	632 1
J11D	66103-2	PIN CONTACT	632 1
J66A	1-480319-0	RECEPTACLE-TAIL POSITION LIGHT	310 1
J66B	60618-1	PIN CONTACT	310 1
J77A	1-480351-0	RECEPTACLE-LEFT WING NAVIGATION LIGHT	550 1
J77B	60618-1	PIN CONTACT	550 1
J78A	1-480351-0	RECEPTACLE-RIGHT WING NAVIGATION LIGHT	650 1
J78B	60618-1	PIN CONTACT	650 1
J85A	1-480288-0	RECEPTACLE-CROSSOVER DISCONNECT	251 1
J85B	60618-1	PIN CONTACT	251 1
P10A	206037-1	PLUG-LEFT WHEEL WELL ACCESS	532 1
P10B	66101-2	SOCKET CONTACT	532 1
P10C	66105-2	SOCKET CONTACT	532 1
P10D	206070-1	STRAIN RELIEF CLAMP	532 1
P11A	206037-1	PLUG-WHEEL WELL ACCESS, RIGHT	632 1
P11B	206070-1	STRAIN RELIEF	632 1
P11C	66101-2	SOCKET CONTACT	632 1
P11D	66105-2	SOCKET CONTACT	632 1
P66A	1-480318-0	PLUG-TAIL POSITION LIGHT	310 1
P66B	60617-1	SOCKET CONTACT	310 1
P77A	1-480349-0	PLUG-LEFT WING NAVIGATION LIGHT	550 1
P77B	60617-1	SOCKET CONTACT	550 1
P78A	1-480349-0	PLUG-RIGHT WING NAVIGATION LIGHT	650 1
P78B	60617-1	SOCKET CONTACT	650 1
P85A	1-480287-0	PLUG-CROSSOVER DISCONNECT	251 1
P85B	66017-1	SOCKET CONTACT	251 1
W12	114931-1-6	BUS LIGHT	240 1
XDS23	A1815A-6-7512	LAMPHOLDER-RIGHT WING NAVIGATION LIGHT	650 1
XDS25	A1815A-R-7512	LAMPHOLDER-LEFT WING NAVIGATION LIGHT	550 1

EFFECTIVITY CODE

1. CE-1665 AND AFTER; CJ-180 AND AFTER

Beechcraft
BONANZA
WIRING DIAGRAM MANUAL

33-46-01

**E-1111, E-1241 THRU E-1945, E-1947 THRU E-2103, E-2105 THRU
E-2110; CE-748, CE-772 AND AFTER; CJ-149 AND AFTER; D-10097,
D-10120 AND AFTER; EA-1 THRU EA-319, EA-321 THRU EA-388**

Beechcraft
BONANZA
WIRING DIAGRAM MANUAL

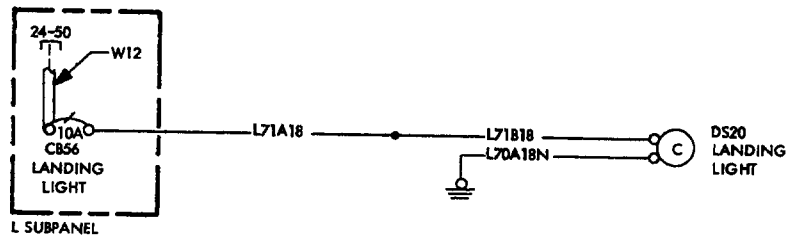

LIGHTS-LANDING

Beechcraft
BONANZA
WIRING DIAGRAM MANUAL

REFERENCE DESIGNATOR	PART NUMBER	DESCRIPTION	USABLE	
			INSTL ZONE	ON CODE
33-46-01				
CB56	35-380132-43	CIRCUIT BREAKER-LANDING LIGHT	240	1
DS20	4596	LIGHT-LANDING	410	1
W12	114931-1-6	BUS LIGHT	240	1

EFFECTIVITY CODE

1. E-1111, E-1241 THRU E-1945, E-1947 THRU E-2103, E-2105 THRU E-2110; CE-748, CE-772 AND AFTER; CJ-149 AND AFTER; D-10097, D-10120 AND AFTER; EA-1 THRU EA-319, EA-321 THRU EA-388

CHAPTER

34

NAVIGATION

Beechcraft
BONANZA
WIRING DIAGRAM MANUAL
LIST OF PAGES & TABLE OF CONTENTS
for
CHAPTER 34 - NAVIGATION & PITOT/STATIC

SYS/SUB-SYS/ CHAP SECTION	PAGE NO.	EFFECTIVE DATE	TABLE OF CONTENTS
34-20-01	Page 1	OCT/95	ATTITUDE AND DIRECTION-TURN COORDINATOR
	Page 2	OCT/95	
	Page 3	OCT/95	
34-22-01	Page 1	OCT/95	ATTITUDE AND DIRECTION-STANDBY AIR PUMP GYRO
	Page 2	OCT/95	
	Page 3	OCT/95	

Beechcraft
BONANZA
WIRING DIAGRAM MANUAL

34-20-01

**E-1111, E-1241 THRU E-1945, E-1947 THRU E-2103, E-2105 THRU
E-2110; CE-748, CE-772 AND AFTER; CJ-149 AND AFTER; D-10097,
D-10120 AND AFTER; EA-1 THRU EA-319, EA-321 THRU EA-388**

Beechcraft
BONANZA
WIRING DIAGRAM MANUAL

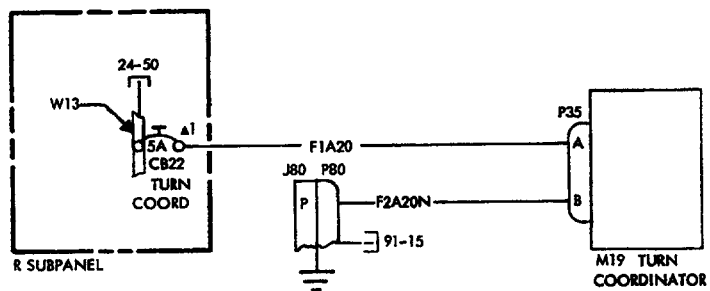

ATTITUDE AND DIRECTION-TURN COORDINATOR

Beechcraft
BONANZA
WIRING DIAGRAM MANUAL

REFERENCE DESIGNATOR	PART NUMBER	DESCRIPTION	USABLE	
			INSTL	ON ZONE CODE
34-20-01				
CB22	435-205-104	CIRCUIT BREAKER-TURN COORDINATOR	240	2
CB22	7277-2-5	CIRCUIT BREAKER-TURN COORDINATOR	240	3
J80	204814-1	RECEPTACLE-GROUNDING BLOCK	231	1
M19	58-380085-3	INDICATOR-TURN COORDINATOR (SPARES REPLACEMENT FOR 601-009-980)	240	1
P35	132325 10SL-3S	PLUG-TURN COORDINATOR	240	1
P80A	200838-3	PLUG-GROUNDING BLOCK	231	1
P80B	201224-1	STRAIN RELIEF	231	1
P80C	201328-1	SOCKET CONTACT	231	1
P80D	200333-1	SOCKET CONTACT	231	1
P80E	203618-1	JACKSCREW	231	1

EFFECTIVITY CODE

1. E-1111, E-1241 THRU E-1945, E-1947 THRU E-2103, E-2105 THRU E-2110; CE-748, CE-772 AND AFTER; CJ-149 AND AFTER; D-10097, D-10120 AND AFTER; EA-1 THRU EA-319, EA-321 THRU EA-388
2. E-1111, E-1241 THRU E-1765; CE-748, CE-772 THRU CE-918, CE-920 THRU CE-918; CJ-149 THRU CJ-155; D-10097, D-10120 THRU D-10347, D-10349 THRU D-10353; EA-1 THRU EA-158
3. E-1766 THRU E-1945, E-1947 THRU E-2103, E-2105 THRU E-2110; CE-919, CE-929 AND AFTER; CJ-156 AND AFTER; D-10348, D-10354 AND AFTER; EA-159 THRU EA-319, EA-321 THRU EA-388

Beechcraft
BONANZA
WIRING DIAGRAM MANUAL

34-22-01

CE-1056 AND AFTER; CJ-156 AND AFTER; D-10404 AND AFTER

Beechcraft BONANZA WIRING DIAGRAM MANUAL

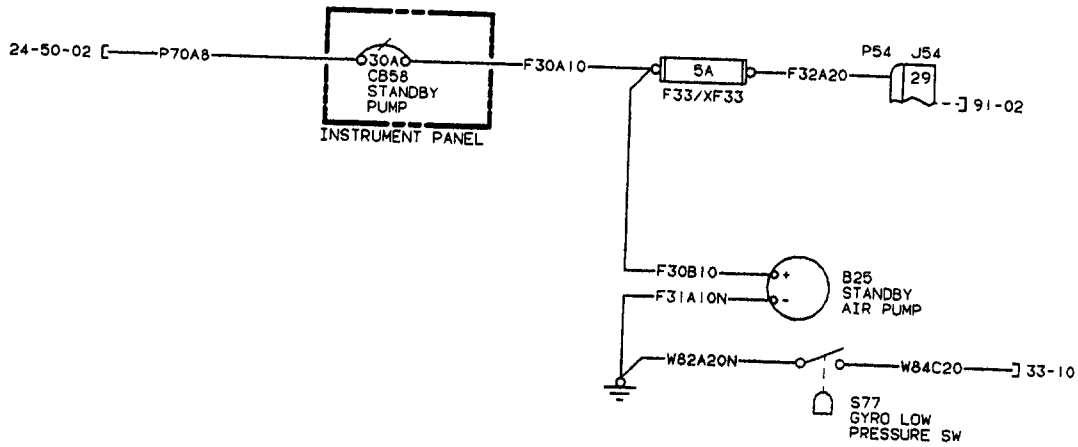

ATTITUDE AND DIRECTION-STANDBY AIR PUMP GYRO

Beechcraft
BONANZA
WIRING DIAGRAM MANUAL

REFERENCE DESIGNATOR	PART NUMBER	DESCRIPTION	USABLE	
			INSTL	ON ZONE CODE
34-22-01				
B25	EM917-2	MOTOR STANDBY AIR PUMP	410	1
CB58	35-380132-39	CIRCUIT BREAKER-STANDBY AIR PUMP	240	1
F33	AGC-5	FUSE-STANDBY AIR PUMP	222	1
J54A	206151-2	RECEPTACLE-JUNCTION BOX ASSEMBLY	231	1
J54B	206138-1	STRAIN RELIEF	231	1
J54C	66103-2	PIN CONTACT	231	1
P54A	206150-1	PLUG-JUNCTION BOX ASSEMBLY	231	1
P54B	206138-1	STRAIN RELIEF	231	1
P54C	66105-2	SOCKET CONTACT	231	1
S77	25530-1.5	SWITCH-GYRO LOW PRESSURE	410	3
S77	36-324096-19	SWITCH-GYRO LOW PRESSURE	410	4
S77	M4007-1.5	SWITCH-GYRO LOW PRESSURE	410	2
XF33	4522	FUSEHOLDER-STANDBY AIR PUMP	222	1

EFFECTIVITY CODE

1. CE-1056 AND AFTER; CJ-156 AND AFTER; D-10404 AND AFTER
2. CE-1056 THRU CE-1128; CJ-156 THRU CJ-178; D-10404 AND AFTER
3. CE-1129 THRU CE-1517; CJ-179 ONLY
4. CE-1518 AND AFTER; CJ-180 AND AFTER

CHAPTER

36

PNEUMATIC

Beechcraft
BONANZA
WIRING DIAGRAM MANUAL
LIST OF PAGES & TABLE OF CONTENTS
for
CHAPTER 36 - PNEUMATIC

SYS/SUB-SYS/ CHAP SECTION	PAGE NO.	EFFECTIVE DATE	TABLE OF CONTENTS
36-20-02 (Config 1)	Page 1	OCT/95	INDICATING-STANDBY INSTRUMENT AIR PRESSURE KIT (36-5009-3P)
	Page 2	OCT/95	
	Page 3	OCT/95	
36-20-02 (Config 2)	Page 1	OCT/95	INDICATING-STANDBY INSTRUMENT AIR PRESSURE KIT (36-5011-3P)
	Page 2	OCT/95	
	Page 3	OCT/95	

Beechcraft
BONANZA
WIRING DIAGRAM MANUAL

36-20-02

Configuration 1

**E-1111, E-1241 THRU E-1945, E-1947 THRU E-2103, E-2105 THRU
E-2110; CE-748, CE-772 THRU CE-1055; CJ-149 THRU CJ-155;
D-10097, D-10120 THRU D-10403 (AFTER INSTALLATION OF KIT
36-5009-3P PER SERVICE BULLETIN 2133)**

Beechcraft BONANZA WIRING DIAGRAM MANUAL

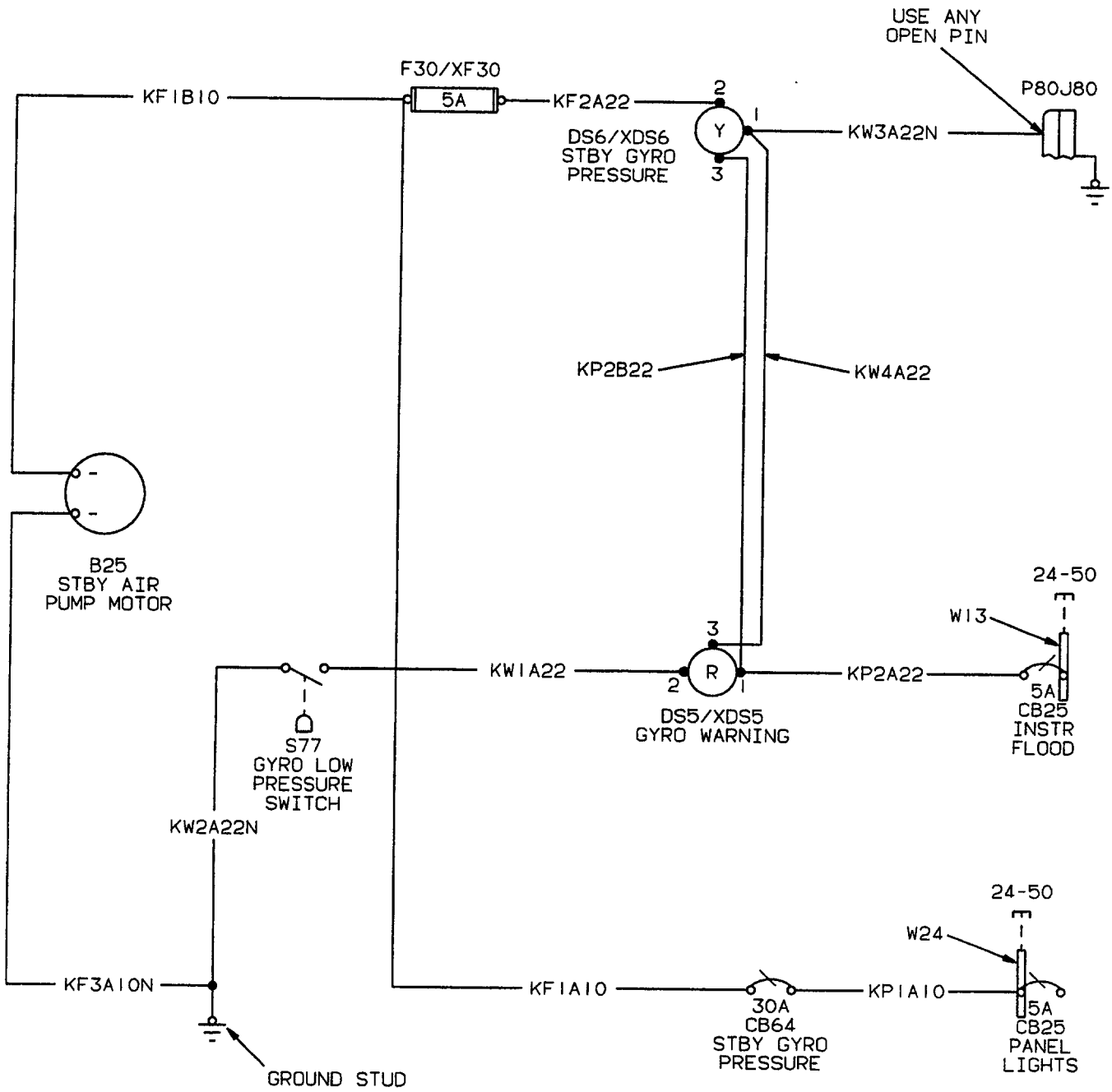

C95CE36F2865 C

INDICATING-STANDBY INSTRUMENT AIR PRESSURE KIT (36-5009-3P)
(Configuration 1)

Deechcraft
BONANZA
WIRING DIAGRAM MANUAL

REFERENCE DESIGNATOR	PART NUMBER	DESCRIPTION	USABLE	
			INSTL	ON ZONE CODE
36-20-02 (Configuration 1)				
	36-5009-3P	KIT-STANDBY INSTRUMENT AIR PRESSURE SYSTEM (TO INSTALL A STANDBY AIR PRESSURE SYSTEM ON IN SERVICE F33A, F33C, V35B AND A36 AIRPLANES PER SERVICE BULLETIN 2133)		1
B25	EM917-5	MOTOR-STANDBY AIR PUMP	410	1
CB25	435-205-104	CIRCUIT BREAKER-PANEL LIGHTS (USE EXISTING CIRCUIT BREAKER)	240	2
CB25	7277-2-5	CIRCUIT BREAKER-PANEL LIGHTS (USE EXISTING CIRCUIT BREAKER)	240	3
CB64	35-380132-39	CIRCUIT BREAKER-STANDBY GYRO PUMP	240	1
DS5	MS25237-327	LAMP	240	1
DS6	MS25237-327	LAMP	240	1
F30	AGC-5	FUSE	222	1
J80	204814-1	RECEPTACLE-GROUND BLOCK (USE EXISTING RECEPTACLE)	231	1
P80A	200838-3	PLUG-GROUNDING BLOCK (USE EXISTING PLUG)	231	1
P80B	201224-1	STRAIN RELIEF	231	1
P80C	201328-1	SOCKET CONTACT	231	1
P80D	200333-1	SOCKET CONTACT	231	1
P80E	203618-1	JACKSCREW	231	1
S77	M4007-1.5	SWITCH-GYRO LOW PRESSURE (USE 25530-1.5 AS SPARES REPLACEMENT)	240	1
W13	114931-1-12	BUS BAR (USE EXISTING BUS)	240	1
W24	36-364001-13	BUS BAR-START RELAY	222	1
XDS5	MS25041-6	LIGHT-GYRO WARNING INDICATOR	240	1
XDS6	MS25041-4	LIGHT-STANDBY GYRO PRESSURE INDICATOR	240	1
XF30	4522	FUSEHOLDER	222	1

EFFECTIVITY CODE

1. E-1111, E-1241 THRU E-1945, E-1947 THRU E-2103, E-2105 THRU E-2110; CE-748, CE-772 THRU CE-1055; CJ-149 THRU CJ-155; D-10097, D-10120 THRU D-10403 (AFTER INSTALLATION OF KIT 36-5009-3P PER SERVICE BULLETIN 2133)
2. E-1111, E-1241 THRU E-1765; CE-748, CE-772 THRU CE-918, CE-920 THRU CE-928; CJ-149 THRU CJ-155; D-10097, D-10120 THRU D-10347, D-10349 THRU D-10353 (AFTER INSTALLATION OF KIT 36-5009-3P PER SERVICE BULLETIN 2133)
3. E-1766 THRU E-1945, E-1947 THRU E-2103, E-2105 THRU E-2110; CE-919, CE-929 THRU CE-1055; D-10348, D-10354 THRU D-10403 (AFTER INSTALLATION OF KIT 36-5009-3P PER SERVICE BULLETIN 2133)

Beechcraft
BONANZA
WIRING DIAGRAM MANUAL

36-20-02

Configuration 2

**EA-1 THRU EA-319, EA-321 THRU EA-388 (AFTER INSTALLATION OF
KIT 36-9011-3P PER SERVICE BULLETIN 2133)**

Beechcraft BONANZA WIRING DIAGRAM MANUAL

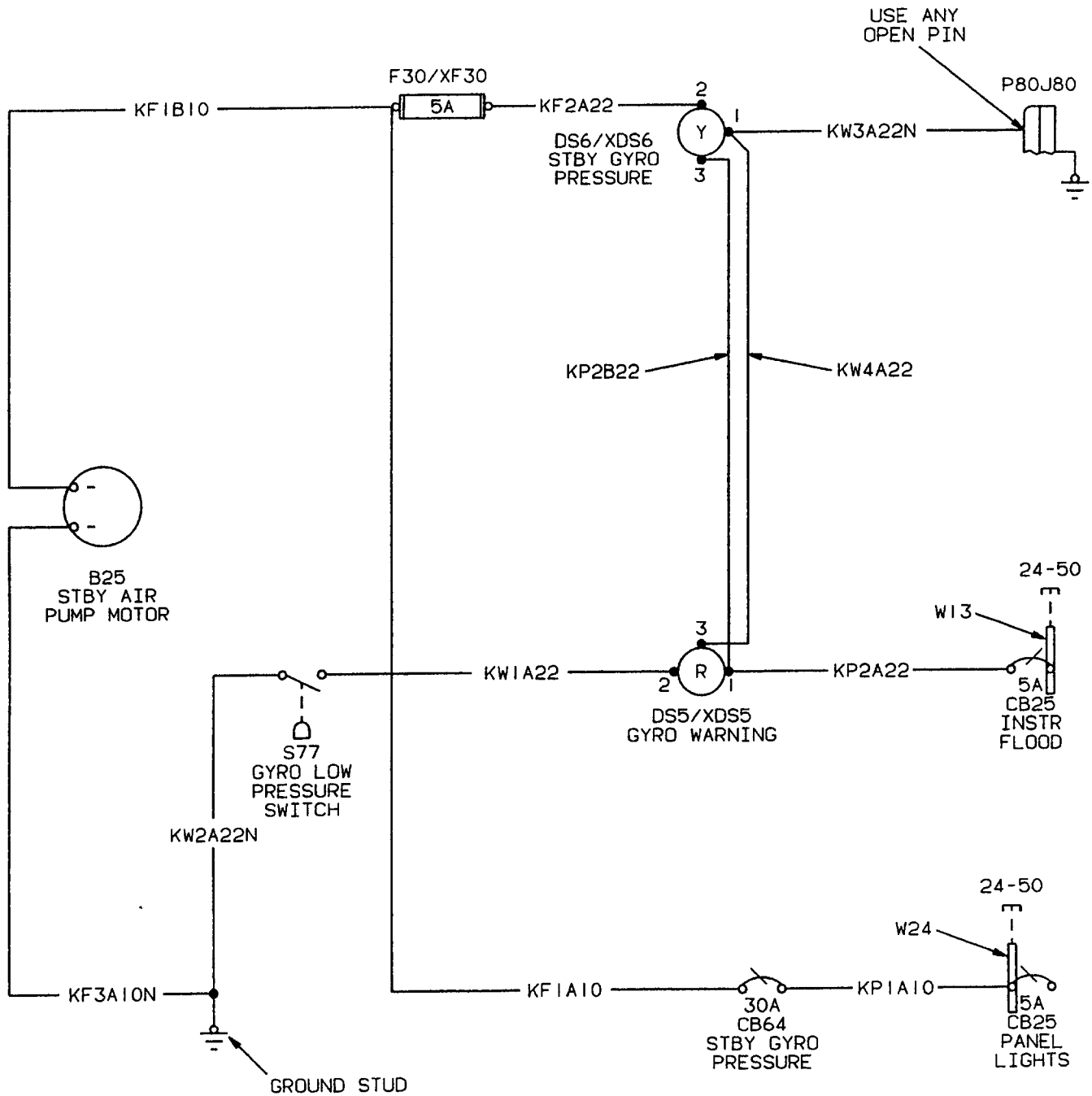

C95CE36F2865 C

INDICATING-STANDBY INSTRUMENT AIR PRESSURE KIT (36-5011-3P)
(Configuration 2)

Beechcraft
BONANZA
WIRING DIAGRAM MANUAL

REFERENCE DESIGNATOR	PART NUMBER	DESCRIPTION	USABLE INSTL ON ZONE CODE
36-20-02 (Configuration 2)			
	36-5011-3P	KIT-STANDBY AIR PRESSURE SYSTEM (TO INSTALL A STANDBY AIR PRESSURE SYSTEM ON IN SERVICE A36TC AND B36TC AIRPLANES PER SERVICE BULLETIN 2133)	1
B25	EM917-5	MOTOR-STANDBY AIR PUMP	410 1
CB25	435-205-104	CIRCUIT BREAKER-PANEL LIGHTS (USE EXISTING CIRCUIT BREAKER)	240 2
CB25	7277-2-5	CIRCUIT BREAKER-PANEL LIGHTS (USE EXISTING CIRCUIT BREAKER)	240 3
CB64	35-380132-39	CIRCUIT BREAKER-STANDBY GYRO PUMP	240 1
DS5	MS25237-327	LAMP	240 1
DS6	MS25237-327	LAMP	240 1
F30	AGC-5	FUSE	222 1
J80	204814-1	RECEPTACLE-GROUND BLOCK (USE EXISTING RECEPTACLE)	231 1
P80A	200838-3	PLUG-GROUNDING BLOCK (USE EXISTING PLUG)	231 1
P80B	201224-1	STRAIN RELIEF	231 1
P80C	201328-1	SOCKET CONTACT	231 1
P80D	200333-1	SOCKET CONTACT	231 1
P80E	203618-1	JACKSCREW	231 1
S77	M4007-1.5	SWITCH-GYRO LOW PRESSURE (USE 25530-1.5 AS SPARES REPLACEMENT)	240 1
W13	114931-1-12	BUS BAR (USE EXISTING BUS)	240 1
W24	36-364001-13	BUS BAR-START RELAY	222 1
XDS5	MS25041-6	LIGHT-GYRO WARNING INDICATOR	240 1
XDS6	MS25041-4	LIGHT-STANDBY GYRO PRESSURE INDICATOR	240 1
XF30	4522	FUSEHOLDER	222 1

EFFECTIVITY CODE

1. EA-1 THRU EA-319, EA-321 THRU EA-388 (AFTER INSTALLATION OF KIT 36-5011-3P PER SERVICE BULLETIN 2133)
2. EA-1 THRU EA-158 (AFTER INSTALLATION OF KIT 36-5011-3P PER SERVICE BULLETIN 2133)
3. EA-159 THRU EA-319, EA-321 THRU EA-388 (AFTER INSTALLATION OF KIT 36-5011-3P PER SERVICE BULLETIN 2133)

CHAPTER

39

Raytheon Aircraft

BEECH BONANZA WIRING DIAGRAM MANUAL

LIST OF PAGES & TABLE OF CONTENTS for CHAPTER 39 - ELECTRIC PANELS, PARTS & INSTRUMENTS

SYS/SUB-SYS/ CHAP SECTION	PAGE NO.	EFFECTIVE DATE	TABLE OF CONTENTS
39-10-01	Page 1 Page 2 Page 3	Oct/95 Oct/95 01/29/99	PRINTED CIRCUIT BOARD ASSEMBLY - ANNUNCIATOR LIGHT (E-1766 THRU E-1945, E-1947 THRU E-2103, E-2105 THRU E-2110; CE-919, CE-923, CE-925, CE-927, CE-929 THRU CE-1055; D-10354 THRU D-10403; EA-159 THRU EA-319, EA-321 THRU EA-388)
39-10-02	Page 1 Page 2 Page 3	Oct/95 Oct/95 01/29/99	PRINTED CIRCUIT BOARD ASSEMBLY - ANNUNCIATOR LIGHT (CE-1056 THRU CE-1300, CE-1302 THRU CE-1306; CJ-156 THRU CJ-179)
39-10-03	Page 1 Page 2 Page 3 Page 4 Page 5	01/29/99 01/29/99 01/29/99 01/29/99 01/29/99	PRINTED CIRCUIT BOARD ASSEMBLY - ANNUNCIATOR LIGHT (CE-1301, CE-1307 AND AFTER; CJ-180 AND AFTER)
39-10-10	Page 1 Page 2 Page 3	Oct/95 Oct/95 01/29/99	PRINTED CIRCUIT BOARD ASSEMBLY - LEFT FUEL QUANTITY INDICATOR (E-1111, E-1241 THRU E-1835; CE-748, CE-772 THRU CE-946; CJ-149 THRU CJ-155; D-10097, D-10120 THRU D-10369; EA-1 THRU EA-212)
39-10-20	Page 1 Page 2 Page 3	Oct/95 Oct/95 01/29/99	PRINTED CIRCUIT BOARD ASSEMBLY - FLAP POSITION (E-1111, E-1241 THRU E-1765; CE-748, CE-772 THRU CE-918, CE-920 THRU CE-922, CE-924, CE-926, CE-928; CJ-149 THRU CJ-155; D-10097, D-10120 THRU D-10353; EA-1 THRU EA-158)
39-10-30	Page 1 Page 2 Page 3	Oct/95 Oct/95 01/29/99	PRINTED CIRCUIT BOARD ASSEMBLY - ELECTRICAL EQUIPMENT (E-1111, E-1241 THRU E-1765; CE-748, CE-772 THRU CE-918, CE-920 THRU CE-922, CE-924, CE-926, CE-928; CJ-149 THRU CJ-155; D-10097, D-10120 THRU D-10353; EA-1 THRU EA-158)
39-10-40	Page 1 Page 2 Page 3 Page 4 Page 5	01/29/99 01/29/99 01/29/99 01/29/99 01/29/99	PRINTED CIRCUIT BOARD ASSEMBLY - FUEL QUANTITY INDICATOR (E-1836 THRU E-1945, E-1947 THRU E-2103, E-2105 THRU E-2110; CE-947 THRU CE-1009; CJ-156 AND AFTER; D-10370 AND AFTER; EA-213 THRU EA-319, EA-321 THRU EA-388)
39-10-41	Page 1 Page 2 Page 3	01/29/99 01/29/99 01/29/99	PRINTED CIRCUIT BOARD ASSEMBLY - FUEL QUANTITY INDICATOR (CE-1010 AND AFTER)

Beechcraft
BONANZA
WIRING DIAGRAM MANUAL

39-10-01

**E-1766 THRU E-1945, E-1947 THRU E-2103, E-2105 THRU E-2110;
CE-919, CE-923, CE-925, CE-927, CE-929 THRU CE-1055; D-10354
THRU D-10403; EA-159 THRU EA-319, EA-321 THRU EA-388**

Beechcraft
 BONANZA
 WIRING DIAGRAM MANUAL

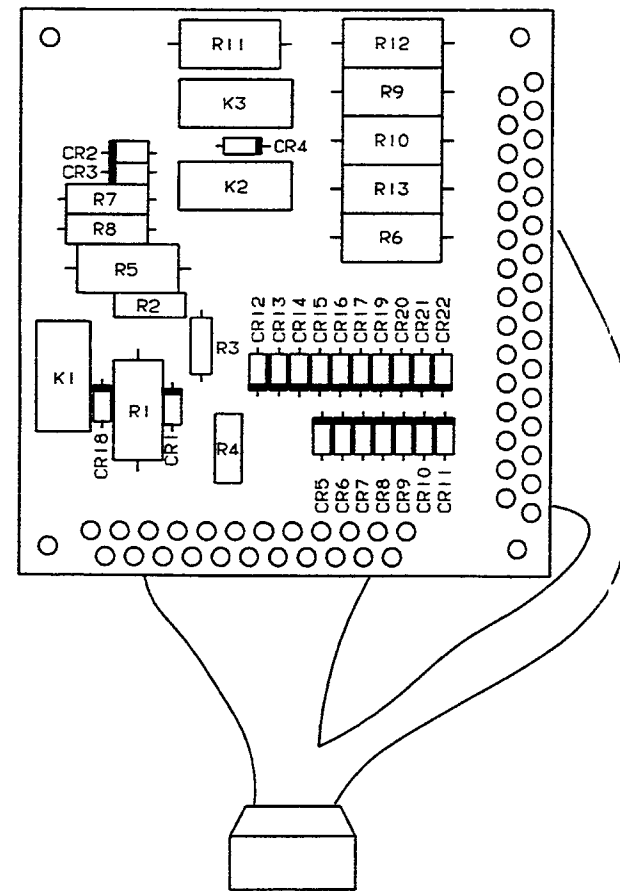
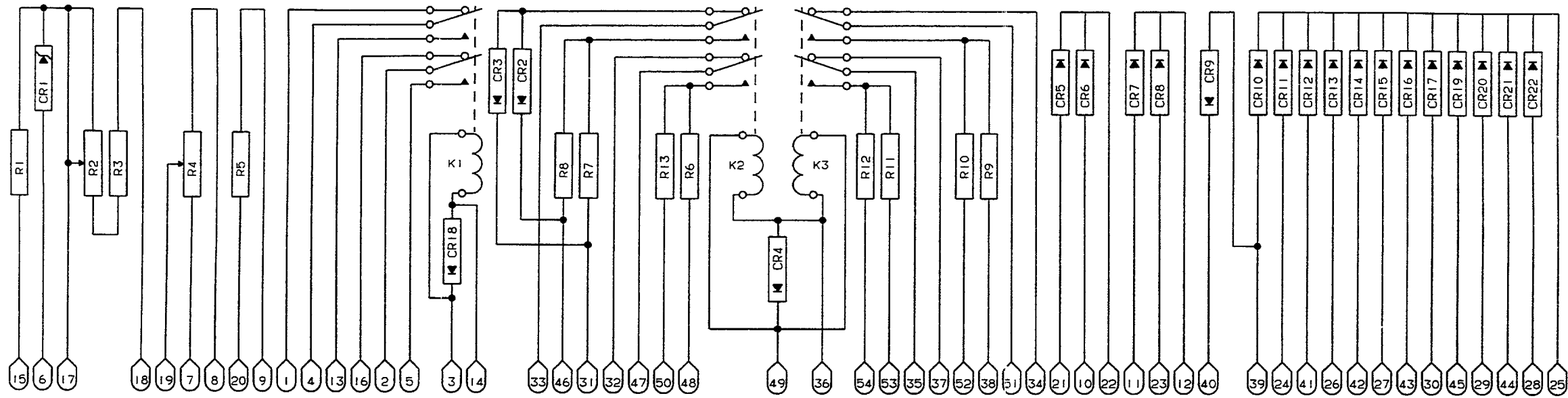

PRINTED CIRCUIT BOARD ASSEMBLY-ANNUNCIATOR LIGHT
 (58-364055-1)

Raytheon Aircraft

BEECH BONANZA WIRING DIAGRAM MANUAL

REFERENCE DESIGNATOR	PART NUMBER	DESCRIPTION	INSTL ZONE	USABLE ON CODE
39-10-01				
A10A1A1	58-364055-1	PRINTED CIRCUIT BOARD ASSEMBLY-ANNUNCIATOR LIGHT	231	1
A10A1A1CR1	1N4734A	DIODE (ALTN FOR 1N4734) (SUPERSEDED BY 132409-31)	231	1
A10A1A1CR1	1N4734	DIODE (ALTN FOR 1N4734A) (SUPERSEDED BY 132409-31)	231	1
A10A1A1CR1	132409-31	DIODE (SUPERSEDES 1N4734 AND 1N4734A)	231	1
A10A1A1CR2	1N4007	DIODE (TYPICAL CR3, CR4, CR7 THRU CR16) (CR5, CR6 AND CR17 USED ON THE -7 ASSEMBLY, 39-10-02) (SUPERSEDED BY 132408-22)	231	1
A10A1A1CR2	132408-22	DIODE (TYPICAL CR3, CR4, CR7 THRU CR16) (CR5, CR6 AND CR17 USED ON THE -7 ASSEMBLY, 39-10-02) (SUPERSEDES 1N4007)	231	1
A10A1A1K2	50-384112-1	RELAY (TYPICAL K3)	231	1
A10A1A1R1	RCR42G361KS	RESISTOR (ALTN FOR RCR42G361JS)	231	1
A10A1A1R1	RCR42G361JS	RESISTOR (ALTN FOR RCR42G361KS) (SUPERSEDED BY 132371E3600EFA)	231	1
A10A1A1R1	132371E3600EFA	RESISTOR (SUPERSEDES RCR42G361JS)	231	1
A10A1A1R2	RT22CW202	RESISTOR	231	1
A10A1A1R3	RCR20G562KS	RESISTOR (ALTN FOR RCR20G562JS)	231	1
A10A1A1R3	RCR20G562JS	RESISTOR (ALTN FOR RCR20G562KS) (SUPERSEDED BY 132371C5601EBC)	231	1
A10A1A1R3	132371C5601EBC	RESISTOR (SUPERSEDES RCR20G562JS)	231	1
A10A1A1R6	RCR42G151JS	RESISTOR (ALTN FOR RCR42G151KS) (SUPERSEDED BY 132371E1500EFA)	231	1
A10A1A1R6	RCR42G151KS	RESISTOR (ALTN FOR RCR42G151JS)	231	1
A10A1A1R6	132371E1500EFA	RESISTOR (SUPERSEDES RCR42G151JS)	231	1
A10A1A1R7	RCR20G511KS	RESISTOR (ALTN FOR RCR20G511JS)	231	1
A10A1A1R7	RCR20G511JS	RESISTOR (ALTN FOR RCR20G511KS) (R9 AND R13 USED ON THE -7 ASSEMBLY, 39-10-02) (SUPERSEDED BY 132371C5100EBC)	231	1
A10A1A1R7	132371C5100EBC	RESISTOR (ALTN FOR RCR20G511KS) (R9 AND R13 USED ON THE -7 ASSEMBLY, 39-10-02) (SUPERSEDES RCR20G511JS)	231	1
A10A1A1W1	58-364054-1	PRINTED CIRCUIT BOARD (WITHOUT COMPONENTS)	231	1

CODES OF EFFECTIVITY

1. E-1766 THRU E-1945, E-1947 THRU E-2103, E-2105 THRU E-2110; CE-919, CE-923, CE-925, CE-927, CE-929 THRU CE-1055; D-10354 THRU D-10403; EA-159 THRU EA-319, EA-321 THRU EA-388

Beechcraft
BONANZA
WIRING DIAGRAM MANUAL

39-10-02

**CE-1056 THRU CE-1300, CE-1302 THRU CE-1306; CJ-156 THRU
CJ-179**

Beechcraft
BONANZA
WIRING DIAGRAM MANUAL

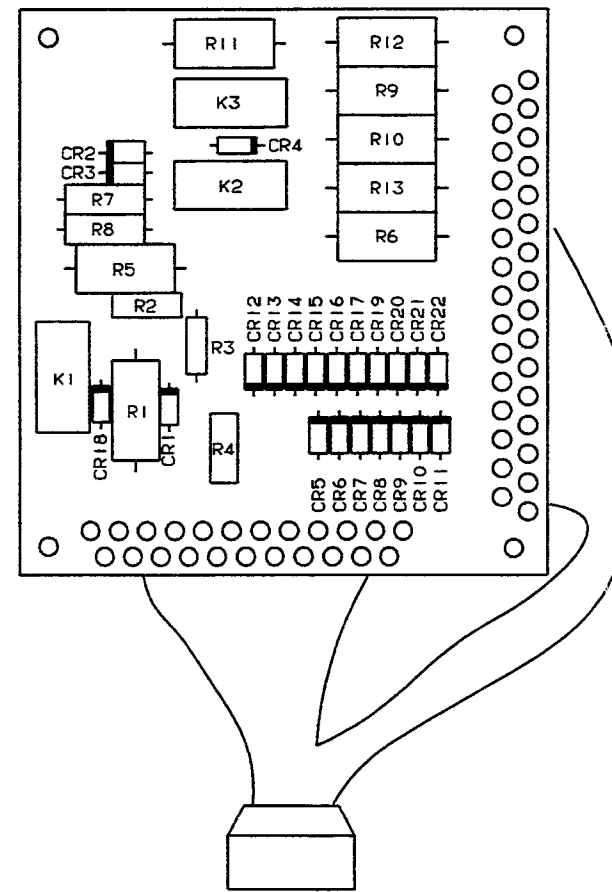
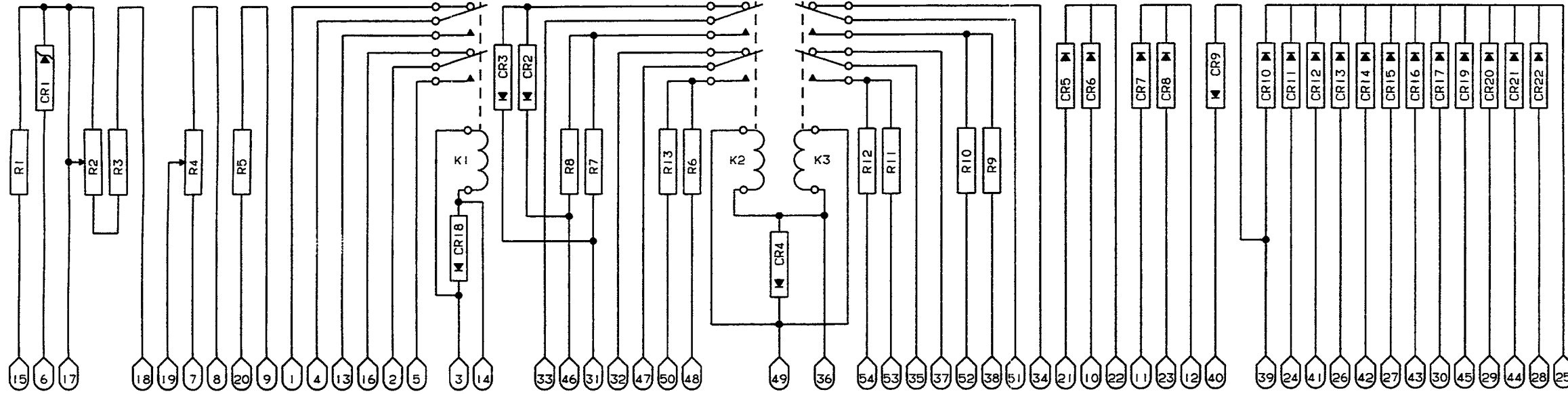

PRINTED CIRCUIT BOARD ASSEMBLY-ANNUNCIATOR LIGHT
(58-364055-7)

39-10-02
 PAGE 2
 OCT/95

C95CE39F2334 C

Raytheon Aircraft

BEECH BONANZA WIRING DIAGRAM MANUAL

REFERENCE DESIGNATOR	PART NUMBER	DESCRIPTION	INSTL ZONE	USABLE ON CODE
39-10-02				
A10A1A1	58-364055-7	PRINTED CIRCUIT BOARD ASSEMBLY-ANNUNCIATOR LIGHT	231	1
A10A1A1CR1	1N4734A	DIODE (ALTN FOR 1N4734) (SUPERSEDED BY 132409-31)	231	1
A10A1A1CR1	1N4734	DIODE (ALTN FOR 1N4734A) (SUPERSEDED BY 132409-31)	231	1
A10A1A1CR1	132409-31	DIODE (SUPERSEDES 1N4734 AND 1N4734A)	231	1
A10A1A1CR2	1N4007	DIODE (TYPICAL CR3 THRU CR17) (SUPERSEDED BY 132408-22)	231	1
A10A1A1CR2	132408-22	DIODE (TYPICAL CR3 THRU CR17) (SUPERSEDES 1N4007)	231	1
A10A1A1K2	50-384112-1	RELAY (TYPICAL K3)	231	1
A10A1A1R1	RCR42G361KS	RESISTOR (ALTN FOR RCR42G361JS)	231	1
A10A1A1R1	RCR42G361JS	RESISTOR (ALTN FOR RCR42G361KS) (SUPERSEDED BY 132371E3600EFA)	231	1
A10A1A1R1	132371E3600EFA	RESISTOR (ALTN FOR RCR42G361KS) (SUPERSEDES RCR42G361JS)	231	1
A10A1A1R2	RT22CW202	RESISTOR	231	1
A10A1A1R3	RCR20G562KS	RESISTOR (ALTN FOR RCR20G562JS)	231	1
A10A1A1R3	RCR20G562JS	RESISTOR (ALTN FOR RCR20G562KS) (SUPERSEDED BY 132371C5601EBC)	231	1
A10A1A1R3	132371C5601EBC	RESISTOR (SUPERSEDES RCR20G562JS)	231	1
A10A1A1R6	RCR42G151JS	RESISTOR (ALTN FOR RCR42G151KS) (SUPERSEDED BY 132371E1500EFA)	231	1
A10A1A1R6	RCR42G151KS	RESISTOR (ALTN FOR RCR42G151JS)	231	1
A10A1A1R6	132371E1500EFA	RESISTOR (SUPERSEDES RCR42G151JS)	231	1
A10A1A1R7	RCR20G511KS	RESISTOR (ALTN FOR RCR20G511JS)	231	1
A10A1A1R7	RCR20G511JS	RESISTOR (ALTN FOR RCR20G511KS) (TYPICAL R9 AND R13) (SUPERSEDED BY 132371C5100EBC)	231	1
A10A1A1R7	132371C5100EBC	RESISTOR (TYPICAL R9 AND R13) (SUPERSEDES RCR20G511JS)	231	1

CODES OF EFFECTIVITY

1. CE-1056 THRU CE-1300, CE-1302 THRU CE-1306; CJ-156 THRU CJ-179

39-10-03

**PRINTED CIRCUIT BOARD ASSEMBLY-ANNUNCIATOR LIGHT (58-
364055-9)**

CE-1301, CE-1307 AND AFTER; CJ-180 AND AFTER

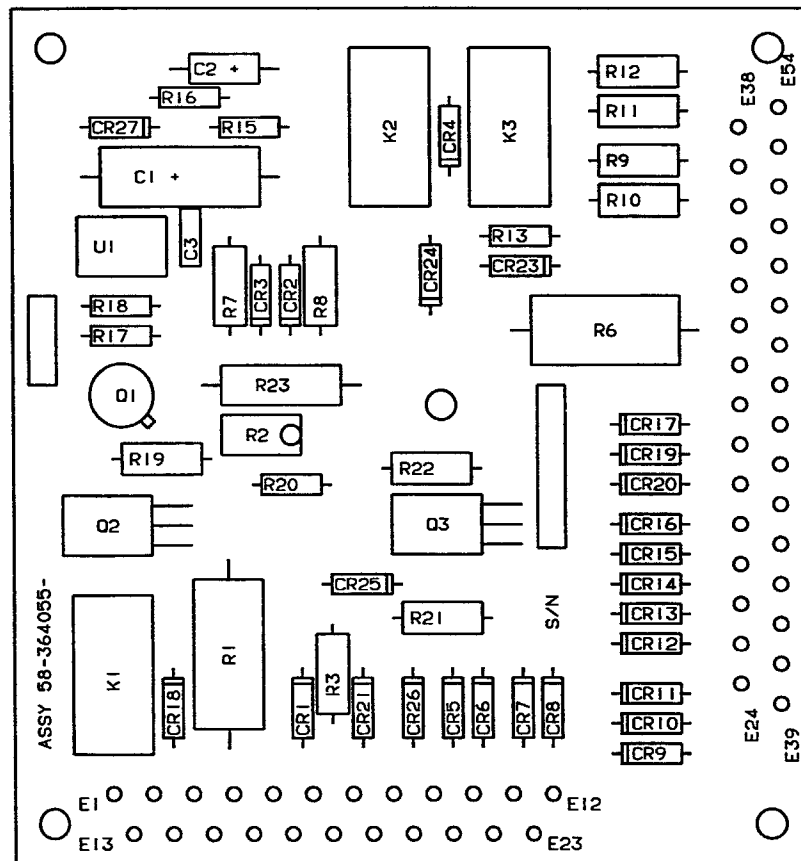
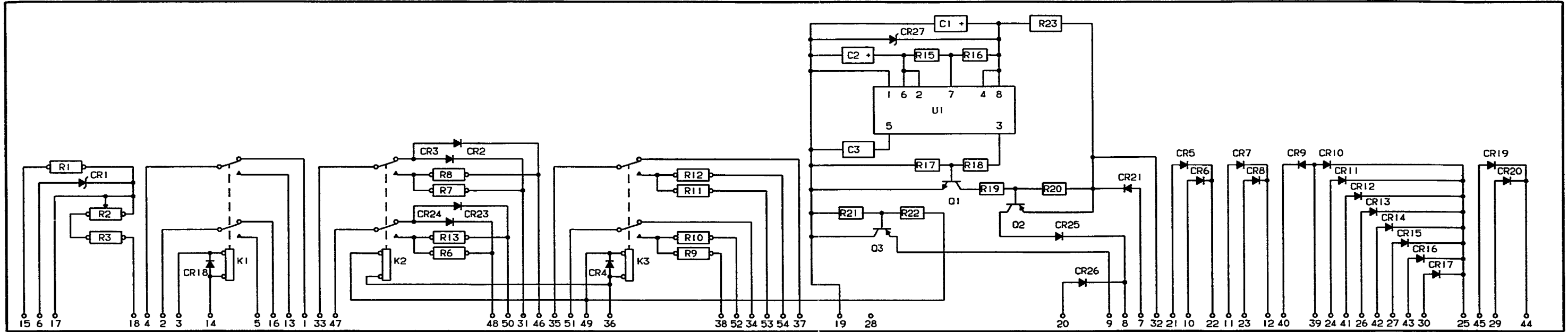

C95CE39F2336 C

PRINTED CIRCUIT BOARD ASSEMBLY-ANNUNCIATOR LIGHT (58-364055-9)
 CE-1301, CE-1307 AND AFTER; CJ-180 AND AFTER

Raytheon Aircraft

BEECH BONANZA WIRING DIAGRAM MANUAL

REFERENCE DESIGNATOR	PART NUMBER	DESCRIPTION	INSTL ZONE	USABLE ON CODE
39-10-03				
A10A1	58-364055-9	PRINTED CIRCUIT BOARD ASSEMBLY-ANNUNCIATOR LIGHT	131	1
A10A1CR1	1N4734A	DIODE (SUPERSEDED BY 132409-31)	131	1
A10A1CR1	132409-31	DIODE (SUPERSEDES 1N4734A)	131	1
A10A1CR2	1N4007	DIODE (TYPICAL CR3 THRU CR21 AND CR23 THRU CR26) (SUPERSEDED BY 132408-22)	131	1
A10A1CR2	132408-22	DIODE (TYPICAL CR3 THRU CR21 AND CR23 THRU CR26) (SUPERSEDES 1N4007)	131	1
A10A1CR27	1N4742A	DIODE (SUPERSEDED BY 132409-37)	131	1
A10A1CR27	132409-37	DIODE (SUPERSEDES 1N4742A)	131	1
A10A1C1	CSR13G106KM	CAPACITOR (SUPERSEDED BY 132391C10R00FNU)	131	1
A10A1C1	132391C10R00FNU	CAPACITOR (SUPERSEDES CSR13G106KM)	131	1
A10A1C2	CSR13G105KM	CAPACITOR (SUPERSEDED BY 132391A1R000FNU)	131	1
A10A1C2	132391A1R000FNU	CAPACITOR (SUPERSEDES CSR13G105KM)	131	1
A10A1C3	CKR05BX103KR	CAPACITOR (SUPERSEDED BY 132389C103EHM)	131	1
A10A1C3	132389C103EHM	CAPACITOR (SUPERSEDES CKR05BX103KM)	131	1
A10A1K1	50-384112-1	RELAY (TYPICAL K2 AND K3)	131	1
A10A1Q1	2N5681	TRANSISTOR (SUPERSEDED BY 132404-26)	131	1
A10A1Q1	132404-26	TRANSISTOR (SUPERSEDES 2N5681)	131	1
A10A1Q2	2N5195	TRANSISTOR (TYPICAL Q3) (SUPERSEDED BY 132404-21)	131	1
A10A1Q2	132404-21	TRANSISTOR (TYPICAL Q3) (SUPERSEDES 2N5195)	131	1
A10A1R1	RCR42G361JS	RESISTOR (SUPERSEDED BY 132371E3600EFA)	131	1
A10A1R1	132371E3600EFA	RESISTOR (SUPERSEDES RCR42G361JS)	131	1
A10A1R15	RNR60C5113FR	RESISTOR (SUPERSEDED BY 132373G5113DBB)	131	1
A10A1R15	132373G5113DBB	RESISTOR (SUPERSEDES RNR60C5113FR)	131	1
A10A1R16	RLR07C4701GS	RESISTOR (TYPICAL R17) (SUPERSEDED BY 132371B4701EBC)	131	1
A10A1R16	132371B4701EBC	RESISTOR (TYPICAL R17) (SUPERSEDES RLR07C4701GS)	131	1
A10A1R18	RLR07C1002GS	RESISTOR (SUPERSEDED BY 132371B1002EBC)	131	1
A10A1R18	132371B1002EBC	RESISTOR (SUPERSEDES RLR07C1002GS)	131	1
A10A1R19	RCR20G202JS	RESISTOR (SUPERSEDED BY 132371C2001EBC)	131	1
A10A1R19	132371C2001EBC	RESISTOR (SUPERSEDES RCR20G202JS)	131	1
A10A1R2	RT22C2W202	POTENTIOMETER	131	1
A10A1R20	RLR07C1001GS	RESISTOR (SUPERSEDED BY 132371B1001EBC)	131	1
A10A1R20	132371B1001EBC	RESISTOR (SUPERSEDES RLR07C1001GS)	131	1
A10A1R21	RCR20G471GS	RESISTOR (SUPERSEDED BY 132371C4700EBC)	131	1
A10A1R21	132371C4700EBC	RESISTOR (SUPERSEDES RCR20G471JS)	131	1
A10A1R23	4418	RESISTOR	131	1
A10A1R3	RCR20G562JS	RESISTOR (SUPERSEDED BY 132371C5601EBC)	131	1
A10A1R3	132371C5601EBC	RESISTOR (SUPERSEDES RCR20G562JS)	131	1
A10A1R6	RCR42G151JS	RESISTOR (SUPERSEDED BY 132371E1500EFA)	131	1
A10A1R6	132371E1500EFA	RESISTOR (SUPERSEDES RCR42G151JS)	131	1
A10A1R7	RCR20G511JS	RESISTOR (TYPICAL R8, R9, R11, R13) (SUPERSEDED BY 132371C5100EBC)	131	1
A10A1R7	132371C5100EBC	RESISTOR (TYPICAL R8, R9, R11, R13) (SUPERSEDES RCR20G511JS)	131	1
A10A1U1	LM555J	TIMER	131	1

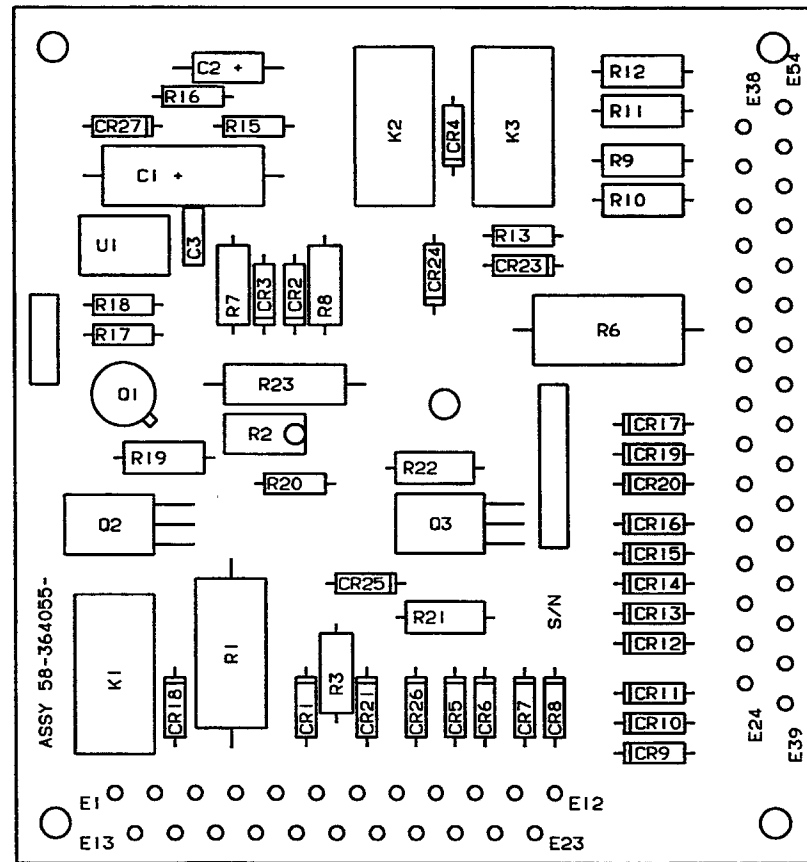
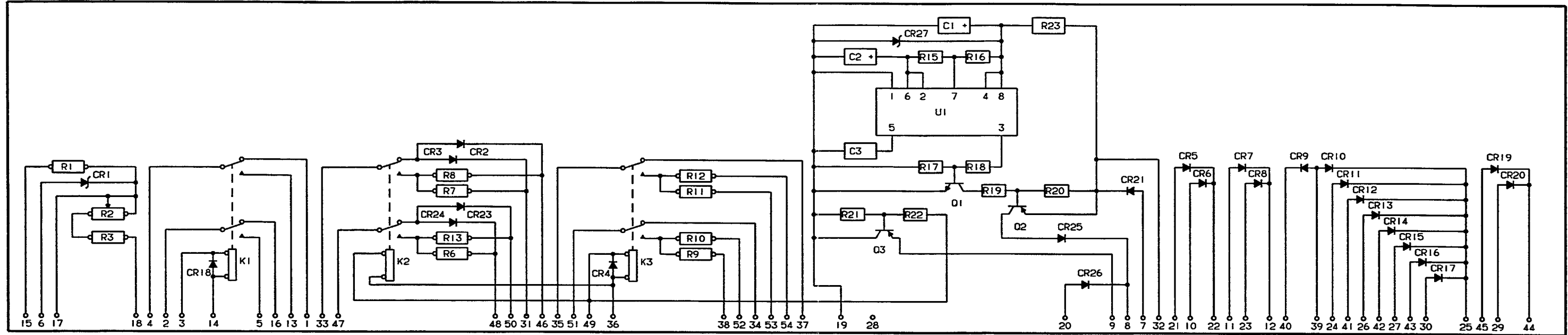

C95CE39F2336 C

PRINTED CIRCUIT BOARD ASSEMBLY-ANNUNCIATOR LIGHT (58-364055-9)
 CE-1301, CE-1307 AND AFTER; CJ-180 AND AFTER

Raytheon Aircraft

BEECH BONANZA WIRING DIAGRAM MANUAL

REFERENCE DESIGNATOR	PART NUMBER	DESCRIPTION	INSTL ZONE	USABLE ON CODE
39-10-03				
A10A1W1	58-364054-7	PRINTED CIRCUIT BOARD (WITHOUT COMPONENTS)	131	1

CODES OF EFFECTIVITY

1. CE-1301, CE-1307 AND AFTER; CJ-180 AND AFTER

Beechcraft
BONANZA
WIRING DIAGRAM MANUAL

39-10-10

**E-1111, E-1241 THRU E-1835; CE-748, CE-772 THRU CE-946; CJ-149
THRU CJ-155; D-10097, D-10120 THRU D-10369; EA-1 THRU EA-212**

Beechcraft BONANZA WIRING DIAGRAM MANUAL

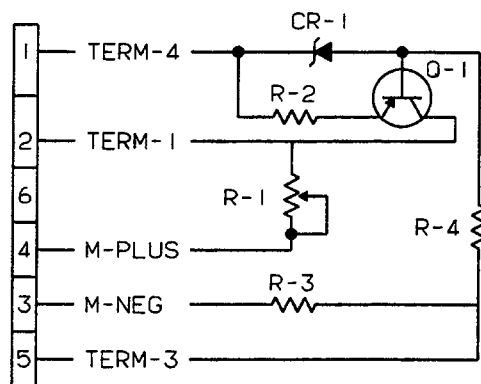
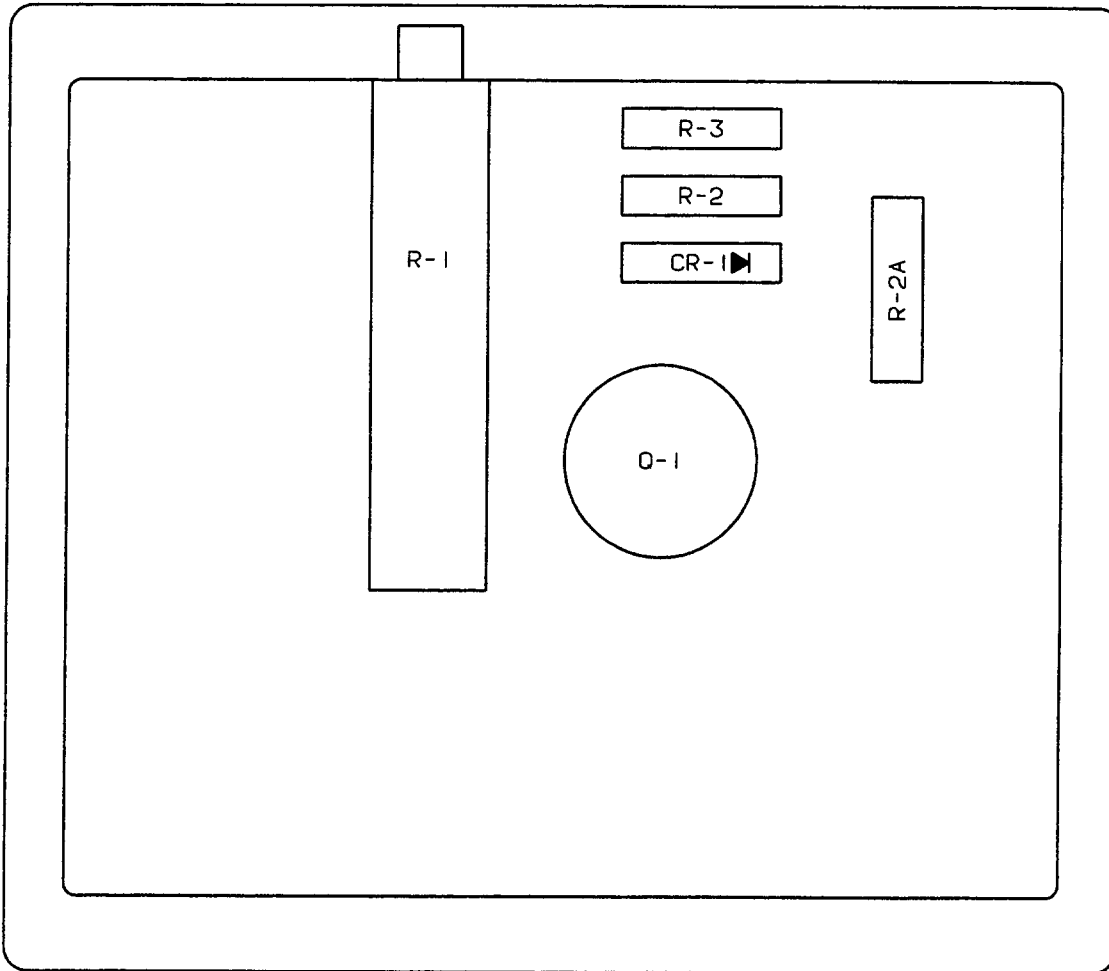

C96CE39F0016 C

**PRINTED CIRCUIT BOARD ASSEMBLY-LEFT FUEL QUANTITY INDICATOR
(58-364041-9)**

Raytheon Aircraft

BEECH BONANZA WIRING DIAGRAM MANUAL

REFERENCE DESIGNATOR	PART NUMBER	DESCRIPTION	INSTL ZONE	USABLE ON CODE
39-10-10				
A13/A14	58-364041-9	PRINTED CIRCUIT BOARD ASSEMBLY-LEFT FUEL QUANTITY INDICATOR (TYPICAL BREAKDOWN FOR THE A14 RIGHT FUEL QUANTITY INDICATOR PCB)	240	1
A13CR1	1N4734	ZENER DIODE (ALTN FOR 1N4734A) (SUPERSEDED BY 132409-31)	240	1
A13CR1	1N4734A	ZENER DIODE (ALTN FOR 1N4734) (SUPERSEDED BY 132409-31)	240	1
A13CR1	132409-31	ZENER DIODE (SUPERSEDES 1N4734 AND 1N4734A)	240	1
A13Q1	2N4036	TRANSISTOR (SUPERSEDED BY 132404-15)	240	1
A13Q1	132404-15	TRANSISTOR (SUPERSEDES 2N4036)	240	1
A13R1	3810P502	TRIM POT	240	1
A13R2	RC07GF471J	RESISTOR (TYPICAL R3) (SUPERSEDED BY 132371B4700EBC)	240	1
A13R2	132371B4700EBC	RESISTOR (TYPICAL R3) (SUPERSEDES RC07GF471J)	240	1
A13R4	RC07GF302J	RESISTOR (SUPERSEDED BY 132371B3001EBC)	240	1
A13R4	132371B3001EBC	RESISTOR (SUPERSEDES RC07GF302J)	240	1
A13W1	58-364041-5	PRINTED CIRCUIT BOARD (WITHOUT COMPONENTS)	240	1

CODES OF EFFECTIVITY

1. E-1111, E-1241 THRU E-1835; CE-748, CE-772 THRU CE-946; CJ-149 THRU CJ-155; D-10097, D-10120 THRU D-10369; EA-1 THRU EA-212

Beechcraft
BONANZA
WIRING DIAGRAM MANUAL

39-10-20

**E-1111, E-1241 THRU E-1765; CE-748, CE-772 THRU CE-918, CE-920
THRU CE-922, CE-924, CE-926, CE-928; CJ-149 THRU CJ-155;
D-10097, D-10120 THRU D-10353; EA-1 THRU EA-158**

Beechcraft
BONANZA
WIRING DIAGRAM MANUAL

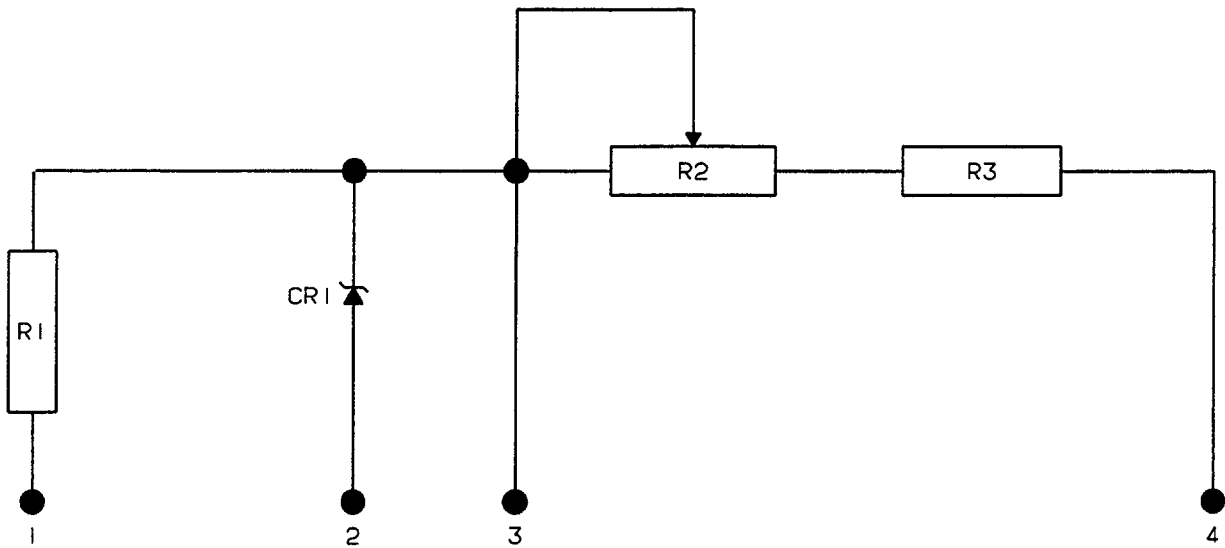
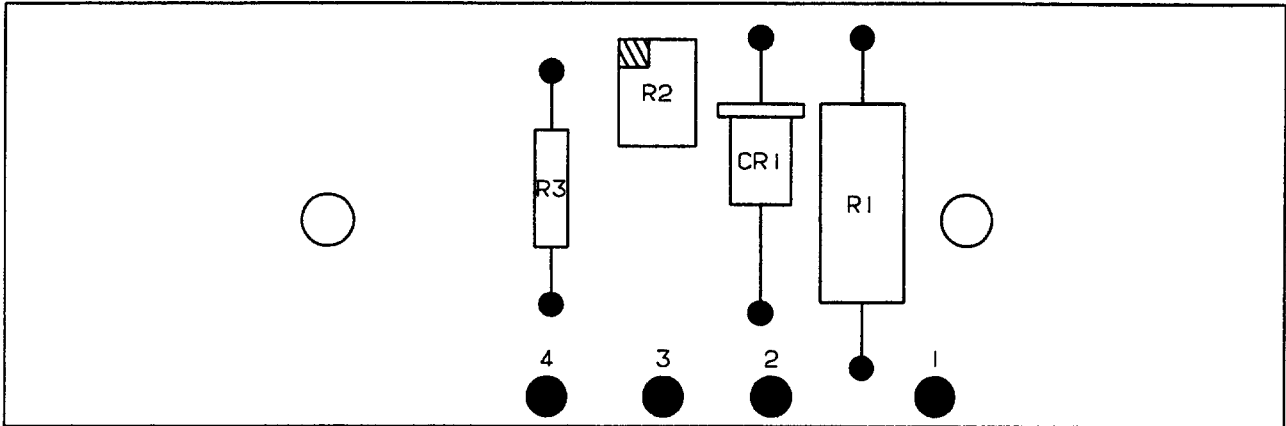

C96CE39F001B C

PRINTED CIRCUIT BOARD ASSEMBLY-FLAP POSITION
(002-364040-1)

Raytheon Aircraft

BEECH BONANZA WIRING DIAGRAM MANUAL

REFERENCE DESIGNATOR	PART NUMBER	DESCRIPTION	INSTL ZONE	USABLE ON CODE
39-10-20				
A19A1	002-364040-1	PRINTED CIRCUIT BOARD ASSEMBLY-FLAP POSITION	231	1
A19A1CR1	1N4734	ZENER DIODE (ALTN FOR 1N4734A) (SUPERSEDED BY 132409-31)	231	1
A19A1CR1	1N4734A	ZENER DIODE (ALTN FOR 1N4734) (SUPERSEDED BY 132409-31)	231	1
A19A1CR1	132409-31	ZENER DIODE (SUPERSEDES 1N4734 AND 1N4734A)	231	1
A19A1R1	RC42GF820J	RESISTOR	231	1
A19A1R2	205-208	POTENTIOMETER (ALTN FOR 552-00S)	231	1
A19A1R2	552-00S	POTENTIOMETER (ALTN FOR 205-208)	231	1
A19A1R3	RCR20G432JS	RESISTOR (ALTN FOR RCR20G432KS) (SUPERSEDED BY 132371C4301EBC)	231	1
A19A1R3	132371C4301EBC	RESISTOR (ALTN FOR RCR20G432KS) (SUPERSEDES RCR20G432JS)	231	1
A19A1W1	002-364041	PRINTED CIRCUIT BOARD (WITHOUT COMPONENTS)	231	1

CODES OF EFFECTIVITY

1. E-1111, E-1241 THRU E-1765; CE-748, CE-772 THRU CE-918, CE-920 THRU CE-922, CE-924, CE-926, CE-928; CJ-149 THRU CJ-155; D-10097, D-10120 THRU D-10353; EA-1 THRU EA-158

Beechcraft
BONANZA
WIRING DIAGRAM MANUAL

39-10-30

**E-1111, E-1241 THRU E-1765; CE-748, CE-772 THRU CE-918, CE-920
THRU CE-922, CE-924, CE-926, CE-928; CJ-149 THRU CJ-155;
D-10097, D-10120 THRU D-10353; EA-1 THRU EA-158**

Beechcraft BONANZA WIRING DIAGRAM MANUAL

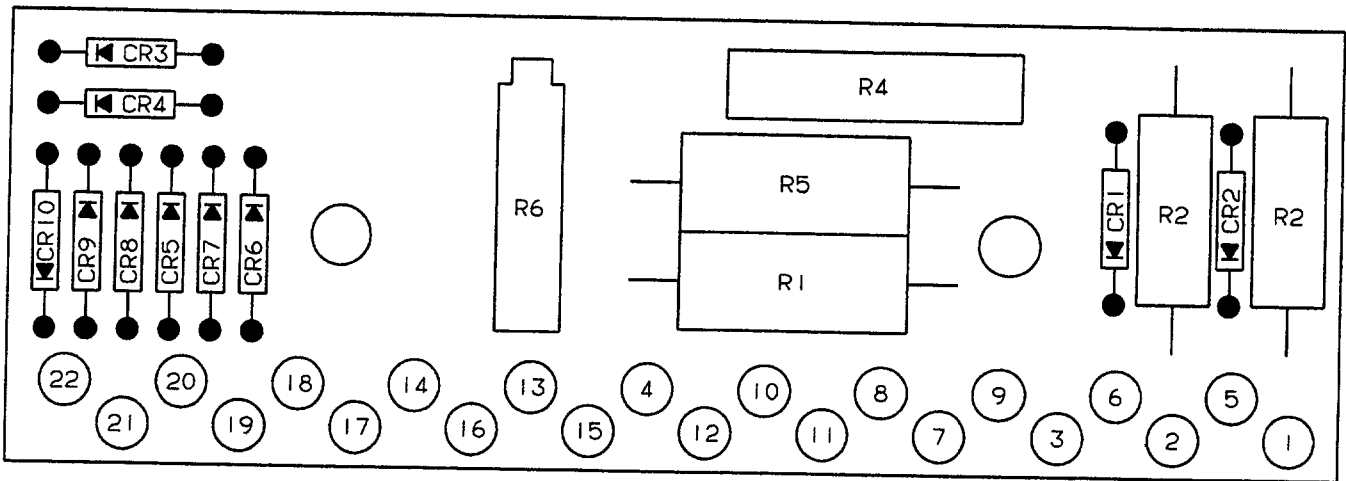
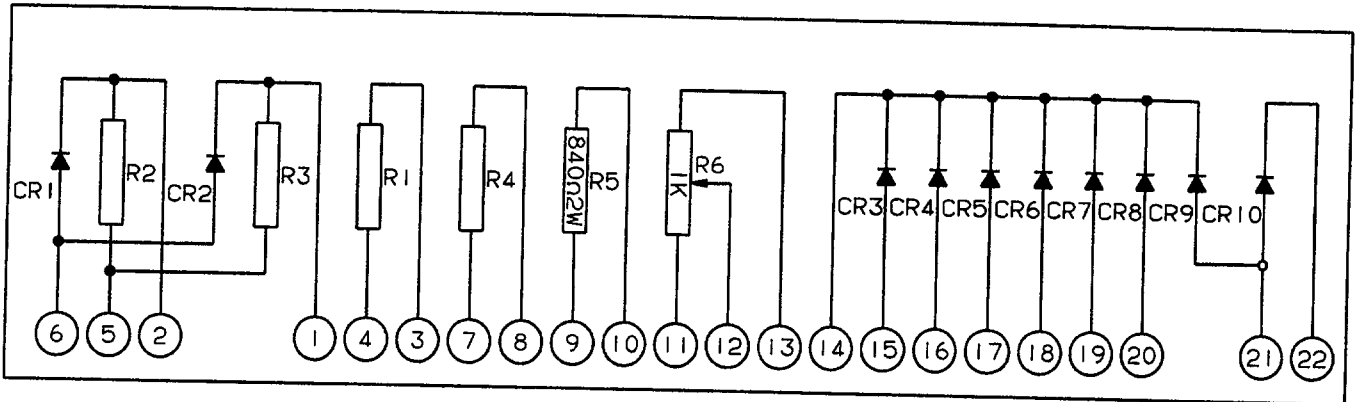

C96CE39F0017 C

PRINTED CIRCUIT BOARD ASSEMBLY-ELECTRICAL EQUIPMENT
(002-364038-1)

Raytheon Aircraft

BEECH BONANZA WIRING DIAGRAM MANUAL

REFERENCE DESIGNATOR	PART NUMBER	DESCRIPTION	INSTL ZONE	USABLE ON CODE
39-10-30				
A19A2	002-364038-1	PRINTED CIRCUIT BOARD ASSEMBLY-ELECTRICAL EQUIPMENT	231	1
A19A2CR1	1N4007	DIODE (TYPICAL CR2 THRU CR10) (SUPERSEDED BY 132408-22)	231	1
A19A2CR1	132408-22	DIODE (TYPICAL CR2 THRU CR10) (SUPERSEDES 1N4007)	231	1
A19A2R1	RC42GF470K	RESISTOR	231	1
A19A2R2	RCR42GF510J	RESISTOR (ALTN FOR RC42GF510K) (TYPICAL R3 AND R4)	231	1
A19A2R2	RCR42GF510K	RESISTOR (ALTN FOR RC42GF510J) (TYPICAL R3 AND R4)	231	1

CODES OF EFFECTIVITY

1. E-1111, E-1241 THRU E-1765; CE-748, CE-772 THRU CE-918, CE-920 THRU CE-922, CE-924, CE-926, CE-928;
CJ-149 THRU CJ-155; D-10097, D-10120 THRU D-10353; EA-1 THRU EA-158

Raytheon Aircraft

BEECH BONANZA WIRING DIAGRAM MANUAL

39-10-40

**PRINTED CIRCUIT BOARD ASSEMBLY-FUEL QUANTITY INDICATOR (58-
364058-3)**

**E-1836 THRU E-1945, E-1947 THRU E-2103, E-2105 THRU E-2110; CE-947 THRU CE-1009; CJ-156 AND
AFTER; D-10370 AND AFTER; EA-213 THRU EA-319, EA-321 THRU EA-388**

Raytheon Aircraft

BEECH BONANZA WIRING DIAGRAM MANUAL

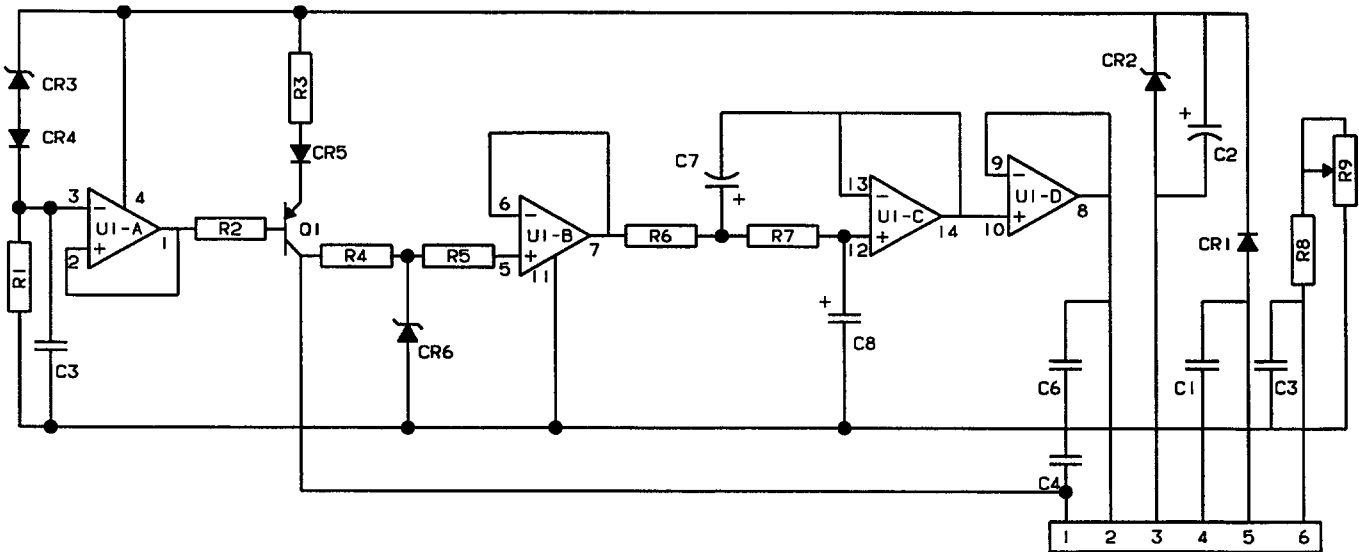
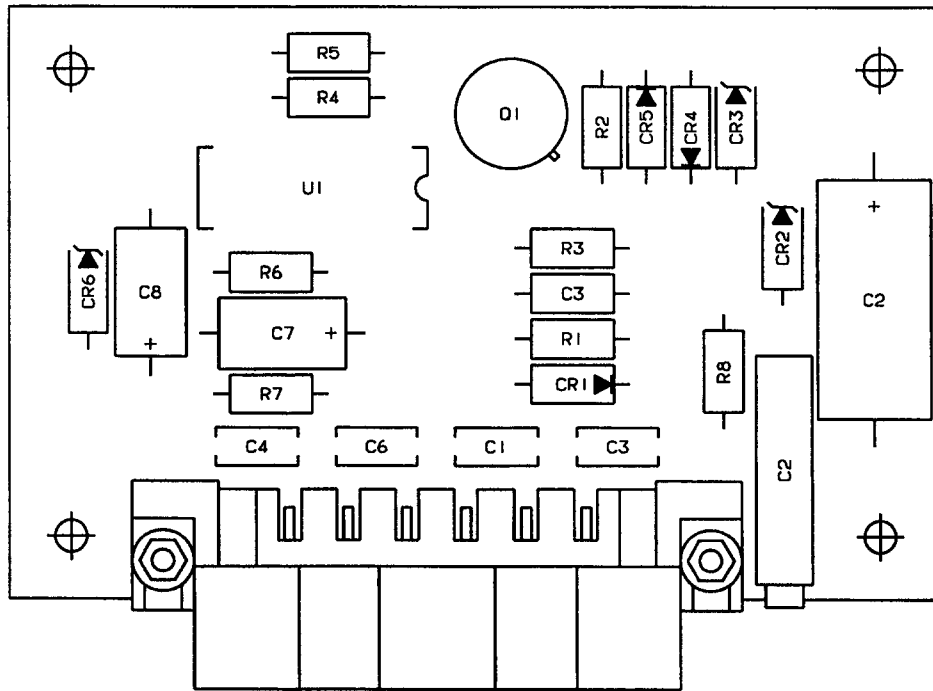

C95CE39F3290 C

**PRINTED CIRCUIT BOARD ASSEMBLY-FUEL QUANTITY INDICATOR (58-364058-3)
 E-1836 THRU E-1945, E-1947 THRU E-2103, E-2105 THRU E-2110; CE-947 THRU
 CE-1009; CJ-156 AND AFTER; D-10370 AND AFTER; EA-213 THRU EA-319, EA-321
 THRU EA-388**

Raytheon Aircraft

BEECH BONANZA WIRING DIAGRAM MANUAL

REFERENCE DESIGNATOR	PART NUMBER	DESCRIPTION	INSTL ZONE	USABLE ON CODE
39-10-40				
A27/A28	58-364058-3	PRINTED CIRCUIT BOARD ASSEMBLY-LEFT FUEL QUANTITY INDICATOR (TYPICAL BREAKDOWN FOR A28 RIGHT FUEL QUANTITY INDICATOR PCB)	240	1
CR1	1N4007	DIODE (SUPERSEDED BY 132408-22)	240	1
CR1	132408-22	DIODE (SUPERSEDES 1N4007)	240	1
CR2	1N4753	DIODE (SUPERSEDED BY 132409-47)	240	1
CR2	132409-47	DIODE (SUPERSEDES 1N4753)	240	1
CR3	1N4734A	DIODE (SUPERSEDED BY 132409-31)	240	1
CR3	132409-31	DIODE (SUPERSEDES 1N4734A)	240	1
CR4	1N3611	DIODE (SUPERSEDED BY 132408-18)	240	1
CR4	132408-18	DIODE (SUPERSEDES 1N3611)	240	1
CR5	1N3611	DIODE (SUPERSEDED BY 132408-18)	240	1
CR5	132408-18	DIODE (SUPERSEDES 1N3611)	240	1
CR6	1N4734A	DIODE (SUPERSEDED BY 132409-31)	240	1
CR6	132409-31	DIODE (SUPERSEDES 1N4734A)	240	1
C1	CKR06BX104KR	CAPACITOR (SUPERSEDED BY 132389D104EHM)	240	1
C1	132389D104EHM	CAPACITOR (SUPERSEDES CKR06BX104KR)	240	1
C2	150D476X9035S2	CAPACITOR (SUPERSEDED BY 132391D47R00FMU)	240	1
C2	132391D47R00FMU	CAPACITOR (SUPERSEDES 150D476X9035S2)	240	1
C3	CKR06BX104KR	CAPACITOR (SUPERSEDED BY 132389D104EHM)	240	1
C3	132389D104EHM	CAPACITOR (SUPERSEDES CKR06BX104KR)	240	1
C4	CKR06BX104KR	CAPACITOR (SUPERSEDED BY 132389D104EHM)	240	1
C4	132389D104EHM	CAPACITOR (SUPERSEDES CKR06BX104KR)	240	1
C5	CKR06BX104KR	CAPACITOR (SUPERSEDED BY 132389D104EHM)	240	1
C5	132389D104EHM	CAPACITOR (SUPERSEDES CKR06BX104KR)	240	1
C6	CK05BX471K	CAPACITOR (SUPERSEDED BY 132389C471EJM)	240	1
C7	162D476X9004DD2	CAPACITOR	240	1
C8	173D336X9006W	CAPACITOR	240	1
J1	207378-1	DIODE	240	1
Q1	2N4036	TRANSISTOR (SUPERSEDED BY 132404-15)	240	1
Q1	132404-15	TRANSISTOR (SUPERSEDES 2N4036)	240	1
R1	RCR07G302JS	RESISTOR (SUPERSEDED BY 132371B3001EBC)	240	1
R1	132371B3001EBC	RESISTOR (SUPERSEDES RCR07G302JS)	240	1
R2	RCR07G103JS	RESISTOR (SUPERSEDED BY 132371B1002EBC)	240	1
R2	132371B1002EBC	RESISTOR (SUPERSEDES RCR07G103JS)	240	1
R3	RCR07G471JS	RESISTOR (SUPERSEDED BY 132371B4700EBC)	240	1
R3	132371B4700EBC	RESISTOR (SUPERSEDES RLR07G471JS)	240	1
R4	RCR07G103JS	RESISTOR (SUPERSEDED BY 132371B1002EBC)	240	1
R4	132371B1002EBC	RESISTOR (SUPERSEDES RCR07G103JS)	240	1
R5	RCR07G103JS	RESISTOR (SUPERSEDED BY 132371B1002EBC)	240	1
R5	132371B1002EBC	RESISTOR (SUPERSEDES RCR07G103JS)	240	1
R6	RNC55H4992FS	RESISTOR (SUPERSEDED BY 132373D4992DBD)	240	1
R6	132373D4992DBD	RESISTOR (SUPERSEDES RNC55H4992FS)	240	1
R7	RNC55H5622FS	RESISTOR (SUPERSEDED BY 132373D5622DBD)	240	1
R7	132373D5622DBD	RESISTOR (SUPERSEDES RNC55H5622FS)	240	1
R8	RNR55C2321FM	RESISTOR	240	1
R9	3006P-1-501	POTENTIOMETER	240	1
U1	CA124G	AMPLIFIER	240	1

Raytheon Aircraft

BEECH BONANZA WIRING DIAGRAM MANUAL

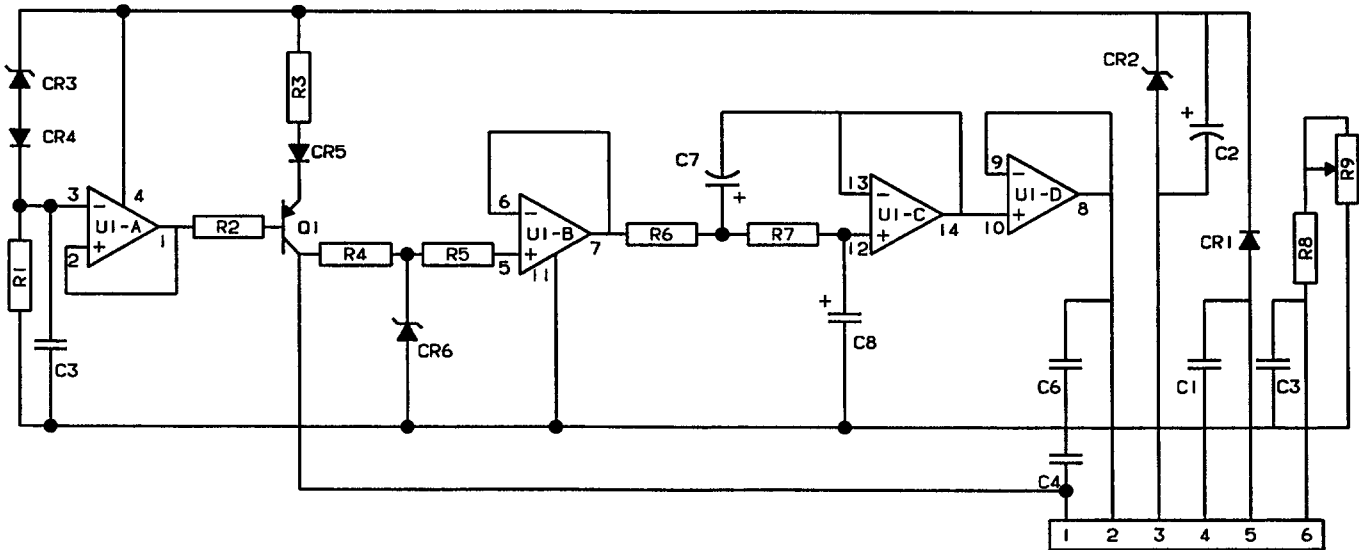
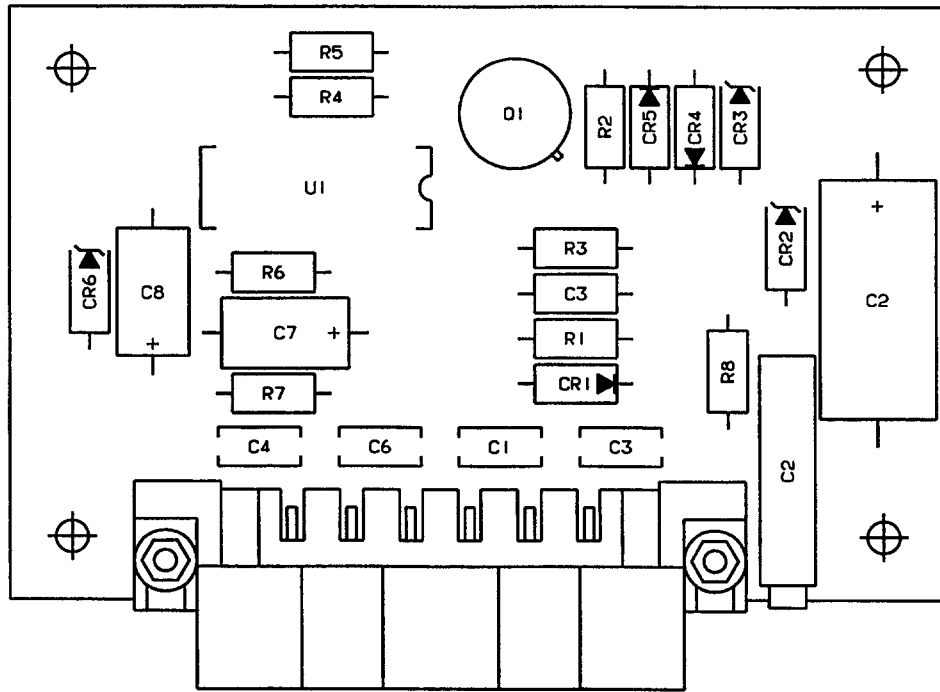

C95CE39F3290 C

PRINTED CIRCUIT BOARD ASSEMBLY-FUEL QUANTITY INDICATOR (58-364058-3)
 E-1836 THRU E-1945, E-1947 THRU E-2103, E-2105 THRU E-2110; CE-947 THRU
 CE-1009; CJ-156 AND AFTER; D-10370 AND AFTER; EA-213 THRU EA-319, EA-321
 THRU EA-388

Raytheon Aircraft

BEECH BONANZA WIRING DIAGRAM MANUAL

REFERENCE DESIGNATOR	PART NUMBER	DESCRIPTION	INSTL ZONE	USABLE ON CODE
		39-10-40		
W1	58-364059-1	PRINTED CIRCUIT BOARD	240	1

CODES OF EFFECTIVITY

1. E-1836 THRU E-1945, E-1947 THRU E-2103, E-2105 THRU E-2110; CE-947 THRU CE-1009; CJ-156 AND AFTER;
D-10370 AND AFTER; EA-213 THRU EA-319, EA-321 THRU EA-388

Raytheon Aircraft

BEECH BONANZA WIRING DIAGRAM MANUAL

39-10-41

**PRINTED CIRCUIT BOARD ASSEMBLY-FUEL QUANTITY INDICATOR (58-
364058-13)**

CE-1010 AND AFTER

Raytheon Aircraft

BEECH BONANZA WIRING DIAGRAM MANUAL

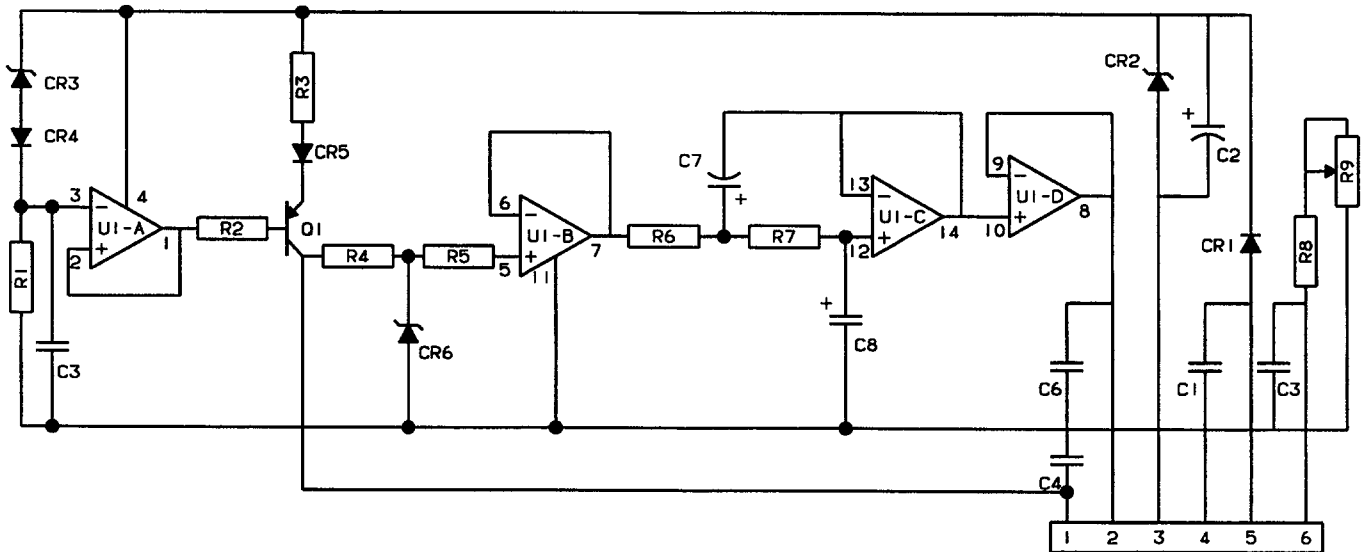
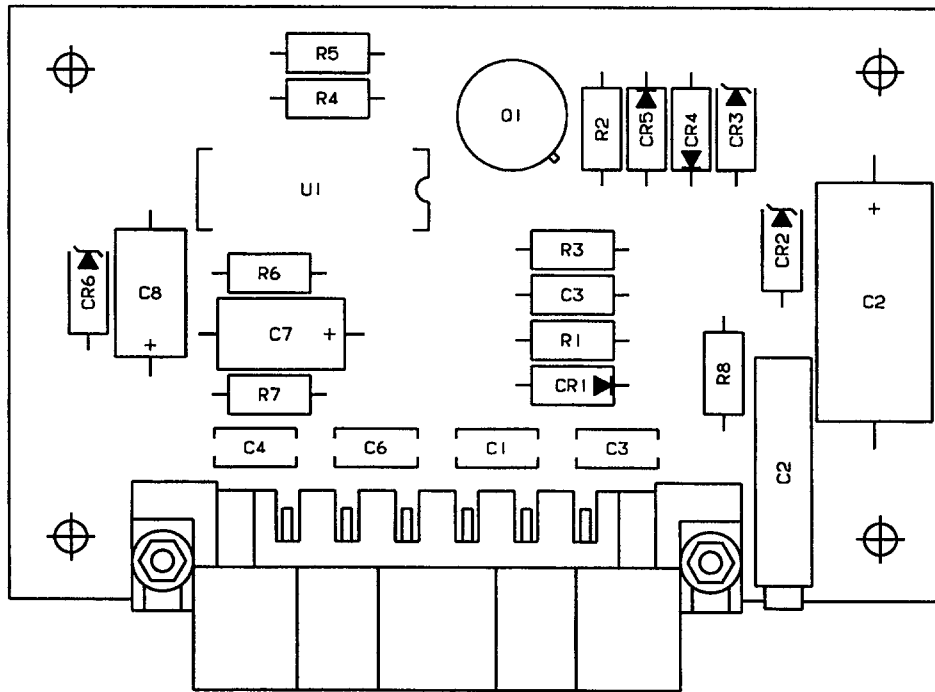

C95CE39F329 I C

PRINTED CIRCUIT BOARD ASSEMBLY-FUEL QUANTITY INDICATOR (58-364058-13) CE-1010 AND AFTER

Raytheon Aircraft

BEECH BONANZA WIRING DIAGRAM MANUAL

REFERENCE DESIGNATOR	PART NUMBER	DESCRIPTION	INSTL ZONE	USABLE ON CODE
39-10-41				
A27/A28	58-364058-13	PRINTED CIRCUIT BOARD ASSEMBLY-FUEL QUANTITY INDICATOR (TYPICAL A28 RH FUEL QTY INDICATOR)	240	1
CR1	1N4007	DIODE (SUPERSEDED BY 132408-22)	240	1
CR1	132408-22	DIODE (SUPERSEDES 1N4007)	240	1
CR2	1N4753	DIODE (SUPERSEDED BY 132409-47)	240	1
CR2	132409-47	DIODE (SUPERSEDES 1N4753)	240	1
CR3	1N4734A	DIODE (SUPERSEDED BY 132409-31)	240	1
CR3	132409-31	DIODE (SUPERSEDES 1N4734A)	240	1
CR4	1N3611	DIODE (SUPERSEDED BY 132408-18)	240	1
CR4	132408-18	DIODE (SUPERSEDES 1N3611)	240	1
CR5	1N3611	DIODE (SUPERSEDED BY 132408-18)	240	1
CR5	132408-18	DIODE (SUPERSEDES 1N3611)	240	1
CR6	1N4734A	SEMI-CONDUCTOR (SUPERSEDED BY 132409-31)	240	1
CR6	132409-31	SEMI-CONDUCTOR (SUPERSEDES 1N4734A)	240	1
C1	CKR06BX104KR	CAPACITOR (SUPERSEDED BY 132389D104EHM)	240	1
C1	132389D104EHM	CAPACITOR (SUPERSEDES CKR06BX104KR)	240	1
C2	150D476X9035S2	CAPACITOR (SUPERSEDED BY 132391D47R00FMU)	240	1
C2	132391D47R00FMU	CAPACITOR (SUPERSEDES 150D476X9035S2)	240	1
C3	CKR06BX104KR	CAPACITOR (SUPERSEDED BY 132389D104EHM)	240	1
C3	132389D104EHM	CAPACITOR (SUPERSEDES CKR06BX104KR)	240	1
C4	CKR06BX104KR	CAPACITOR (SUPERSEDED BY 132389D104EHM)	240	1
C4	132389D104EHM	CAPACITOR (SUPERSEDES CKR06BX104KR)	240	1
C5	CKR06BX104KR	CAPACITOR (SUPERSEDED BY 132389D104EHM)	240	1
C5	132389D104EHM	CAPACITOR (SUPERSEDES CKR06BX104KR)	240	1
C7	162D476X9004DD2	CAPACITOR	240	1
C8	173D336X9006W	CAPACITOR	240	1
J1	207378-1	HEADER-PIN	240	1
Q1	2N4036	TRANSISTOR (SUPERSEDED BY 132404-15)	240	1
Q1	132404-15	TRANSISTOR (SUPERSEDES 2N4036)	240	1
R1	RCR07G302JS	RESISTOR (SUPERSEDED BY 132371B3001EBC)	240	1
R1	132371B3001EBC	RESISTOR (SUPERSEDES RCR07G302JS)	240	1
R2	RCR07G102JS	RESISTOR (SUPERSEDED BY 132371B1001EBC)	240	1
R2	132371B1001EBC	RESISTOR (SUPERSEDES RCR07G102JS)	240	1
R3	RCR07G471JS	RESISTOR (SUPERSEDED BY 132371B4700EBC)	240	1
R3	132371B4700EBC	RESISTOR (SUPERSEDES RCR07G471JS)	240	1
R4	RCR07G103JS	RESISTOR (SUPERSEDED BY 132371B1002EBC)	240	1
R4	132371B1002EBC	RESISTOR (SUPERSEDES RCR07G103JS)	240	1
R5	RCR07G102JS	RESISTOR (SUPERSEDED BY 132371B1001EBC)	240	1
R6	RNC55H4992FS	RESISTOR (SUPERSEDED BY 132373D4992DBD)	240	1
R6	132373D4992DBD	RESISTOR (SUPERSEDES RNC55H4992FS)	240	1
R7	RNC55H5622FS	RESISTOR (SUPERSEDED BY 132373D5622DBD)	240	1
R7	132373D5622DBD	RESISTOR (SUPERSEDES RNC55H5622FS)	240	1
R8	RLR07C7500GR	RESISTOR (SUPERSEDED BY 132371B7500EBC)	240	1
R8	132371B7500EBC	RESISTOR (SUPERSEDES RLR07C7500GR)	240	1
R9	3006P-1-102	POTENTIOMETER	240	1
U1	CA124G	AMPLIFIER	240	1
W1	58-364059-1	PRINTED CIRCUIT BOARD	240	1

CODES OF EFFECTIVITY

1. CE-1010 AND AFTER

CHAPTER

73

**ENGINE FUEL
AND CONTROL**

Beechcraft
BONANZA
WIRING DIAGRAM MANUAL
LIST OF PAGES & TABLE OF CONTENTS
for
CHAPTER 73 - ENGINE FUEL SYSTEMS

SYS/SUB-SYS/ CHAP SECTION	PAGE NO.	EFFECTIVE DATE	TABLE OF CONTENTS
73-30-01	Page 1	OCT/95	INDICATING-FUEL FLOW SYSTEM
	Page 2	OCT/95	
	Page 3	OCT/95	

Beechcraft
BONANZA
WIRING DIAGRAM MANUAL

73-30-01

**E-1776 THRU E-1945, E-1947 THRU E-2103, E-2105 THRU E-2110;
CE-919, CE-929 AND AFTER; CJ-156 AND AFTER; D-10348, D-10354
AND AFTER; EA-159 THRU EA-319, EA-321 THRU EA-388**

Beechcraft BONANZA WIRING DIAGRAM MANUAL

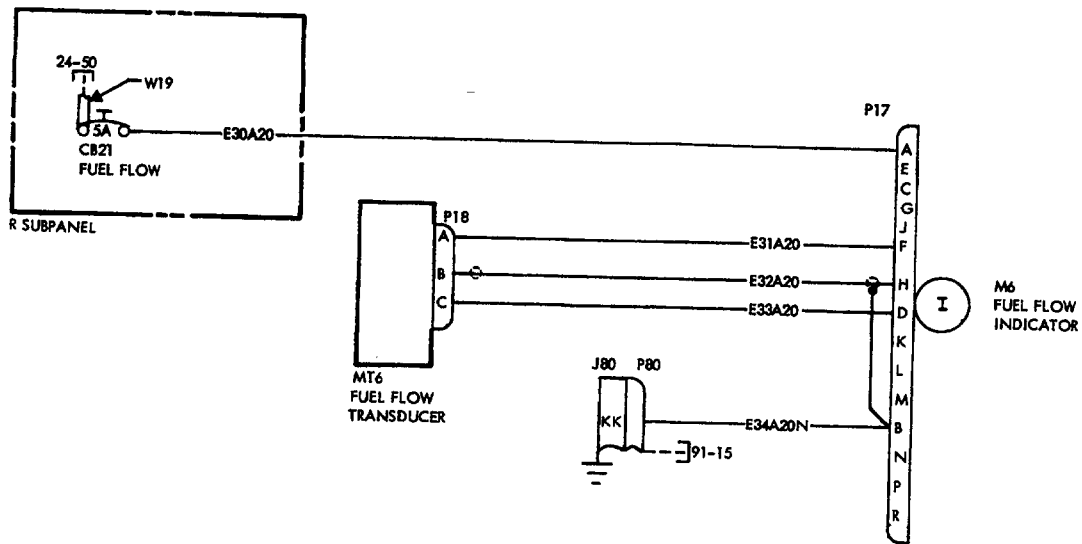

INDICATING-FUEL FLOW SYSTEM

Beechcraft
BONANZA
WIRING DIAGRAM MANUAL

REFERENCE DESIGNATOR	PART NUMBER	DESCRIPTION	USABLE	
			INSTL ZONE	ON CODE
73-30-01				
CB21	7277-2-5	CIRCUIT BREAKER-FUEL FLOW	240	1
J80	204814-1	RECEPTACLE-GROUNDING BLOCK	231	1
MT6	102-389012-5	TRANSDUCER-FUEL FLOW (ALTN FOR 102-389034-1)	410	1
MT6	102-389034-1	TRANSDUCER-FUEL FLOW (ALTN FOR 102-389012-5)	410	1
M6	36-380071-3	INDICATOR-FUEL FLOW MANIFOLD, PRESSURE (USED WITH POST LIGHTS)	240	1
M6	36-380073-3	INDICATOR-FUEL FLOW, MANIFOLD PRESSURE (USED WITH POST LIGHTS ONLY ON EA-1 THRU EA-319, EA-321 THRU EA-388)	240	1
M6	36-380070-3	INDICATOR-FUEL FLOW, MANIFOLD PRESSURE (USED WITH WEDGE LIGHTS)	240	1
M6	36-380072-3	INDICATOR-FUEL FLOW, MANIFOLD PRESSURE (USED WITH WEDGE LIGHTS ONLY ON EA-1 THRU EA-319, EA-321 THRU EA-388)	240	1
P17	PT06E14-15S/SR	PLUG-FUEL FLOW INDICATOR	240	1
P18	MS3108E10SL-3S	PLUG-FUEL FLOW TRANSDUCER (ALTN MS3108F10SL3S)	410	1
P18	MS3108F10SL-3S	PLUG-FUEL FLOW TRANSDUCER (ALTN MS3108E10SL3S)	410	1
P80A	200838-3	PLUG-GROUNDING BLOCK	231	1
P80B	201224-1	STRAIN RELIEF	231	1
P80C	201328-1	SOCKET CONTACT	231	1
P80D	200333-1	SOCKET CONTACT	231	1
P80E	203618-1	JACKSCREW	231	1
W19	114931-1-10	BUS BAR (OPTL)	240	1

EFFECTIVITY CODE

1. E-1766 THRU E-1945, E-1947 THRU E-2103, E-2105 THRU E-2110; CE-919, CE-929 AND AFTER;
CJ-156 AND AFTER; D-10348, D-10354 AND AFTER; EA-159 THRU EA-319, EA-321 THRU EA-388

CHAPTER

74

IGNITION

Beechcraft
BONANZA
WIRING DIAGRAM MANUAL
LIST OF PAGES & TABLE OF CONTENTS
for
CHAPTER 74 - IGNITION

SYS/SUB-SYS/ CHAP SECTION	PAGE NO.	EFFECTIVE DATE	TABLE OF CONTENTS
74-30-01	Page 1	OCT/95	IGNITION-SWITCHING
	Page 2	OCT/95	
	Page 3	OCT/95	
74-30-02	Page 1	OCT/95	IGNITION-SWITCHING
	Page 2	OCT/95	
	Page 3	OCT/95	

Beechcraft
BONANZA
WIRING DIAGRAM MANUAL

74-30-01

**E-1111, E-1241 THRU E-1945, E-1947 THRU E-2103, E-2105 THRU
E-2110; CE-748, CE-772 AND AFTER; CJ-149 AND AFTER; D-10097,
D-10120 AND AFTER**

Beechcraft BONANZA WIRING DIAGRAM MANUAL

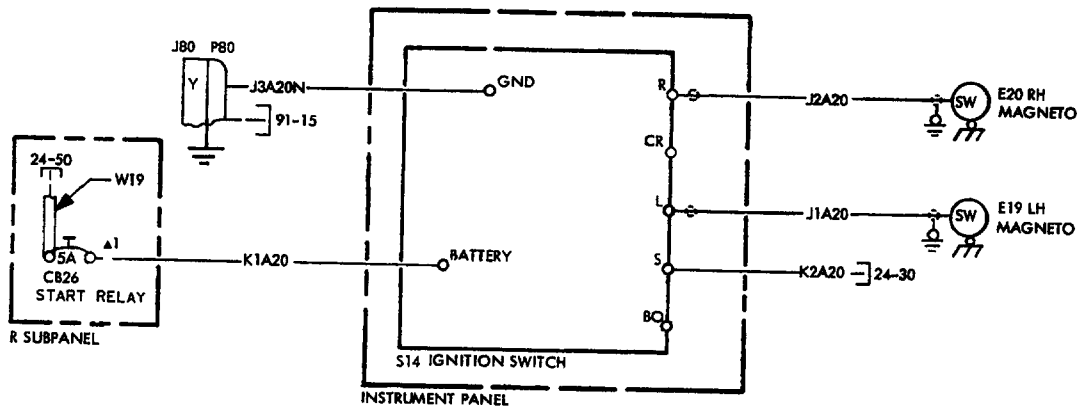

IGNITION-SWITCHING

Beechcraft
BONANZA
WIRING DIAGRAM MANUAL

REFERENCE DESIGNATOR	PART NUMBER	DESCRIPTION	USABLE	
			INSTL ZONE	ON CODE
74-30-01				
CB26	435-205-104	CIRCUIT BREAKER-START RELAY	240	4
CB26	7277-2-5	CIRCUIT BREAKER-START RELAY	240	5
E19	S6RN1225	MAGNETO-LEFT (ALTN FOR 640030)	410	2
E19	640030	MAGNETO-LEFT (ALTN FOR S6RN1225)	410	1
E19	6310	MAGNETO-RIGHT (SUPERSEDES S6RN1225)	410	3
E20	S6RN1225	MAGNETO-RIGHT (ALTN FOR 640030)	410	2
E20	640030	MAGNETO-RIGHT (ALTN FOR S6RN1225)	410	2
E20	6310	MAGNETO-RIGHT (SUPERSEDES S6RN1225)	410	3
J80	204814-1	RECEPTACLE-GROUNDING BLOCK	231	1
P80A	200838-3	PLUG-GROUNDING BLOCK	231	1
P80B	201224-1	STRAIN RELIEF	231	1
P80C	201328-1	SOCKET CONTACT	231	1
P80D	200333-1	SOCKET CONTACT	231	1
P80E	203618-1	JACKSCREW	231	1
S14	35-590099-33	SWITCH-IGNITION	240	1

EFFECTIVITY CODE

1. E-1111, E-1241 THRU E-1945, E-1947 THRU E-2103, E-2105 THRU E-2110; CE-748, CE-772 AND AFTER; CJ-149 AND AFTER; D-10097, D-10120 AND AFTER
2. E-1111, E-1241 THRU E-1945, E-1947 THRU E-2103, E-2105 THRU E-2110; CE-748, CE-772 THRU CE-1075; CJ-149 THRU CJ-155; D-10097, D-10120 AND AFTER
3. CE-1076 AND AFTER; CJ-156 AND AFTER
4. E-1111, E-1241 THRU E-1765; CE-748, CE-772 THRU CE-918, CE-920 THRU CE-928; CJ-149 THRU CJ-155; D-10097, D-10120 THRU D-10347, D-10349 THRU D-10353
5. E-1766 THRU E-1945, E-1947 THRU E-2103, E-2105 THRU E-2110; CE-919, CE-929 AND AFTER; CJ-156 AND AFTER; D-10348, D-10354 AND AFTER

Beechcraft
BONANZA
WIRING DIAGRAM MANUAL

74-30-02

EA-1 THRU EA-319, EA-321 THRU EA-388

Beechcraft BONANZA WIRING DIAGRAM MANUAL

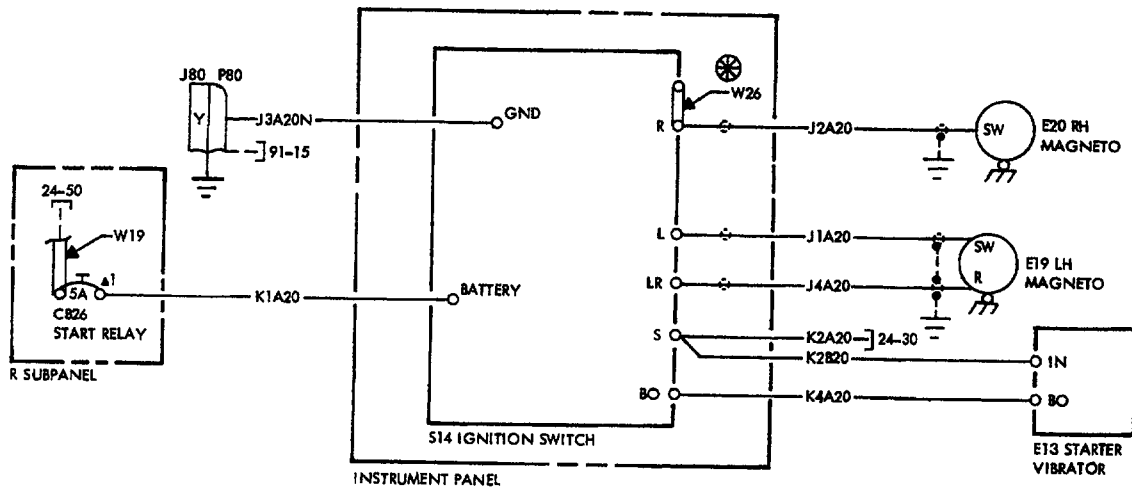

IGNITION-SWITCHING

Beechcraft
BONANZA
WIRING DIAGRAM MANUAL

REFERENCE DESIGNATOR	PART NUMBER	DESCRIPTION	USABLE	
			INSTL	ON ZONE CODE
74-30-02				
CB26	435-205-104	CIRCUIT BREAKER-START RELAY	240	2
CB26	7277-2-5	CIRCUIT BREAKER-START RELAY	240	3
E13	10-357487-242	STARTER VIBRATOR	240	1
E19	646981	MAGNETO-LEFT	410	1
E20	643808	MAGNETO-RIGHT	410	1
J80	204814-1	RECEPTACLE-GROUNDING BLOCK	231	1
P80A	200838-3	PLUG-GROUNDING BLOCK	231	1
P80B	201224-1	STRAIN RELIEF	231	1
P80C	201328-1	SOCKET CONTACT	231	1
P80D	200333-1	SOCKET CONTACT	231	1
P80E	203618-1	JACKSCREW	231	1
S14	35-590099-33	SWITCH-IGNITION	240	1
W19	114931-1-10	BUS BAR (OPTL)	240	1
W26	MCI-A106-7.5	LEADWIRE	240	1

EFFECTIVITY CODE

1. EA-1 THRU EA-319, EA-321 THRU EA-388
2. EA-1 THRU EA-158
3. EA-159 THRU EA-319, EA-321 THRU EA-388

CHAPTER

77

**ENGINE
INDICATING**

Beechcraft
BONANZA
WIRING DIAGRAM MANUAL
LIST OF PAGES & TABLE OF CONTENTS
for
CHAPTER 77 - ENGINE INDICATING

SYS/SUB-SYS/ CHAP SECTION	PAGE NO.	EFFECTIVE DATE	TABLE OF CONTENTS
77-20-01	Page 1	OCT/95	TEMPERATURE-ENGINE INSTRUMENT CLUSTER
	Page 2	OCT/95	
	Page 3	OCT/95	
77-30-01	Page 1	OCT/95	INDICATING SYSTEM-TURBINE INTAKE TEMPERATURE SYSTEM
	Page 2	OCT/95	
	Page 3	OCT/95	

Beechcraft
BONANZA
WIRING DIAGRAM MANUAL

77-20-01

**E-1111, E-1241 THRU E-1945, E-1947 THRU E-2103, E-2105 THRU
E-2110; CE-748, CE-772 AND AFTER; CJ-149 AND AFTER; D-10097,
D-10120 AND AFTER; EA-1 THRU EA-319, EA-321 THRU EA-388**

Beechcraft BONANZA WIRING DIAGRAM MANUAL

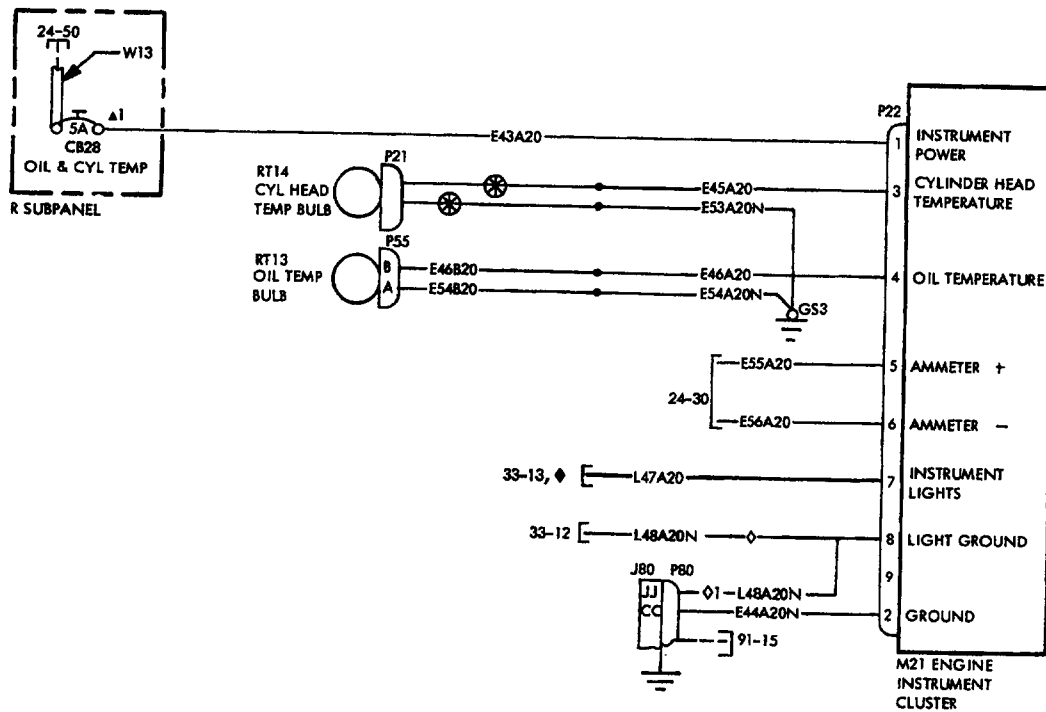

- ◇ ON ACFT E-1111, E-1241 THRU E-1666; EA-1 THRU EA-70; CE-748, CE-772 THRU CE-901; CJ-149 THRU CJ-155; D-10097, D-10120 THRU D-10342 WIRE REF TO 33-12.
- ◇ ON ACFT E-1667 & AFT; EA-71 & AFT; CE-902 & AFT; CJ-156 & AFT; D-10343 & AFT.
- ◆ ON AIRCRAFT HAVING OPTIONAL ENGINE INSTR WEDGE LIGHTS INSTALLED, REF DIAG 33-12.
- ◆ ON AIRCRAFT HAVING OPTIONAL INSTRUMENT POST LIGHTS INSTALLED, REF DIAG 33-17.

TEMPERATURE-ENGINE INSTRUMENT CLUSTER

Beechcraft
BONANZA
WIRING DIAGRAM MANUAL

REFERENCE DESIGNATOR	PART NUMBER	DESCRIPTION	USABLE INSTL ON ZONE CODE	
77-20-01				
CB28	435-205-104	CIRCUIT BREAKER-OIL AND CYLINDER HEAD TEMP	240	3
CB28	7277-2-5	CIRCUIT BREAKER-OIL AND CYLINDER HEAD TEMP	240	4
GS3	131270-3	GROUND STUD-FIREWALL	221	1
J80	204814-1	RECEPTACLE-GROUNDING BLOCK	231	1
M21	36-380044-1	ASSEMBLY-ENGINE INSTRUMENT CLUSTER	240	1
M21	36-380044-17	ASSEMBLY-ENGINE INSTRUMENT CLUSTER	240	2
M21	36-380044-3	GAGE-OIL TEMPERATURE	240	1
M21	36-380044-19	GAGE-OIL TEMPERATURE	240	2
M21	36-380044-5	GAGE-OIL PRESSURE	240	1
M21	36-380044-15	GAGE-OIL PRESSURE	240	2
M21	36-380044-7	GAGE-CYLINDER TEMPERATURE	240	1
M21	36-380044-9	GAGE-AMMETER	240	1
M21	36-380044-11	BOX	240	1
P21	CA3106E12S3S	PLUG-OIL TEMPERATURE	410	1
P22A	1-480277-0	PLUG-ENGINE INSTRUMENT CLUSTER	240	1
P22B	60618-1	SOCKET CONTACT	240	1
P55	AN4076-1	PLUG-CYLINDER HEAD TEMPERATURE	410	1
P80A	200838-3	PLUG-GROUNDING BLOCK	231	1
P80B	201224-1	STRAIN RELIEF	231	1
P80C	201328-1	SOCKET CONTACT	231	1
P80D	200333-1	SOCKET CONTACT	231	1
P80E	203618-1	JACKSCREW	231	1
RT13	MS24482-1	BULB-CYLINDER HEAD TEMPERATURE (USED ON LATER AIRPLANES) (USE AS SPARES REPLACEMENT FOR AN5546-1)	410	1
RT13	AN5546-1	BULB-CYLINDER HEAD TEMPERATURE (USED ON EARLIER AIRPLANES) (USE 102-000007 OR MS24482-1 FOR SPARES REPLACEMENT)	410	1
RT13	102-000007	BULB-CYLINDER HEAD TEMPERATURE (USE ON LATER AIRPLANES) (USE AS SPARES REPLACEMENT FOR AN5546-1)	410	1
RT14	MS28034-1	BULB-OIL TEMPERATURE	410	1

EFFECTIVITY CODE

1. E-1111, E-1241 THRU E-1945, E-1947 THRU E-2103, E-2105 THRU E-2110; CE-748, CE-772 AND AFTER; CJ-149 AND AFTER; D-10097, D-10120 AND AFTER; EA-1 THRU EA-319, EA-321 THRU EA-388
2. EA-1 THRU EA-319, EA-321 THRU EA-388
3. E-1111, E-1241 THRU E-1765; CE-748, CE-772 THRU CE-918, CE-920 THRU CE-928; CJ-149 THRU CJ-155; D-10097, D-10120 THRU D-10347, D-10349 THRU D-10353; EA-1 THRU EA-158
4. E-1766 THRU E-1945, E-1947 THRU E-2103, E-2105 THRU E-2110; CE-919, CE-929 AND AFTER; CJ-156 AND AFTER; D-10348, D-10354 AND AFTER; EA-159 THRU EA-319, EA-321 THRU EA-388

Beechcraft
BONANZA
WIRING DIAGRAM MANUAL

77-30-01

EA-1 THRU EA-319, EA-321 THRU EA-388

Beechcraft BONANZA WIRING DIAGRAM MANUAL

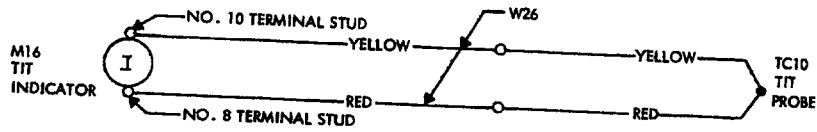

INDICATING SYSTEM-TURBINE INTAKE TEMPERATURE SYSTEM

Beechcraft
BONANZA
WIRING DIAGRAM MANUAL

REFERENCE DESIGNATOR	PART NUMBER	DESCRIPTION	USABLE	
			INSTL ZONE	ON CODE
77-30-01				
M16A	210-16BL/24	INDICATOR-TURBINE INTAKE TEMPERATURE	240	1
M16B	MCI-A106J1	PROBE	410	1
TC10	MC1-A106B	PROBE-TURBINE INTAKE TEPMERATURE	410	1
W26	MCI-A106-7.5	LEADWIRE	231	1

EFFECTIVITY CODE

1. EA-1 THRU EA-319, EA-321 THRU EA-388

CHAPTER

91

CHARTS

Raytheon Aircraft

BEECH BONANZA WIRING DIAGRAM MANUAL

LIST OF PAGES & TABLE OF CONTENTS for CHAPTER 91 - CHARTS

SYS/SUB-SYS/ CHAP SECTION	PAGE NO.	EFFECTIVE DATE	TABLE OF CONTENTS
91-01-01	Page 1 Page 2 Page 3	Oct/95 Oct/95 01/29/99	ELECTRICAL EQUIPMENT JUNCTION BOX E-1111, E-1241 THRU E-1370; CE-748, CE-772 THRU CE-815; D-10097, D-10120 THRU D-10178; EA-1 ONLY
91-01-02	Page 1 Page 2 Page 3	Oct/95 Oct/95 01/29/99	ELECTRICAL EQUIPMENT JUNCTION BOX E-1371 THRU E-1765; CE-816 THRU CE-918, CE-920 THRU CE-922, CE-924, CE-926, CE-928; CJ-149 THRU CJ-155; D-10179 THRU D-10353; EA-2 THRU EA-158
91-02-01	Page 1 Page 2 Page 3	Oct/95 Oct/95 Oct/95	ANNUNCIATOR LIGHT JUNCTION BOX ASSEMBLY E-1766 THRU E-1945, E-1947 THRU E-2103, E-2105 THRU E-2110; CE-919, CE-923, CE-925, CE-927, CE-929 THRU CE-1055; D-10354 THRU D-10403; EA-159 THRU EA-319, EA-321 THRU EA-388
91-02-02	Page 1 Page 2 Page 3	Oct/95 Oct/95 Oct/95	ANNUNCIATOR LIGHT JUNCTION BOX ASSEMBLY CE-1056 THRU CE-1300, CE-1302 THRU CE-1306; CJ-156 THRU CJ-179
91-02-03	Page 1 Page 2 Page 3	Oct/95 Oct/95 Oct/95	ANNUNCIATOR LIGHT JUNCTION BOX ASSEMBLY CE-1301, CE-1307 AND AFTER; CJ-180 AND AFTER
91-03-01	Page 1 Page 2 Page 3	Oct/95 Oct/95 01/29/99	LANDING GEAR SAFETY SYSTEM RELAY ASSEMBLY (OPTIONAL) (E-1911 THRU E-1945, E-1947 THRU E-2103, E-2105 THRU E-2110; CE-969 AND AFTER; D-10380 AND AFTER; EA-256 THRU EA-319, EA-321 THRU EA-388)
91-12-01	Page 1 Page 2 Page 3	Oct/95 Oct/95 Oct/95	CONNECTOR - WHEEL WELL ACCESS, LEFT WING (P/J10) E-1111, E-1241 THRU E-1370; CE-748, CE-772 THRU CE-815; CJ-149 ONLY; D-10097, D-10120 THRU D-10178
91-12-02 (Config 1)	Page 1 Page 2 Page 3	Oct/95 Oct/95 Oct/95	CONNECTOR - WHEEL WELL ACCESS, LEFT WING (P/J10) E-1371 THRU E-1945, E-1947 THRU E-2103, E-2105 THRU E-2110; CE-816 THRU CE-1300, CE-1302 THRU CE-1306; CJ-150 THRU CJ-179; D-10179 AND AFTER; EA-1 THRU EA-319, EA-321 THRU EA-388
91-12-02 (Config 2)	Page 1 Page 2 Page 3	Oct/95 Oct/95 Oct/95	CONNECTOR - WHEEL WELL ACCESS, LEFT WING (P/J10) CE-1301, CE-1307 AND AFTER; CJ-180 AND AFTER
91-13-01	Page 1 Page 2 Page 3	Oct/95 Oct/95 Oct/95	CONNECTOR - WHEEL WELL ACCESS, RIGHT WING (P/J11) (E-1111, E-1241 THRU E-1945, E-1947 THRU E-2103, E-2105 THRU E-2110; CE-748, CE-772 AND AFTER; CJ-149 AND AFTER; D-10097, D-10120 AND AFTER; EA-1 THRU EA-319, EA-321 THRU EA-388)

Raytheon Aircraft

BEECH BONANZA WIRING DIAGRAM MANUAL

LIST OF PAGES & TABLE OF CONTENTS (Continued)
for
CHAPTER 91 - CHARTS

SYS/SUB-SYS/ CHAP SECTION	PAGE NO.	EFFECTIVE DATE	TABLE OF CONTENTS
91-15-01	Page 1 Page 2 Page 3	Oct/95 Oct/95 Oct/95	CONNECTOR - INSTRUMENT PANEL GROUNDING (P/J80) E-1111, E-1241 THRU E-1786; CE-748, CE-772 THRU CE-933; CJ-149 THRU CJ-155; D-10097, D-10120 THRU D-10357; EA-1 THRU EA-173
91-15-02	Page 1 Page 2 Page 3	Oct/95 Oct/95 Oct/95	CONNECTOR - INSTRUMENT PANEL GROUNDING (P/J80) E-1787 THRU E-1945, E-1947 THRU E-2103, E-2105 THRU E-2110; CE-934 AND AFTER; CJ-156 AND AFTER; D-10358 AND AFTER; EA-174 THRU EA-319, EA-321 THRU EA-388
91-19-01	Page 1 Page 2 Page 3	Oct/95 Oct/95 Oct/95	JUNCTION BOX DISCONNECT (P/J54) E-1111, E-1241 THRU E-1370; CE-748, CE-772 THRU CE-815; D-10097, D-10120 THRU D-10178; EA-1 ONLY
91-19-02	Page 1 Page 2 Page 3	Oct/95 Oct/95 Oct/95	JUNCTION BOX DISCONNECT (P/J54) E-1371 THRU E-1765; CE-816 THRU CE-918, CE-920 THRU CE-922, CE-924, CE-926, CE-928; CJ-149 THRU CJ-155; D-10179 THRU D-10353; EA-2 THRU EA-158
91-19-03 (Config 1)	Page 1 Page 2 Page 3	Oct/95 Oct/95 Oct/95	JUNCTION BOX DISCONNECT (P/J54) E-1766 THRU E-1945, E-1947 THRU E-2103, E-2105 THRU E-2110; CE-919, CE-923, CE-925, CE-927, CE-929 THRU CE-1300, CE-1302 THRU CE-1306; CJ-156 THRU CJ-179; D-10354 AND AFTER; EA-159 THRU EA-319, EA-321 THRU EA-388
91-19-03 (Config 2)	Page 1 Page 2 Page 3	Oct/95 Oct/95 Oct/95	JUNCTION BOX DISCONNECT (P/J54) CE-1301, CE-1307 AND AFTER; CJ-180 AND AFTER
91-21-01 (Config 1)	Page 1 Page 2 Page 3	Oct/95 Oct/95 Oct/95	CROSSOVER DISCONNECT (P/J85) E-1111, E-1241 THRU E-1945, E-1947 THRU E-2103, E-2105 THRU E-2110; CE-748, CE-772 THRU CE-1300, CE-1302 THRU CE-1306; CJ-149 THRU CJ-179; D-10097, D-10120 AND AFTER; EA-1 THRU EA-319, EA-321 THRU EA-388
91-21-01 (Config 2)	Page 1 Page 2 Page 3	Oct/95 Oct/95 Oct/95	CROSSOVER DISCONNECT (P/J85) CE-1301, CE-1307 AND AFTER; CJ-180 AND AFTER
91-22-01	Page 1 Page 2 Page 3	Oct/95 Oct/95 Oct/95	CONNECTOR - GLARESHIELD (P/J31) CE-1301, CE-1307 AND AFTER; CJ-180 AND AFTER

Beechcraft
BONANZA
WIRING DIAGRAM MANUAL

91-01-01

**E-1111, E-1241 THRU E-1370; CE-748, CE-772 THRU CE-815; D-10097,
D-10120 THRU D-10178; EA-1 ONLY**

Beechcraft BONANZA WIRING DIAGRAM MANUAL

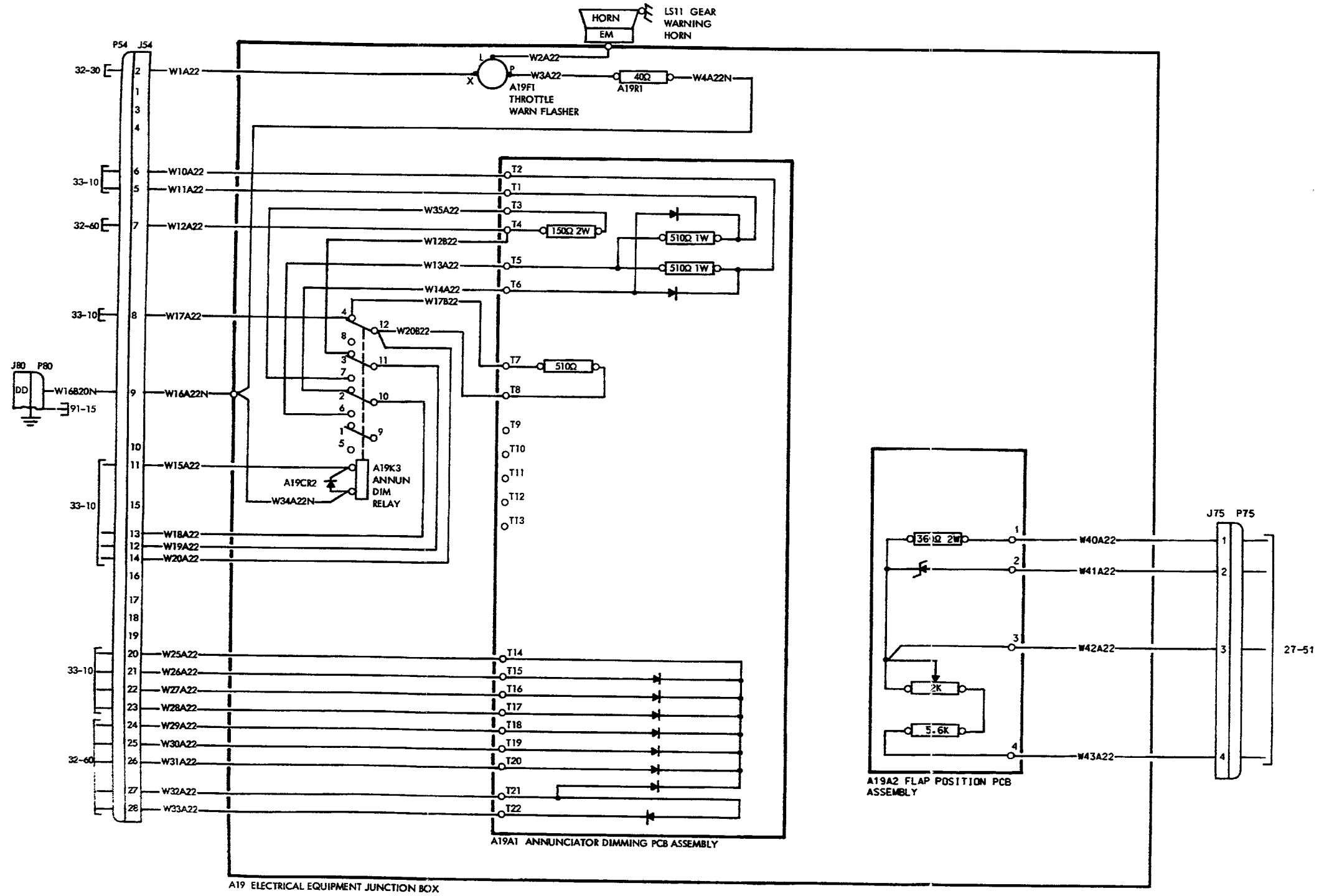

NOTE: ALL WIRES SHOWN, EXCEPT W16B, ARE NUMBERS OF THE A19 ASSY AND SHOULD BE SO PREFACED TO BE COMPLETE.

ELECTRICAL EQUIPMENT JUNCTION BOX

Raytheon Aircraft

BEECH BONANZA WIRING DIAGRAM MANUAL

REFERENCE DESIGNATOR	PART NUMBER	DESCRIPTION	INSTL ZONE	USABLE ON CODE
91-01-01				
A19	002-364037-3	JUNCTION BOX-ELECTRICAL EQUIPMENT	231	1
A19A1A	002-364038-3	PRINTED CIRCUIT BOARD ASSEMBLY-ANNUNCIATOR DIMMING	231	1
A19A1B	002-364039-1	PRINTED CIRCUIT BOARD	231	1
A19A1C	1N4007	DIODE (SUPERSEDED BY 132408-22)	231	1
A19A1C	132408-22	DIODE (SUPERSEDES 1N4007)	231	1
A19A1D	RC42GF470K	RESISTOR	231	1
A19A1E	RC32GF511J	RESISTOR	231	1
A19A1F	RC20GF511J	RESISTOR (SUPERSEDED BY 132371C5100EBC)	231	1
A19A1F	132371C5100EBC	RESISTOR (SUPERSEDES RC20GF511J)	231	1
A19A1G	2010B	TERMINAL	231	1
A19A2A	002-364040-3	PRINTED CIRCUIT BOARD ASSEMBLY-FLAP POSITION	231	1
A19A2B	002-364041	PRINTED CIRCUIT BOARD	231	1
A19A2C	1N4734	ZENER DIODE (SUPERSEDED BY 132409-31)	231	1
A19A2C	132409-31	ZENER DIODE (SUPERSEDES 1N4734)	231	1
A19A2D	RC42GF361J	RESISTOR	231	1
A19A2E	205-208	POTENTIOMETER	231	1
A19A2F	RCR20G562JS	RESISTOR (SUPERSEDED BY 132371C5601EBC)	231	1
A19A2F	132371C5601EBC	RESISTOR (SUPERSEDES RCR20G562JS)	231	1
A19A2G	2010B	TERMINAL	231	1
A19CR2	1N4007	RELAY-ANNUNCIATOR DIMMING (SUPERSEDED BY 132408-22)	231	1
A19CR2	132408-22	RELAY-ANNUNCIATOR DIMMING (SUPERSEDES 1N4007)	231	1
A19F1	R102	FLASHER-THROTTLE WARNING	231	1
A19K3	KHP17D11	RELAY-ANNUNCIATOR DIMMING (24 VDC) (ALTN FOR C281XDX1031)	231	1
A19K3	C281XDX1031	RELAY-ANNUNCIATOR DIMMING (24 VDC) (ALTN FOR KHP17D11)	231	1
A19LS11	169-380021-9	HORN-GEAR WARNING	231	1
A19R1	1 3/4D48F40	RESISTOR-THROTTLE FLASHING DROPPING	231	1
J54A	206152-1	RECEPTACLE-JUNCTION BOX ASSEMBLY	231	1
J54B	205089-1	PIN CONTACT	231	1
J54C	206138-1	CLAMP-STRAIN RELIEF	231	1
J75A	1-480426-0	RECEPTACLE-FLAP POSITION INDICATOR	231	1
J75B	60618-1	PIN CONTACT	231	1
J80	204814-1	RECEPTACLE-GROUNDING BLOCK	231	1
P54A	205839-3	PLUG-JUNCTION BOX ASSEMBLY	231	1
P54B	205090-1	SOCKET CONTACT	231	1
P54C	206138-1	CLAMP-STRAIN RELIEF	231	1
P75A	1-480424-0	PLUG-FLAP INDICATOR	231	1
P75B	60617-1	SOCKET CONTACT	231	1
P80A	200838-3	PLUG-GROUNDING BLOCK	231	1
P80B	201224-1	STRAIN RELIEF	231	1
P80C	201328-1	SOCKET CONTACT (20 GAGE)	231	1
P80D	200333-1	SOCKET CONTACT (16 OR 18 GAGE)	231	1
P80E	203618-1	JACKSCREW	231	1

CODES OF EFFECTIVITY

1. E-1111, E-1241 THRU E-1370; CE-748, CE-772 THRU CE-815; D-10097, D-10120 THRU D-10178; EA-1 ONLY

Beechcraft
BONANZA
WIRING DIAGRAM MANUAL

91-01-02

**E-1371 THRU E-1765; CE-816 THRU CE-918, CE-920 THRU CE-922,
CE-924, CE-926, CE-928; CJ-149 THRU CJ-155; D-10179 THRU
D-10353; EA-2 THRU EA-158**

Beechcraft BONANZA WIRING DIAGRAM MANUAL

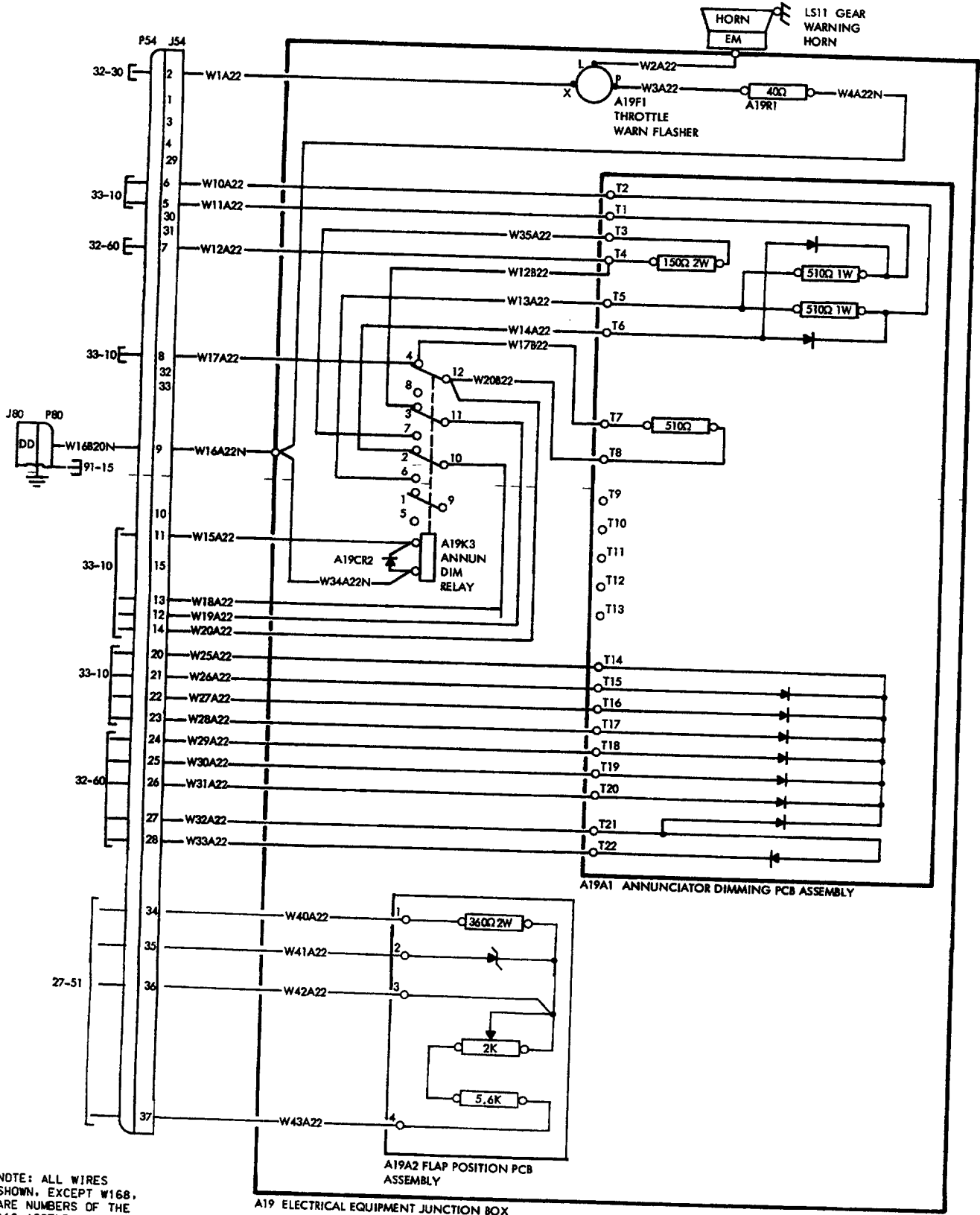

NOTE: ALL WIRES SHOWN, EXCEPT W168, ARE NUMBERS OF THE A19 ASSEMBLY AND SHOULD BE SO PREFACED TO BE COMPLETE.

ELECTRICAL EQUIPMENT JUNCTION BOX

Raytheon Aircraft

BEECH BONANZA WIRING DIAGRAM MANUAL

REFERENCE			INSTL	USABLE
DESIGNATOR	PART NUMBER	DESCRIPTION	ZONE	ON CODE
91-01-02				
A19	002-364037-15	JUNCTION BOX-ELECTRICAL EQUIPMENT	231	1
A19A1A	002-364038-3	PRINTED CIRCUIT BOARD ASSEMBLY-ANNUNCIATOR DIMMING	231	1
A19A1B	002-364039-1	PRINTED CIRCUIT BOARD	231	1
A19A1C	1N4007	DIODE (SUPERSEDED BY 132408-22)	231	1
A19A1C	132408-22	DIODE (SUPERSEDES 1N4007)	231	1
A19A1D	RC42G151KS	RESISTOR	231	1
A19A1E	RCR32G511JS	RESISTOR (SUPERSEDED BY 132371D5100EBC)	231	1
A19A1E	132371D5100EBC	RESISTOR (SUPERSEDES RCR32G511JS)	231	1
A19A1F	RCR20G511JS	RESISTOR (SUPERSEDED BY 132371C5100EBC)	231	1
A19A1F	132371C5100EBC	RESISTOR (SUPERSEDES RCR20G511JS)	231	1
A19A1G	2010B	TERMINAL	231	1
A19A2A	002-364040-3	PRINTED CIRCUIT BOARD ASSEMBLY-FLAP POSITION	231	1
A19A2B	002-364041	PRINTED CIRCUIT BOARD	231	1
A19A2C	1N4734	ZENER DIODE (SUPERSEDED BY 132409-31)	231	1
A19A2C	132409-31	ZENER DIODE (SUPERSEDES 1N4734)	231	1
A19A2D	RCR42G361JS	RESISTOR (SUPERSEDED BY 132371E3600EFA)	231	1
A19A2D	132371E3600EFA	RESISTOR (SUPERSEDES RCR42G361JS)	231	1
A19A2E	205-208	POTENTIOMETER	231	1
A19A2F	RCR20G562JS	RESISTOR (SUPERSEDED BY 132371C5601EBC)	231	1
A19A2F	132371C5601EBC	RESISTOR (SUPERSEDES RCR20G562JS)	231	1
A19A2G	2010B	TERMINAL	231	1
A19CR2	1N4007	DIODE (SUPERSEDED BY 132408-22)	231	1
A19CR2	132408-22	DIODE (SUPERSEDES 1N4007)	231	1
A19F1	R102	FLASHER-THROTTLE WARNING	231	1
A19K3	KHP17D11	RELAY-ANNUNCIATOR DIMMING (24 VDC) (ALTN FOR C281XDX1031)	231	1
A19K3	C281XDX1031	RELAY-ANNUNCIATOR DIMMING (24 VDC) (ALTN FOR KHP17D11)	231	1
A19LS11	169-380021-9	HORN-GEAR WARNING	231	1
A19R1	1 3/4D48F40	RESISTOR-THROTTLE FLASHING DROPPING	231	1
J54A	206151-2	RECEPTACLE-JUNCTION BOX ASSEMBLY	231	1
J54B	66103-2	PIN CONTACT	231	1
J54C	206138-1	CLAMP-STRAIN RELIEF	231	1
J80	204814-1	RECEPTACLE-GROUNDING BLOCK	231	1
P54A	206150-1	PLUG-JUNCTION BOX ASSEMBLY	231	1
P54B	66105-2	SOCKET CONTACT	231	1
P54C	206138-1	CLAMP-STRAIN RELIEF	231	1
P80A	200838-3	PLUG-GROUNDING BLOCK	231	1
P80B	201224-1	STRAIN RELIEF	231	1
P80C	201328-1	SOCKET CONTACT (20 GAGE)	231	1
P80D	200333-1	SOCKET CONTACT (16 OR 18 GAGE)	231	1
P80E	203618-1	JACKSCREW	231	1

CODES OF EFFECTIVITY

1. E-1371 THRU E-1765; CE-816 THRU CE-918, CE-920 THRU CE-922, CE-924, CE-926, CE-928; CJ-149 THRU CJ-155; D-10179 THRU D-10353; EA-2 THRU EA-158

Beechcraft
BONANZA
WIRING DIAGRAM MANUAL

91-02-01

**E-1766 THRU E-1945, E-1947 THRU E-2103, E-2105 THRU E-2110;
CE-919, CE-923, CE-925, CE-927, CE-929 THRU CE-1055; D-10354
THRU D-10403; EA-159 THRU EA-319, EA-321 THRU EA-388**

Beechcraft BONANZA WIRING DIAGRAM MANUAL

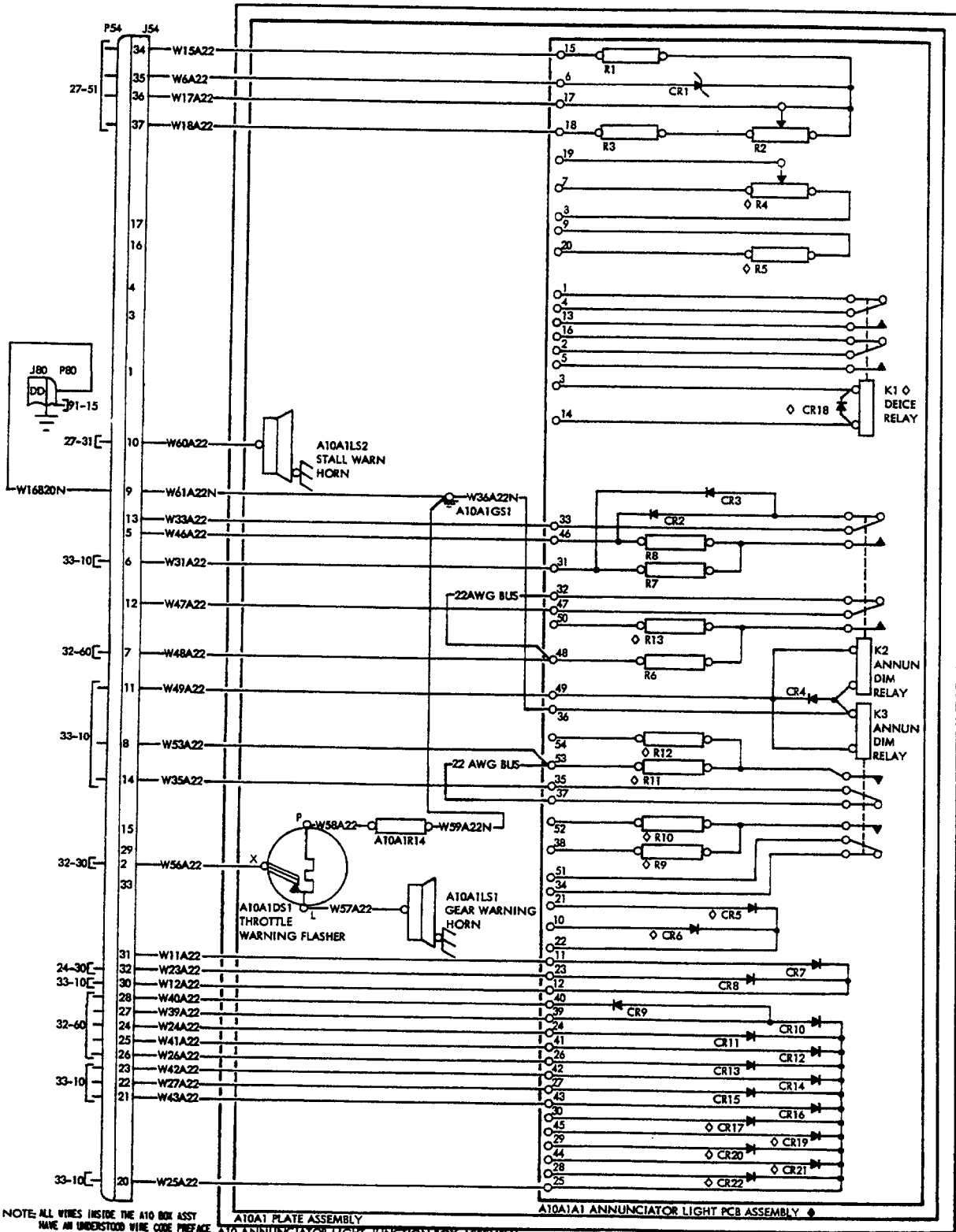

NOTE: ALL WIRES INSIDE THE A10 BOX ASSY HAVE AN UNDERSTOOD WIRE CODE PREFACE OF A10. PHYSICALLY ADDING THE A10 PREFACE TO THE WIRE CODES IS NOT REQUIRED.

- ◆ FOR COMPLETE REF DES PREFACE WITH A10A1A1.
- ◇ COMPONENT IS NOT INSTALLED; SPACE PROVIDED FOR FUTURE GROWTH.

ANNUNCIATOR LIGHT JUNCTION BOX ASSEMBLY

Beechcraft
BONANZA
WIRING DIAGRAM MANUAL

REFERENCE DESIGNATOR	PART NUMBER	DESCRIPTION	USABLE INSTL ON ZONE CODE
91-02-01			
A10	58-364056-1	BOX ASSEMBLY-JUNCTION, ANNUNCIATOR LIGHT	231 1
A10A1	58-364056	PLATE ASSEMBLY	231 1
A10A1A1	58-364055-1	PRINTED CIRCUIT BOARD ASSEMBLY-ANNUNCIATOR LIGHT	231 1
A10A1DS1	R102	FLASHER-THROTTLE WARNING	231 1
A10A1GS1	131270-3	GROUND STUD	231 1
A10A1LS1	169-380021-9	HORN-GEAR WARNING	231 1
A10A1LS2	169-380021-11	STALL WARNING HORN	231 1
A10A1R14	1717	RESISTOR-THROTTLE WARNING FLASHER	231 1
J54A	206151-2	RECEPTACLE-JUNCTION BOX ASSEMBLY	231 1
J54B	206138-1	STRAIN RELIEF	231 1
J54C	66103-2	PIN CONTACT	231 1
J80	204814-1	RECEPTACLE-GROUNDING BLOCK	231 1
P54A	206150-1	PLUG-JUNCTION BOX ASSEMBLY	231 1
P54B	206138-1	STRAIN RELIEF	231 1
P54C	66105-2	SOCKET CONTACT	231 1
P80A	200838-3	PLUG-GROUNDING BLOCK	231 1
P80B	201224-1	STRAIN RELIEF	231 1
P80C	201328-1	SOCKET CONTACT (20 GAGE)	231 1
P80D	200333-1	SOCKET CONTACT (16 OR 18 GAGE)	231 1
P80E	203618-1	JACKSCREW	231 1

NOTE

FOR INTERNAL COMPONENTS OF A10A1A1 ANNUNCIATOR
LIGHT PRINTED CIRCUIT BOARD REFERENCE CHAPTER 39.

EFFECTIVITY CODE

1. E-1766 THRU E-1945, E-1947 THRU E-2103, E-2105 THRU E-2110; CE-919, CE-923, CE-925,
CE-929 THRU CE-1055; D-10354 THRU D-10403; EA-159 THRU EA-319, EA-321 THRU EA-388

Beechcraft
BONANZA
WIRING DIAGRAM MANUAL

91-02-02

**CE-1056 THRU CE-1300, CE-1302 THRU CE-1306; CJ-156 THRU
CJ-179**

Beechcraft BONANZA WIRING DIAGRAM MANUAL

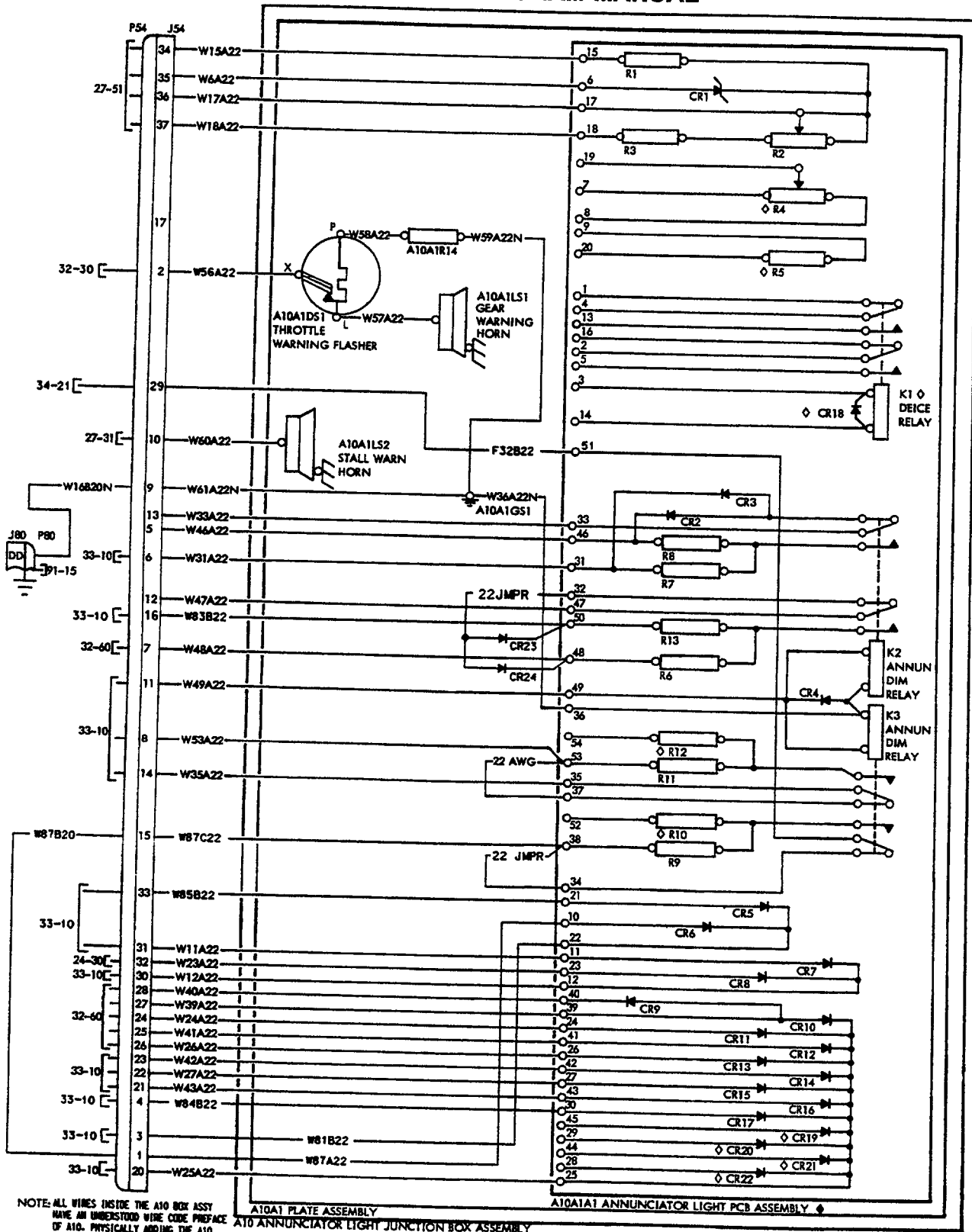

NOTE: ALL WIRES INSIDE THE A10 BOX ASSY HAVE AN UNDERSTOOD WIRE CODE PREFACE OF A10. PHYSICALLY ADDING THE A10 PREFACE TO THE WIRE CODES IS NOT REQUIRED.

- ◆ FOR COMPLETE REF DES PREFACE WITH A10A1A1.
- ◇ COMPONENT IS NOT INSTALLED; SPACE PROVIDED FOR FUTURE GROWTH.

ANNUNCIATOR LIGHT JUNCTION BOX ASSEMBLY

Beechcraft
BONANZA
WIRING DIAGRAM MANUAL

REFERENCE DESIGNATOR	PART NUMBER	DESCRIPTION	USABLE INSTL ON ZONE CODE
91-02-02			
A10	58-364056-13	BOX ASSEMBLY-JUNCTION, ANNUNCIATOR LIGHT	231 1
A10A1	58-364056-1	PLATE ASSEMBLY	231 1
A10A1A1	58-364055-1	PRINTED CIRCUIT BOARD ASSEMBLY-ANNUNCIATOR LIGHT	231 1
A10A1DS1	R102	FLASHER-THROTTLE WARNING	231 1
A10A1GS1	131270-3	GROUND STUD	231 1
A10A1LS1	169-380021-9	HORN-GEAR WARNING	231 1
A10A1LS2	169-380021-11	STALL WARNING HORN	231 1
A10A1R14	1717	RESISTOR-THROTTLE WARNING FLASHER	231 1
J54A	206151-2	RECEPTACLE-JUNCTION BOX ASSEMBLY	231 1
J54B	206138-1	STRAIN RELIEF	231 1
J54C	66103-2	PIN CONTACT	231 1
J80	204814-1	RECEPTACLE-GROUNDING BLOCK	231 1
P54A	206150-1	PLUG-JUNCTION BOX ASSEMBLY	231 1
P54B	206138-1	STRAIN RELIEF	231 1
P54C	66105-2	SOCKET CONTACT	231 1
P80A	200838-3	PLUG-GROUNDING BLOCK	231 1
P80B	201224-1	STRAIN RELIEF	231 1
P80C	201328-1	SOCKET CONTACT (20 GAGE)	231 1
P80D	200333-1	SOCKET CONTACT (16 OR 18 GAGE)	231 1
P80E	203618-1	JACKSCREW	231 1

NOTE

FOR INTERNAL COMPONENTS OF A10A1A1 ANNUNCIATOR
LIGHT PRINTED CIRCUIT BOARD REFERENCE CHAPTER 39.

EFFECTIVITY CODE

1. CE-1056 THRU CE-1300, CE-1302 THRU CE-1306; CJ-156 THRU CJ-179; D-10404 AND AFTER

Beechcraft
BONANZA
WIRING DIAGRAM MANUAL

91-02-03

CE-1301, CE-1307 AND AFTER; CJ-180 AND AFTER

Beechcraft BONANZA WIRING DIAGRAM MANUAL

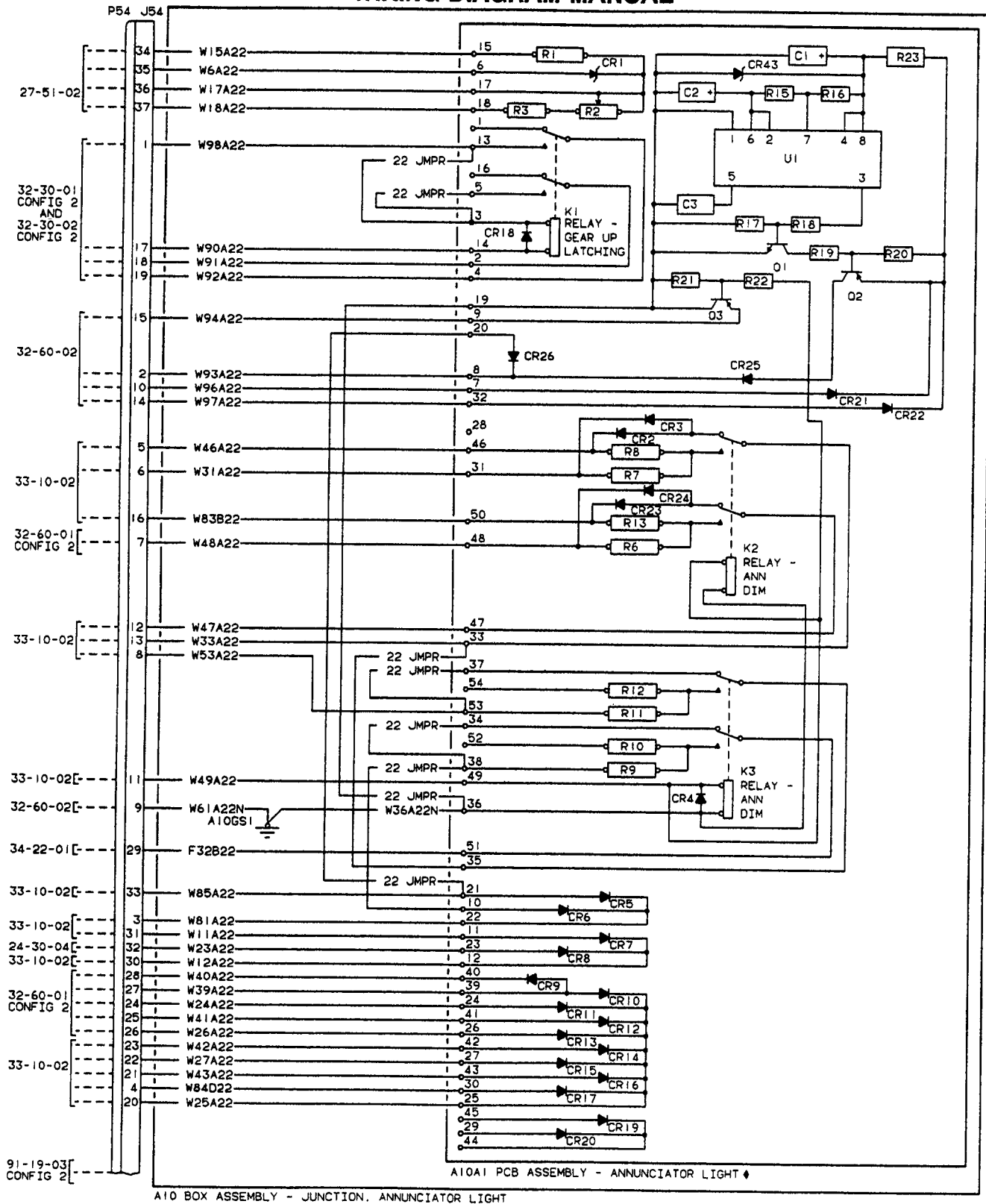

NOTE: ALL WIRES INSIDE THE A10 BOX ASSY HAVE AN UNDERSTOOD WIRE CODE PREFACE OF A10. PHYSICALLY ADDING THE A10 PREFACE TO THE WIRE CODES IS NOT REQUIRED. ♦ FOR COMPLETE REF DES PREFACE WITH A10A1A1.

ANNUNCIATOR LIGHT JUNCTION BOX ASSEMBLY

Beechcraft
BONANZA
WIRING DIAGRAM MANUAL

REFERENCE DESIGNATOR	PART NUMBER	DESCRIPTION	USABLE INSTL ON ZONE CODE	
		91-02-03		
A10	58-364056-15	BOX ASSEMBLY-JUNCTION, ANNUNCIATOR LIGHT	231	1
A10A1	58-364055-7	PRINTED CIRCUIT BOARD ASSEMBLY-ANNUNCIATOR LIGHT	231	1
A10GS1	131270-3S	GROUND STUD	231	1

NOTE

FOR INTERNAL COMPONENTS OF A10A1A1 ANNUNCIATOR
LIGHT PRINTED CIRCUIT BOARD REFERENCE CHAPTER 39.

EFFECTIVITY CODE

1. CE-1301, CE-1307 AND AFTER; CJ-180 AND AFTER

Beechcraft
BONANZA
WIRING DIAGRAM MANUAL

91-03-01

**E-1911 THRU E-1945, E-1947 THRU E-2103, E-2105 THRU E-2110;
CE-969 AND AFTER; D-10380 AND AFTER; EA-256 THRU EA-319,
EA-321 THRU EA-388**

Beechcraft BONANZA WIRING DIAGRAM MANUAL

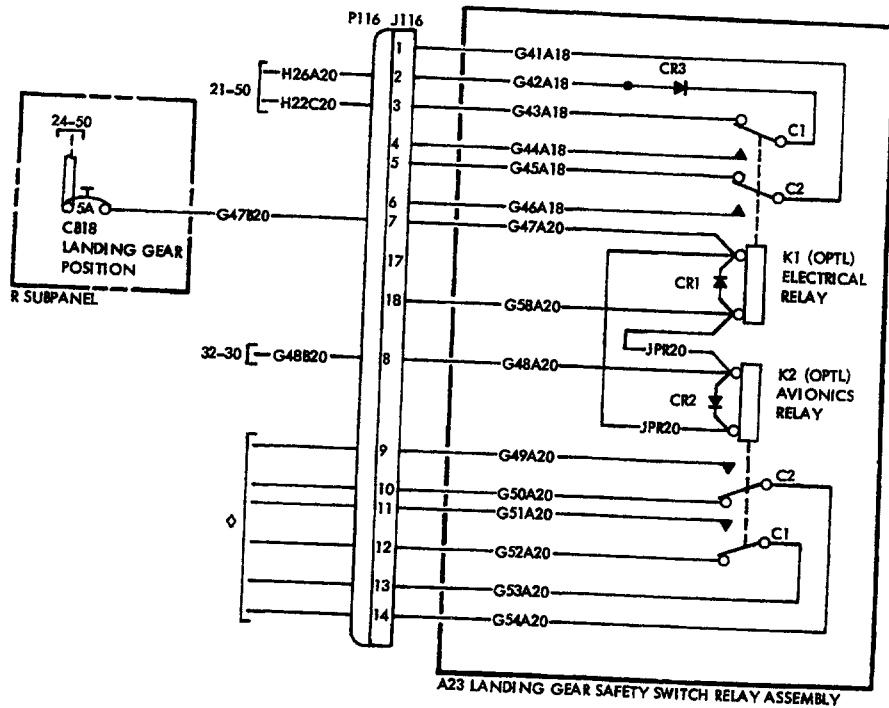

◇ REFER TO APPLICABLE AVIONICS DWG
FOR MODE OF CONNECTION.

LANDING GEAR SAFETY SYSTEM RELAY ASSEMBLY (OPTIONAL)

Raytheon Aircraft

BEECH BONANZA WIRING DIAGRAM MANUAL

REFERENCE DESIGNATOR	PART NUMBER	DESCRIPTION	INSTL ZONE	USABLE ON CODE
91-03-01				
A23	58-364061-1	LANDING GEAR SAFETY SWITCH RELAY ASSEMBLY	251	1
A23CR1	1N4007	DIODE-ELECTRICAL RELAY (SUPERSEDED BY 132408-22)	251	1
A23CR1	132408-22	DIODE-ELECTRICAL RELAY (SUPERSEDES 1N4007)	251	1
A23CR2	1N4007	DIODE-AVIONICS RELAY (SUPERSEDED BY 132408-22)	251	1
A23CR2	132408-22	DIODE-AVIONICS RELAY (SUPERSEDES 1N4007)	251	1
A23CR3	1N5404	DIODE-AIR CONDITIONING BLOCKING	251	1
A23K1	50-380048-11	ELECTRICAL RELAY (OPTL)	251	1
A23K2	50-384112-1	AVIONICS RELAY (OPTL)	251	1
CB18	7277-2-5	CIRCUIT BREAKER-LANDING GEAR POSITION	240	1
J116	207443-1	RECEPTACLE-LANDING GEAR SAFETY SWITCH RELAY ASSEMBLY	251	1
P116	207442-1	PLUG-LANDING GEAR SAFETY SWITCH RELAY ASSEMBLY	251	1

CODES OF EFFECTIVITY

1. E-1911 THRU E-1945, E-1947 THRU E-2103, E-2105 THRU E-2110; CE-969 AND AFTER; D-10380 AND AFTER; EA-256 THRU EA-319, EA-321 THRU EA-388

Beechcraft
BONANZA
WIRING DIAGRAM MANUAL

91-12-01

**E-1111, E-1241 THRU E-1370; CE-748, CE-772 THRU CE-815; CJ-149
ONLY; D-10097, D-10120 THRU D-10178**

Beechcraft BONANZA WIRING DIAGRAM MANUAL

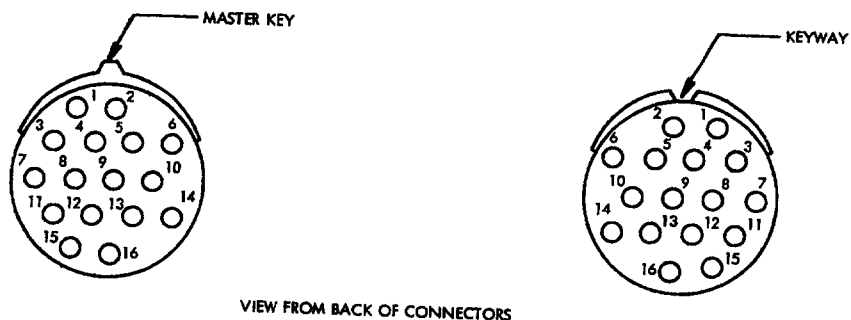

VIEW FROM BACK OF CONNECTORS

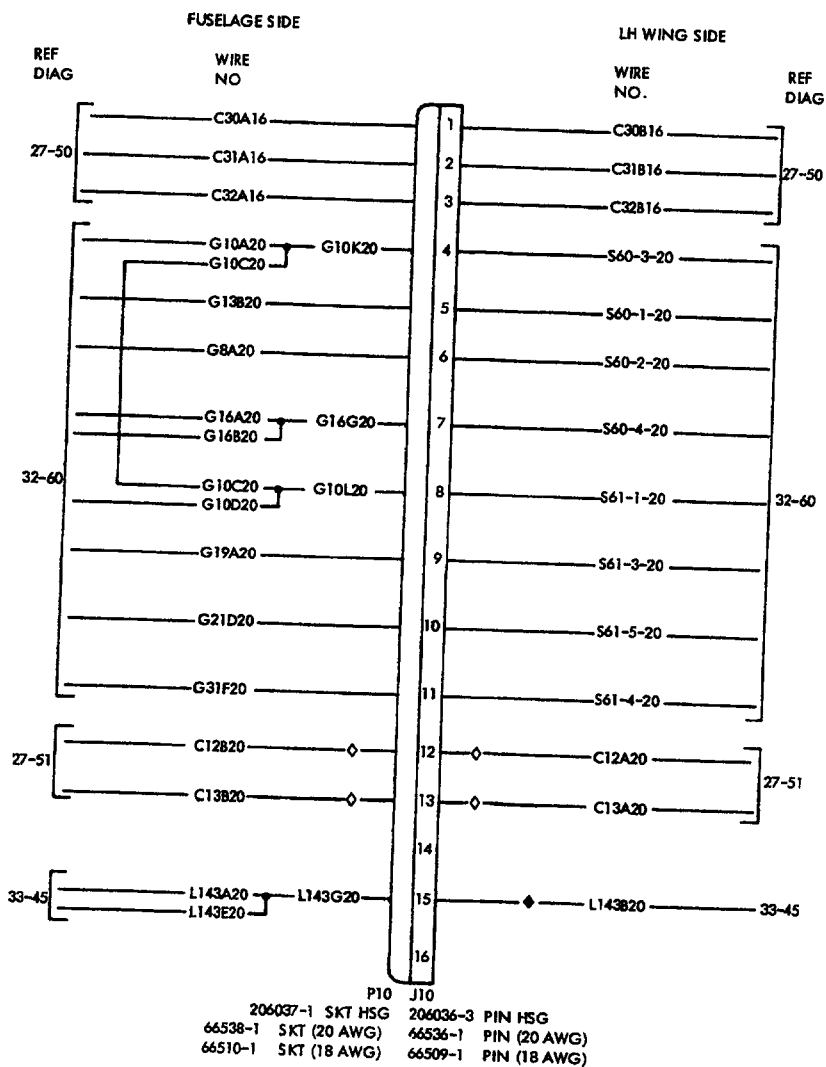

◆ WIRE NUMBERS DUPLICATED ON CHART 91-13 FOR LEFT AND RIGHT WIRE HARNESS INTERCHANGEABILITY.

◇ ON ACFT C.J-149 ONLY THESE WIRES TERMINATE IN CONN P/J44 (SEE DIAG 27-51-02)

USE OF FOLLOWING TOOLS REQUIRED:

INSERTION TOOL: 91002-1 (18 & 20 AWG)
 EXTRACTION TOOL: 305183 (18 & 20 AWG)
 CRIMPING TOOL: 90203-1 (18 & 20 AWG)
 STRAIN RELIEF: 206070-1 (AMP, INC)

CONNECTOR-WHEEL WELL ACCESS, LEFT WING (P/J10)

Beechcraft
BONANZA
WIRING DIAGRAM MANUAL

REFERENCE DESIGNATOR	PART NUMBER	DESCRIPTION	USABLE	
			INSTL ZONE	ON CODE
91-12-01				
J10A	206036-3	RECEPTACLE-LEFT WHEEL WELL ACCESS	532	1
J10B	206070-1	STRAIN RELIEF	532	1
J10C	66103-2	PIN CONTACT (20 GAGE)	532	1
J10D	66099-2	PIN CONTACT (18 GAGE)	532	1
P10A	206037-1	PLUG-LEFT WHEEL WELL ACCESS	532	1
P10B	206070-1	STRAIN RELIEF CLAMP	532	1
P10C	66105-2	SOCKET CONTACT (20 GAGE)	532	1
P10D	66101-2	SOCKET CONTACT (18 GAGE)	532	1

EFFECTIVITY CODE

1. E-1111, E-1241 THRU E-1370; CE-748, CE-772 THRU CE-815; CJ-149 ONLY; D-10097, D-10120
 THRU D-10178

Beechcraft
BONANZA
WIRING DIAGRAM MANUAL

91-12-02

Configuration 1

**E-1371 THRU E-1945, E-1947 THRU E-2103, E-2105 THRU E-2110;
CE-816 THRU CE-1300, CE-1302 THRU CE-1306; CJ-150 THRU CJ-179;
D-10179 AND AFTER; EA-1 THRU EA-319, EA-321 THRU EA-388**

Beechcraft BONANZA WIRING DIAGRAM MANUAL

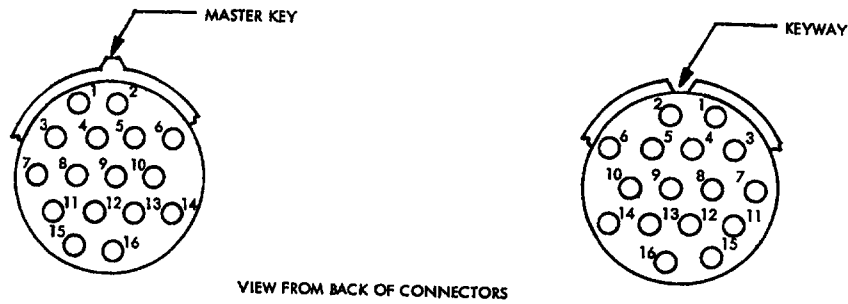

VIEW FROM BACK OF CONNECTORS

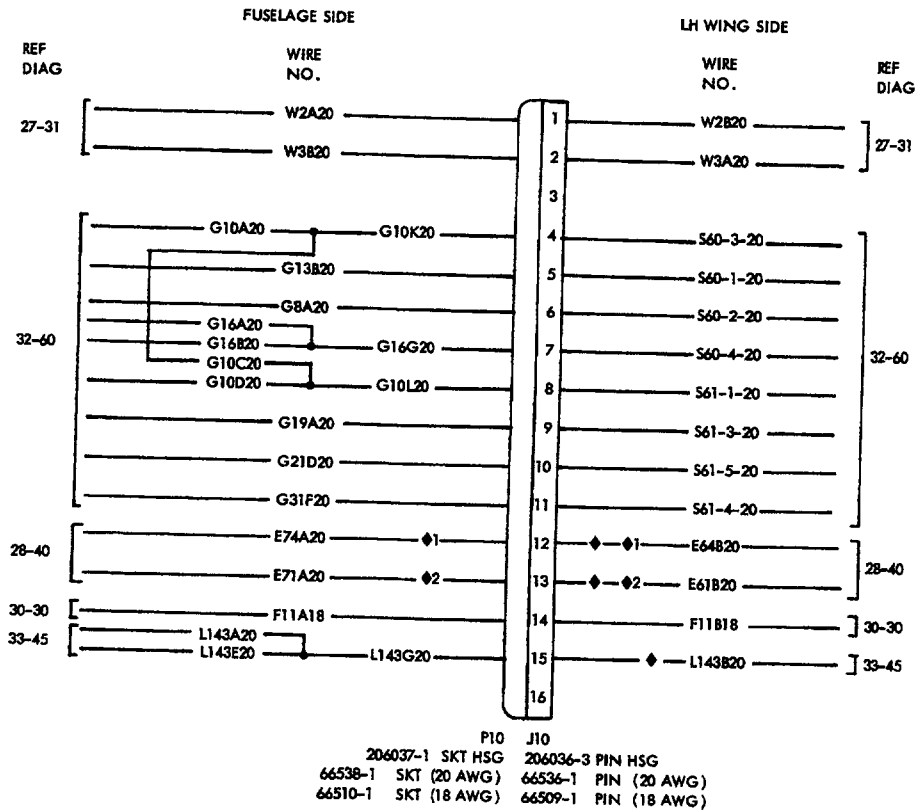

USE OF FOLLOWING TOOLS REQUIRED:

- INSERTION TOOL: 91002-1 (18 & 20 AWG)
- EXTRACTION TOOL: 305183 (18 & 20 AWG)
- CRIMPING TOOL: 90203-1 (18 & 20 AWG)
- STRAIN RELIEF: 206070-1 (AMP, INC)

- ◆ WIRE NUMBERS DUPLICATED ON CHART 91-13 FOR LEFT AND RIGHT WIRE HARNESS INTERCHANGEABILITY.
- ◆1 WIRE USED ON ACFT E-1836 & AFT, EA-213 THRU EA-272 EXCEPT EA-242, D-10370 & AFT, CJ-156 & AFT & CE-947 & AFT.
- ◆2 ON ACFT EA-213 & AFT, E-1836 & AFT, D-10370 & AFT, CJ-156 & AFT & CE-947 & AFT, WIRES E71A AND E61B REPLACE WIRES E50A AND E9C RESPECTIVELY.

CONNECTOR-WHEEL WELL ACCESS, LEFT WING (P/J10) (Configuration 1)

Beechcraft
BONANZA
WIRING DIAGRAM MANUAL

REFERENCE DESIGNATOR	PART NUMBER	DESCRIPTION	USABLE INSTL ON ZONE CODE
91-12-02 (Configuration 1)			
J10A	206036-3	RECEPTACLE-LEFT WHEEL WELL ACCESS	532 1
J10B	206070-1	STRAIN RELIEF	532 1
J10C	66103-2	PIN CONTACT (20 GAGE)	532 1
J10D	66099-2	PIN CONTACT (18 GAGE)	532 1
P10A	206037-1	PLUG-LEFT WHEEL WELL ACCESS	532 1
P10B	206070-1	STRAIN RELIEF CLAMP	532 1
P10C	66105-2	SOCKET CONTACT (20 GAGE)	532 1
P10D	66101-2	SOCKET CONTACT (18 GAGE)	532 1

EFFECTIVITY CODE

1. E-1371 THRU E-1945, E-1947 THRU E-2103, E-2105 THRU E-2110; CE-816 THRU CE-1300,
CE-1302 THRU CE-1306; CJ-150 THRU CJ-179; D-10179 AND AFTER; EA-1 THRU EA-319, EA-321
THRU EA-388

Beechcraft
BONANZA
WIRING DIAGRAM MANUAL

91-12-02

Configuration 2

CE-1301, CE-1307 AND AFTER; CJ-180 AND AFTER

Beechcraft BONANZA WIRING DIAGRAM MANUAL

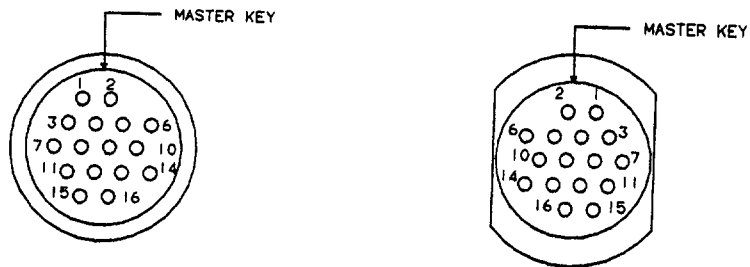

VIEW FROM BACK OF CONNECTORS

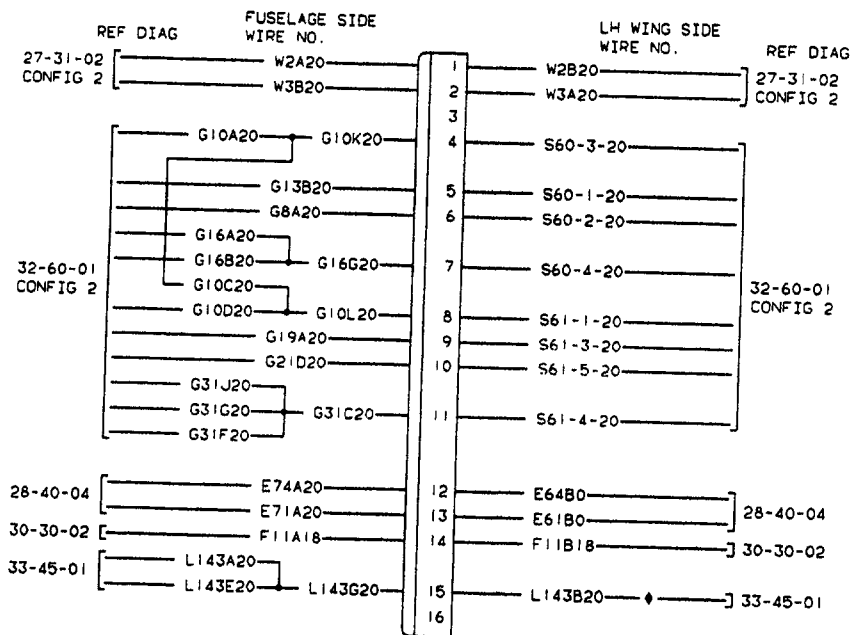

<p style="text-align: center;">P10</p> <p style="text-align: center;">206037-1 PLUG</p> <p>66105-2 SKT (20 AWG)</p> <p>66101-2 SKT (18 AWG)</p> <p>206070-1 STRAIN RELIEF</p>	<p style="text-align: center;">J10</p> <p style="text-align: center;">206036-3 RECEPTACLE</p> <p>66103-2 PIN (20 AWG)</p> <p>66099-2 PIN (18 AWG)</p> <p>206070-1 STRAIN RELIEF</p>
---	---

♦ WIRE NUMBERS DUPLICATED ON CHART
91-13 FOR LEFT AND RIGHT WIRE
HARNESS INTERCHANGEABILITY.

USE OF THE FOLLOWING TOOLS REQUIRED.
 INSERTION: 91002-1
 EXTRACTION: 305183
 CRIMP: 90203-1

CONNECTOR-WHEEL WELL ACCESS, LEFT WING (P/J10) (Configuration 2)

Beechcraft
BONANZA
WIRING DIAGRAM MANUAL

REFERENCE DESIGNATOR	PART NUMBER	DESCRIPTION	USABLE	
			INSTL	ON
			ZONE	CODE
91-12-02				
(Configuration 2)				
J10A	206036-3	RECEPTACLE-LEFT WHEEL WELL ACCESS	532	1
J10B	206070-1	STRAIN RELIEF	532	1
J10C	66103-2	PIN CONTACT (20 GAGE)	532	1
J10D	66099-2	PIN CONTACT (18 GAGE)	532	1
P10A	206037-1	PLUG-LEFT WHEEL WELL ACCESS	532	1
P10B	206070-1	STRAIN RELIEF CLAMP	532	1
P10C	66105-2	SOCKET CONTACT (20 GAGE)	532	1
P10D	66101-2	SOCKET CONTACT (18 GAGE)	532	1

EFFECTIVITY CODE

1. CE-1301, CE-1307 AND AFTER; CJ-180 AND AFTER

Beechcraft
BONANZA
WIRING DIAGRAM MANUAL

91-13-01

**E-1111, E-1241 THRU E-1945, E-1947 THRU E-2103, E-2105 THRU
E-2110; CE-748, CE-772 AND AFTER; CJ-149 AND AFTER; D-10097,
D-10120 AND AFTER; EA-1 THRU EA-319, EA-321 THRU EA-388**

Beechcraft BONANZA WIRING DIAGRAM MANUAL



VIEW FROM BACK OF CONNECTORS

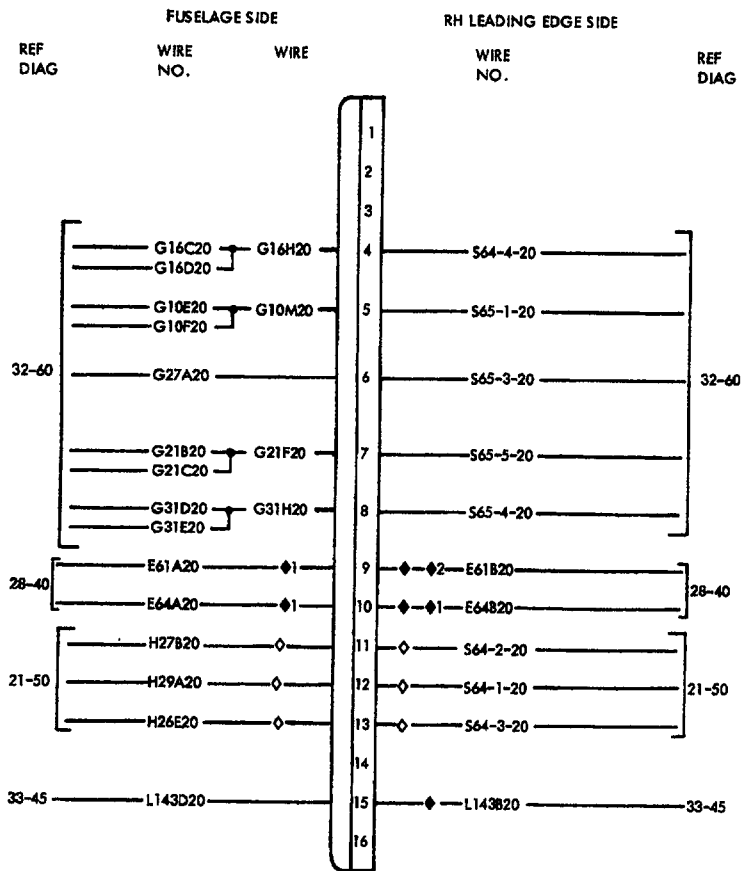

	P11	J11	
206037-1	SKT	SKT HSG	206036-3 PIN HSG
66538-1	SKT (20 AWG)		66536-1 PIN (20 AWG)
66510-1	SKT (18 AWG)		66509-1 PIN (18 AWG)

USE OF FOLLOWING TOOLS REQUIRED:

- INSERTION TOOL: 91002-1 (18 & 20 AWG)
- EXTRACTION TOOL: 305183 (18 & 20 AWG)
- CRIMPING TOOL: 90293-1 (18 & 20 AWG)
- STRAIN RELIEF: 206070-1 (AMP, INC.)

- ◆1 WIRE USED ON ACFT E-1836 & AFT, EA-213 THRU EA-272 EXCEPT EA-242, D-10370 & AFT, CJ-156 & AFT & CE-947 & AFT.
- ◆2 ON ACFT EA-213 & AFT, E-1836 & AFT, D-10370 & AFT, CJ-156 & AFT & CE-947 & AFT, WIRES E61A AND E61B REPLACE WIRES E51A AND E9C RESPECTIVELY.

◆ WIRE NUMBERS DUPLICATED ON CHART 91-12 FOR LEFT AND RIGHT WIRE HARNESS INTERCHANGEABILITY.

◇ ON ACFT EA-1 & AFT ONLY WIRES ARE NOT USED.

CONNECTOR-WHEEL WELL ACCESS, RIGHT WING (P/J11)

Beechcraft
BONANZA
WIRING DIAGRAM MANUAL

REFERENCE DESIGNATOR	PART NUMBER	DESCRIPTION	USABLE INSTL ON ZONE CODE
91-13-01			
J11A	206036-3	RECEPTACLE-RIGHT WHEEL WELL ACCESS	632 1
J11B	206070-1	STRAIN RELIEF	632 1
J11C	66103-2	PIN CONTACT (20 GAGE)	632 1
J11D	66099-2	PIN CONTACT (18 GAGE)	632 1
P11A	206037-1	PLUG-RIGHT WHEEL WELL ACCESS	632 1
P11B	206070-1	STRAIN RELIEF	632 1
P11C	66105-2	SOCKET CONTACT (20 GAGE)	632 1
P11D	66101-2	SOCKET CONTACT (18 GAGE)	632 1

EFFECTIVITY CODE

1. E-1111, E-1241 THRU E-1945, E-1947 THRU E-2103, E-2105 THRU E-2110; CE-748, CE-772 AND AFTER; CJ-149 AND AFTER; D-10097, D-10120 AND AFTER; EA-1 THRU EA-319, EA-321 THRU EA-388

Beechcraft
BONANZA
WIRING DIAGRAM MANUAL

91-15-01

**E-1111, E-1241 THRU E-1786; CE-748, CE-772 THRU CE-933; CJ-149
THRU CJ-155; D-10097, D-10120 THRU D-10357; EA-1 THRU EA-173**

Beechcraft BONANZA WIRING DIAGRAM MANUAL

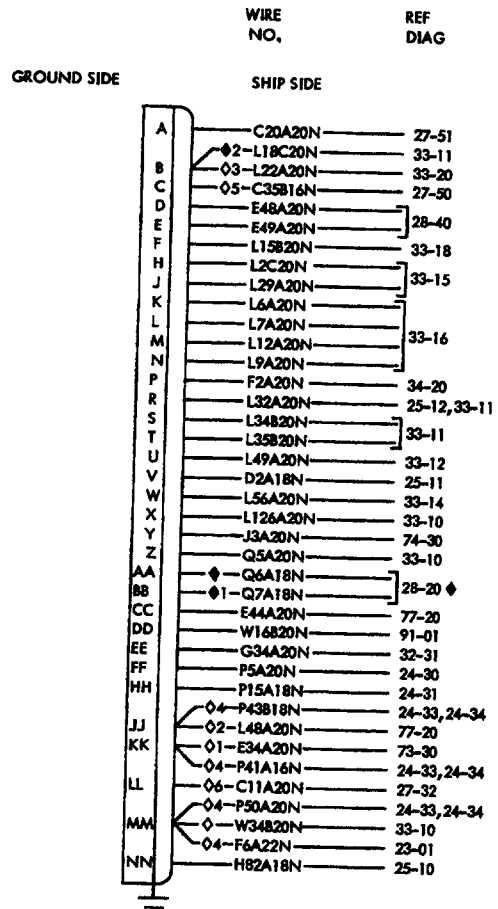
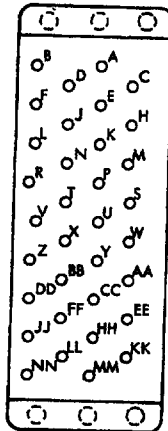

- ◆ ON ACFT E-1766 THRU E-1945, E-1947 THRU E-2103, E-2105 THRU E-2110; EA-159 THRU EA-319, EA-321 THRU EA-388; CE-919, CE-923, CE-925, CE-927, CE-929 & AFT; CJ-156 & AFT; D-10354 & AFT WIRE IS USED.
- ◆1 ON ACFT E-1766 THRU E-1945, E-1947 THRU E-2103, E-2105 THRU E-2110; EA-159 THRU EA-319, EA-321 THRU EA-388; CE-929 & AFT; CJ-156 & AFT; D-10354 & AFT WIRE IS USED.
- ◆2 ON ACFT E-1687 THRU E-1945, E-1947 THRU E-2103, E-2105 THRU E-2110; EA-71 THRU EA-319, EA-321 THRU EA-388; CE-902 & AFT; CJ-156 & AFT; D-10343 & AFT WIRE IS USED.
- ◆3 ON ACFT E-1422, E-1551, E-1569, E-1581, E-1594 THRU E-1945, E-1947 THRU E-2103, E-2105 THRU E-2110; EA-21, EA-26, EA-33 THRU EA-319, EA-321 THRU EA-388; CE-819, CE-923, CE-925, CE-927, CE-929 & AFT; CJ-156 & AFT; D-10348, D-10353 & AFT WIRE IS USED.
- ◆4 OPTIONAL WIRE - MAY TERMINATE AT ANY EMPTY PIN OF THIS CONNECTOR.
- ◆5 ON ACFT E-1111, E-1241 THRU E-1370; CE-748, CE-772 THRU CE-815, CJ-149, D-10097, D-10120 THRU D-10178 WIRE IS USED.
- ◆6 ON ACFT CE-748, CE-772 & AFT; CJ-149 & AFT, D-10097, D-10120 & AFT, WIRE IS USED.
- ◆ ON ACFT E-1111, E-1241 THRU E-1551, CE-748, CE-772 THRU CE-871, CJ-149 & CJ-150, D-10097, D-10120 THRU D-10268, WIRES ARE USED AS SHOWN.
- ◆1 ON ACFT CJ-149 & CJ-150 ONLY, WIRE USED AS SHOWN.
- ◆2 WIRE L18C MAY TERMINATE IN PIN B OR ANY OPEN PIN OF THIS CONNECTOR.

- J80 P80
 204814-1 200838-3 PLUG SOCKET HOUSING
 GROUNDING BLOCK 201580-1 SOCKET CONTACTS
 203616-1 JACKSCREW (MALE) (2)
 201224-1 STRAIN RELIEF CLAMP

USE OF FOLLOWING TOOLS REQUIRED:
 45099 (20 - 24 GAGE) (CRIMP)
 200893-2 (INSERTION)
 305183 (EXTRACTION)

CONNECTOR-INSTRUMENT PANEL GROUNDING (P/J80)

Beechcraft
BONANZA
WIRING DIAGRAM MANUAL

REFERENCE DESIGNATOR	PART NUMBER	DESCRIPTION	USABLE INSTL ON ZONE CODE
91-15-01			
J80	204814-1	RECEPTACLE-GROUNDING BLOCK, INSTRUMENT PANEL	231 1
P80A	200838-3	PLUG-GROUNDING BLOCK, INSTRUMENT PANEL	231 1
P80B	206618-1	JACKSCREW	231 1
P80C	201224-1	STRAIN RELIEF	231 1
P80D	201328-1	SOCKET CONTACT (20 GAGE)	231 1
P80E	200333-1	SOCKET CONTACT (16 OR 18 GAGE)	231 1

EFFECTIVITY CODE

1. E-1111, E-1241 THRU E-1786; CE-748, CE-772 THRU CE-933; CJ-149 THRU CJ-155; D-10097,
D-10120 THRU D-10357; EA-1 THRU EA-173

Beechcraft
BONANZA
WIRING DIAGRAM MANUAL

91-15-02

**E-1787 THRU E-1945, E-1947 THRU E-2103, E-2105 THRU E-2110;
CE-934 AND AFTER; CJ-156 AND AFTER; D-10358 AND AFTER;
EA-174 THRU EA-319, EA-321 THRU EA-388**

Beechcraft BONANZA WIRING DIAGRAM MANUAL

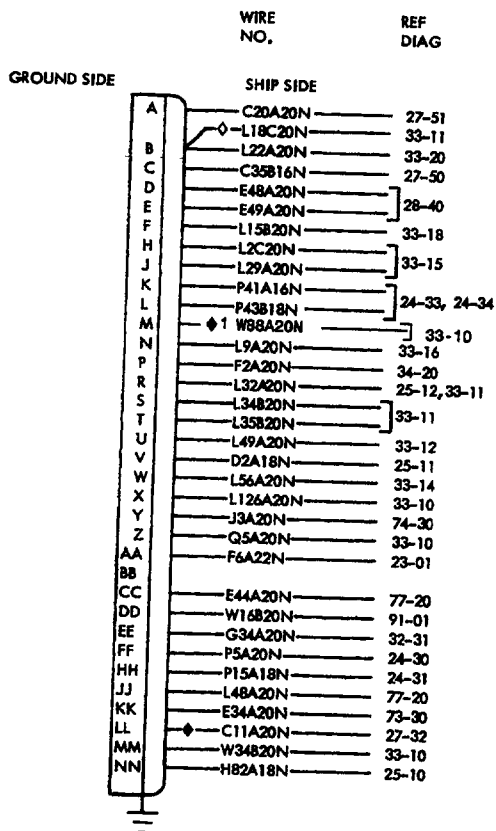
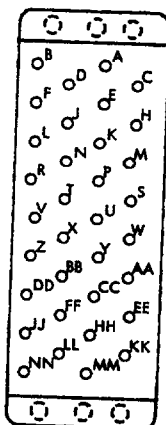

J80 P80
 204814-1 200838-3 PLUG SOCKET HOUSING
 GROUNDING BLOCK 201580-1 SOCKET CONTACTS
 203618-1 JACKSCREW (MALE) (2)
 201244-1 STRAIN RELIEF CLAMP

USE OF FOLLOWING TOOLS REQUIRED:

45099 (20 - 24 GAGE) (CRIMP)
 200893-2 (INSERTION)
 305183 (EXTRACTION)

◆ 1 ON AIRCRAFT CE-1056 & AFTER, CJ-156 & AFTER, & D-10404 & AFTER, WIRE IS USED

◆ USED ON ACFT CE934 & AFT, CJ-156 & AFT, D-10358 & AFT.

◆ WIRE L18C MAY TERMINATE IN PIN B OR ANY OPEN PIN OF THIS CONN THRU ACFT E-1790; EA-177; CE-934; CJ-155; D-10359.

CONNECTOR-INSTRUMENT PANEL GROUNDING (P/J80)

Beechcraft
BONANZA
WIRING DIAGRAM MANUAL

REFERENCE DESIGNATOR	PART NUMBER	DESCRIPTION	USABLE INSTL ON ZONE CODE	
91-15-02				
J80	204814-1	RECEPTACLE-GROUNDING BLOCK, INSTRUMENT PANEL	231	1
P80A	200838-3	PLUG-GROUNDING BLOCK, INSTRUMENT PANEL	231	1
P80B	206618-1	JACKSCREW	231	1
P80C	201224-1	STRAIN RELIEF	231	1
P80D	201328-1	SOCKET CONTACT (20 GAGE)	231	1
P80E	200333-1	SOCKET CONTACT (16 OR 18 GAGE)	231	1

EFFECTIVITY CODE

1. E-1787 THRU E-1945, E-1947 THRU E-2103, E-2105 THRU E-2110; CE-934 AND AFTER; CJ-156 AND AFTER; D-10358 AND AFTER; EA-174 THRU EA-319, EA-321 THRU EA-388

Beechcraft
BONANZA
WIRING DIAGRAM MANUAL

91-19-01

**E-1111, E-1241 THRU E-1370; CE-748, CE-772 THRU CE-815; D-10097,
D-10120 THRU D-10178; EA-1 ONLY**

Beechcraft BONANZA WIRING DIAGRAM MANUAL

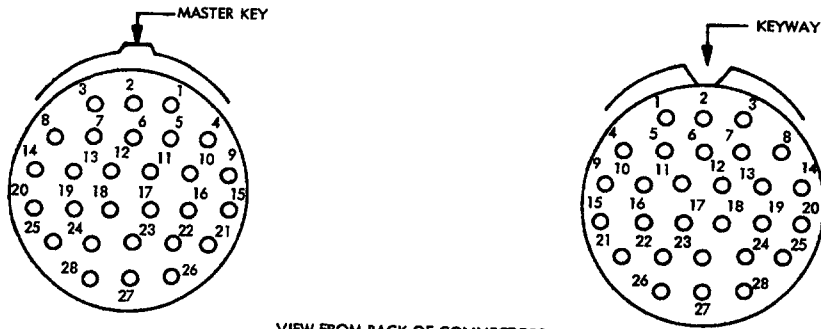

VIEW FROM BACK OF CONNECTORS

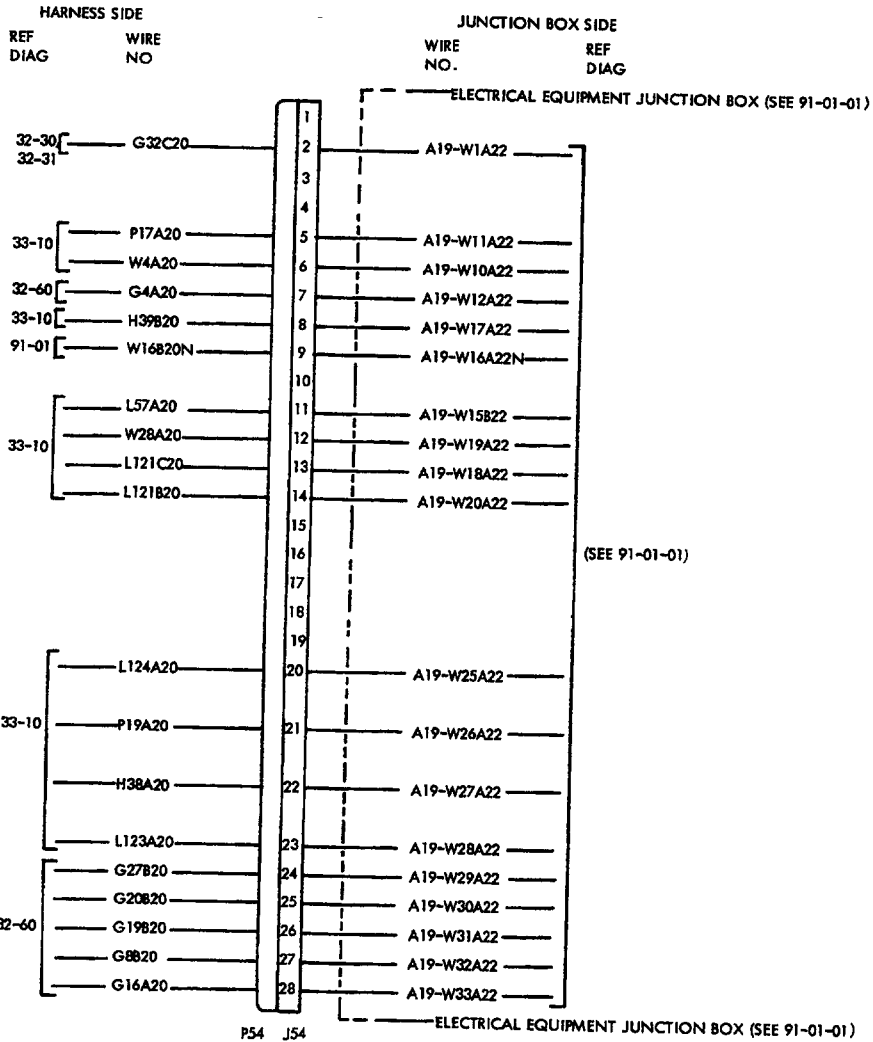

USE OF FOLLOWING TOOLS REQUIRED:
 INSERTION AND EXTRACTION TOOL 91067-2 (20-24 AWG).
 CRIMP TOOL 90265-1 (20-24 AWG).
 STRAIN RELIEF 206070-1 (AMP, INC).

JUNCTION BOX DISCONNECT (P/J54)

Beechcraft
BONANZA
WIRING DIAGRAM MANUAL

REFERENCE DESIGNATOR	PART NUMBER	DESCRIPTION	USABLE	
			INSTL ZONE	ON CODE
91-19-01				
J54A	206152-1	RECEPTACLE-JUNCTION BOX ASSEMBLY	231	1
J54B	205089-1	SOCKET CONTACT (22 GAGE)	231	1
P54A	205839-3	PLUG-JUNCTION BOX ASSEMBLY	231	1
P54B	205090-1	SOCKET CONTACT (20 GAGE)	231	1

EFFECTIVITY CODE

1. E-1111, E-1241 THRU E-1370; CE-748, CE-772 THRU CE-815; D-10097, D-10120 THRU D-10178;
EA-1 ONLY

Beechcraft
BONANZA
WIRING DIAGRAM MANUAL

91-19-02

**E-1371 THRU E-1765; CE-816 THRU CE-918, CE-920 THRU CE-922,
CE-924, CE-926, CE-928; CJ-149 THRU CJ-155; D-10179 THRU
D-10353; EA-2 THRU EA-158**

Beechcraft BONANZA WIRING DIAGRAM MANUAL

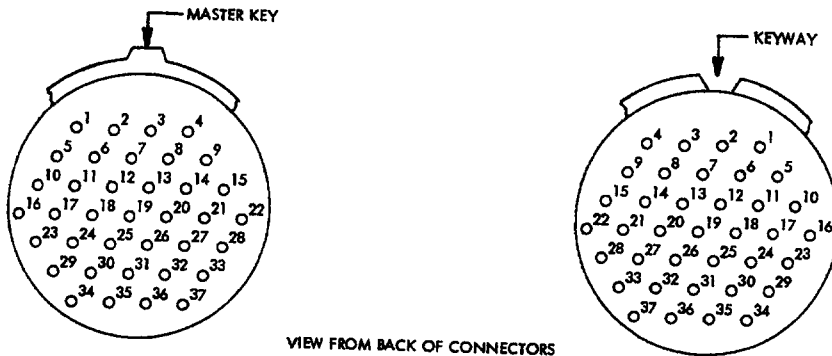

VIEW FROM BACK OF CONNECTORS

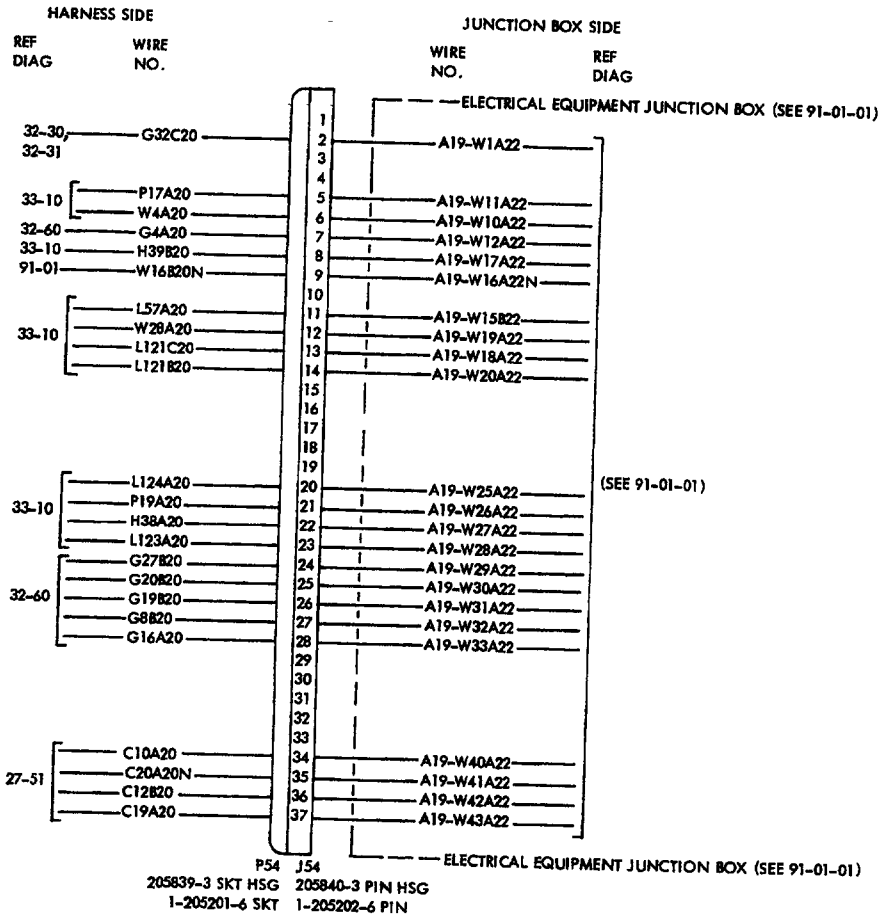

USE OF FOLLOWING TOOLS REQUIRED:
 INSERTION AND EXTRACTION TOOL 91067-2 (20-24 AWG).
 CRIMP TOOL 90265-1 (20-24 AWG).
 STRAIN RELIEF 206070-1 (AMP, INC).

JUNCTION BOX DISCONNECT (P/J54)

Beechcraft
BONANZA
WIRING DIAGRAM MANUAL

REFERENCE DESIGNATOR	PART NUMBER	DESCRIPTION	USABLE	
			INSTL	ON ZONE CODE
91-19-02				
J54A	205840-3	RECEPTACLE-ELECTRICAL EQUIPMENT JUNCTION BOX ASSEMBLY	231	1
J54B	1-205202-6	PIN CONTACT	231	1
J54C	206070-1	STRAIN RELIEF CLAMP	231	1
P54A	205839-3	PLUG-ELECTRICAL EQUIPMENT JUNCTION BOX ASSEMBLY	231	1
P54B	1-205201-6	SOCKET CONTACT	231	1
P54C	206070-1	STRAIN RELIEF CLAMP	231	1

EFFECTIVITY CODE

1. E-1371 THRU E-1765; CE-816 THRU CE-918, CE-920 THRU CE-922, CE-924, CE-926, CE-928;
 CJ-149 THRU CJ-155; D-10179 THRU D-10353; EA-2 THRU EA-158

Beechcraft
BONANZA
WIRING DIAGRAM MANUAL

91-19-03

Configuration 1

**E-1766 THRU E-1945, E-1947 THRU E-2103, E-2105 THRU E-2110;
CE-919, CE-923, CE-925, CE-927, CE-929 THRU CE-1300, CE-1302
THRU CE-1306; CJ-156 THRU CJ-179; D-10354 AND AFTER; EA-159
THRU EA-319, EA-321 THRU EA-388**

Beechcraft BONANZA WIRING DIAGRAM MANUAL

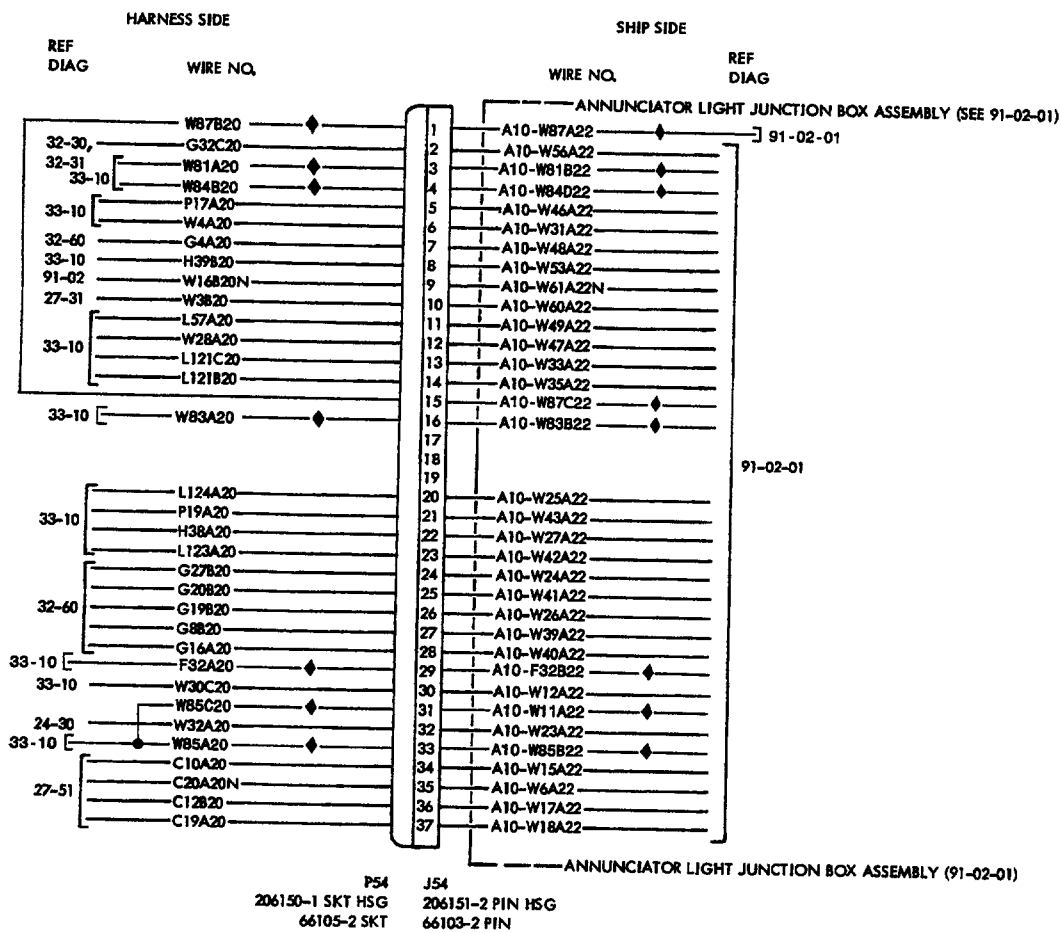
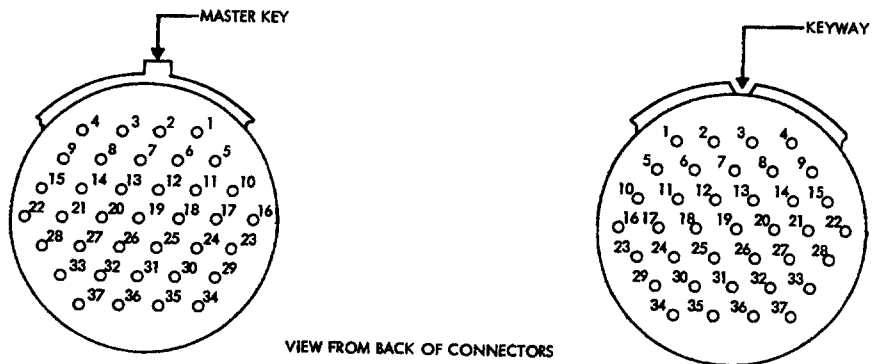

USE OF FOLLOWING TOOLS REQUIRED:
 INSERTION AND EXTRACTION TOOL 91067-2 (20-24 AWG)
 CRIMP TOOL 90265-1 (20-24 AWG).
 STRAIN RELIEF 206070-1 (AMP, INC).

◆ ON AIRCRAFT CE-1056 THRU CE-1300,
 CE-1302 THRU CE-1306, CJ-156 THRU
 CJ-179, D-10404 & AFT, WIRE IS USED

JUNCTION BOX DISCONNECT (P/J54) (Configuration 1)

Beechcraft
BONANZA
WIRING DIAGRAM MANUAL

REFERENCE DESIGNATOR	PART NUMBER	DESCRIPTION	USABLE INSTL ON ZONE CODE	
91-19-03 (Configuration 1)				
J54A	206151-2	RECEPTACLE-ANNUNCIATOR LIGHT JUNCTION BOX ASSEMBLY	231	1
J54B	66103-2	PIN CONTACT	231	1
J54C	206138-1	STRAIN RELIEF CLAMP	231	1
P54A	206150-1	PLUG-ANNUNCIATOR LIGHT JUNCTION BOX ASSEMBLY	231	1
P54B	66105-2	SOCKET CONTACT	231	1
P54C	206138-1	STRAIN RELIEF CLAMP	231	1

EFFECTIVITY CODE

1. E-1766 THRU E-1945, E-1947 THRU E-2103, E-2105 THRU E-2110; CE-919, CE-923, CE-925, CE-927, CE-929 THRU CE-1300, CE-1302 THRU CE-1306; CJ-156 AND AFTER; D-10354 AND AFTER; EA-159 THRU EA-319, EA-321 THRU EA-388

Beechcraft
BONANZA
WIRING DIAGRAM MANUAL

91-19-03

Configuration 2

CE-1301, CE-1307 AND AFTER; CJ-180 AND AFTER

Beechcraft BONANZA WIRING DIAGRAM MANUAL

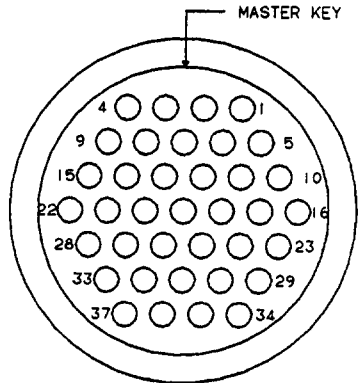

VIEW FROM BACK OF CONNECTORS

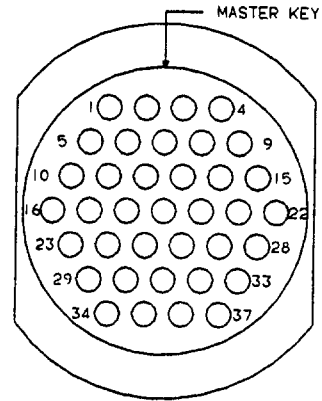
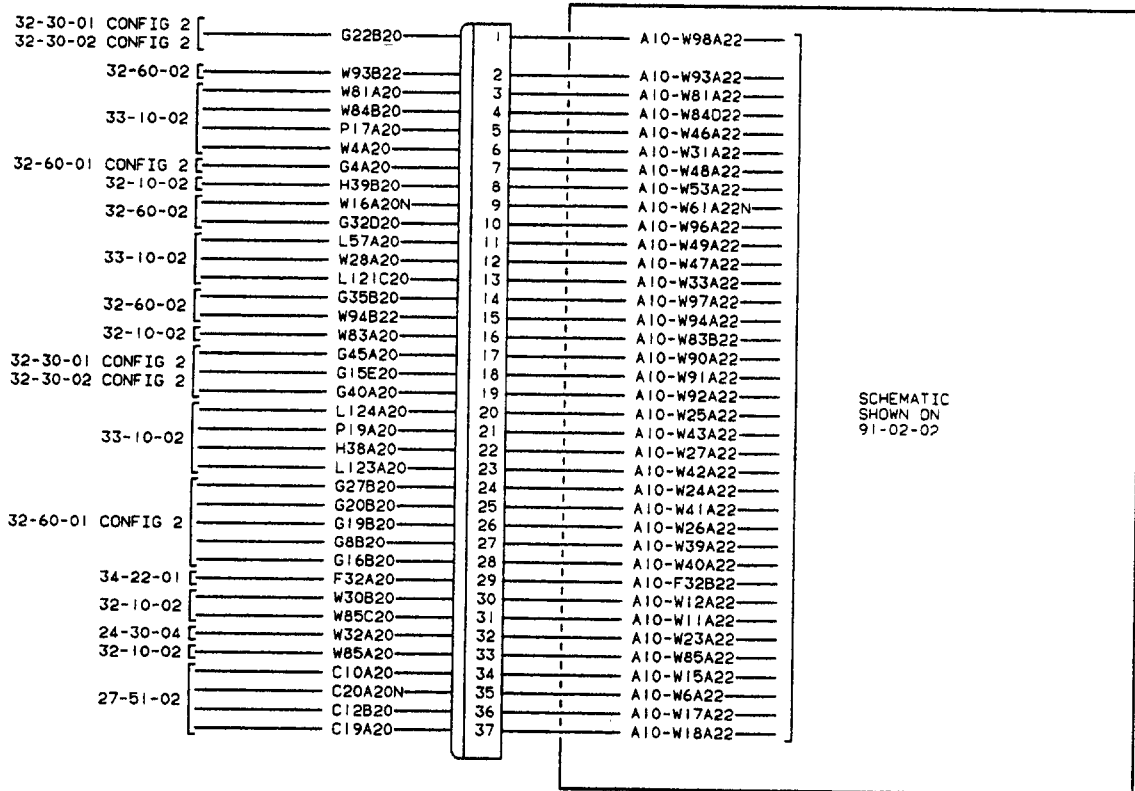

DIAGRAM REF HARNESS SIDE
WIRE NO.

SHIP SIDE
WIRE NO. DIAGRAM REF



A10 ANNUNCIATOR LIGHT JUNCTION BOX ASSEMBLY

P54
206150-1 PLUG
66105-2 SOCKET CONTACT
206070-1 CABLE CLAMP

J54
206070-1 CABLE CLAMP
66103-2 PIN CONTACT
206151-2 RECEPTACLE

JUNCTION BOX DISCONNECT (P/J54) (Configuration 2)

Beechcraft
BONANZA
WIRING DIAGRAM MANUAL

REFERENCE DESIGNATOR	PART NUMBER	DESCRIPTION	USABLE	
			INSTL ZONE	ON CODE
91-19-03 (Configuration 2)				
J54A	206151-2	RECEPTACLE-ANNUNCIATOR LIGHT JUNCTION BOX ASSEMBLY	231	1
J54B	66103-2	PIN CONTACT	231	1
J54C	206138-1	STRAIN RELIEF CLAMP	231	1
P54A	206150-1	PLUG-ANNUNCIATOR LIGHT JUNCTION BOX ASSEMBLY	231	1
P54B	66105-2	SOCKET CONTACT	231	1
P54C	206138-1	STRAIN RELIEF CLAMP	231	1

EFFECTIVITY CODE

1. CE-1301, CE-1307 AND AFTER; CJ-180 AND AFTER

Beechcraft
BONANZA
WIRING DIAGRAM MANUAL

91-21-01

Configuration 1

**E-1111, E-1241 THRU E-1945, E-1947 THRU E-2103, E-2105 THRU
E-2110; CE-748, CE-772 THRU CE-1300, CE-1302 THRU CE-1306;
CJ-149 THRU CJ-179; D-10097, D-10120 AND AFTER; EA-1 THRU
EA-319, EA-321 THRU EA-388**

Beechcraft BONANZA WIRING DIAGRAM MANUAL

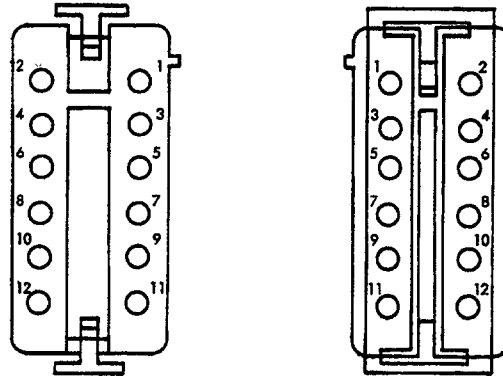

VIEW FROM BACK OF CONNECTOR

HARNES SIDE

PANEL SIDE

REF DIAG	WIRE NO.	WIRE NO.	REF DIAG
----------	----------	----------	----------

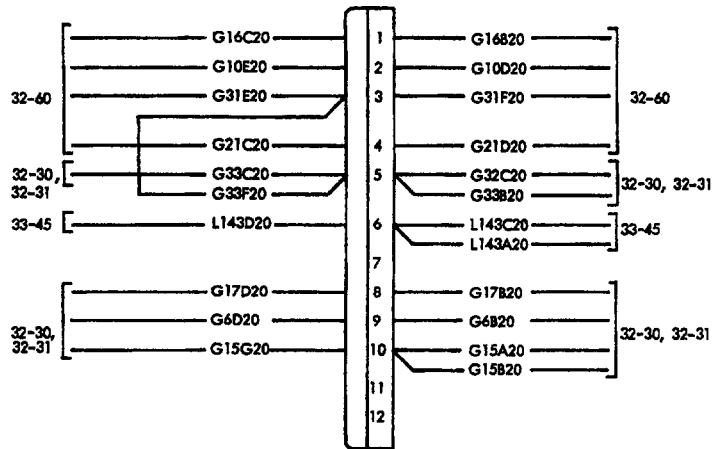

PBS	J85
1-480287-0 SKT HSG	1-480288-0 PIN HSG
60617-1 SKT (QTY 8)	60618-1 PIN (QTY 8)
61108-1 SKT (QTY 1)	61109-1 PIN (QTY 1)

USE OF FOLLOWING TOOLS REQUIRED:
 INSERTION 91002-1
 EXTRACTION 1-305183-1 PINS & 1-305183-2 SOCKETS
 CRIMP TOOL: 90123-2
 90123-1

CROSSOVER DISCONNECT (P/J85) (Configuration 1)

Beechcraft
BONANZA
WIRING DIAGRAM MANUAL

REFERENCE DESIGNATOR	PART NUMBER	DESCRIPTION	USABLE INSTL ON ZONE CODE
91-21-01 (Configuration 1)			
J85A	1-480288-0	RECEPTACLE-CROSSOVER DISCONNECT	150 1
J85B	60618-1	PIN CONTACT (20 GAGE)	150 1
P85A	1-480287-0	PLUG-CROSSOVER DISCONNECT	150 1
P85B	60617-1	SOCKET CONTACT (20 GAGE)	150 1

EFFECTIVITY CODE

1. E-1111, E-1241 THRU E-1945, E-1947 THRU E-2103, E-2105 THRU E-2110; CE-748, CE-772 THRU CE-1300, CE-1302 THRU CE-1306; CJ-149 THRU CJ-179; D-10097, D-10120 AND AFTER; EA-1 THRU EA-319, EA-321 THRU EA- 388

Beechcraft
BONANZA
WIRING DIAGRAM MANUAL

91-21-01

Configuration 2

CE-1301, CE-1307 AND AFTER; CJ-180 AND AFTER

Beechcraft BONANZA WIRING DIAGRAM MANUAL

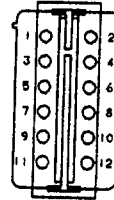
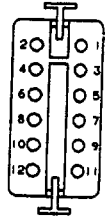

VIEW FROM BACK OF CONNECTORS

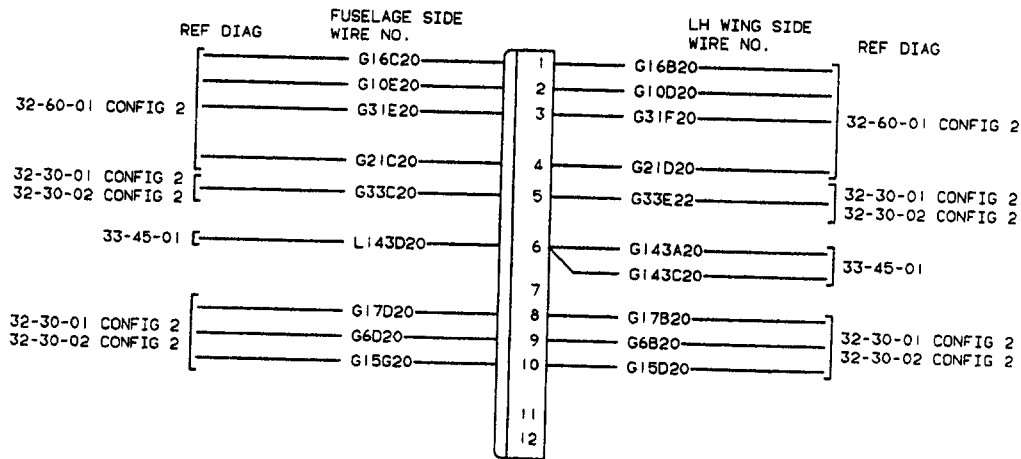

<p style="text-align: center;">P85</p> <p style="text-align: center;">1-480287-0 SKT HSG 60617-1 SKT (20AWG) 61108-1 SKT (2/20AWG)</p>	<p style="text-align: center;">J85</p> <p style="text-align: center;">1-480288-0 PIN HSG 60618-1 PIN (20 AWG) 61109-1 PIN (2/20AWG)</p>
--	---

USE OF THE FOLLOWING TOOLS REQUIRED.
 INSERTION: 91002-1
 EXTRACTION: 1-305183-1 PIN CONTACT
 1-305183-2 SKT CONTACT
 CRIMP: 90123-1 & 90123-2

CROSSOVER DISCONNECT (P/J85) (Configuration 2)

Beechcraft
BONANZA
WIRING DIAGRAM MANUAL

REFERENCE DESIGNATOR	PART NUMBER	DESCRIPTION	USABLE	
			INSTL	ON ZONE CODE
91-21-01 (Configuration 2)				
J85A	1-480288-0	RECEPTACLE-CROSSOVER DISCONNECT	150	1
J85B	60618-1	PIN CONTACT (20 GAGE)	150	1
P85A	1-480287-0	PLUG-CROSSOVER DISCONNECT	150	1
P85B	60617-1	SOCKET CONTACT (20 GAGE)	150	1

EFFECTIVITY CODE

1. CE-1301, CE-1307 AND AFTER; CJ-180 AND AFTER

Beechcraft
BONANZA
WIRING DIAGRAM MANUAL

91-22-01

CE-1301, CE-1307 AND AFTER; CJ-180 AND AFTER

Beechcraft BONANZA WIRING DIAGRAM MANUAL

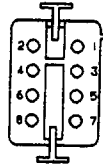

VIEW FROM BACK OF CONNECTORS

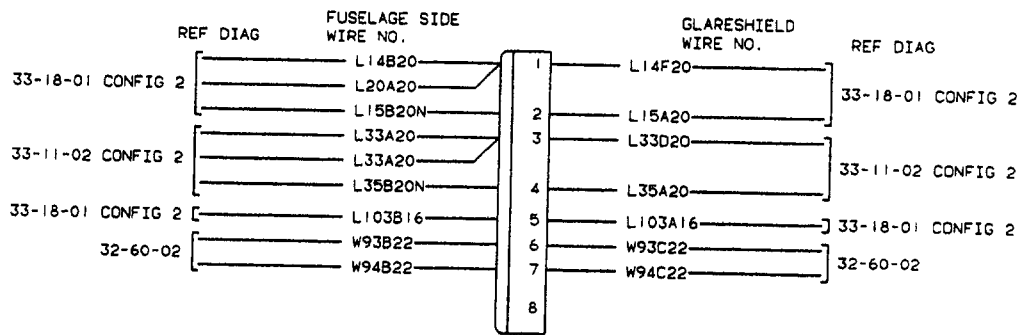

<p style="text-align: center;">P31</p> <p>1-480283-0 SKT HSG 60617-1 SKT (20AWG) 61108-1 SKT (2/20AWG)</p>	<p style="text-align: center;">J31</p> <p>1-480345-0 PIN HSG 60618-1 PIN (20 AWG)</p>
--	---

USE OF THE FOLLOWING TOOLS REQUIRED.
 INSERTION: 91002-1
 EXTRACTION: 1-305183-1 PIN CONTACT
 1-305183-2 SKT CONTACT
 CRIMP: 90123-1 & 90123-2

CONNECTOR-GLARESHIELD (P/J31)

Beechcraft
BONANZA
WIRING DIAGRAM MANUAL

REFERENCE DESIGNATOR	PART NUMBER	DESCRIPTION	USABLE	
			INSTL ZONE	ON CODE
91-22-01				
J31A	1-480340	RECEPTACLE-GLARESHIELD	231	1
J31B	1-480345-0	PIN HOUSING	231	1
J31C	60618-1	PIN CONTACT	231	1
P31A	1-480270-0	PLUG-GLARESHIELD	231	1
P31B	1-480283-0	SOCKET HOUSING	231	1
P31C	60617-1	SOCKET CONTACT	231	1

EFFECTIVITY CODE

1. CE-1301, CE-1307 AND AFTER; CJ-180 AND AFTER