

Courtesy of Bomar Flying Service  
[www.bomar.biz](http://www.bomar.biz)



# **SUPER CUB**

**PARTS CATALOG**

**CARD 1 OF 1**

**PA-18-150**

# **PIPER AIRCRAFT CORPORATION**

**(PART NUMBER 761 823)**

---

# PIPER PARTS CATALOG

---

## AEROFICHE EXPLANATION AND REVISION STATUS

The parts catalog information in this set of Aerofiche cards is arranged in accordance with general specifications of Aerofiche adopted by the General Aviation Manufacturer's Association

Conversion of Aerofiche alpha/numeric code numbers:

First number is the Aerofiche card identifier

Letter is the horizontal line reference per card

Second number is the vertical line reference per card

Example: 2J16 = Aerofiche card number two of given set, grid location J16

A Table of Contents is located at grid 1A8

## REVISIONS

The information in this Aerofiche Parts Catalog is kept current by revisions distributed periodically. These revisions supersede all previous revisions, are complete Aerofiche card replacements, and supersede Aerofiche cards of the same number in the set.

Revisions to this PA-18-150 Super Cub Parts Catalog (761 823) issued June 27, 1988 are as follows

Effectivity	Publication Date	Aerofiche Card Effectivity
ORG880627	August 15, 1988	1

NOTE Consult the Customer Service Information Aerofiche for current revision dates for this manual

# INTRODUCTION

This illustrated parts catalog provides simple but positive identification of replacement parts for the Piper Super Cub PA-18-150, manufactured by Piper Aircraft Corporation of Vero Beach, Florida

— WARNING —

Do not use this catalog for rigging or installation purposes

- 1 The catalog is divided into eleven major sections as follows:
  - a Sections I to X inclusive contain all replacement parts for the complete airplane. Each section is subdivided and each division includes an illustration and a parts listing.
  - b Section XI is the Miscellaneous Group. This group includes a listing of the Optional Equipment Kits.
- 2 The following is a brief explanation of the columns in the parts listing:
  - a The FIGURE AND INDEX column indicates the illustration figure number and its parts index number. Example: (2-1), the 2 is the figure number and the 1 is the index number. The figure number appears only at the top of each parts listing page or at the beginning of each new parts listing.
  - b The PART NUMBER column contains the identifying number of the replacement part. This number must be shown on all parts orders.
  - c The CODE column indicates special uses of the part. An explanation of the letter code is shown on the CODE EXPLANATIONS page.
  - d The NOMENCLATURE column indicates the part name. This name must be shown on all parts orders.
  - e The NO REQ column represents the total quantity of parts used per aircraft per figure when the part is not indented and the quantity of parts used per assembly when the part is indented. The symbol AR listed in this column means "As Required".
  - f The SERIAL NUMBERS AFFECTED column indicates the part application by airplane serial number.

Figure and Index Number	Part Number	Code	EXAMPLE NOMENCLATURE	No. Req.	SERIAL NUMBERS AFFECTED
			DOOR ASSEMBLY - Baggage compartment	1	
			* FRAME ASSEMBLY - Baggage compartment door	1	
			* * HINGE ASSEMBLY - Baggage door	1	
			* * CLIP - Baggage door spring	1	

This listing is interpreted as follows:

If the DOOR ASSEMBLY (not indented) is ordered, it will include the three items listed under DOOR ASSEMBLY.

If the FRAME ASSEMBLY (indented one space) is ordered, it will include the two items listed under FRAME ASSEMBLY.

If you want only a HINGE ASSEMBLY or CLIP, you order only that item.

- 3 Optional equipment items are contained in the parts list in their proper sequence and sections. These items are not marked optional, since they are fully identified by their descriptions.

---

# PIPER PARTS CATALOG

---

## HOW TO IDENTIFY A PART IF YOU KNOW WHAT IT LOOKS LIKE AND KNOW WHERE IT IS LOCATED

- 1 Refer to Figure 1 to determine the section number in which the part is located
- 2 Refer to the Table of Contents and locate the section. Note the figure numbers that illustrate the various subgroups of this main section. Select the figure title you think might contain the part you wish to identify and turn to the grid (page) specified
- 3 Find the part on the illustration and note the index number  
  
NOTE: If you don't find the part on this illustration, try another figure in this group
- 4 Refer to the "Figure and Index Number" in the parts listing for complete description of the part

## HOW TO ORDER PARTS

When ordering parts, please observe the following instructions:

- 1 Place your order with your local distributor or service center
- 2 Specify the model and serial number of your airplane
- 3 Specify part number, name, type and quantity required
- 4 Specify the method of shipment - freight, express, parcel post, air express, air freight or air parcel post. Where the nature of the shipment requires it or when no instructions are given, we reserve the right to ship the most suitable way
- 5 Request price and delivery information prior to order placement.

## GENERAL INFORMATION

- 1 **Shortages**  
All orders are checked before leaving our shipping department. A packing slip is enclosed with the shipment. Claims for errors or shortages must be made within three days after receipt of orders
- 2 **Returned Goods**  
Please do not return material to us without securing our written permission. Material returned to us without notice will be held at the owner's risk for thirty days and will then be disposed of as we see fit  
  
NOTE: Transportation charges must be prepaid on returned goods or the shipment will be refused
- 3 **Transportation Liabilities**  
The Piper Aircraft Corporation cannot be held liable for damages to parts in transit from the factory. If a shipment is received in a damaged condition, have the delivery man or transportation company make a notation of the damage and file your claim with the carrier. In case of concealed damage, do not attempt to remove the part from the shipping container, or try to repair the damage. Call the carrier and have their claim agent inspect the damage before filing your claim with the carrier

---

# PIPER PARTS CATALOG

## PA-18-150 SERIAL NUMBER INFORMATION

Serial numbers of the aircraft covered in this parts catalog are as follows:

PA-18-150 Super Cub serial numbers 1809001 and up.

---

# PIPER PARTS CATALOG

---

## CECONITE 7600 PROCESS FINISH MATERIALS

— NOTE —

The Piper PA-18-150 Super Cub is manufactured using the Blue River Ceconite 7600 Aircraft Covering Process. All finish products listed below are used only in this process.

PIPER PART NUMBER

Flexi-Gloss Finish, Cub Yellow .....	170 880 (Gallon)
Flexi-Gloss Finish, White .....	170 879 (Gallon)
Flexi-Gloss Finish, Black .....	170 881 (Quart)
Flexi-Gloss Finish, Clear .....	170 882 (Gallon)
Activator (7603GL) .....	179 714 (Gallon)
Activator (7603QT) .....	170 715 (Quart)
Cement (7602GL) .....	180 004 (Gallon)
Cement (7602QT) .....	180 005 (Quart)
Cleaner (CL1GL) .....	279 049 (Gallon)
Filler (7601GL) .....	460 987 (Gallon)
Tape - Pinked, 2" wide (76P2) .....	180 470 (50 yard)
Tape - Pinked, 3" wide (76P3) .....	180 471 (25 yard)
Tape - Pinked, 4" wide (76P4) .....	180 472 (25 yard)
Tape - Cloth, multi-purpose, 1" wide .....	180 474 (60 feet)
Tape - Reinforcing, 1/4" wide (RT14) .....	180 475 (60 yard)
Tape - Reinforcing, 1/2" wide (RT12) .....	180 473 (60 yard)

**THIS PAGE INTENTIONALLY LEFT BLANK**

# TABLE OF CONTENTS

FIGURE NUMBER	FIGURE TITLE	GRID NUMBER
1	Ceconite 7600 Process Finish Materials .....	1A6
	Exploded View of Complete Airplane .....	1A11
SECTION I WING GROUP		
2	Wing and Fuel Tank Installation .....	1A12
3	Covered Wing Assembly .....	1A16
4	Wing Panel Assembly, Uncovered (Showing Leading Edge) .....	1A20
5	Wing Panel Assembly, Uncovered (Showing Trailing Edge) .....	1A24
6	Flap Assembly .....	1B5
7	Aileron Assembly .....	1B8
8	Strut Installation .....	1B11
SECTION II FUSELAGE GROUP		
9	Covered Fuselage Assembly, Left View .....	1B14
10	Covered Fuselage Assembly, Right View .....	1B18
11	Fuselage Frame Assembly .....	1B21
12	Seats Installation .....	1C1
13	Rudder Pedals and Floorboards Installation .....	1C4
14	Throttle, Cabin and Carburetor Heat Mixture Controls .....	1C7
15	Instrument Panel Installation (Standard) .....	1C10
16	Instrument Panel Installation (With Options) .....	1C14
SECTION III AGRICULTURAL GROUP		
.....		
SECTION IV TAIL GROUP		
17	Tail Surface Installation .....	1C18
SECTION V CHASSIS GROUP		
18	Landing Gear Installation .....	1C22
19	Brake Assembly (Cleveland) .....	1D2
20	Main Wheel Assembly (Cleveland) .....	1D5
21	Tail Wheel Installation .....	1D8
22	Brake Installation .....	1D11
SECTION VI POWERPLANT GROUP		
23	Powerplant Installation, Lycoming .....	1D14
24	Spinner Installation .....	1D19
25	Cowl Installation, Lycoming .....	1D22
26	Baffles Installation .....	1E1
27	Vacuum System Installation .....	1E4



# TABLE OF CONTENTS

FIGURE NUMBER	FIGURE TITLE	GRID NUMBER
SECTION VII FUEL SYSTEM GROUP		
28	Fuel System Installation.....	1E8
SECTION VIII ELECTRICAL SYSTEM GROUP		
29	Electrical System Installation .....	1E12
30	Electrical Components Installation .....	1E16
31	Wing Light and Strobe Light Installation.....	1E19
32	Landing Light Installation .....	1E22
33	Electric Fuel Gauge Installation .....	1F1
34	Speaker and Dome Light Installation .....	1F4
SECTION IX CONTROL SYSTEM GROUP		
35	Elevator and Aileron Control Installation.....	1F7
36	Elevator Control System.....	1F10
37	Aileron Control System .....	1F13
38	Rudder Control System .....	1F16
39	Flap Control System .....	1F19
40	Adjustment Stabilizer Control System .....	1F23
41	Stabilizer Adjustment Crank Installation.....	1G2
42	Stabilizer Adjustment Yoke and Bungee Installation .....	1G5
SECTION X RADIO GROUP		
43	Piper Automatic Locator (ELT) Installation (Narco Avionics).....	1G8
SECTION XI MISCELLANEOUS GROUP		
	Optional Equipment Kits .....	1G12

---

**PIPER PARTS CATALOG**

---

**THIS PAGE INTENTIONALLY LEFT BLANK**

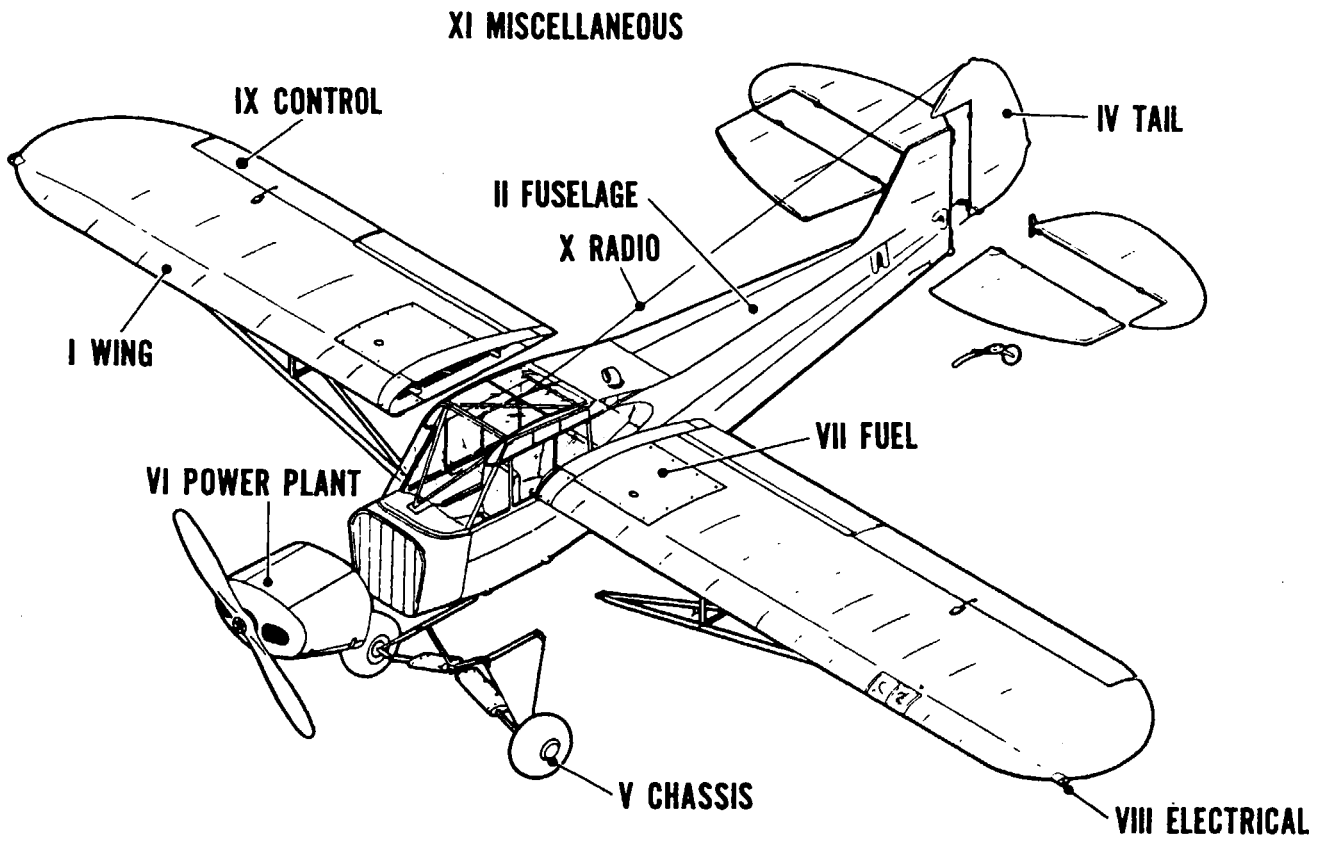

Figure 1 Exploded View of Complete Airplane

# PIPER PARTS CATALOG

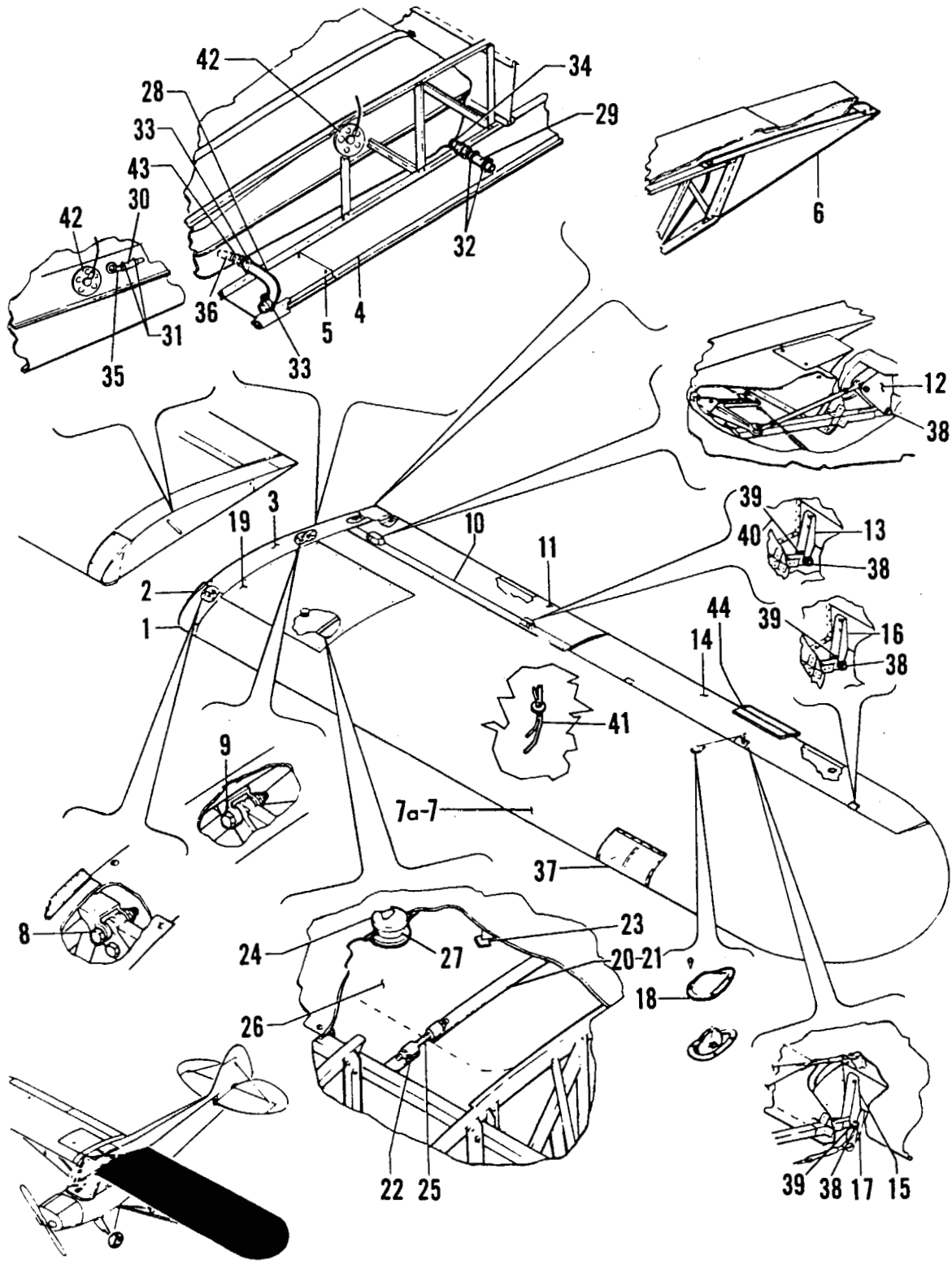

Figure 2 Wing and Fuel Tank Installation

---

# PIPER PARTS CATALOG

CODE EXPLANATIONS FOR FIGURE 2

## PIPER PARTS CATALOG

Figure and Index Number	Part Number	Code	NOMENCLATURE	No. Req.	SERIAL NUMBERS AFFECTED
2-	12322 13766 14477		DRAWING - Rigging Diagram DRAWING - Wing and Fuel Tank Installation DRAWING - Aircraft Dimension and Control Surface Travel		
-1	12276-00 12276-01		FAIRING - Wing Root, LH FAIRING - Wing Root, RH	1 1	
-2	19657-00		MOULDING - Rubber	2	
-3	11523-00		FAIRING - Wing Root, top	2	
-4	12274-00 12274-02		FAIRING - Wing Root, bottom front, LH FAIRING - Wing Root, bottom front, RH	1 1	
-5	12275-00 12275-01		FAIRING - Wing Root, bottom rear, LH FAIRING - Wing Root, bottom rear, RH	1 1	
-6	11719-00 11719-01		PLATE - Fairing attachment, LH PLATE - Fairing attachment, RH	1 1	
-7	14400-04 14400-05		PANEL ASSEMBLY - Wing, Ceconite covered, LH PANEL ASSEMBLY - Wing, Ceconite covered, RH	1 1	
-7a	459 131		ENVELOPE - Wing, Ceconite, left or right (BLU PA-18-W)	1 2	
-8	401 195 407 566 404 889		BOLT - (AN5-17A) WASHER - (AN960-515) NUT - (MS20365-524C)	2 2 2	
-9	401 194 407 566 404 889		BOLT - (AN5-16A) WASHER - (AN960-516) NUT - (MS20365-524C)	2 4 2	
-10	12795-00 12795-01		FAIRING - Flap, LH FAIRING - Flap, RH	1 1	
-11	60709-02 60709-03		FLAP ASSEMBLY - Aluminum, Left FLAP ASSEMBLY - Aluminum, Right	1 1	
-12	11682-00		HINGE - Flap, inboard	1	
-13	41881-02		HINGE - Flap, outboard	1	
-14	60714-02 60714-03		AILERON ASSEMBLY - Aluminum, left AILERON ASSEMBLY - Aluminum, right	1 1	
-15	41891-00		HINGE - Center	1	
-16	41881-00		HINGE - Inboard and outboard	2	
-17	40501-00		HORN ASSEMBLY	1	
-18	60752-00		COVER - Pulley	2	
-19	12570-09 12570-09		COVER ASSEMBLY - Fuel tank, LH COVER ASSEMBLY - Fuel tank, RH (reversed)	1 1	
-20	10016-20		FELT - Top (4-per ship)	2	
-21	10016-21		FELT - Bottom (4-per ship)	2	
-22	10016-17		FELT - Front (4-per ship)	2	
-23	180 497		FELT - SAE F-50 tank cover (10 ft per ship)	5	
-24	60750-02		CAP - Tank (fuel cap assembly)	2	
-25	80111-00		STUD - Tank strap (4-per ship)	2	
-26	10849-34 10849-43		TANK ASSEMBLY - Fuel, LH TANK ASSEMBLY - Fuel, RH	1 1	
-27	74181-00		* FLANGE - Fuel tank filler cap	2	
-28	82371-10		HOSE, Flexible	2	
-29	82371-07		HOSE, Flexible	1	
-30	82371-06		HOSE, Flexible	1	
-31	454 983		CLAMP, (#8 SAE Type "E" Zinc plated)	2	
-32	554 778		CLAMP, (SAE TY F GS4SS)	2	

When ordering, always specify Part Number, Description, and Serial Number of Aircraft

## PIPER PARTS CATALOG

Figure and Index Number	Part Number	Code	NOMENCLATURE	No. Req.	SERIAL NUMBERS AFFECTED
2-33	554 871		CLAMP, (SAE TY F GS6SS)	4	
-34	460 649		FITTING - CONNECTOR - W/H # 234 x 4	1	
-35	458 940		ELBOW - (AN-840-4D)	1	
-36	72091-00		STRAINER ASSEMBLY - Tank outlet	2	
-37	12532-03		WINDOW - Landing light	1	
-38	424 217		PIN - Hinge, aileron and flap (AN394-41)	10	
-39	407 565		WASHER - (AN960-416)	AR	
-40	407 585		WASHER - (AN960-416L)	AR	
-41	13764-00		TUBE ASSEMBLY - Airspeed (pitot/static)	1	
-42	60762-02		GAUGE ASSEMBLY - Sender	2	
-43	476 652		NIPPLE - (AN 840-6D)	4	
-44	11253-00		TAB - Aileron trim	2	

When ordering, always specify Part Number, Description, and Serial Number of Aircraft

PIPER PARTS CATALOG

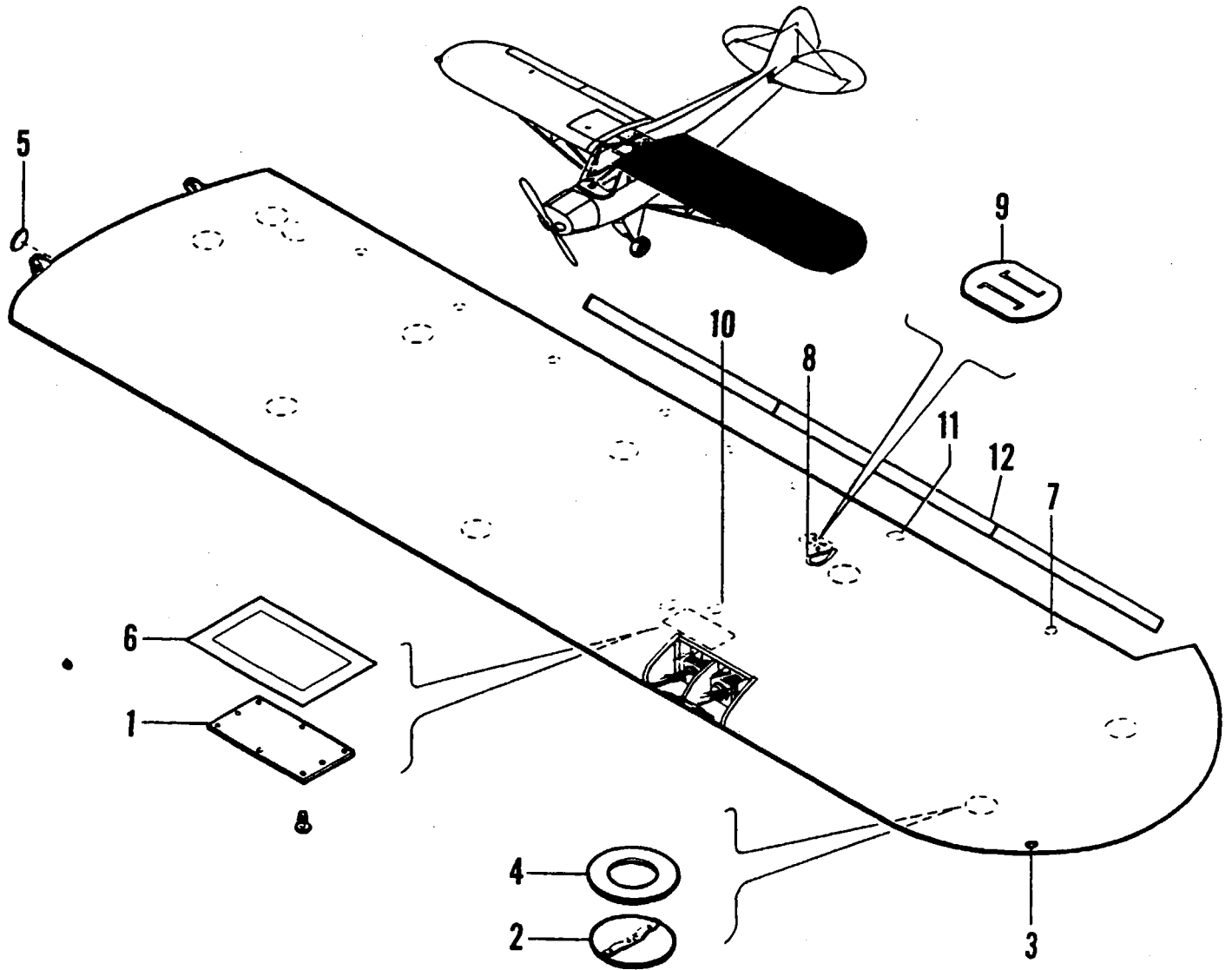

Figure 3 Covered Wing Assembly



---

# PIPER PARTS CATALOG

CODE EXPLANATIONS FOR FIGURE 3

PIPER PARTS CATALOG

Figure and Index Number	Part Number	Code	NOMENCLATURE	No. Req.	SERIAL NUMBERS AFFECTED
3-	14400		DRAWING - Wing Assembly, Covered		
-1	82461-00		WINDOW - Wing inspection	AR	
-2	12761-02		COVER ASSEMBLY - Drag wire inspection	AR	
-3	81232-15		DISC - Pyralin, jig hole cover	8	
-4	85012-78		GROMMET - Round	AR	
-5	80122-51		GROMMET - Reinforcing, pyralin	AR	
-6	80541-02		GROMMET - Cover	AR	
-7	80122-53		GROMMET - Drain	AR	
-8	60671-00		GROMMET - Aileron pulley cover	2	
-9	15761-00		REINFORCEMENT - Pyralin	4	
-10	60863-03		REINFORCEMENT - Leather	7	
-11	60863-09		REINFORCEMENT - Leather	2	
-12	11473-47		PLATE - Reinforcing	6	

When ordering, always specify Part Number, Description, and Serial Number of Aircraft

---

**PIPER PARTS CATALOG**

**THIS PAGE INTENTIONALLY LEFT BLANK**

PIPER PARTS CATALOG

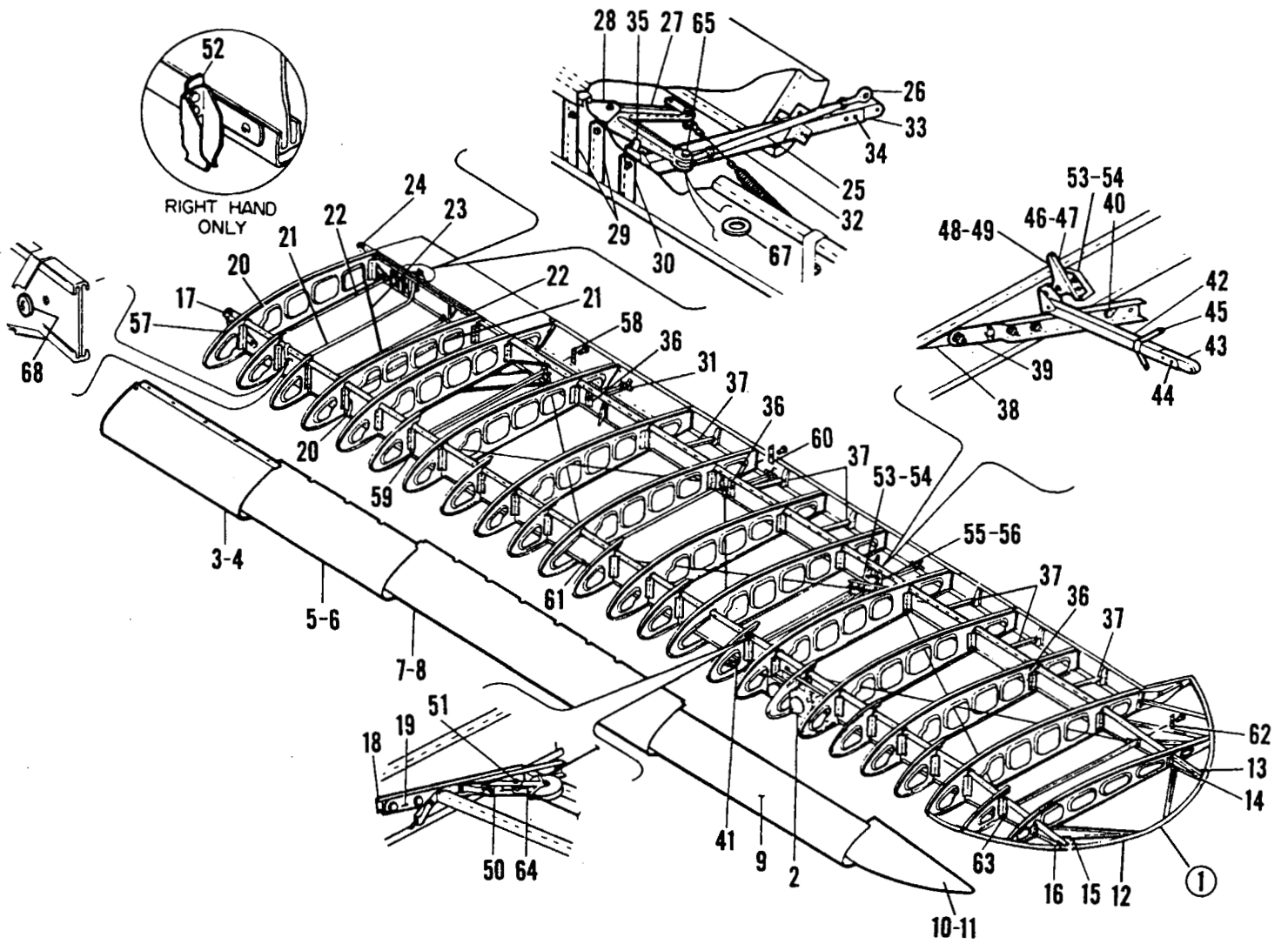

Figure 4 Wing Panel Assembly, Uncovered (Showing Leading Edge)

---

# PIPER PARTS CATALOG

CODE EXPLANATIONS FOR FIGURE 4

## PIPER PARTS CATALOG

Figure and Index Number	Part Number	Code	NOMENCLATURE	No. Req.	SERIAL NUMBERS AFFECTED
4-	14394		DRAWING - Wing panel assembly, uncovered		
-1	14394-02		WING PANEL ASSEMBLY - Uncovered LH	1	
	14394-03		WING PANEL ASSEMBLY - Uncovered RH	1	
-2	472 661		LIGHT - Landing (4509)	2	
-3	10630-05		COVER - Leading edge inboard RH #1	2	
-4	10630-08		COVER - Leading edge inboard LH #1	2	
-5	14387-00		COVER - Leading edge center inboard section LH #2	1	
-6	14387-01		COVER - Leading edge center inboard section RH #2	1	
7	14389-00		COVER - Leading edge center outboard section LH #3	1	
-8	14389-01		COVER - Leading edge center outboard section RH #3	1	
-9	13072-06		COVER - Leading edge outboard #4	2	
-10	15723-00		COVER - Tip, leading edge, LH	1	
-11	15723-01		COVER - Tip, leading edge, RH	1	
-12	453 126		BOW - Wing tip	2	
-13	16611-00		FITTING - Wing tip bow rear spar	2	
-14	16601-00		FITTING - Wing tip bow rear spar	2	
-15	16551-00		FITTING - Wing tip bow front spar	2	
-16	16561-00		FITTING - Wing tip bow front spar	2	
-17	10401-00		FITTING - Front spar butt hinge	4	
-18	14461-00		BLOCK - Filler	4	
-19	14192-00		FITTING ASSEMBLY - Left strut attachment	4	
-20	10648-03		STRAP ASSEMBLY - Fuel tank	2	
-21	10650-02		STRAP ASSEMBLY - Fuel tank	2	
-22	10649-03		STRAP ASSEMBLY - Fuel tank	2	
-23	10641-00		TUBE - Drag brace, fuel tank	1	
-24	14161-00		FITTING - Hinge rear spar butt	4	
-25	11677-00		ROD - Push pull flap	2	
-26	452 335		BEARING - Push pull rod	2	
-27	40092-10		BELLCRANK	2	
-28	11672-00		BRACKET - Flap bellcrank	2	
-29	11675-02		ANGLE - Reinforcement	4	
-30	11675-03		ANGLE - Reinforcement	2	
-31	10703-04		BRACKET ASSEMBLY - Flap hinge	2	
-32	10703-03		BRACKET ASSEMBLY - Flap hinge	2	
-33	10921-00		BLOCK - Bearing	4	
-34	422 604		RIVET - Steel (1/8" x 15/16" L)	8	
-35	11678-00		PLATE - Stop	4	
-36	10291-00		ANGLE - Reinforcement inboard aileron hinge, outboard aileron hinge, and outboard flap hinge	6	
-37	89232-02		BRACE ASSEMBLY - False spar	12	
-38	14271-00		BLOCK - Filler	4	
-39	14182-00		FITTING - Lift strut attachment	4	
-40	15631-03		SPACER	2	
-41	15631-02		SPACER	2	
-42	10703-00		BRACKET ASSEMBLY - Aileron hinge	6	
-43	10921-00		BLOCK	1	
-44	422 604		RIVET - Steel (1/8" x 15/16" L)	2	
-45	14581-00		STOP ASSEMBLY - Aileron	2	
-46	14611-00		BRACKET - Aileron pulley, inboard half, LH	1	
-47	14611-01		BRACKET - Aileron pulley, inboard half, RH	1	
-48	14621-00		BRACKET - Aileron pulley, outboard half, LH	1	

When ordering, always specify Part Number, Description, and Serial Number of Aircraft

## PIPER PARTS CATALOG

Figure and Index Number	Part Number	Code	NOMENCLATURE	No. Req.	SERIAL NUMBERS AFFECTED
4-49	14621-01		BRACKET - Aileron pulley, outboard half, RH	1	
-50	14261-00		BRACKET - Aileron pulley housing attachment	2	
-51	82732-24		BUSHING	2	
-52	12847-00		BRACKET ASSEMBLY - Door catch mounting	1	
-53	14571-00		ANGLE - Reinforcement, pulley bracket, LH	1	
-54	14571-01		ANGLE - Reinforcement, pulley bracket, RH	1	
-55	14291-00		ANGLE - Reinforcement, center aileron hinge, LH	1	
-56	14291-01		ANGLE - Reinforcement, center aileron hinge, RH	1	
-57	14401-08		ANGLE - Reinforcement, No 1 drag strut	2	
-58	14411-02		ANGLE - Reinforcement, No 2 drag strut	2	
-59	14401-03		ANGLE - Reinforcement, No 2 drag strut	2	
-60	14411-03		ANGLE - Reinforcement, No 3 drag strut	2	
-61	14401-04		ANGLE - Reinforcement, No 3 drag strut	2	
-62	14411-04		ANGLE - Reinforcement, No 5 drag strut	2	
-63	14401-05		ANGLE - Reinforcement, No 5 drag strut	2	
-64	41291-00		HOUSING - Pulley	2	
-65	400 443		BOLT - Flap bellcrank to push pull rod (AN3-12A)	2	
-66	12028-00		CHANNEL - Reinforcement	2	
-67	407 564		WASHER - Spacer, flap control rod installation at bellcrank (AN960-10)	4	
-68	80122-11		WASHER - Fuel tank strap attachment	16	

When ordering, always specify Part Number, Description, and Serial Number of Aircraft

# PIPER PARTS CATALOG

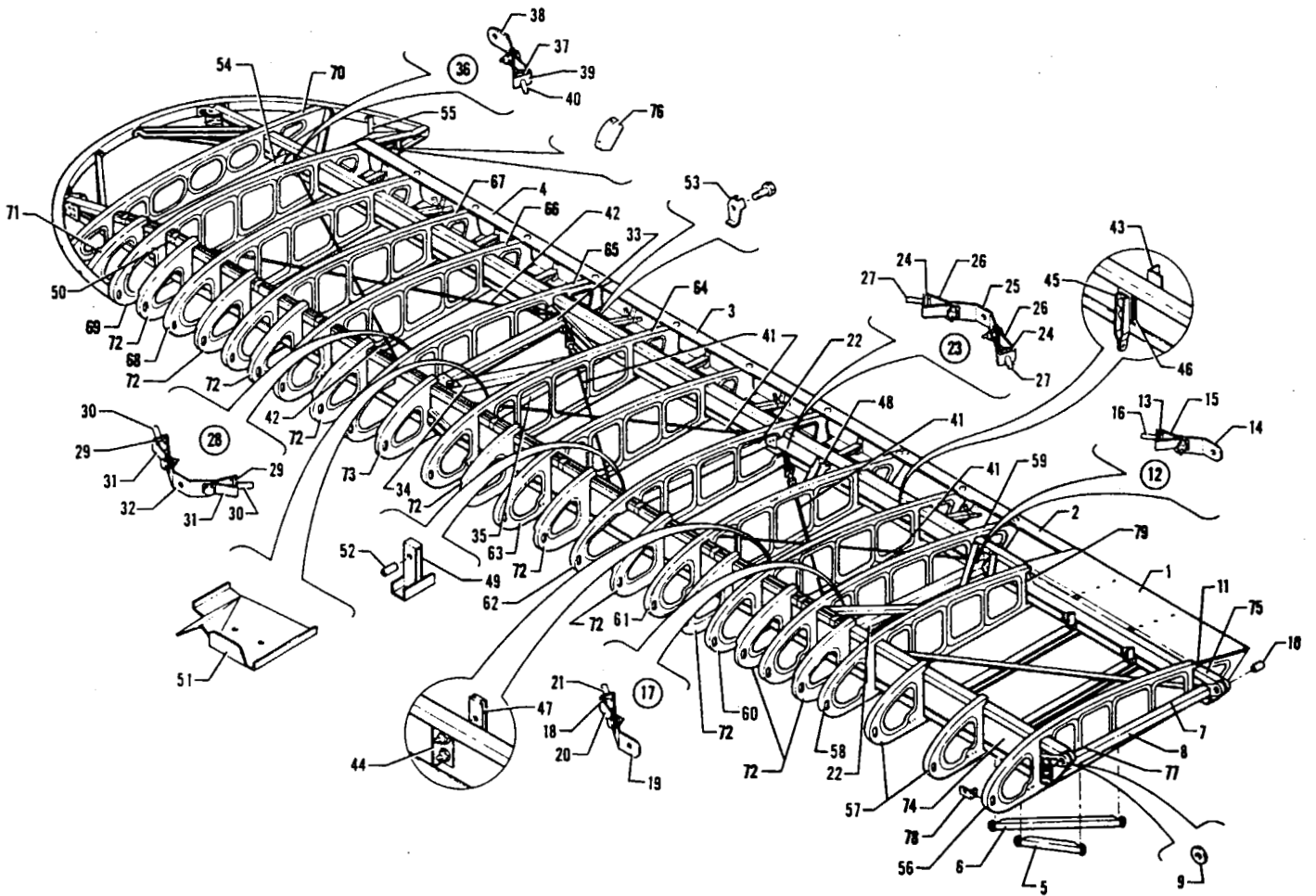

Figure 5 Wing Panel Assembly, Uncovered (Showing Trailing Edge)



---

# PIPER PARTS CATALOG

---

CODE EXPLANATIONS FOR FIGURE 5

PIPER PARTS CATALOG

Figure and Index Number	Part Number	Code	NOMENCLATURE	No. Req.	SERIAL NUMBERS AFFECTED
5-	14394		DRAWING - Wing Panel Assembly, Uncovered		
-1	14385-00		SPAR - False, flap inboard, left	1	
	14385-01		SPAR - False, flap inboard, right	1	
-2	11670-06		SPAR - False, flap outboard, left	1	
	11670-07		SPAR - False, flap outboard, right	1	
-3	14382-04		SPAR - False, aileron inboard, left	1	
	14382-05		SPAR - False, aileron inboard, right	1	
-4	15572-04		SPAR - False, aileron outboard, left	1	
	15572-05		SPAR - False, aileron outboard, right	1	
-5	12252-02		BRACE - Channel (8 5" L)	8	
-6	12252-03		BRACE - Channel (16 0" L)	16	
-7	12252-06		BRACE - Channel (6 25" L)	2	
-8	14232-02		STRUT - Drag, No 1	2	
-9	80122-25		WASHER	2	
-10	80022-31		BUSHING - Insert	6	
-11	10171-04		FITTING - Attachment, brace tube	2	
-12	10705-00		FITTING ASSEMBLY - Drag wire pull, rear spar, No 2 drag strut	2	
-13	81102-03		*WASHER - Square	1	
-14	10171-04		*FITTING	1	
-15	10221-00		*CLEVIS	1	
-16	10201-00		*NIPPLE	1	
-17	10711-00		FITTING ASSEMBLY - Drag wire pull, front spar No 2 drag strut	2	
-18	81102-03		*WASHER - Square	1	
-19	10161-04		*FITTING	1	
-20	10221-00		*CLEVIS	1	
-21	10201-00		*NIPPLE	1	
-22	14222-02		STRUT ASSEMBLY - Drag, No 2 and No 3	4	
-23	10706-00		FITTING ASSEMBLY - Drag wire pull, front and rear spar, No 3 drag strut	4	
-24	81102-03		*WASHER - Square	2	
-25	10161-04		*FITTING	1	
-26	10221-00		*CLEVIS	3	
-27	10201-00		*NIPPLE	2	
-28	10707-00		FITTING ASSEMBLY - Drag wire pull, "N" brace, front and rear spar, No 4 drag strut	4	
-29	81102-03		*WASHER - Square	2	
-30	10201-00		*NIPPLE	2	
-31	10221-00		*CLEVIS	2	
-32	10161-05		*FITTING	1	
-33	16462-00		TUBE ASSEMBLY - Drag strut, upper "N"	2	
-34	10112-07		TUBE - Drag strut, "N" brace	2	
-35	16472-00		TUBE ASSEMBLY - Drag strut, lower "N"	2	
-36	10709-00		FITTING ASSEMBLY - Drag wire pull, front and rear spar, No 5 drag strut	4	
-37	81102-03		*WASHER - Square	1	
-38	10171-05		*FITTING - Wire pull	1	
-39	10221-00		*CLEVIS	1	
-40	10201-00		*NIPPLE	1	
-41	14941-06		WIRE - Drag, No 2 and No 3 bay (44 875" L)	8	
-42	14941-07		WIRE - Drag, No 4 bay (56 25" L)	4	
-43	14361-02		ANGLE - Rear spar	2	
-44	14361-03		ANGLE - Front spar	2	

When ordering, always specify Part Number, Description, and Serial Number of Aircraft

**PIPER PARTS CATALOG**

Figure and Index Number	Part Number	Code	NOMENCLATURE	No. Req.	SERIAL NUMBERS AFFECTED
5-45	12581-00		FITTING - Front and rear spar, Jury strut	4	
-46	14371-02		BLOCK - Filler, rear spar	2	
-47	14371-03		BLOCK - Filler, front spar	2	
-48	11580-00		BRACKET - Airspeed, left	1	
-49	10644-00		BRACKET ASSEMBLY - Pulley	2	
-50	11061-00		CLIP - Navigation light wire	22	
-51	10531-04		FORMER - Fabric, "N" brace assembly, left	1	
	10531-05		FORMER - Fabric, "N" brace assembly, right	1	
-52	80012-03		BUSHING - Insert, pulley	1	
-53	10151-00		PLATE - Lock	24	
-54	14222-00		STRUT - Drag No. 5	2	
-55	12252-05		BRACE - Channel (11" L)	2	
-56	89192-04		RIB ASSEMBLY - No 1 butt, left	1	
	89192-05		RIB ASSEMBLY - No 1 butt, right	1	
-57	89190-04		RIB ASSEMBLY - No 2 and 3, left	2	
	89190-05		RIB ASSEMBLY - No 2 and 3, right	2	
-58	89193-04		RIB ASSEMBLY - No 4, left	1	
	89193-05		RIB ASSEMBLY - No 4, right	1	
-59	89195-04		RIB ASSEMBLY - No 5, left	1	
	89195-05		RIB ASSEMBLY - No 5, right	1	
-60	89195-06		RIB ASSEMBLY - No 6, left	1	
	89195-07		RIB ASSEMBLY - No 6, right	1	
-61	89195-08		RIB ASSEMBLY - No 7, left	1	
	89195-09		RIB ASSEMBLY - No 7, right	1	
-62	89196-02		RIB ASSEMBLY - No 8, left	1	
	89196-03		RIB ASSEMBLY - No 8, right	1	
-63	89195-10		RIB ASSEMBLY - No 9, left	1	
	89195-11		RIB ASSEMBLY - No 9, right	1	
-64	89195-10		RIB ASSEMBLY - No 10, left	1	
	89195-11		RIB ASSEMBLY - No 10, right	1	
-65	89196-02		RIB ASSEMBLY - No 11, left	1	
	89196-03		RIB ASSEMBLY - No 11, right	1	
-66	89195-10		RIB ASSEMBLY - No 12, left	1	
	89195-11		RIB ASSEMBLY - No 12, right	1	
-67	89195-10		RIB ASSEMBLY - No 13, left	1	
	89195-11		RIB ASSEMBLY - No 13, right	1	
-68	89195-10		RIB ASSEMBLY - No 14, left	1	
	89195-11		RIB ASSEMBLY - No 14, right	1	
-69	89195-12		RIB ASSEMBLY - No 15, left	1	
	89195-13		RIB ASSEMBLY - No. 15, right	1	
-70	89191-02		RIB ASSEMBLY - No 16, left tip	1	
	89191-03		RIB ASSEMBLY - No 16, right tip	1	
-71	89215-02		RIB - Nose, tip, left	1	
	89215-03		RIB - Nose, tip, right	1	
-72	15831-02		RIB ASSEMBLY - Nose, left and right	20	
-73	15831-05		RIB ASSEMBLY - Nose, No 6, left and right	2	
-74	14391-04		SPAR ASSEMBLY - Front, left	1	
	14391-05		SPAR ASSEMBLY - Front, right	1	
-75	14392-04		SPAR ASSEMBLY - Rear, left	1	
	14392-05		SPAR ASSEMBLY - Rear, right	1	
-76	13171-00		GUSSET - False spar	2	
-77	11151-02		PLATE - "U", fairlead retainer	4	
-78	12331-02		PLATE - Butt rib and leading edge attachment	2	
-79	16141-00		BRACE - Wing rib	AR	

When ordering, always specify Part Number, Description, and Serial Number of Aircraft

---

**PIPER PARTS CATALOG**

**THIS PAGE INTENTIONALLY LEFT BLANK**

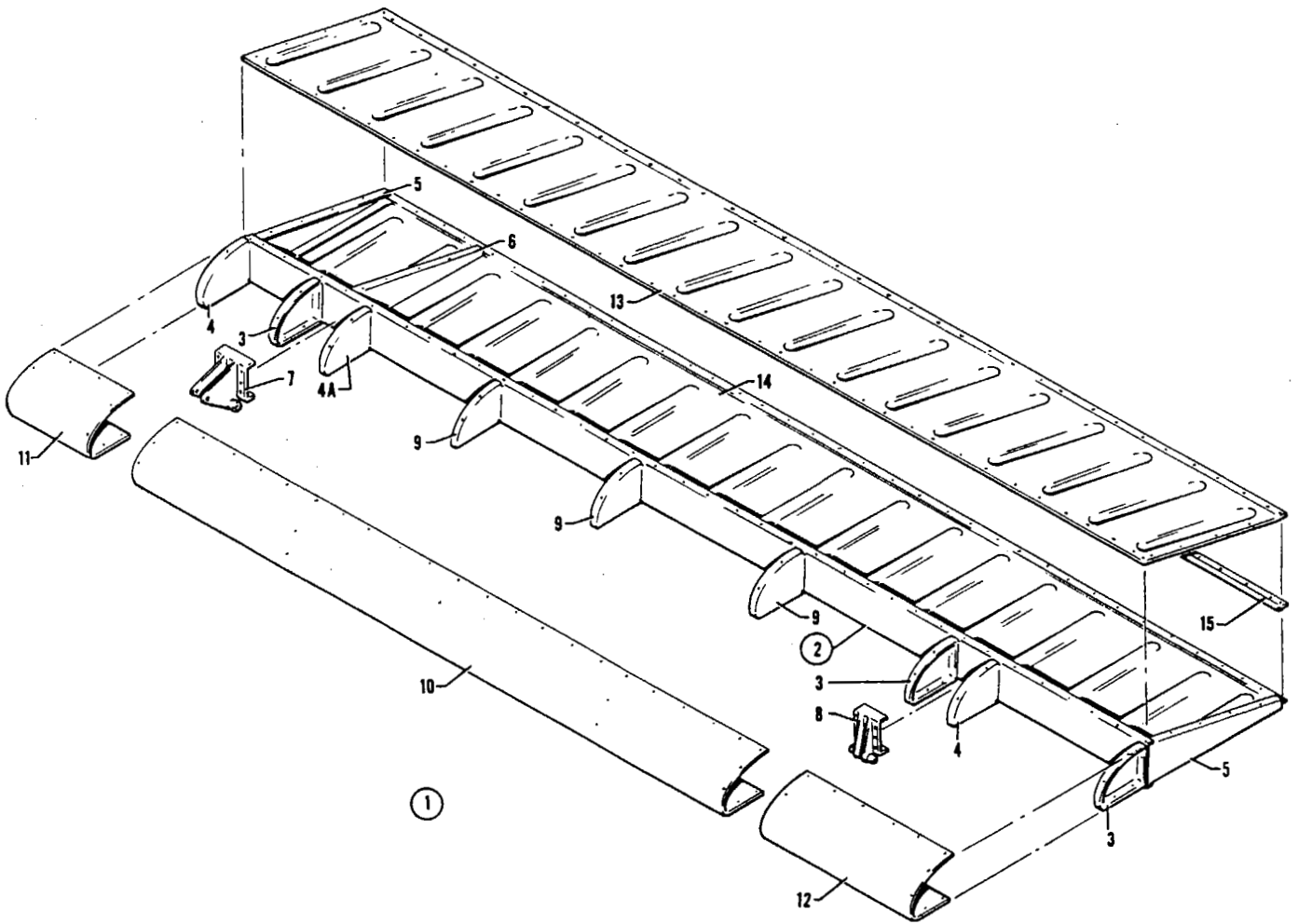

Figure 6 Flap Assembly

---

# PIPER PARTS CATALOG

CODE EXPLANATIONS FOR FIGURE 6

PIPER PARTS CATALOG

Figure and Index Number	Part Number	Code	NOMENCLATURE	No. Req.	SERIAL NUMBERS AFFECTED
6-1	60709-02		FLAP ASSEMBLY - Left	1	
	60709-03		FLAP ASSEMBLY - Right	1	
-2	60709-14		SPAR ASSEMBLY - Flap, left (complete)	1	
	60709-15		SPAR ASSEMBLY - Flap, right (complete)	1	
-3	40451-02		BULKHEAD - Flap, left	3	
	40451-03		BULKHEAD - Flap, right	3	
-4	40451-03		BULKHEAD - Flap, left	2	
	40451-02		BULKHEAD - Flap, right	2	
-4a	40451-07		BULKHEAD - Flap, left	1	
	40451-06		BULKHEAD - Flap, right	1	
-5	60708-02		RIB - Flap	2	
-6	60708-06		RIB - Flap	1	
-7	11682-00		HINGE ASSEMBLY - Flap, inboard	1	
-8	41881-02		HINGE ASSEMBLY - Flap, outboard	1	
-9	40451-03		BULKHEAD - Flap, left	3	
	40451-02		BULKHEAD - Flap, right	1	
-10	60709-06		SKIN - Flap, leading edge	1	
-11	60401-04		SKIN - Flap, leading edge, inboard, left	1	
	60401-05		SKIN - Flap, leading edge, inboard, right	1	
-12	60709-08		SKIN - Flap, leading edge, outboard, left	1	
	60709-09		SKIN - Flap, leading edge, outboard, right	1	
-13	60709-10		SKIN - Flap, trailing edge, top, left	1	
	60709-11		SKIN - Flap, trailing edge, top, right	1	
-14	60709-12		SKIN - Flap, trailing edge, bottom, left	1	
	60709-13		SKIN - Flap, trailing edge, bottom right	1	
-15	60709-18		REINFORCEMENT - Trailing edge	1	

When ordering, always specify Part Number, Description, and Serial Number of Aircraft





---

# PIPER PARTS CATALOG

---

CODE EXPLANATIONS FOR FIGURE 7

PIPER PARTS CATALOG

Figure and Index Number	Part Number	Code	NOMENCLATURE	No. Req.	SERIAL NUMBERS AFFECTED
7-1	60714-02		AILERON ASSEMBLY - Left	1	
	60714-03		AILERON ASSEMBLY - Right	1	
-2	60714-16		*SPAR ASSEMBLY - Left (complete)	1	
	60714-17		*SPAR ASSEMBLY - Right (complete)	1	
-3	40451-02		**BULKHEAD - Flap, left	4	
	40451-03		**BULKHEAD - Flap, right	4	
-4	40451-03		**BULKHEAD - Flap, left	4	
	40451-02		**BULKHEAD - Flap, right	4	
-5	60708-02		**RIB - Aileron	1	
-6	60708-03		**RIB - Aileron	1	
-7	60708-04		**RIB - Aileron	1	
-8	60708-05		**RIB - Aileron	2	
-9	41881-00		**HINGE ASSEMBLY - Aileron	2	
-10	41891-00		**HINGE ASSEMBLY - Aileron, center	1	
-11	40501-00		**HORN ASSEMBLY - Aileron	1	
-12	40451-03		*BULKHEAD - Aileron, left	6	
	40451-02		*BULKHEAD - Aileron, right	6	
-13	60714-04		*SKIN - Aileron, inboard, left	1	
	60714-05		*SKIN - Aileron, inboard, right	1	
-14	60714-06		*SKIN - Aileron, center, inboard, left	1	
	60714-07		*SKIN - Aileron, center, inboard, right	1	
-15	60714-08		*SKIN - Aileron, center, outboard, left	1	
	60714-09		*SKIN - Aileron, center, outboard, right	1	
-16	60714-10		*SKIN - Aileron, outboard, left	1	
	60714-11		*SKIN - Aileron, outboard, right	1	
-17	60714-12		*SKIN - Aileron, trailing edge, inboard, top, left	1	
	60714-13		*SKIN - Aileron, trailing edge, inboard, top, right	1	
-18	60714-14		*SKIN - Aileron, trailing edge, inboard, bottom, left	1	
	60714-15		*SKIN - Aileron, trailing edge, inboard, bottom, right	1	
-19	60714-30		*SKIN - Aileron, trailing edge, outboard, top, left	1	
	60714-29		*SKIN - Aileron, trailing edge, outboard, top, right	1	
-20	60714-28		*SKIN - Aileron, trailing edge, outboard, bottom, left	1	
	60714-27		*SKIN - Aileron, trailing edge, outboard, bottom, right	1	
-21	60748-03		*WEIGHT - Aileron balance	1	
-22	18379-00		*TAB - Aileron trim	1	
-23	60714-26		*REINFORCEMENT - Trailing edge	1	

When ordering, always specify Part Number, Description, and Serial Number of Aircraft

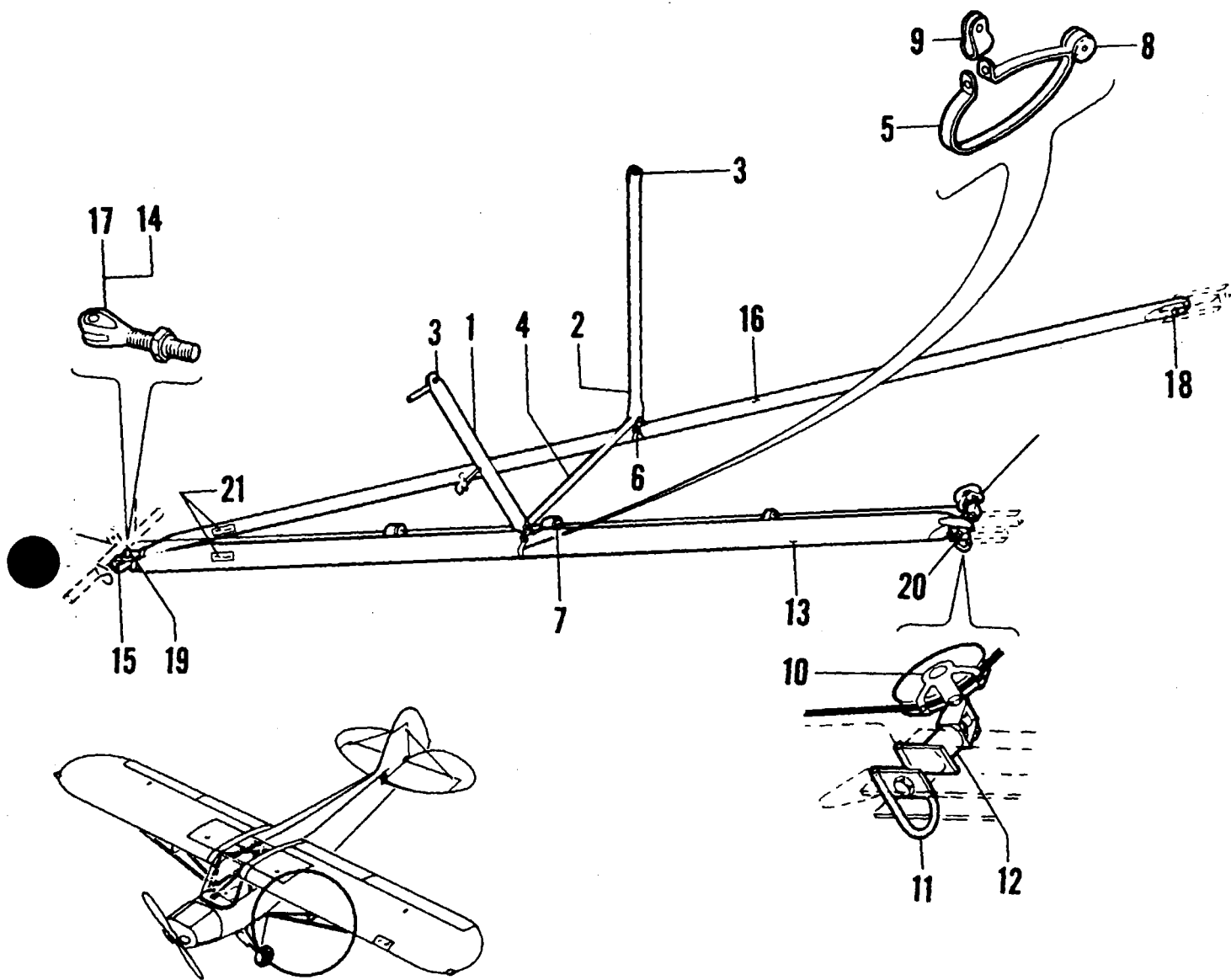

Figure 8 Strut Installation

---

# PIPER PARTS CATALOG

CODE EXPLANATIONS FOR FIGURE 8

## PIPER PARTS CATALOG

Figure and Index Number	Part Number	Code	NOMENCLATURE	No. Req.	SERIAL NUMBERS AFFECTED
8-	10578		DRAWING - Strut Installation, Lift and Jury		
8-1	12571-02		STRUT - Jury, front	2	
-2	12571-03		STRUT - Jury, rear	1	
-3	400 438		BOLT - (AN3-4A)	4	
	407 564		WASHER - (AN960-10)	4	
	406 681		NUT - (Elastic Stop Nut No 22M02)	4	
-4	12591-02		TUBE - Jury strut spacer	2	
-5	10654-02		CLAMP ASSEMBLY - Front jury strut	2	
-6	10656-00		CLAMP - Rear jury strut	2	
-7	40081-00		RING - Snap, cable fairlead	4	
-8	40701-00		FAIRLEAD - Cable, segment	8	
-9	80002-41		CLAMP - Jury strut	4	
-10	10552-00		HOUSING ASSEMBLY - Pulley, LH	1	
	10552-01		HOUSING ASSEMBLY - Pulley, RH	1	
-11	12345-04		BRACKET ASSEMBLY - Tie down	2	
-12	15631-02		BUSHING - Spacer	2	
-13	89202-02		STRUT ASSEMBLY - Lift front	2	
-14	89201-02		*FORK ASSEMBLY	1	
-15	13241-00		BOLT - Lift strut attachment	2	
	404 395		NUT - (AN320-6)	2	
	424 059		PIN - Cotter (AN320-6)	2	
-16	89203-02		STRUT ASSEMBLY - Rear lift	2	
-17	89201-02		*FORK ASSEMBLY	1	
-18	401 355		BOLT - (AN5-14A)	2	
	407 566		WASHER - (AN960-516)	2	
	406 683		NUT - (42E054)	2	
-19	13241-00		BOLT - Lift strut attachment	2	
	404 395		NUT - (AN320-6)	2	
	424 059		PIN - Cotter (AN380-3-3)	2	
-20	401 366		BOLT - (AN5-27A)	2	
	406 683		NUT - (Elastic Stop Nut No 42E054)	2	
-21	80944-02		DECAL - No Step	4	

When ordering, always specify Part Number, Description, and Serial Number of Aircraft

# PIPER PARTS CATALOG

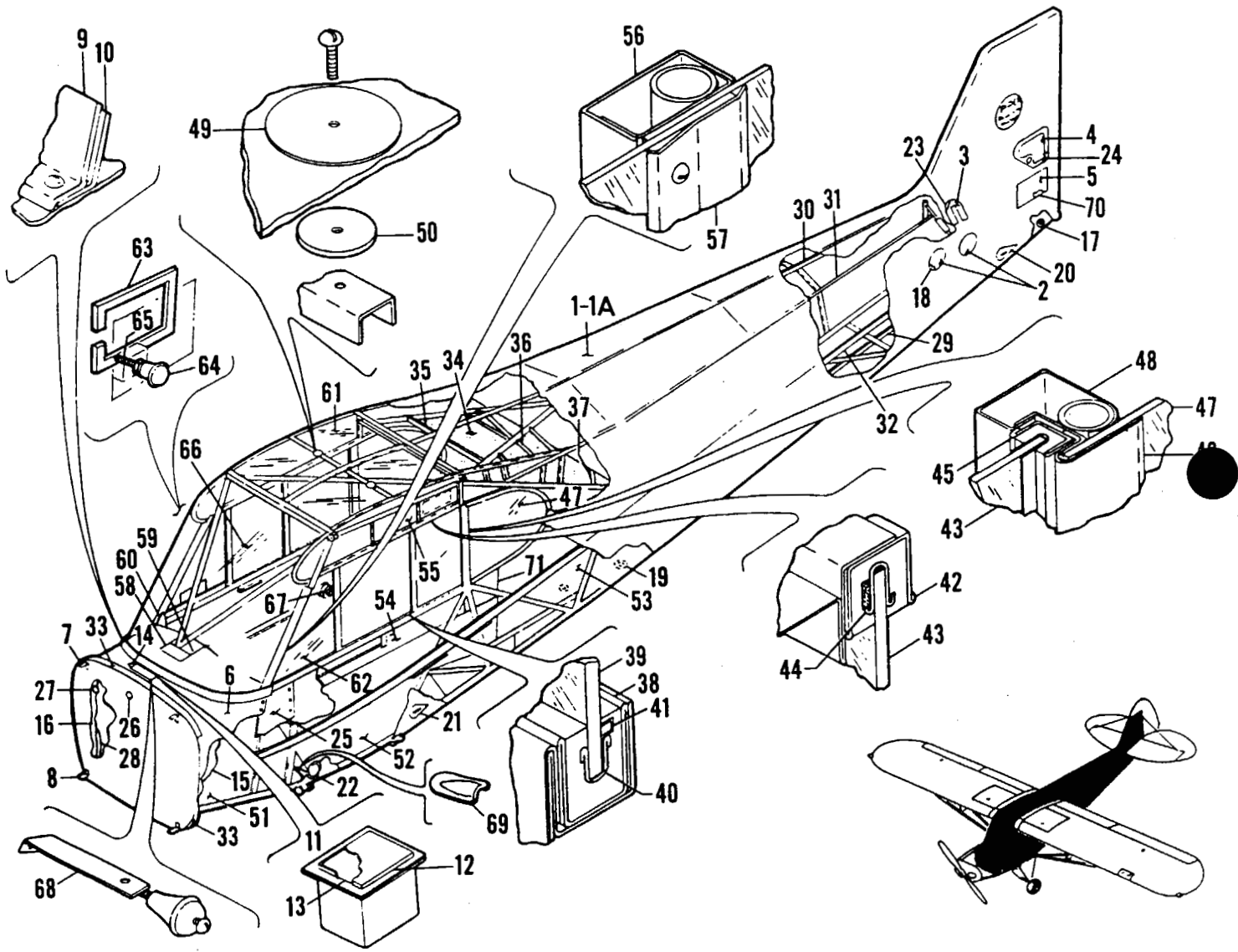

Figure 9 Covered Fuselage Assembly, Left View

---

# PIPER PARTS CATALOG

---

CODE EXPLANATIONS FOR FIGURE 9

PIPER PARTS CATALOG

Figure and Index Number	Part Number	Code	NOMENCLATURE	No. Req.	SERIAL NUMBERS AFFECTED
9-	14486 14836		DRAWING - Fuselage Assembly, Complete DRAWING - Fabric or Ceconite Installation, Fuselage		
-1	754 825		FUSELAGE ASSEMBLY - Ceconite covered (with seat and floor)	1	
-1a	459 134		*ENVELOPE - Fuselage, Ceconite (BLU PA-18-F)	1	
-2	12761-02		COVER - Inspection	4	
	12761-02		COVER - Inspection (battery drain access)	1	
-3	60571-00		COVER - Stabilizer yoke inspection, LH	1	
	60571-01		COVER - Stabilizer yoke inspection, RH	1	
-4	64835-00		PANEL - Tail inspection, LH	1	
	64835-01		PANEL - Tail inspection, RH	1	
-5	82461-00		COVER - Inspection, rectangular	1	
-6	14849-02		COWL ASSEMBLY - Fuselage	1	
-7	12379-02		*ANGLE - Cowl attachment	2	
-8	12379-00		*ANGLE - Cowl attachment	2	
-9	12377-00		*STRIP - Windshield, front	1	
-10	12378-00		*STRIP - Windshield, rear	1	
-11	14059-00		*BOX ASSEMBLY - Cold air vent	1	
-12	14060-00		**VALVE	1	
-13	14075-00		**SEAL	1	
-14	14061-00		*GASKET - Seal	1	
-15	10933-00		BLANKET - Cowl insulator, LH	1	
	10933-01		BLANKET - Cowl insulator, RH	1	
-16	10934-00		BLANKET - Cowl insulator, front	1	
-17	80122-53		GROMMET - Drain	1	
-18	80122-49		GROMMET	1	
	80122-49		GROMMET - Access	1	
-19	80122-51		GROMMET - Battery drain vent inlet with sealed battery box installation	1	
-20	60863-03		GROMMET	2	
-21	60863-05		GROMMET	2	
-22	10984-00		GROMMET	2	
-23	10292-00		GROMMET	2	
-24	64834-00		GROMMET	2	
-25	12818-00		PANEL - Side, LH	1	
	12818-01		PANEL - Side, RH	1	
-26	80122-07		WASHER - Cowl attachment	3	
-27	80122-43		WASHER - Fibre	4	
-28	24032-22		COVER - Firewall, blanket, black	1	
-29	14978-00		STRINGER - Bottom	1	
-30	14983-03		STRINGER - Top	1	
-31	14984-02		STRINGER - Top, LH and RH	2	
-32	14979-00		STRINGER - LH	1	
	14979-00		STRINGER - RH	1	
-33	180 810		WEBBING - Cowl (83891)	4	
-34	12448-07		HEADLINING ASSEMBLY - Cockpit	1	
-35	12193-10		CHANNEL - No 1, headlining arch	1	
-36	12193-08		CHANNEL - No 2, headlining arch	1	
-37	12193-09		CHANNEL - No 3, headlining arch	1	
-38	11432-11		CHANNEL - Weatherstrip	1	
-39	12254-00		WINDOW ASSEMBLY - Sliding, front	1	
-40	11648-02		*CHANNEL - Weatherstrip	2	
-41	12254-03		*STIFFENER - Front window	1	
-42	11432-10		CHANNEL - Weatherstrip	1	
-43	12255-00		WINDOW ASSEMBLY - Sliding rear	1	

When ordering, always specify Part Number, Description, and Serial Number of Aircraft



## PIPER PARTS CATALOG

Figure and Index Number	Part Number	Code	NOMENCLATURE	No. Req.	SERIAL NUMBERS AFFECTED
9-44	11648-02		*CHANNEL - Weatherstrip	2	
-45	11432-09		CHANNEL - Weatherstrip, front and rear	2	
-46	12259-00		TRIM STRIP - Sliding window, exterior	1	
-47	10545-00		WINDOW - Rear enclosure	2	
-48	13091-00		TRIM STRIP - Sliding window, interior	1	
-49	81342-45		WASHER	2	
-50	85012-14		WASHER	2	
-51	10776-02		PANEL - Cockpit, front, LH	1	
-52	12308-05		PANEL - Cockpit, center, LH	1	
-53	12444-00		PANEL - Cockpit, rear, LH	1	
-54	12309-00		PANEL ASSEMBLY - Throttle control	1	
-55	15271-08		PANEL - Upper trim, LH	1	
-56	12261-00		TRIM STRIP - Windshield, interior, LH	1	
	12260-00		TRIM STRIP - Windshield, interior, RH	1	
-57	12264-00		TRIM STRIP - Windshield, exterior, LH	1	
	12264-01		TRIM STRIP - Windshield, exterior, RH	1	
-58	13373-02		PLATE - Trim	1	
-59	13373-04		PLATE - Trim	1	
-60	11994-22		GUSSET - Front enclosure, inside	1	
-61	13433-02		WINDOW ASSEMBLY - Top deck, tinted	1	
-62	14275-00		WINDOW ASSEMBLY - Front, left	1	
-63	13914-00		*GASKET - Ventilator	1	
-64	471 077		*KNOB - Ventilator	1	
-65	13903-00		*SCREW - Ventilator assembly	1	
-66	12430-00		WINDSHIELD	1	
-67	99479-02		GAUGE - Air temperature	1	
-68	13483-00		ARM ASSEMBLY - Air vent control	1	
-69	14435-00		COVER - Brake line	2	
-70	80541-02		GROMMET	4	
-71	12314-00		PANEL ASSEMBLY - Rear of Throttle Panel	1	

When ordering, always specify Part Number, Description, and Serial Number of Aircraft

PIPER PARTS CATALOG

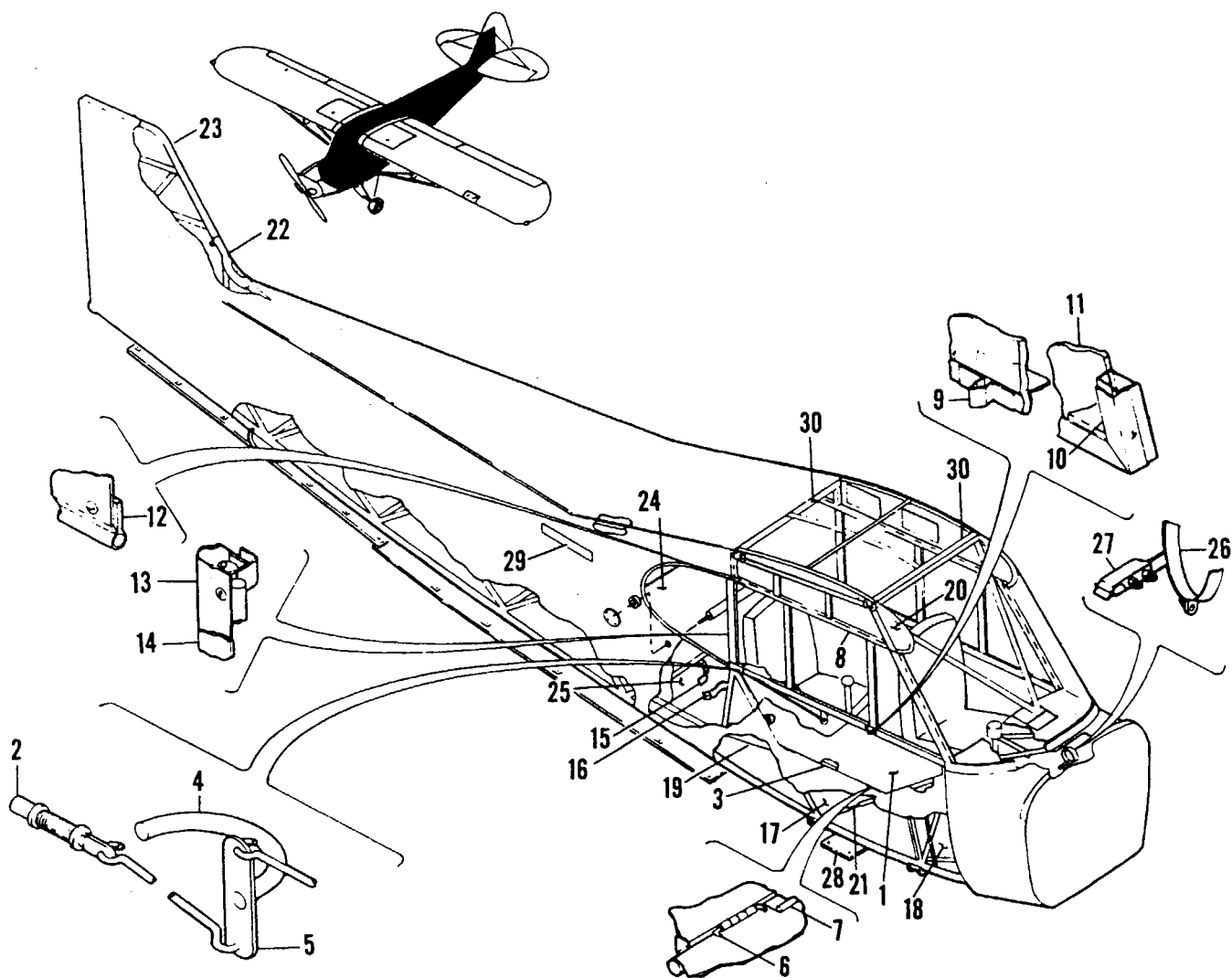

Figure 10 Covered Fuselage Assembly, Right View

---

# PIPER PARTS CATALOG

---

CODE EXPLANATIONS FOR FIGURE 10

PIPER PARTS CATALOG

Figure and Index Number	Part Number	Code	NOMENCLATURE	No. Req.	SERIAL NUMBERS AFFECTED
10-1	50183-11		DOOR ASSEMBLY - Fuselage, Ceconite covered	1	
-2	50131-00		*PLUNGER ASSEMBLY - Complete	2	
-3	12257-12		*FRAME ASSEMBLY	1	
-4	14216-00		**HANDLE ASSEMBLY - Aluminum (for all replacement doors)	1	
-5	50192-00		**LINK ASSEMBLY	1	
-6	86092-15		PIN - Hinge	2	
-7	52841-22		WEATHERSTRIP ASSEMBLY - Enclosure door (red)	1	
	52841-24		WEATHERSTRIP ASSEMBLY - Enclosure door (black and white)	1	
	52841-26		WEATHERSTRIP ASSEMBLY - Enclosure door (black)	2	
-8	12256-10		DOOR ASSEMBLY - Upper	1	
-9	83481-00		*STUD - Door catch	1	
-10	10049-02		*TRIM STRIP - Front	1	
-11	12279-00		*WINDOW	1	
-12	187 610		MOULDING - Upper and lower enclosure doors (Die No 1923 Cont Rubber Works)	9'	
-13	13093-00		STRIP - Moulding attachment	1	
-14	10668-00		TRIM STRIP - Window, rear	1	
-15	12036-03		STRAP ASSEMBLY - Baggage, tip end	1	
-16	12036-02		STRAP ASSEMBLY - Baggage, buckle end	1	
-17	10930-00		PANEL - Cockpit, center, RH	1	
-18	12311-00		PANEL - Cockpit, front, RH	1	
-19	12445-00		PANEL - Cockpit, rear, RH	1	
-20	14337-05		PANEL - Cockpit, upper right	1	
-21	180 497		FELT - Chafing, SAE F-50, 0.065 x 1/2"	19'	
-22	60602-00		FAIRING - Fin leading edge	1	
-23	40592-00		FIN ASSEMBLY - Uncovered	1	
-24	13471-03		PANEL - Baggage compartment, rear	1	
-25	12284-02		PANEL - Baggage compartment, bottom	1	
-26	12855-00		LOCK - Control stick (used when no radio is installed)	1	
-27	52745-00		CATCH - Control lock	1	
-28	82461-00		COVER - Inspection, rectangular	1	
-29	60753-02		DECAL - "Piper Super Cub"	2	
-30	12265-00		TRIM STRIP - Window installation, top deck	1	

When ordering, always specify Part Number, Description, and Serial Number of Aircraft

PIPER PARTS CATALOG

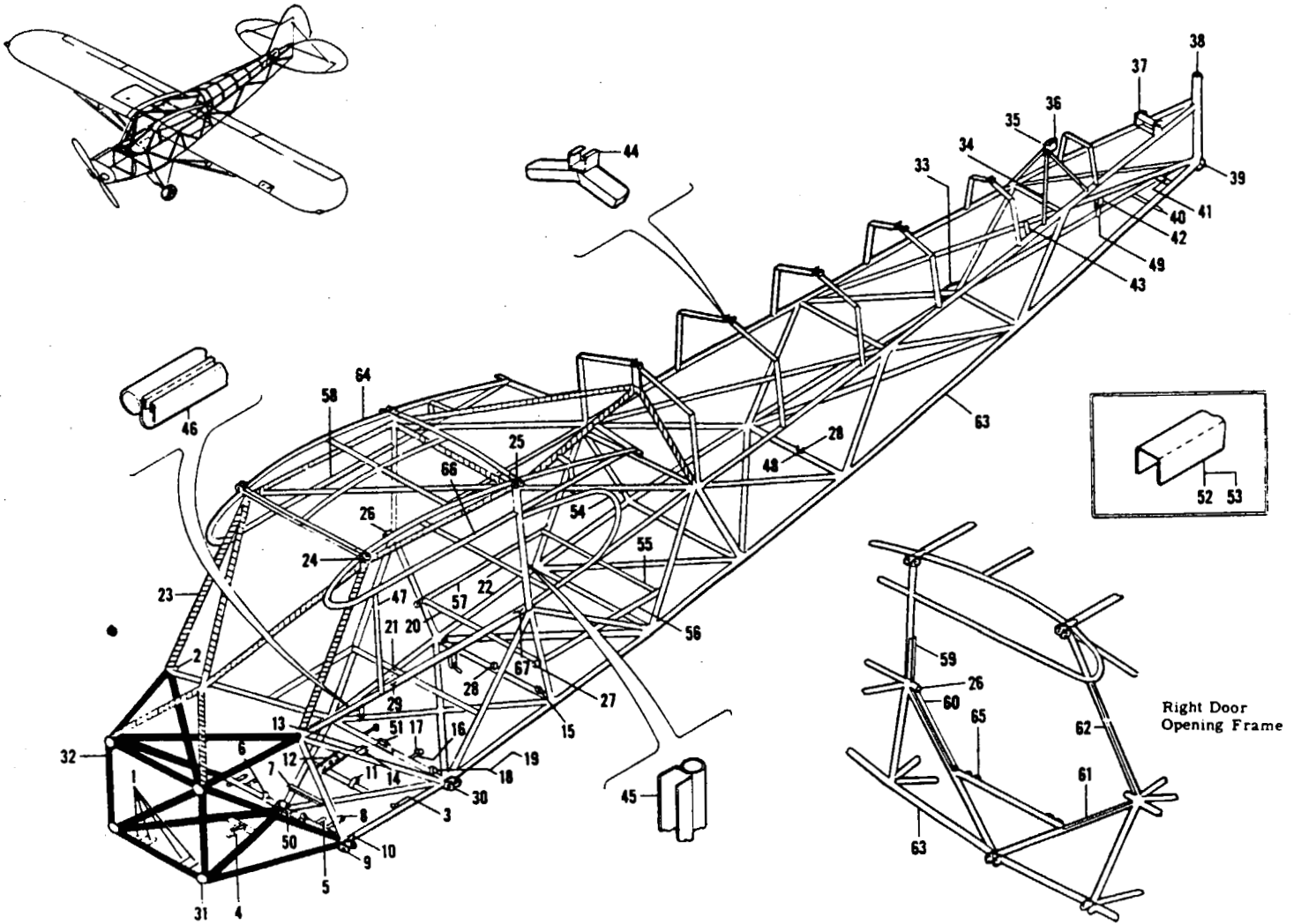

Figure 11 Fuselage Frame Assembly

---

# PIPER PARTS CATALOG

CODE EXPLANATIONS FOR FIGURE 11

## PIPER PARTS CATALOG

Figure and Index Number	Part Number	Code	NOMENCLATURE	No. Req.	SERIAL NUMBERS AFFECTED
11-	12446 12183		DRAWING - Fuselage Frame and Super Structure DRAWING - Frame Assembly, Fuselage		
-1	24121-02		FITTING - Rudder pedal attachment, front	4	
-2	21752-03		STOP ASSEMBLY - Fuselage door, front	1	
-3	24101-00		FITTING - Floorboard attachment	6	
-4	12179-00		BRACKET - Elevator cable pulley	2	
-5	24121-03		FITTING - Rudder pedal attachment, rear	4	
-6	10466-09		FITTING - Clamp, front seat installation, front	2	
-7	10134-00		CHANNEL - Brake unit support	1	
-8	12777-00		FITTING ASSEMBLY - Flap lever	1	
-9	21272-03		FITTING ASSEMBLY - Landing gear, front	2	
-10	81272-15		GUSSET - Front landing gear fitting	2	
-11	81332-09		FITTING - Clamp, front seat installation, rear	2	
-12	14308-00		PLATE - Fuel shut off valve, mounting	1	
-13	21571-01		BRACKET - Stabilizer adjustment crank, right	1	
-14	21571-00		BRACKET - Stabilizer adjustment crank, left	1	
-15	11692-02		BRACKET - Rudder cable pulley	1	
-16	20841-00		STOP - Torque tube horn, left	1	
	20841-01		STOP - Torque tube horn, right	1	
-17	85061-00		CAPSCREW - Stop	2	
-18	20951-00		PLATE - Fuselage aileron pulley housing, left rear	1	
	20951-01		PLATE - Fuselage aileron pulley housing, right rear	1	
-19	20961-00		PLATE - Fuselage aileron pulley housing, front left	1	
	20961-01		PLATE - Fuselage aileron pulley housing, front right	1	
-20	12178-03		TUBE - Rear seat bottom, rear	1	
-21	12178-02		TUBE - Rear seat bottom, front	1	
-22	10818-00		TUBE - Square, rear seat back	1	
-23	752 978		TOP DECK SECTION ASSEMBLY - Fuselage frame	1	
-24	12767-00		* FITTING - Wing hinge, front left	1	
	12767-01		* FITTING - Wing hinge, front right	1	
-25	11821-00		* FITTING - Wing hinge, rear left	1	
	11821-01		* FITTING - Wing hinge, rear right	1	
-26	21752-02		STOP ASSEMBLY - Fuselage door, rear	1	
-27	11829-03		FITTING - Rear safety belt attachment	2	
-28	11692-00		BRACKET - Elevator cable pulley	2	
-29	10565-00		BRACKET ASSEMBLY - Throttle (with tube)	1	
-30	12184-02		FITTING - Landing gear and lift strut, left rear	1	
	12184-03		FITTING - Landing gear and lift strut, right rear	1	
-31	82341-02		BUSHING - Engine mount bulkhead	4	
-32	751 376		BULKHEAD SECTION ASSEMBLY - Fuselage frame	1	
-33	20652-00		HANDLE - Fuselage fitting	1	
-34	80022-20		BEARING - Stabilizer screw, lower	1	
-35	20491-03		BEARING - Stabilizer screw, upper	1	
-36	20491-02		BRACKET - Fin, front post attachment	1	
-37	21161-00		SUPPORT ASSEMBLY - Stabilizer	1	
-38	22412-00		TAIL POST ASSEMBLY	1	
-39	20611-02		FITTING - Tail wheel spring attachment	1	
-40	80292-15		FITTING - Tail tie rod attachment	2	
-41	20631-00		FITTING - "U", tail wheel spring attachment	1	
-42	11692-02		BRACKET - Lower bungee cable pulley attachment	1	
-43	20551-00		BRACKET - Stabilizer adjustment idler	1	
-44	20391-00		CLIP - Stringer attachment	25	
-45	12205-06		CHANNEL - Window	1	
-46	10061-00		CHANNEL - Window, front, bottom, LH	1	
-47	12206-00		CHANNEL - Window	1	
-48	12180-00		BRACKET - Elevator cable pulley, lower	1	

When ordering, always specify Part Number, Description, and Serial Number of Aircraft

## PIPER PARTS CATALOG

Figure and Index Number	Part Number	Code	NOMENCLATURE	No. Req.	SERIAL NUMBERS AFFECTED
11-49	11207-03		GUARD - Bungee cable pulley	1	
-50	20981-02		BRACKET ASSEMBLY - Torque tube, front bearing	1	
-51	20751-00		BRACKET ASSEMBLY - Torque tube, rear bearing	1	
-52	750 283		CHANNEL - "U" steel 3/8" x 0 020 (6' pieces)	1	
-53	750 284		CHANNEL - "U" steel 1/4" x 0 016 (6' pieces)	1	
-54	10058-00		CHANNEL - Rear window	2	
-55	11408-12		ANGLE - Baggage compartment support, rear	1	
-56	11408-14		ANGLE - Baggage compartment support, LH	1	
-57	11408-13		ANGLE - Baggage compartment support, RH	1	
-58	12205-02		CHANNEL - Upper enclosure door, top	1	
-59	12205-05		CHANNEL - Upper enclosure, rear	1	
-60	12205-04		CHANNEL - Lower enclosure door, rear	1	
-61	12205-03		CHANNEL - Lower enclosure door, front	1	
-62	12202-00		CHANNEL - Windshield, LH	1	
	12200-00		CHANNEL - Windshield, RH	1	
-63	12446-08		FUSELAGE FRAME AND SUPER STRUCTURE ASSEMBLY	1	
-64	752 979		TOP DECK SECTION ASSEMBLY - Fuselage super structure	1	
-65	10300-02		HINGE - Lower enclosure door	2	
-66	12203-00		CHANNEL - Sliding window, top	1	
-67	11546-02		CHANNEL - Sliding window, bottom	1	

When ordering, always specify Part Number, Description, and Serial Number of Aircraft



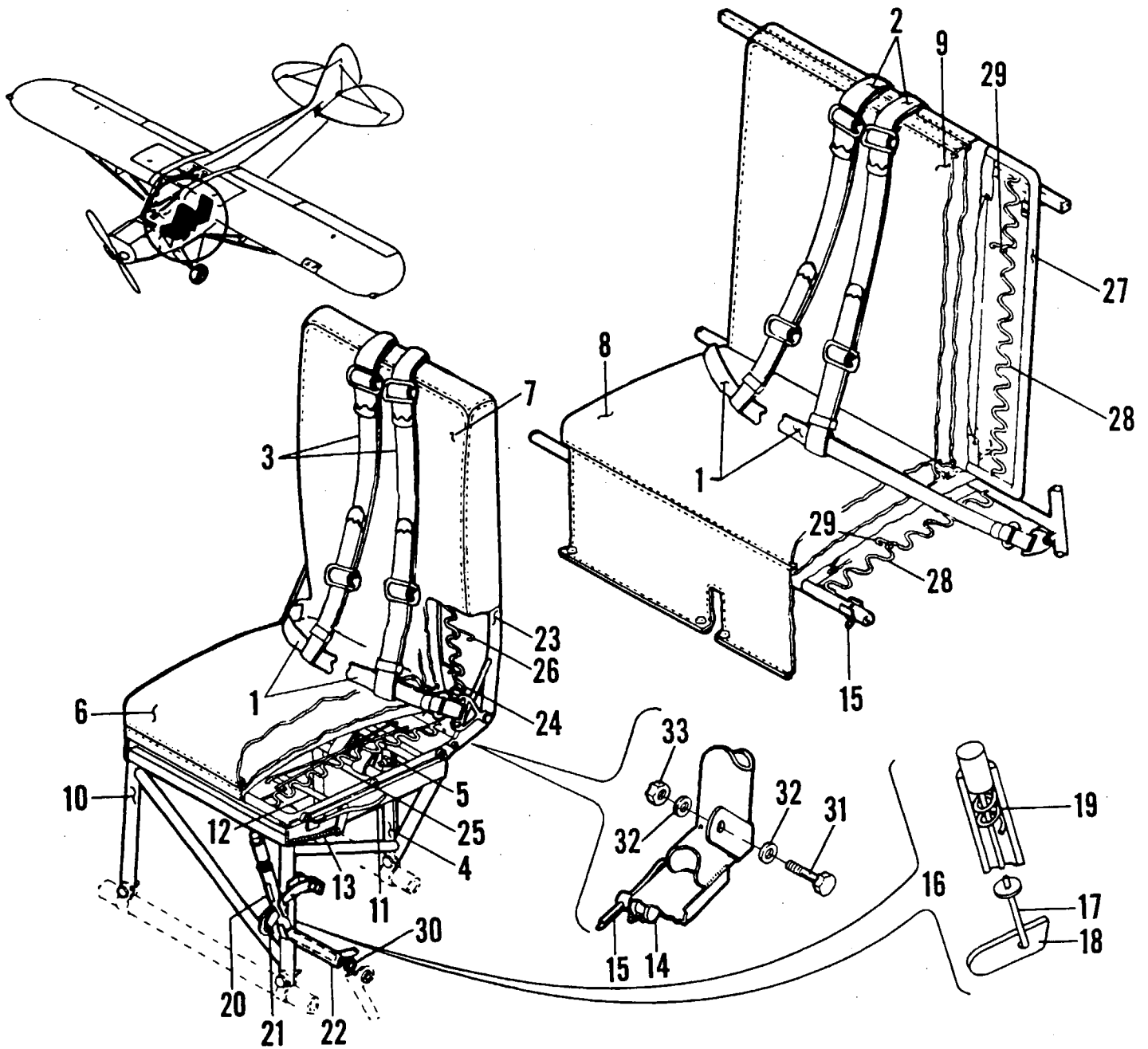

Figure 12 Seats Installation

---

# PIPER PARTS CATALOG

CODE EXPLANATIONS FOR FIGURE 12

PIPER PARTS CATALOG

Figure and Index Number	Part Number	Code	NOMENCLATURE	No. Req.	SERIAL NUMBERS AFFECTED
12-	14950		DRAWING - Shoulder Harness and Seats Installation		
-1	25801-05		BELT ASSEMBLY - Safety, front and rear, black	2	
-2	13129-05		STRAP ASSEMBLY - Rear, black	2	
-3	13129-04		STRAP ASSEMBLY - Front, black	2	
-4	13300-00		BRACKET ASSEMBLY - Front strap installation	1	
-5	13305-00		CLAMP - Front strap installation	2	
-6	12294-28		CUSHION ASSEMBLY - Front seat, bottom, black	1	
-7	12293-48		CUSHION ASSEMBLY - Front seat, back, black	1	
-8	10763-46		CUSHION ASSEMBLY - Rear seat, bottom, black	1	
-9	12289-39		CUSHION ASSEMBLY - Rear seat, back, black	1	
-10	12268-18		SEAT BASE ASSEMBLY - Front	1	
-11	12079-00		* HANDLE ASSEMBLY - Seat release	1	
-12	12269-00		* ROD - Extension	1	
-13	83302-13		* SPRING - Return (487283)	1	
-14	12914-00		PIN - Stop	1	
-15	454 888		CLIP - Fastener, #62	3	
-16	12774-02		LEVER ASSEMBLY - Flap control	1	
-17	11699-06		*PLUNGER ASSEMBLY - Flap control	1	
-18	11700-00		**PAWL	1	
-19	50111-00		**SPRING	1	
-20	11723-00		DECAL - Flap lever	1	
-21	12776-00		RATCHET - Flap lever	1	
-22	80132-10		TUBE - Liner	1	
-23	12267-16		SEAT FRAME ASSEMBLY - Front	1	
-24	487 274		*SPRING	4	
-25	487 272		*SPRING	4	
-26	11420-03		*LINK - Spring connector	9	
-27	12244-00		SEAT FRAME ASSEMBLY - Rear back	1	
-28	487 274		*SPRING	8	
-29	11420-03		*LINK - Spring connector	14	
-30	14340-00		WASHER - Shim, flap handle installation	AR	
-31	401 450		BOLT - AN6-7a	4	
-32	407 567		WASHER - AN960-616	8	
-33	404 856		NUT - MS20365-624C	4	

When ordering, always specify Part Number, Description, and Serial Number of Aircraft

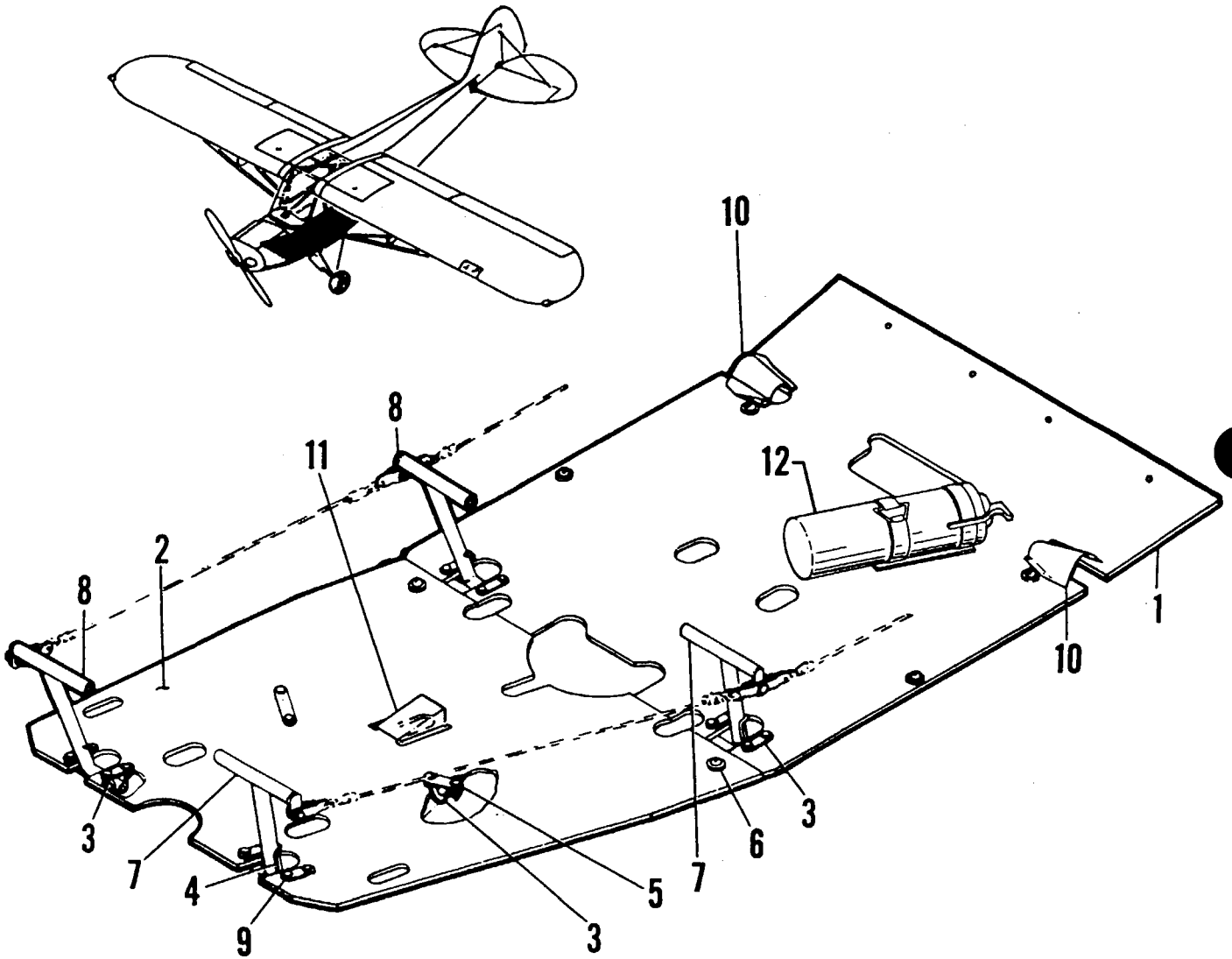

Figure 13 Rudder Pedals and Floorboards Installation

---

# PIPER PARTS CATALOG

---

CODE EXPLANATIONS FOR FIGURE 13

PIPER PARTS CATALOG

Figure and Index Number	Part Number	Code	NOMENCLATURE	No. Req.	SERIAL NUMBERS AFFECTED
13-	10769 10735		DRAWING - Rudder Pedal Installation DRAWING - Floorboards Installation		
-1	10799-00		FLOORBOARD ASSEMBLY - Rear	1	
-2	13743-00		FLOORBOARD - Front	1	
-3	80222-03		CLAMP	10	
-4	40941-00		SPRING - Rudder pedal	4	
-5	81262-08		LINK	10	
-6	80122-10		WASHER	6	
-7	40842-04		PEDAL ASSEMBLY - Rudder, LH	2	
-8	40842-05		PEDAL ASSEMBLY - Rudder, RH	2	
-9	85012-04		WASHER	AR	
	85012-05		WASHER	AR	
	85012-06		WASHER	AR	
-10	50042-00		COVER - Pulley housing	2	
-11	12810-00		COVER - Pulley	1	
-12	459 848		EXTINGUISHER - Fire (SCT42211-00)	1	

When ordering, always specify Part Number, Description, and Serial Number of Aircraft

PIPER PARTS CATALOG

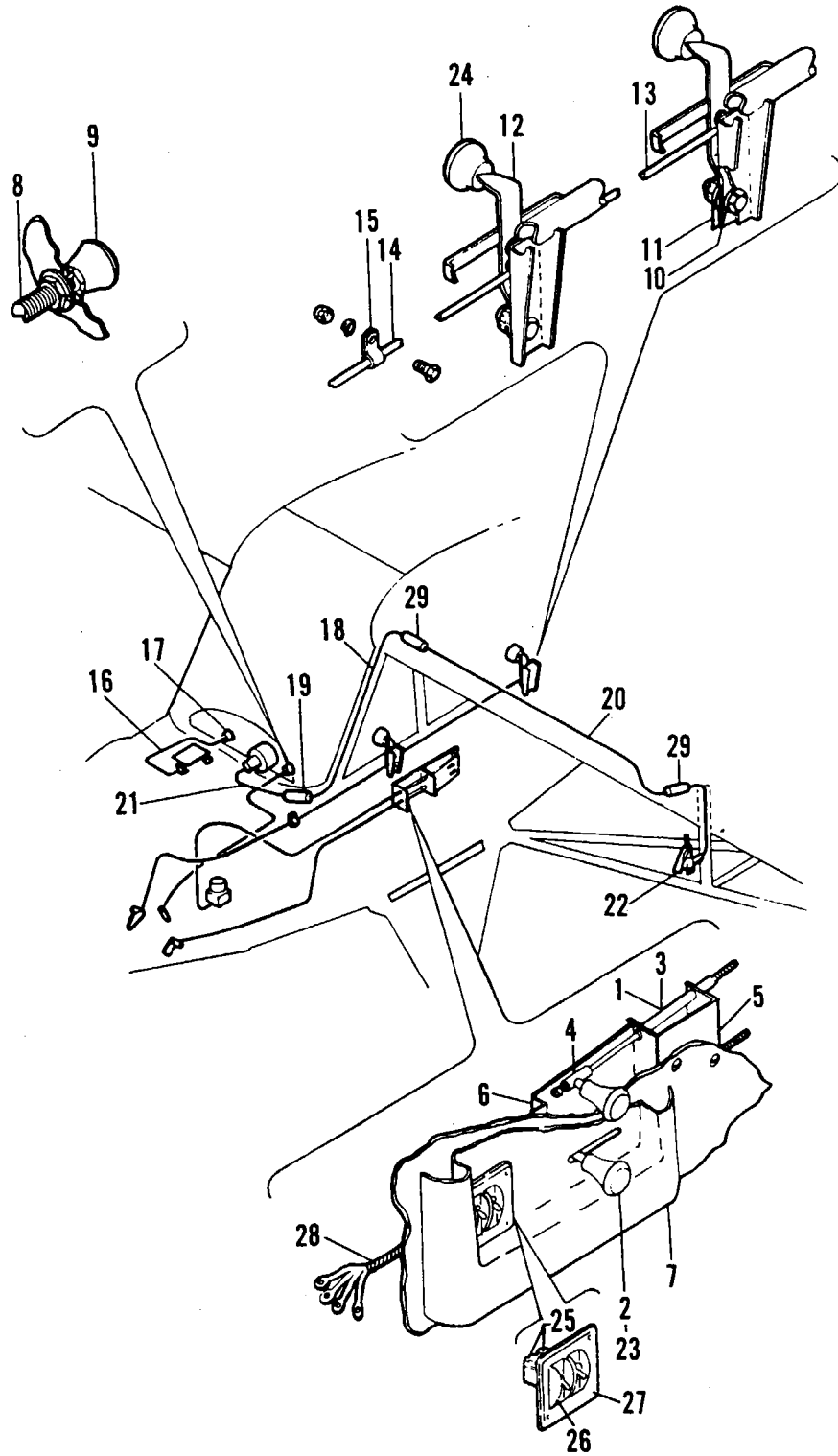

Figure 14 Throttle, Cabin and Carburetor Heat Mixture Controls

---

# PIPER PARTS CATALOG

CODE EXPLANATIONS FOR FIGURE 14



PIPER PARTS CATALOG

Figure and Index Number	Part Number	Code	NOMENCLATURE	No. Req.	SERIAL NUMBERS AFFECTED
14-1	12955-00		CABLE ASSEMBLY - Cabin and carburetor heat control	2	
-2	471 060		*KNOB	1	
-3	16775-00		*CABLE ASSEMBLY - Cabin and carburetor heat control (less knob)	1	
-4	14056-00		BUSHING - Attachment, cabin and carburetor heat control cable	2	
-5	10780-00		BRACKET ASSEMBLY - Front	1	
-6	14055-00		BRACKET - Rear	1	
-7	10666-06		PANEL ASSEMBLY - Ignition switch, carburetor and cabin heat	1	
-8	16775-00		CABLE ASSEMBLY - Mixture control (less knob)	1	
-9	471 053		KNOB - Mixture control (3004-S-M) pastel red	1	
-10	81342-20		WASHER - Throttle, vellumoid friction	4	
-11	81172-20		LUG - Friction (steel at throttle assembly)	2	
-12	41491-00		LEVER - Throttle control	2	
-13	41551-00		LINK - Throttle lever connector	1	
-14	12694-03		CABLE ASSEMBLY - Throttle control (Lycoming engine)	1	
-15	80032-51		CLAMP - Throttle control	1	
-16	16775-00		CABLE ASSEMBLY - Cold air vent control (less knob)	1	
-17	471 060		KNOB - Cold air vent, black	1	
-18	61323-10		TUBING - Airspeed	2	
-19	83161-02		HOSE - Airspeed, rubber	1	
-20	13541-16		TUBING - Airspeed, left wing	2	
-21	13541-04		TUBE - Airspeed indicator	1	
-22	13764-00		TUBE ASSEMBLY - Airspeed (pitot and static)	1	
-23	471 060		KNOB - Cabin and carburetor heat control	2	
-24	18875-07		KNOB - Throttle lever, black	2	
-25	487 823		SWITCH - Ignition (#110-S-67)	2	
-26	15300-00		GUARD - Switch	2	
-27	15299-00		PANEL - Magneto switches	1	
-28	89216-02		HARNESS ASSEMBLY - Shielded magneto	1	
-29	83161-02		HOSE - Airspeed, rubber	2	

When ordering, always specify Part Number, Description, and Serial Number of Aircraft

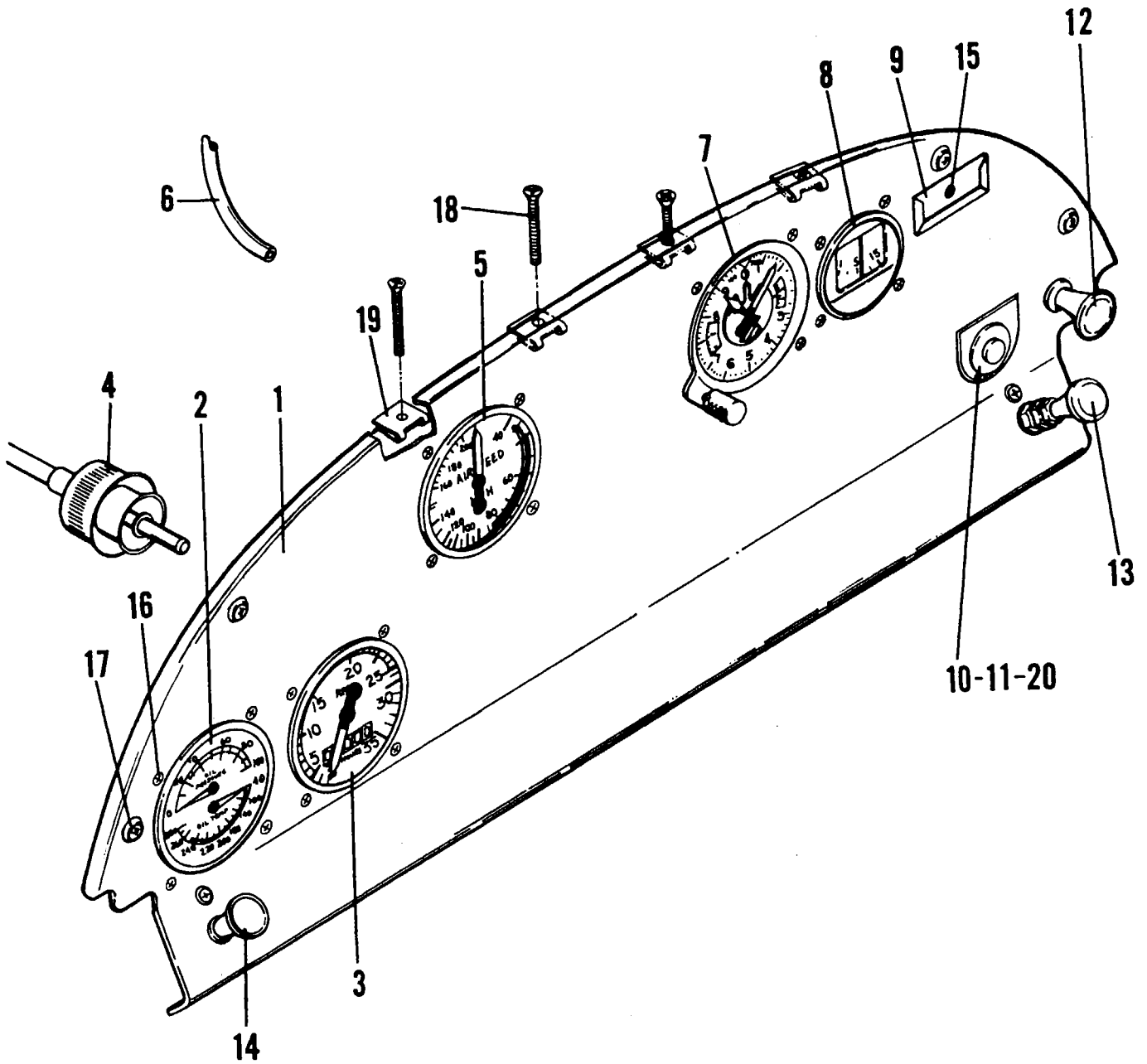

Figure 15 Instrument Panel Installation (Standard)

---

# PIPER PARTS CATALOG

---

## CODE EXPLANATIONS FOR FIGURE 15

A - Washer is positioned against back side of instrument panel

PIPER PARTS CATALOG

Figure and Index Number	Part Number	Code	NOMENCLATURE	No Req.	SERIAL NUMBERS AFFECTED
15-	89227		DRAWING - Instrument Panel Standard Installation		
-1	06161-02		PANEL - Instrument	1	
-2	13416-02		GAUGE ASSEMBLY - Oil temperature and pressure	1	
-3	13621-04		TACHOMETER ASSEMBLY	1	
	62177-03		TACHOMETER ASSEMBLY	1	
-4	486 596		SHAFT - Tachometer	1	
-5	11339-10		INDICATOR ASSEMBLY - Airspeed	1	
-6	13541-04		TUBE - Airspeed	1	
-7	548 330		INDICATOR - Altimeter	1	
-8	450 628		COMPASS	1	
-9	66752-00		CARD - Compass Deviation	1	
-10	487 550		SWITCH - Starter	1	
-11	11015-00		PLACARD - Starter	1	
-12	471 060		KNOB - Cabin air, black	1	
-13	11382-04		PRIMER ASSEMBLY	1	
-14	471 053		KNOB - Mixture control	1	
-15	419 474		SCREW - (MS51861-12)	1	
-16	514 751		SCREW	19	
	406 386		NUT - Tinnerman (A8944-632-24)	AR	
-17	515 714		SCREW	6	
	477 673		NUT	6	
-18	418 581		SCREW - (MS35207-281)	4	
-19	406 355		NUT - Tinnerman (A6052-632-1)	4	
-20	407 142	A	WASHER - (AN936-A1416)	1	

When ordering, always specify Part Number, Description, and Serial Number of Aircraft

---

**PIPER PARTS CATALOG**

---

**THIS PAGE INTENTIONALLY LEFT BLANK**

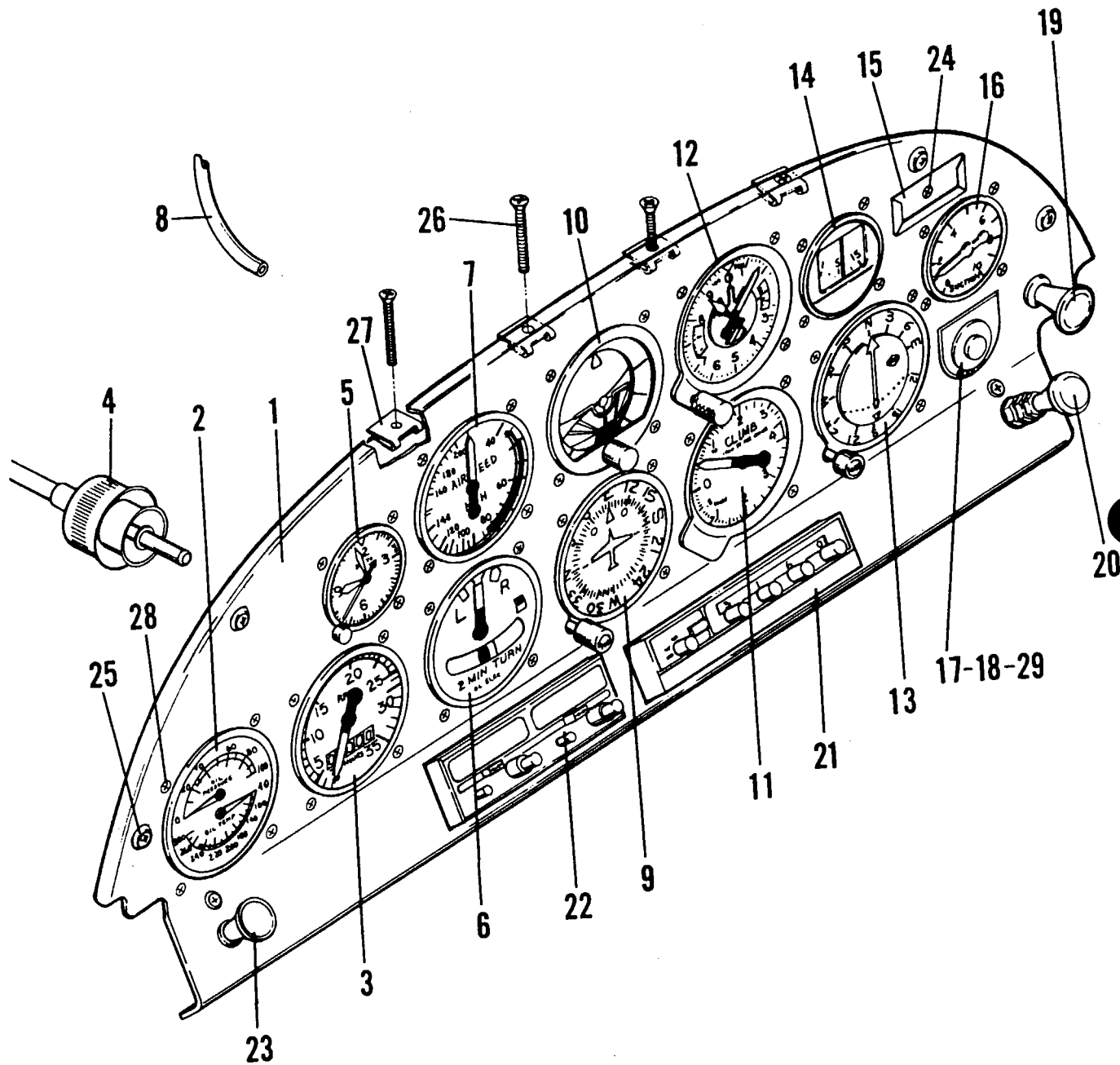

Figure 16 Instrument Panel Installation (With Options)

---

# PIPER PARTS CATALOG

---

## CODE EXPLANATIONS FOR FIGURE 16

A - Optional Nav/Com installations available:

	Piper Code Number
KX-155 Nav/Com Kit (King/Bendix 069-1024-08)	598 242
KI-208 Vor/Loc Indicator Kit (King/Bendix 066-3056-00)	548 292
KT-76A Transponder Kit (King/Bendix 066-1062-00)	596 662
KY-97A Com Transceiver (King/Bendix 064-1051-60)	599 163
MK-12D Nav/Com Kit (Narco 03118-0300)	598 843
ID-824 Vor/Loc Indicator Kit (Narco EL-03749-0300)	598 455
AT-150 Transponder Kit (Narco EL-03606-300)	596 840
Escort IIA Nav/Com Indicator (Narco 03119-0308)	599 164
AR-850 Encoder Kit (Narco 03725-0300)	599 012

B - Washer is positioned against back side of instrument panel

PIPER PARTS CATALOG

Figure and Index Number	Part Number	Code	NOMENCLATURE	No. Req	SERIAL NUMBERS AFFECTED
16-	89227 89225		DRAWING - Instrument Panel Standard Installation DRAWING - Vacuum System Installation		
-1	06161-02		PANEL - Instrument	1	
-2	13416-02		GAUGE ASSEMBLY - Oil temperature and pressure	1	
-3	13621-04		TACHOMETER ASSEMBLY	1	
	62177-03		TACHOMETER ASSEMBLY	1	
-4	486 596		SHAFT - Tachometer	1	
-5	548 868		CLOCK	1	
-6	548 314		INDICATOR - Turn and slip (Vacuum)	1	
	599 178		INDICATOR - Turn and slip (Electric)	1	
-7	11339-10		INDICATOR ASSEMBLY - Airspeed	1	
-8	13541-04		TUBE - Airspeed	1	
-9	99003-08		INDICATOR - Directional gyro	1	
-10	548 459		INDICATOR - Attitude gyro	1	
-11	550 684		INDICATOR - Rate of climb	1	
-12	548 330		INDICATOR - Altimeter	1	
-13		A	INDICATOR - Navigation	1	
-14	450 628		COMPASS	1	
-15	66752-00		CARD - Compass deviation	1	
-16	548 886		GAUGE - Suction	1	
-17	487 550		SWITCH - Starter	1	
-18	11015-00		PLACARD - Starter	1	
-19	471 060		KNOB - Cabin air, black	1	
-20	11382-04		PRIMER ASSEMBLY	1	
-21		A	TRANSPONDER	1	
-22		A	NAV/COM	1	
-23	471 053		KNOB - Mixture control	1	
-24	419 474		SCREW - (MS51861-12)	1	
-25	515 714		SCREW	6	
	477 673		NUT	6	
-26	418 581		SCREW - (MS35207-281)	4	
-27	406 355		NUT - Tinnerman (A6052-632-1)	4	
-28	514 751		SCREW	AR	
	406 386		NUT - Tinnerman (A8944-632-24)	AR	
-29	407 142	B	WASHER - (AN936-A1416)	1	

When ordering, always specify Part Number, Description, and Serial Number of Aircraft



---

**PIPER PARTS CATALOG**

---

**THIS PAGE INTENTIONALLY LEFT BLANK**

# PIPER PARTS CATALOG

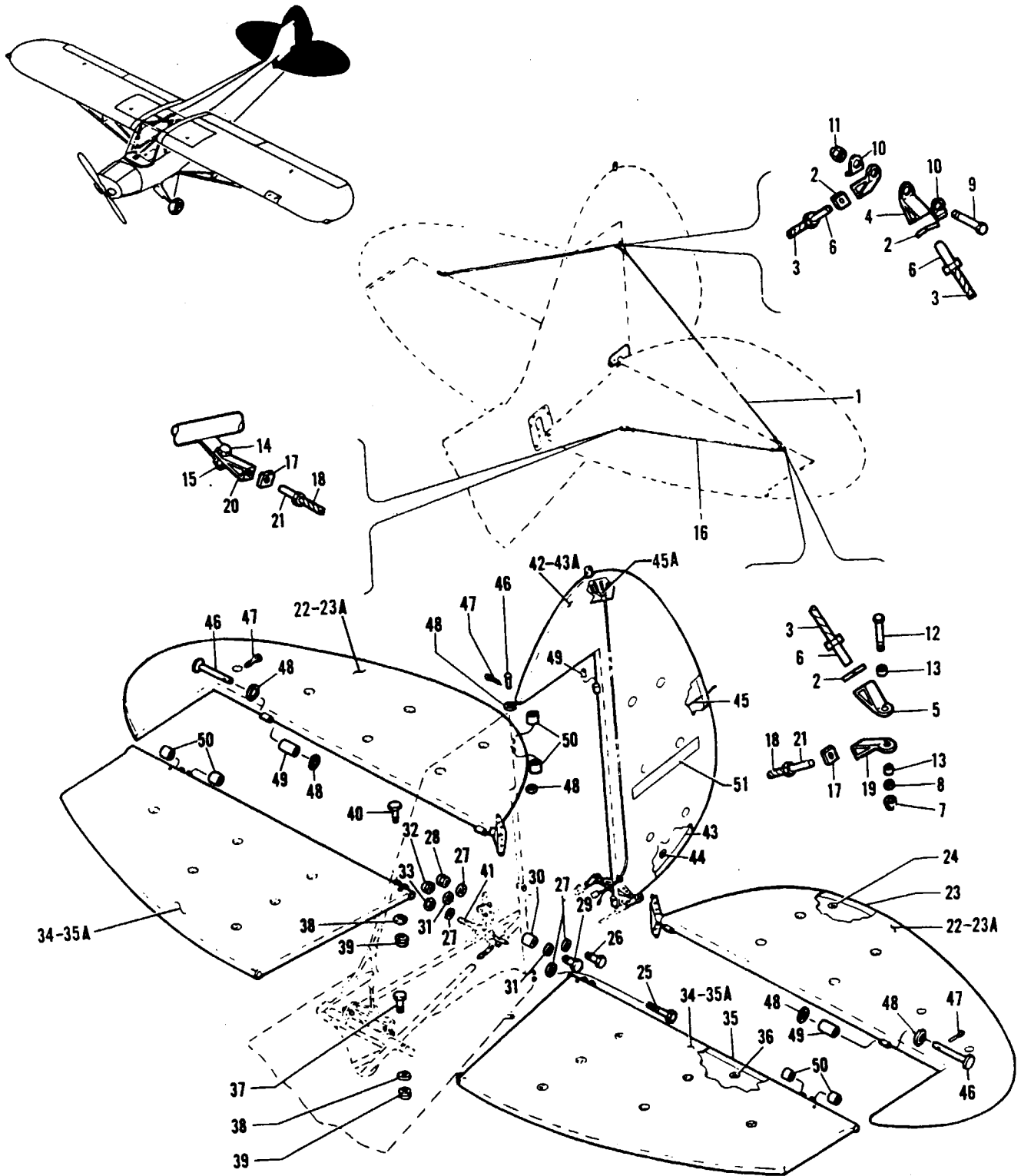

Figure 17 Tail Surface Installation

---

# PIPER PARTS CATALOG

---

CODE EXPLANATIONS FOR FIGURE 17

## PIPER PARTS CATALOG

Figure and Index Number	Part Number	Code	NOMENCLATURE	No. Req.	SERIAL NUMBERS AFFECTED
17-	10918		DRAWING - Tail Surface Installation		
-1	10555-02		WIRE ASSEMBLY - Brace, upper	2	
-2	81102-02		* WASHER - Square	2	
-3	41031-02		* WIRE	1	
-4	61341-03		* CLEVIS	1	
-5	61341-02		* CLEVIS	1	
-6	41051-00		* NIPPLE	2	
-7	406 681		NUT - (No 22M02 elastic stop nut)	2	
-8	407 564		WASHER - (AN960-10)	2	
-9	401 315		BOLT - (AN4-15A)	1	
-10	40131-02		WASHER - Fin tail brace	2	
-11	406 682		NUT - (No 42E028 elastic stop nut)	1	
-12	401 274		BOLT - (AN3-15A)	2	
-13	82732-72		BUSHING	4	
-14	401 266		BOLT - (AN3-5A)	2	
-15	406 681		NUT - (No 22M02 elastic stop nut)	2	
-16	10556-02		WIRE ASSEMBLY - Brace, lower	2	
-17	61342-00		* WASHER - Square	2	
-18	41031-03		* WIRE	1	
-19	61341-04		* CLEVIS	1	
-20	61340-00		* CLEVIS	1	
-21	41051-00		* NIPPLE	2	
-22	12789-04		ELEVATOR ASSEMBLY - Ceconite covered, LH	1	
	12789-05		ELEVATOR ASSEMBLY - Ceconite covered, RH	1	
-23	12770-00		* ELEVATOR ASSEMBLY - Uncovered	1	
-23a	459 132		* ENVELOPE - Elevator Assy, Ceconite (BLU PA-18-E)	1	
-24	80122-53		* GROMMET - (5 per elevator)	5	
-25	400 440		BOLT - (AN3-6A)	1	
-26	401 266		BOLT - (AN3-5A)	1	
-27	407 564		WASHER - (AN960-10)	4	
-28	406 681		NUT - (No 22M02 elastic stop nut)	1	
-29	400 003		BOLT - (AN4-6A)	1	
-30	80012-17		BUSHING	1	
-31	407 565		WASHER - (AN960-416)	2	
-32	406 682		NUT - (No 42E048 elastic stop nut)	1	
-33	404 100		NUT - (AN310-3)	1	
-34	12790-04		STABILIZER ASSEMBLY - Ceconite covered, LH	1	
	12790-05		STABILIZER ASSEMBLY - Ceconite covered, RH	1	
-35	12769-00		* STABILIZER ASSEMBLY - Uncovered	1	
-35a	459 130		* ENVELOPE - Stabilizer Assy, Ceconite (BLU PA-18-ST)	1	
-36	80122-53		* GROMMET - Drain	8	
-37	400 444		BOLT - (AN-3-13A)	2	
-38	407 564		WASHER - (AN960-10)	4	
-39	406 681		NUT - (No 22M02 elastic stop nut)	4	
-40	400 443		BOLT - (AN-3-12A)	2	
-41	86062-79		TUBE - Liner, rear	1	
-42	12573-02		RUDDER ASSEMBLY - Ceconite covered	1	
-43	40622-07		* RUDDER ASSEMBLY - Uncovered	1	
	15726-02		* RUDDER ASSEMBLY - Uncovered (Used with strobe if installed)	1	
-43a	459 133		* ENVELOPE - Rudder Assy, Ceconite (BLU PA-18-R)	1	
-44	80122-53		* GROMMET - Drain (0.75 OD, 0 25 ID)	1	
	85012-106		* WASHER - Drain (1 25 OD, 0 44 ID)	1	
-45	12177-39		* WIRE ASSEMBLY - Tail light	1	
-45a	12177-39		* WIRE ASSEMBLY - Strobe light	1	
-46	424 224		PIN - Hinge (AN394-55)	6	
-47	424 051		PIN - Cotter (AN380-2-2)	6	
-48	80122-86		WASHER	12	
-49	80022-44		BUSHING - Bronze, long	6	
-50	80022-45		BUSHING - Bronze, short	12	
-51	55549-02		DECAL - "Piper"	2	

When ordering, always specify Part Number, Description, and Serial Number of Aircraft

---

**PIPER PARTS CATALOG**

---

**THIS PAGE INTENTIONALLY LEFT BLANK**



---

# PIPER PARTS CATALOG

---

## CODE EXPLANATIONS FOR FIGURE 18

- A - See item 4 for washer, nut, and pin
- B - Refer to figure 20 for complete parts breakdown and description of Cleveland (40-60) Wheel Assembly
- C - Refer to figure 19 for complete parts breakdown and description of Cleveland (30-60) Brake Assembly

## PIPER PARTS CATALOG

Figure and Index Number	Part Number	Code	NOMENCLATURE	No. Req.	SERIAL NUMBERS AFFECTED
18-	14479		DRAWING - Landing Gear Installation		
-1	30602-07		VEE ASSEMBLY - Cabane	1	
-2	401 359		BOLT - (AN5-20A)	2	
	407 567		WASHER - (AN960-616)	4	
	404 889		NUT - (MS20365-524C)	2	
	407 586		WASHER - (AN960-516L)	AR	
-3	400 212	A	BOLT - (AN6-17)	2	
-4	400 213		BOLT - (AN6-20)	2	
	407 567		WASHER - (AN960-616)	4	
	404 103		NUT - (AN310-6)	2	
	424 059		PIN - Cotter (MS24665-283)	2	
-5	14088-02		STRUT ASSEMBLY - Shock, complete (Hydrasorb unit)	2	
-6	14093-00		*PLATE - End, shock cord cover	2	
-7	14094-00		*COVER - Shock cord	2	
-8	434 142		*GROMMET - Upper (AN931-14-20)	2	
-9	434 144		*GROMMET - Lower (AN931-16-22)	2	
-10	12998-03		STRUT ASSEMBLY - Shock	2	
-11	31322-05		*RING - Shock cord 3/4"	2	
-12	12844-04		*TUBE ASSEMBLY - Shock, long	1	
-13	487 558		*STRUT - Shock, short (Hydrasorb)	1	
-14	12845-00		*FITTING ASSEMBLY - Shock strut, upper end	1	
-15	12875-00		*FITTING ASSEMBLY - Shock strut, lower end	1	
-16	85012-57		*WASHER - Bumper, upper	1	
-17	480 691		*PIN	1	
-18	400 220		BOLT - (AN6-27)	1	
	407 567		WASHER - (AN960-616)	2	
	407 587		WASHER - (AN960-616L)	AR	
	404 890		NUT - (MS20365-624C)	1	
-19	400 219		BOLT - (AN6-26)	3	
	407 567		WASHER - (AN960-616)	3	
	407 587		WASHER - (AN960-616L)	AR	
	404 890		NUT - (MS20365-624C)	3	
-20	10032-08		GEAR ASSEMBLY - Landing, Ceconite covered, LH	1	
	10032-07		GEAR ASSEMBLY - Landing, Ceconite covered, RH	1	
-21	459 135		*ENVELOPE - Landing gear assembly, Ceconite (BLU PA-18-L)	1	
-22	10033-06		*GEAR ASSEMBLY - Landing, uncovered, LH	1	
	10033-05		*GEAR ASSEMBLY - Landing, uncovered, RH	1	
-23	80022-63		**BUSHING - Insert	2	
-24	10034-00		**LINE ASSEMBLY - Brake	1	
-25	10748-00		*GROMMET - Landing Gear Vee	1	
-26	81903-03		STEP ASSEMBLY - Landing gear	1	
-27	761 970		TIRE - (6 00 x 6, 4 ply) B F Goodrich	2	
	762 032		TIRE - (6 00 x 6, 4 ply) Goodyear Flight Custom II	2	
	761 994		TIRE - (6 00 x 6, 4 ply) McCreary Airhawk	2	
-28	451 735		TUBE - 6 00 x 6	2	
-29	24918-00		COVER - Wheel	2	
-30	415 531		SCREW - (MS35206-241)	6	
-31	407 120		WASHER - Lock (AN936-B8)	6	
-32	30491-00		NUT - Axle	2	
-33	424 065		PIN - Axle nut	2	
-34	551 771	B	WHEEL ASSEMBLY - (40-60) Cleveland	2	
-35	551 727	C	BRAKE ASSEMBLY - (30-60) Cleveland	2	
-36	400 002		BOLT - (AN4-5A)	8	
	404 888		NUT - (MS20365-428C)	8	
-37	60703-02		LINE ASSEMBLY - Brake	2	
-38	460 677		ELBOW - (400 x 4)	2	
-39	558 819		ELBOW - (502 x 4)	2	

When ordering, always specify Part Number, Description, and Serial Number of Aircraft



---

**PIPER PARTS CATALOG**

**THIS PAGE INTENTIONALLY LEFT BLANK**

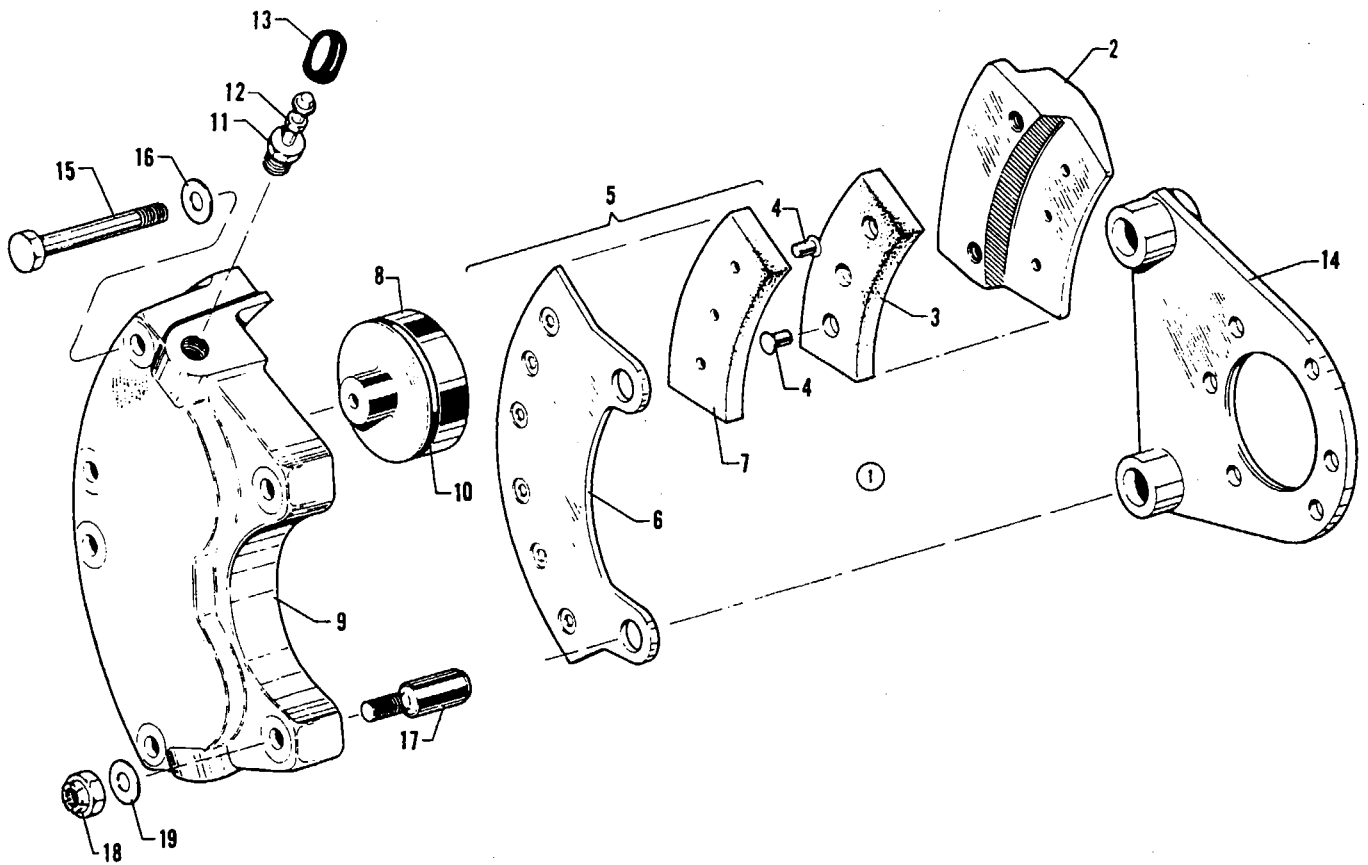

Figure 19 Brake Assembly (Cleveland)

---

# PIPER PARTS CATALOG

---

CODE EXPLANATIONS FOR FIGURE 19

## PIPER PARTS CATALOG

Figure and Index Number	Part Number	Code	NOMENCLATURE	No. Req.	SERIAL NUMBERS AFFECTED
19-1	551 727		BRAKE ASSEMBLY - (Cleveland 30-60)	2	
-2	752 749		*PLATE - Back (64-5)	2	
-3	761 202		*LINING - Back plate (66-56)	2	
-4	752 826		*RIVET - Brake lining (561)	12	
-5	757 488		*PLATE ASSEMBLY - Pressure (73-41)	1	
-6	755 830		**PLATE - Pressure (63-6)	1	
-7	761 203		**LINING - Pressure plate (66-57)	1	
-8	757 491		*PISTON - Cylinder (62-6)	2	
-9	758 095		*CYLINDER - Brake (61-67)	1	
-10	484 698		*PACKING - O-ring (AN6227-27)	2	
-11	752 966		*SEAT - Bleeder (81-1)	1	
-12	752 965		*SCREW - Bleeder (79-3)	1	
-13	753 850		*CAP - Bleeder (183-1)	1	
-14	757 489		*PLATE ASSEMBLY - Torque (75-125)	1	
-15	751 450		*BOLT - (AN4H-15A)	4	
-16	407 585		*WASHER - (AN960-416L)	4	
-17	751 402		*BOLT - Anchor (69-2L)	2	
-18	404 838		*NUT - Anchor (AN3640624)	2	
-19	407 587		*WASHER - Anchor bolt (AN960-616L)	2	

When ordering, always specify Part Number, Description, and Serial Number of Aircraft

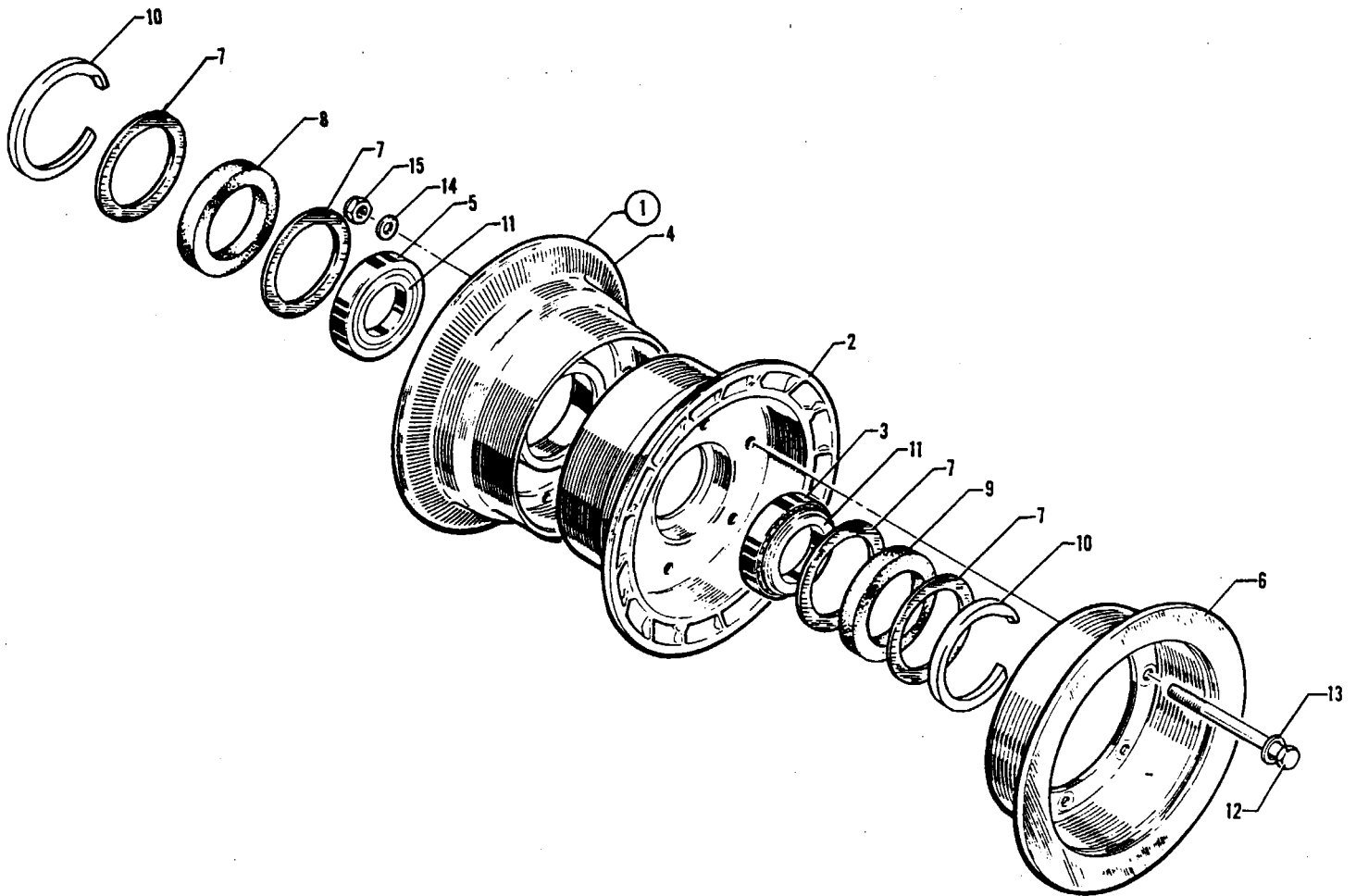

Figure 20 Main Wheel Assembly (Cleveland)

---

# PIPER PARTS CATALOG

CODE EXPLANATIONS FOR FIGURE 20

PIPER PARTS CATALOG

Figure and Index Number	Part Number	Code	NOMENCLATURE	No. Req.	SERIAL NUMBERS AFFECTED
20-1	551 771		WHEEL ASSEMBLY - (Cleveland 40-60)	2	
-2	756 681		* WHEEL HALF ASSEMBLY - Inner (161-70)	1	
-3	757 831		* * CUP - Bearing - (08231)	1	
-4	756 682		* WHEEL HALF ASSEMBLY - Outer (162-65)	1	
-5	757 831		* * CUP - Bearing (08231)	1	
-6	754 615		* DISC ASSEMBLY - Brake (164-67)	1	
-7	762 534		* RING - Grease seal (153-2)	4	
-8	754 849		* FELT - Grease seal, outer wheel (154-2)	1	
-9	754 850		* FELT - Grease seal, inner wheel (154-28)	1	
-10	756 008		* RING - Snap (155-2)	2	
-11	750 063		* BEARING - Cone (08125)	2	
-12	401 334		* BOLT - (AN4-36A)	6	
-13	407 585		* WASHER - (AN960-416L)	6	
-14	407 565		* WASHER - (AN960-416)	6	
-15	404 888		* NUT - (AN365-428)	6	

When ordering, always specify Part Number, Description, and Serial Number of Aircraft

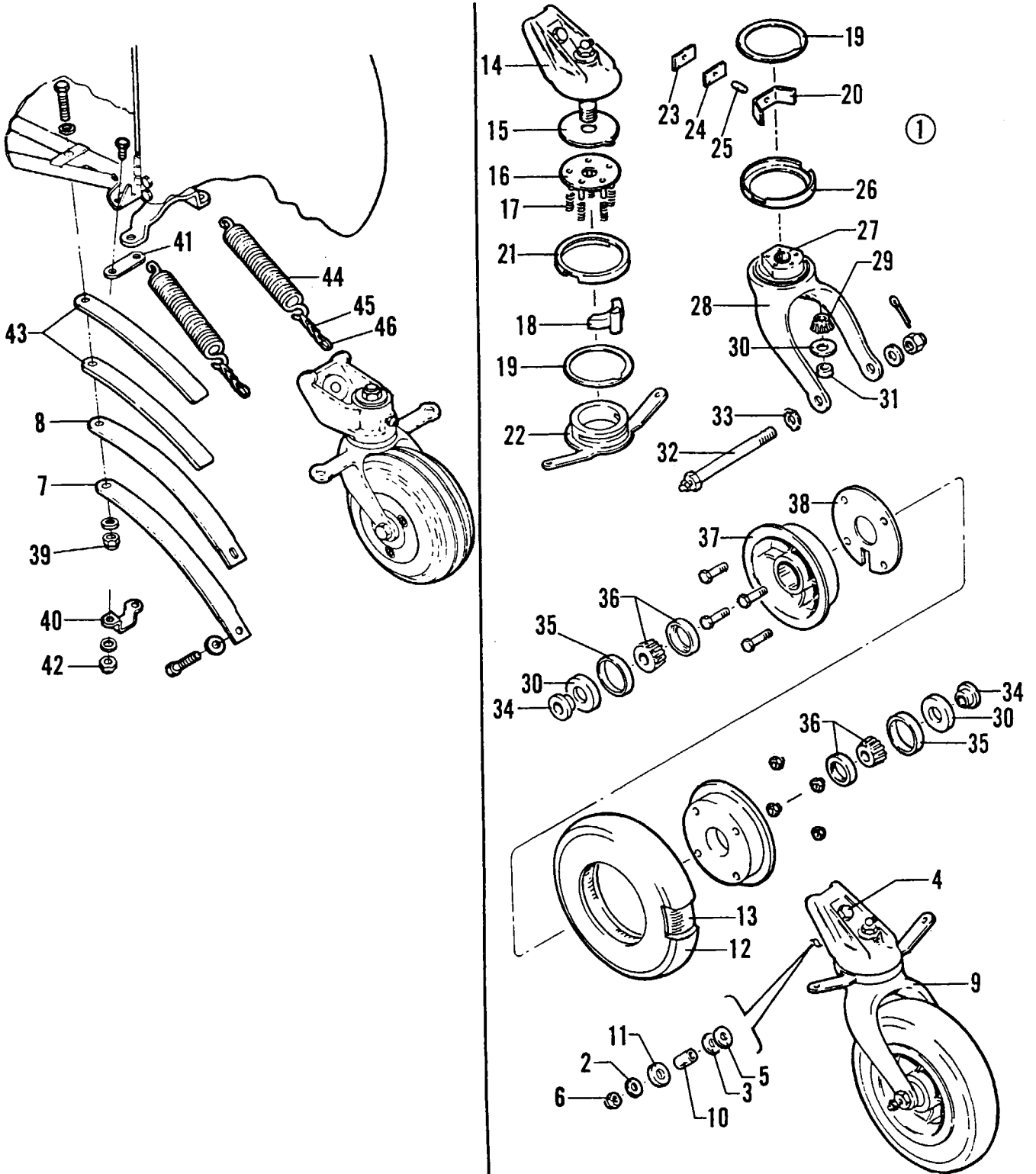

Figure 21 Tail Wheel Installation



---

# PIPER PARTS CATALOG

---

CODE EXPLANATIONS FOR FIGURE 21

## PIPER PARTS CATALOG

Figure and Index Number	Part Number	Code	NOMENCLATURE	No. Req.	SERIAL NUMBERS AFFECTED
21-	13759		DRAWING - Tail wheel installation		
-1	14895-00		TAIL WHEEL ASSEMBLY - Complete	1	
-2	85012-48		*WASHER	1	
-3	80122-30		*WASHER	1	
-4	400 262		*BOLT - (AN7-21)	1	
-5	407 568		*WASHER - (AN960-716)	1	
-6	406 685		*NUT - (#52E070)	1	
-7	10999-05		*SPRING	1	
-8	10999-03		*SPRING	1	
-9	753 127		*TAIL WHEEL ASSEMBLY - (Scott 8", #3200)	1	
-10	751 350		**BUSHING - (#3241-2)	1	
-11	752 888		**SPACER - (#3243-2)	1	
-12	752 982		**TIRE	1	
-13	752 983		**TUBE	1	
-14	753 403		**BRACKET ASSEMBLY - (#3216)	1	
-15	753 207		**WASHER - Thrust (#3207) Micarta	1	
-16	755 880		**PLATE ASSEMBLY - Thrust (#3234)	1	
-17	756 205		**SPRING - Compression (#3233)	5	
-18	755 878		**PAWL - (#3219)	1	
-19	753 208		**WASHER - Thrust (#3206)	2	
-20	756 206		**SPRING - (#3222)	1	
-21	753 914		**DUST CAP - Top (#3235-2)	1	
-22	751 264		**ARM ASSEMBLY - (#3214)	1	
-23	756 207		**SPACER - (#3258-1)	1	
-24	756 208		**SPACER - (#3258)	1	
-25	755 879		**PIN - (#3257)	1	
-26	753 915		**DUST CAP - Bottom (#3235-1)	1	
-27	753 404		**BUSHING - (#3205)	1	
-28	751 806		**FORK ASSEMBLY - (#3224)	1	
-29	753 405		**BEARING - (#A4050)	1	
-30	750 749		**RETAINER - Grease (#1864)	1	
-31	756 209		**SPACER - (#2504-1)	1	
-32	751 265		**AXLE ASSEMBLY - (#3236)	1	
-33	753 209		**WASHER - Lock (#3225)	1	
-34	753 406		**BUSHING - (#3227)	2	
-35	750 750		**RETAINER - (#1862)	2	
-36	750 746		**BEARING ASSEMBLY - (#1883)	2	
-37	751 964		**HUB - (#2598)	2	
-38	756 210		**SPACER - (#2602)	1	
-39	401 405		BOLT - (AN6-25A)	1	
	404 890		NUT - (MS20365-624C)	1	
	407 567		WASHER - (AN960-616)	1	
	80122-41		WASHER	1	
-40	30531-02		CLAMP	1	
-41	30541-02		PAD - Tail spring	1	
-42	400 004		BOLT - (AN4-7A)	2	
	404 888		NUT - (MS20365-428C)	2	
	14977-00		WASHER	2	
-43	12567-04		SPRING	2	
-44	97288-00		SPRING	2	
-45	159 119		CHAIN - (PS10076-1)	2	
-46	472 681		LINK - (PS10075-1)	2	

When ordering, always specify Part Number, Description, and Serial Number of Aircraft

PIPER PARTS CATALOG

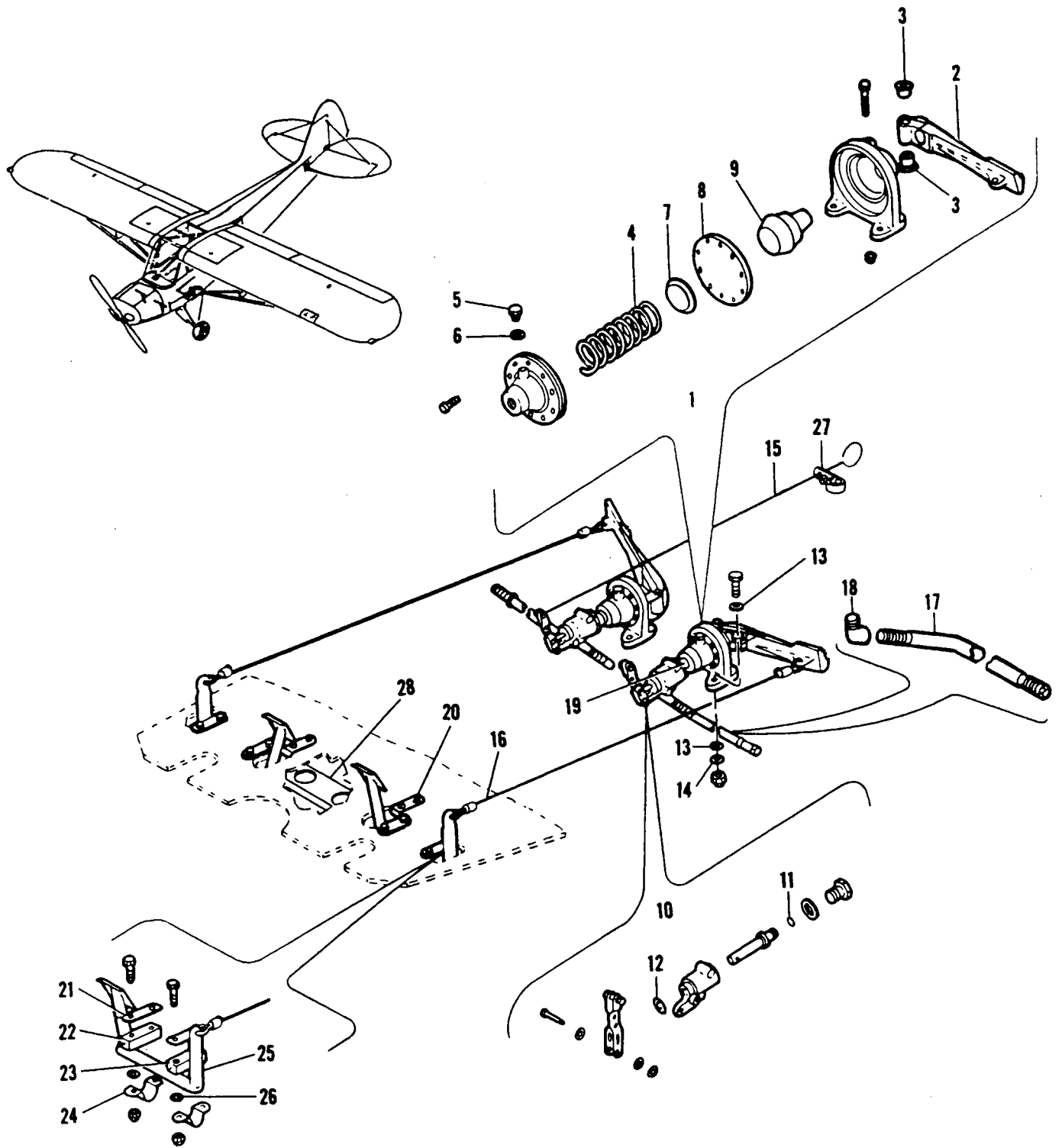

Figure 22 Brake Installation

---

# PIPER PARTS CATALOG

CODE EXPLANATIONS FOR FIGURE 22

PIPER PARTS CATALOG

Figure and Index Number	Part Number	Code	NOMENCLATURE	No Req.	SERIAL NUMBERS AFFECTED
22-	14569		DRAWING - Brake Installation		
-1	451 709		CYLINDER - Master brake, Scott, LH	1	
	451 710		CYLINDER - Master brake, Scott, RH	1	
-2	750 999		*PEDAL - LH (with bushing)	1	
	750 998		*PEDAL - RH (with bushing)	1	
-3	750 997		*BUSHING	2	
-4	750 386		*SPRING	1	
-5	750 387		*SCREW - Vent (B-1258)	1	
-6	750 379		*GASKET - Vent (B-1159)	1	
-7	752 688		*PAD - Diaphragm	1	
-8	750 384		*DIAPHRAGM	1	
-9	750 295		*PISTON	1	
-10	492 023		VALVE - Parking brake (No 4200-A1)	2	
-11	752 791		*RING - "O", 1/4 OD x 1/8" ID (10V70-S7-1)	1	
-12	752 798		*RING - "O", 3/8 OD x 1/4" ID (10V70-S7-5)	1	
-13	80122-11		WASHER	6	
-14	80122-07		WASHER	2	
-15	752 788		ROD - Brake lock control (No 4151)	2	
-16	41581-04		ROD - Tie	2	
-17	71061-04		LINE ASSEMBLY - Flexible	2	
-18	460 663		ELBOW - 45 No 3350 x 2	2	
-19	752 475		NIPPLE - Close, 1/8"	2	
-20	14570-00		PLATE - Heel, cockpit floor, LH	1	
	14570-01		PLATE - Heel, cockpit floor, RH	1	
-21	81262-08		LINK - Pedal	4	
-22	41531-00		BLOCK - Pedal, inner	2	
-23	41521-00		BLOCK - Pedal, outer	2	
-24	80222-03		CLAMP - Pedal	4	
-25	10734-00		PEDAL ASSEMBLY - Brake, LH	1	
	10734-01		PEDAL ASSEMBLY - Brake, RH	1	
-26	85012-04		WASHER - Shim	AR	
-27	751 492		CLAMP - Brake installation (2715-1)	2	
-28	12944-00		CHANNEL - Reinforcement	1	

When ordering, always specify Part Number, Description, and Serial Number of Aircraft

# PIPER PARTS CATALOG

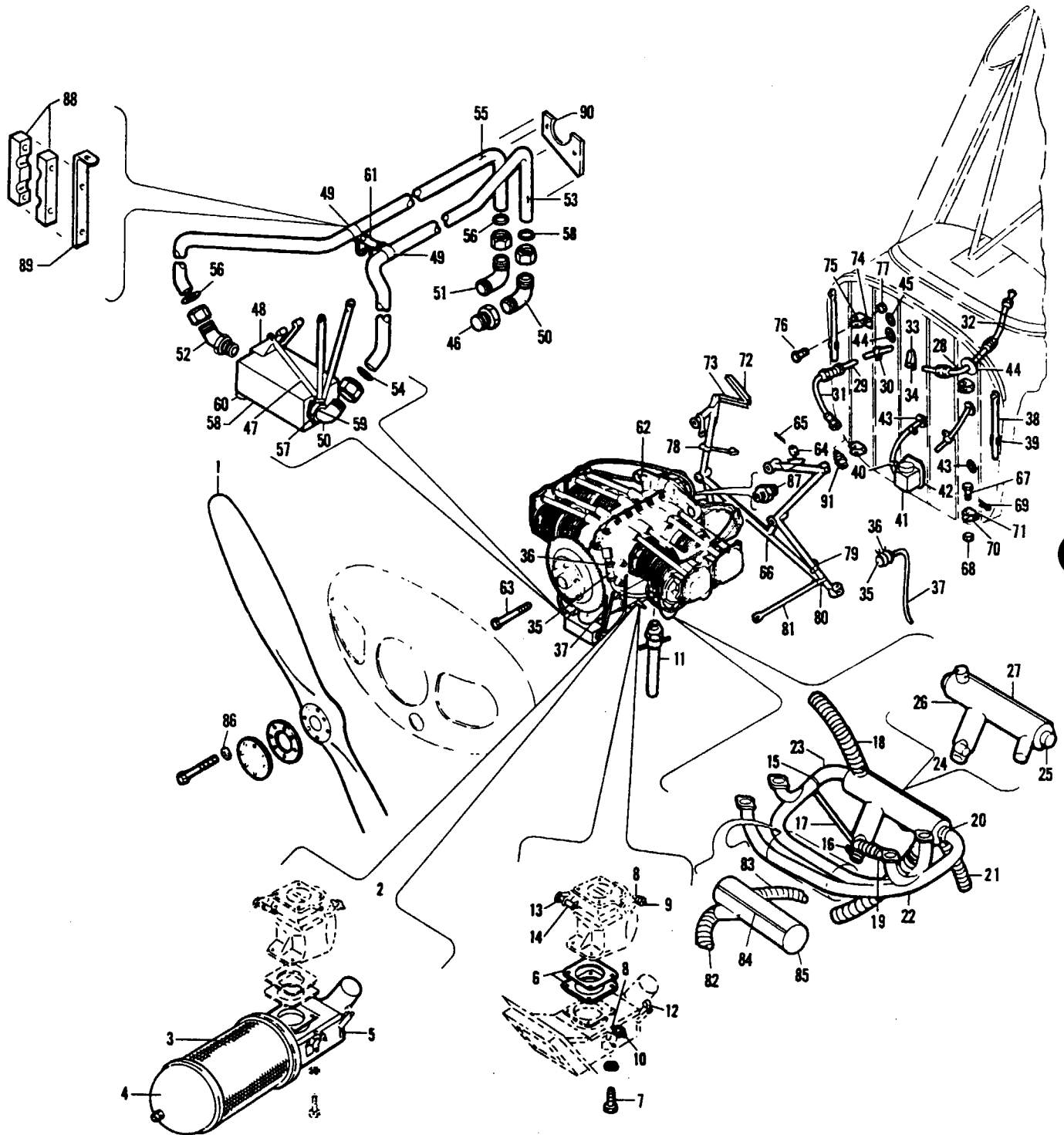

Figure 23 Powerplant Installation, Lycoming

---

# PIPER PARTS CATALOG

---

CODE EXPLANATIONS FOR FIGURE 23

## PIPER PARTS CATALOG

Figure and Index Number	Part Number	Code	NOMENCLATURE	No. Req.	SERIAL NUMBERS AFFECTED
23-	15531 15013		DRAWING - Oil Radiator Installation DRAWING - Powerplant		
-1	450 996		PROPELLER - Sensenich metal, 74DM6-0-56	1	
-2	14444-00		BOX ASSEMBLY - Carburetor air, complete	1	
-3	454 118		CARTRIDGE - Air filter	1	
-4	15007-00		DOME - Carburetor air filter	1	
-5	15005-00		BOX ASSEMBLY - Carburetor air - complete	1	
-6	73451-03		PLATE - Attachment	2	
-7	401 918		BOLT - (MS20074-4-3) Air box to carburetor attachment	4	
-8	91193-00		FITTING - Swivel, mixture control cable attachment	1	
-9	70371-02		FITTING - Swivel, carburetor heat control attachment at carburetor	1	
-10	70371-03		STUD - Mixture and carburetor heat control cable attachment	2	
-11	12956-04		VALVE ASSEMBLY - Oil drain	1	
-12	80032-34		CLAMP - Carburetor heat control cable attachment	1	
-13	82732-08		BUSHING - Spacer, throttle control attachment	1	
-14	80022-68		BUSHING - Spacer, throttle control attachment	1	
-15	10466-21		CLAMP - Tail pipe support, top	1	
-16	10466-33		CLAMP - Tail pipe support tube installation, bottom	1	
-17	13003-00		TUBE - Tail pipe support	1	
-18	101 980		TUBE - Flexible, aluminum 2 1/8" OD	27"	
	10525-32		HOSE - Right rear baffle to muffler shroud	1	
-19	10525-18		HOSE - Tail pipe shroud to carburetor air box	1	
-20	14235-00		CLAMP ASSEMBLY - Exhaust stack and muffler attachment	2	
-21	10525-18		HOSE - Muffler to cabin heater	1	
-22	12457-12		STACK ASSEMBLY - Front cylinders	1	
-23	12457-13		STACK ASSEMBLY - Rear cylinders	1	
-24	14434-02		MUFFLER ASSEMBLY - Complete	1	
-25	12433-14		*MUFFLER ASSEMBLY - Less shroud	1	
-26	12436-10		*SHROUD - Muffler	1	
-27	71261-05		*CLIP ASSEMBLY - Shroud	1	
-28	15216-00		HOSE ASSEMBLY - Flexible, oil pressure	1	
-29	82332-26		TUBE ASSEMBLY - Non-flexible, oil pressure	1	
-30	80032-51		CLAMP - Attachment, oil pressure line	1	
-31	63901-144		HOSE - Flexible, oil pressure line	1	
-32	82332-38		TUBE ASSEMBLY - Non-flexible, oil pressure line 13-1/2" L	1	
-33	454 890		CLIP - Tinnerman (No A2828-022-16) throttle control cable on firewall	1	
-34	14174-00		ANGLE - Support throttle control cable	1	
-35	82371-56		HOSE - Flexible, engine breather line connector	1	
-36	554 947		CLAMP - (SAE TY F-10SS) Oil breather line	2	
-37	14441-00		TUBE - Engine breather	1	
-38	12414-00		TUBE - Hold up, cowl side	1	
-39	454 873		CLIP - Cowl hold up tube	2	
-40	454 887		CLAMP - Tinnerman, cabin heat and mixture control cable	5	
	454 927		CLAMP - Tinnerman, (A4980S-2-91) primer line attachment	4	
-41	12353-00		BOX ASSEMBLY - Cabin heat	1	
-42	12440-00		PLATE - Inside firewall	1	

When ordering, always specify Part Number, Description, and Serial Number of Aircraft



PIPER PARTS CATALOG

Figure and Index Number	Part Number	Code	NOMENCLATURE	No. Req.	SERIAL NUMBERS AFFECTED
23-43	434 134		GROMMET - Rubber (AN931-6-10) Carburetor and cabin heat control	2	
-44	434 142		GROMMET - Rubber (AN931-14-20) Tachometer shaft, throttle mixture control	3	
-45	434 134		GROMMET - Rubber (AN931-6-10) Air vent control cable	1	
-46	451 855		ADAPTER - (W/H 3200 x 6)	1	
-47	13725-07		BRACKET ASSEMBLY - Oil radiator support, LH	1	
-48	13720-04		BRACKET ASSEMBLY - Oil radiator support, RH	1	
-49	454 933		CLAMP - Tinnerman (A409-S-8-91) bracket attachment	2	
-50	458 931		ELBOW - (No 905-8B)	2	
-51	458 898		ELBOW - (AN822-8D)	1	
-52	458 932		ELBOW - (No 1100-8)	1	
	476 664		NIPPLE - (AN816-8D)	1	
-53	60726-02		LINE ASSEMBLY - Oil cooler, left, outlet	1	
-54	484 654		RING - Seal	2	
-55	14624-00		LINE ASSEMBLY - Oil cooler, right, inlet	1	
	39995-35		HOSE ASSEMBLY - Oil cooler, right, inlet	1	
-56	484 654		RING - Seal	2	
-57	13726-00		PLATE - Lock	2	
-58	14206-00		RADIATOR - Oil cooler, 12 plate (PAC No 455 168)	1	
-59	752 494		NUT - Oil radiator	2	
-60	453 647		BUMPER - Oil radiator, snap in (4235)	4	
-61	14549-00		BRACKET - Line support, oil radiator	1	
-62			ENGINE - Lycoming (O-320)	1	
-63	400 321		BOLT - (AN8-44)	4	
-64	404 105		NUT - (AN310-8)	4	
-65	424 059		PIN - Cotter (AN380-3-3)	4	
-66	12351-15		MOUNT ASSEMBLY - Engine	1	
-67	400 211		BOLT - (AN6-16)	4	
-68	404 103		NUT - (AN310-6)	4	
-69	424 059		PIN - Cotter (AN380-3-3)	4	
-70	81102-17		WASHER - Attachment, steel	4	
-71	80122-43		WASHER - Attachment, fibre	3	
-72	12411-02		HINGE - Motor mount, rear	1	
-73	12410-00		HINGE - Motor mount, front	1	
-74	12409-00		LUG - Hinge attachment	1	
-75	12213-00		BRACKET ASSEMBLY - "U"	4	
-76	401 400		BOLT - (AN6-20A)	4	
-77	406 683		NUT - Elastic stop (42E054)	4	
-78	12408-00		CLAMP ASSEMBLY - Throttle control	1	
-79	12407-00		CLAMP ASSEMBLY - Mixture control	1	
-80	80002-27		CLAMP - Cowl support tube	2	
-81	12350-00		TUBE - Cowl support	2	
-82	10525-14		HOSE - Exhaust stack shroud to bottom cowl	1	
-83	10525-19		HOSE - Exhaust stack shroud to muffler shroud	1	
-84	71261-07		CLIP - Shroud, exhaust stack	1	
-85	14239-00		SHROUD - Exhaust stack	1	
-86	80122-55		WASHER - Attaching propeller	6	
-87	455 158		CONNECTOR - Male, oil outlet port (500 x 8)	1	
-88	15020-00		BLOCK - Line attachment	2	
-89	15019-00		BRACKET - Baffle reinforcement	1	
-90	15530-02		PLATE - Baffle reinforcement	1	
-91	89240-02		ADAPTER- Restrictor, oil pressure	1	

When ordering, always specify Part Number, Description, and Serial Number of Aircraft

---

**PIPER PARTS CATALOG**

**THIS PAGE INTENTIONALLY LEFT BLANK**

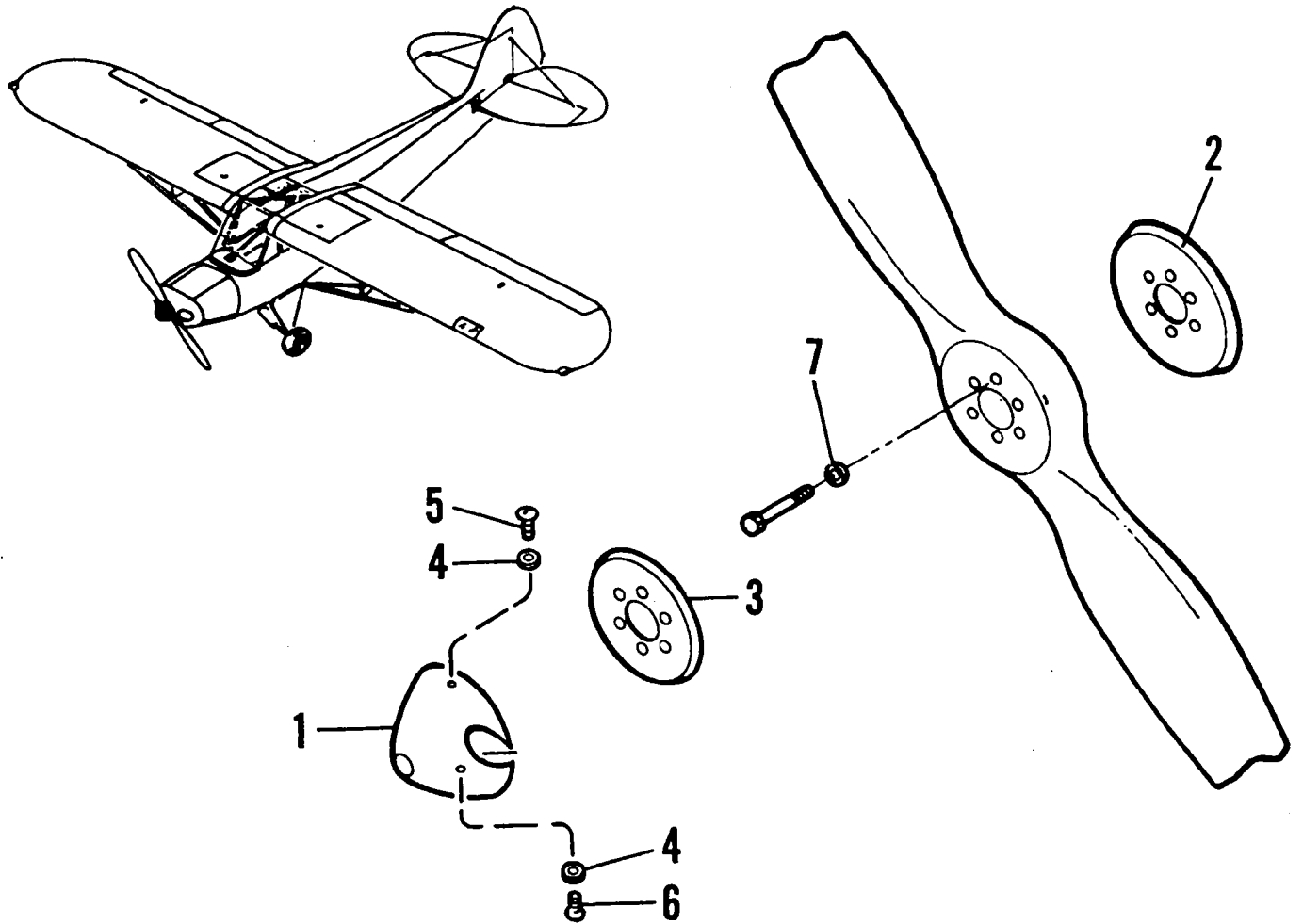

Figure 24 Spinner Installation

---

# PIPER PARTS CATALOG

CODE EXPLANATIONS FOR FIGURE 24

PIPER PARTS CATALOG

Figure and Index Number	Part Number	Code	NOMENCLATURE	No Req	SERIAL NUMBERS AFFECTED
24-1	14422-00		SPINNER ASSEMBLY - (Sensenich metal propeller)	1	
-2	14424-00		PLATE - Rear (Sensenich metal propeller)	1	
-3	14426-00		PLATE - Front (Sensenich metal propeller)	1	
-4	85012-47		WASHER - Fibre (10 per ship)	10	
-5	416 995		SCREW - Machine truss head (No 10-32 x 1/2")	6	
-6	416 995		SCREW - Machine truss head (No 10-32 x 1/2")	4	
-7	80122-55		WASHER - Propeller bolt attachment	6	

When ordering, always specify Part Number, Description, and Serial Number of Aircraft

# PIPER PARTS CATALOG

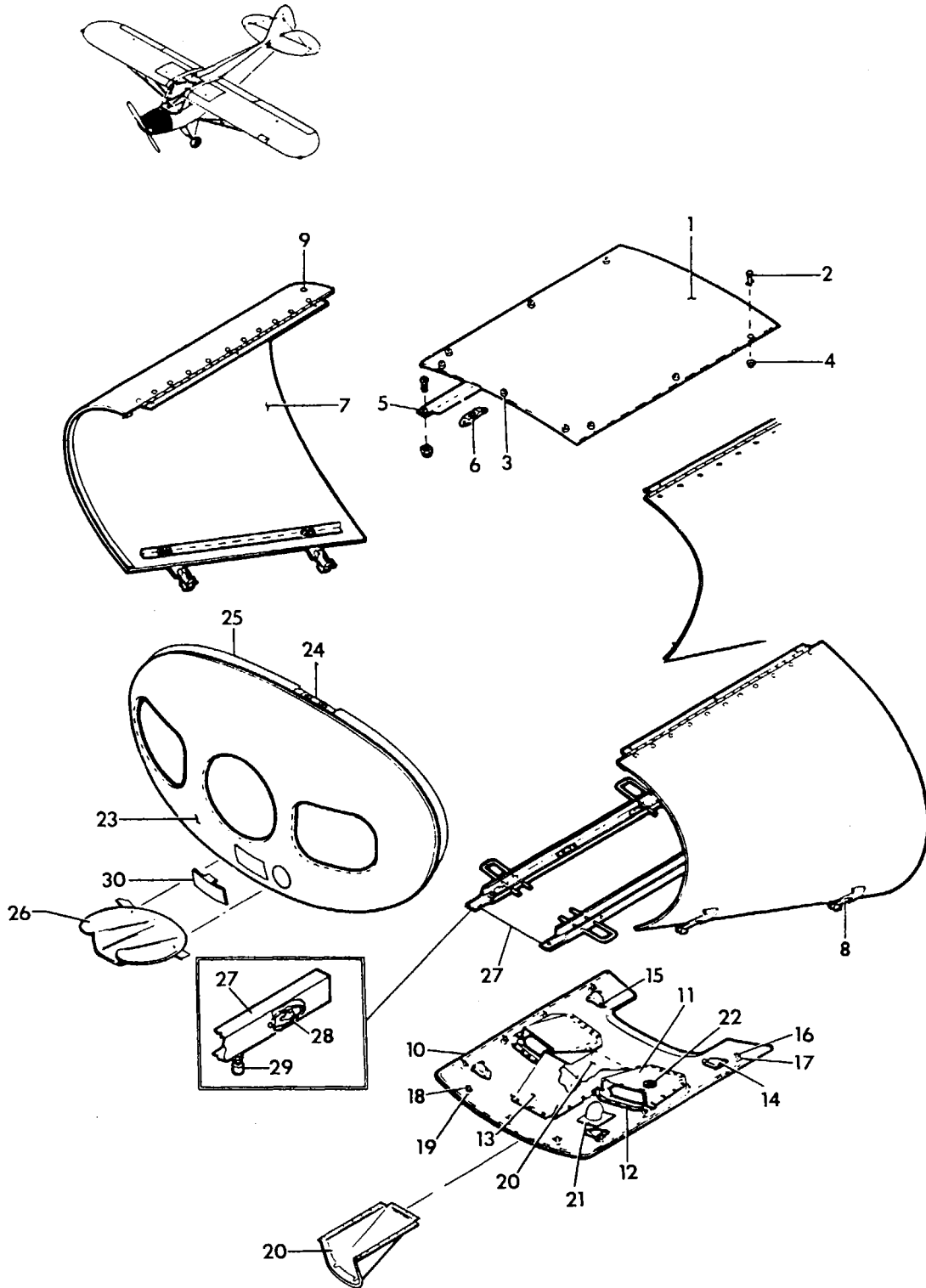

Figure 25 Cowl Installation, Lycoming

---

# PIPER PARTS CATALOG

---

CODE EXPLANATIONS FOR FIGURE 25

### PIPER PARTS CATALOG

Figure and Index Number	Part Number	Code	NOMENCLATURE	No Req.	SERIAL NUMBERS AFFECTED
25-1	12356-03		COWL ASSEMBLY - Top	1	
-2	487 563		* STUD - Fastener (No 5-0-140A)	6	
-3	487 565		* STUD - Fastener (No 5-0-200A) Front	3	
-4	463 368		* GROMMET - (No GOS-5-93)	9	
-5	12362-03		BRACKET - Cowl mounting, top	2	
-6	487 288		* SPRING - Stud fastener	3	
-7	13029-00		COWL ASSEMBLY - Side, LH	1	
	13029-01		COWL ASSEMBLY - Side, RH	1	
-8	12723-04		* FASTENER ASSEMBLY	2	
-9	12360-00		* STUD - Cowl stop	1	
-10	15012-00		COWL ASSEMBLY - Engine, bottom	1	
-11	15008-00		* PLATE - Vent (less oil drain hole) LH	1	
	15008-01		* PLATE - Vent (with oil drain hole), RH	1	
-12	15018-00		* FLANGE - Vent, outside	2	
-13	15010-00		* SCOOP - Carburetor air	1	
-14	12707-00		* CUP - Cowl fastener	4	
-15	484 341		* RECEPTACLE - Cowl fastener	4	
-16	487 566		* STUD - Cowl fastener, side (No 5-F-60)	8	
-17	463 369		* GROMMET - Sides (No GF-150)	8	
-18	487 565		* STUD - Cowl fastener, front (No 5-0-200A)	3	
-19	463 368		* GROMMET - Front (No GOS-5-93)	3	
-20	15009-00		* SCOOP - Carburetor air, outside	1	
-21	14236-00		* SCOOP ASSEMBLY - Air	1	
-22	434 142		* GROMMET - Oil drain (AN931-14-20)	1	
-23	13716-00		COWL ASSEMBLY - Nose	1	
-24	487 288		* SPRING - (No 5-295)	7	
-25	180 808		* WEBBING - Cowl	6	
-26	13717-00		* SCOOP ASSEMBLY - Nose cowl air	1	
-27	12364-03		CHANNEL ASSEMBLY - Cowl lower mounting, LH	1	
	12364-05		CHANNEL ASSEMBLY - Cowl lower mounting, RH	1	
-28	487 288		* SPRING - Stud fastener	4	
-29	453 640		* TIP - Rubber	1	
-30	14073-00		COVER - Radiator, nose cowl	1	

When ordering, always specify Part Number, Description, and Serial Number of Aircraft



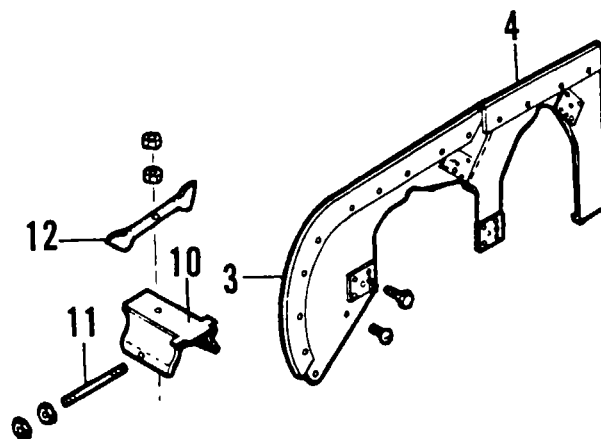
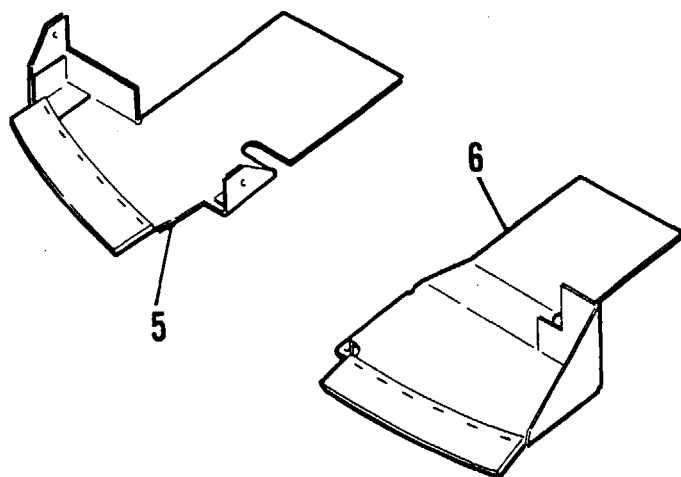
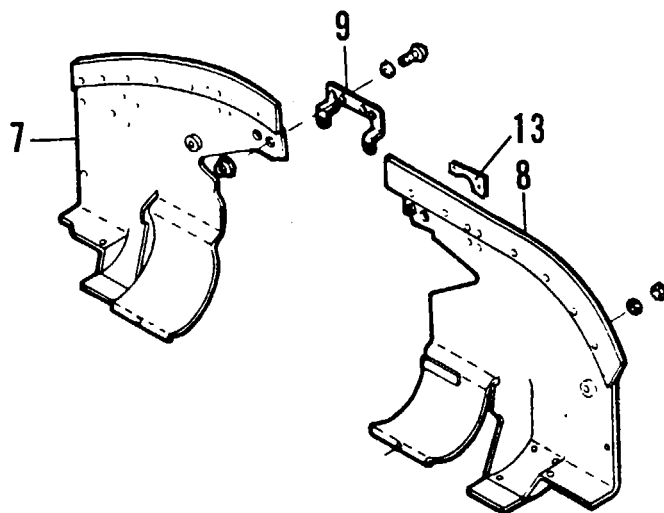
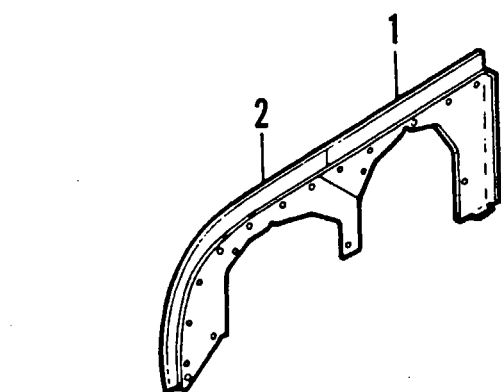
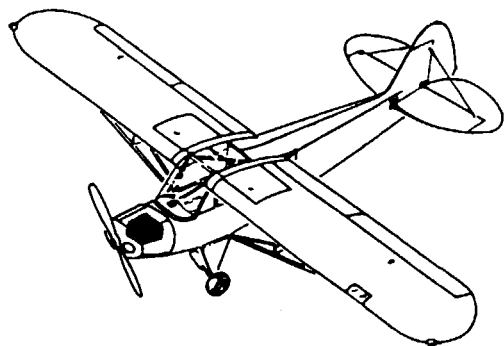

Figure 26 Baffles Installation

---

# PIPER PARTS CATALOG

CODE EXPLANATIONS FOR FIGURE 26

PIPER PARTS CATALOG

Figure and Index Number	Part Number	Code	NOMENCLATURE	No. Req.	SERIAL NUMBERS AFFECTED
26-1	14455-00		BAFFLE - Engine, side, right rear	1	
-2	14456-00		BAFFLE - Engine, side, right front	1	
-3	14452-00		BAFFLE - Engine, side, left front	1	
-4	14457-00		BAFFLE - Engine, side, left rear	1	
-5	15529-02		BAFFLE ASSEMBLY - Front right	2	
-6	14440-00		BAFFLE - Engine, left front	1	
-7	14458-05		BAFFLE ASSEMBLY - Engine, right rear	1	
-8	14467-07		BAFFLE - Engine, left rear	1	
-9	10175-00		BRACKET - Rear baffle support	1	
-10	74912-00		BAFFLE - Intercylinder	2	
-11	14513-00		ROD - Tie, connecting front and rear baffles	2	
-12	10415-03		SUPPORT - Intercylinder baffle hanger	2	
-13	15530-02		PLATE - Baffle reinforcement	1	

When ordering, always specify Part Number, Description, and Serial Number of Aircraft

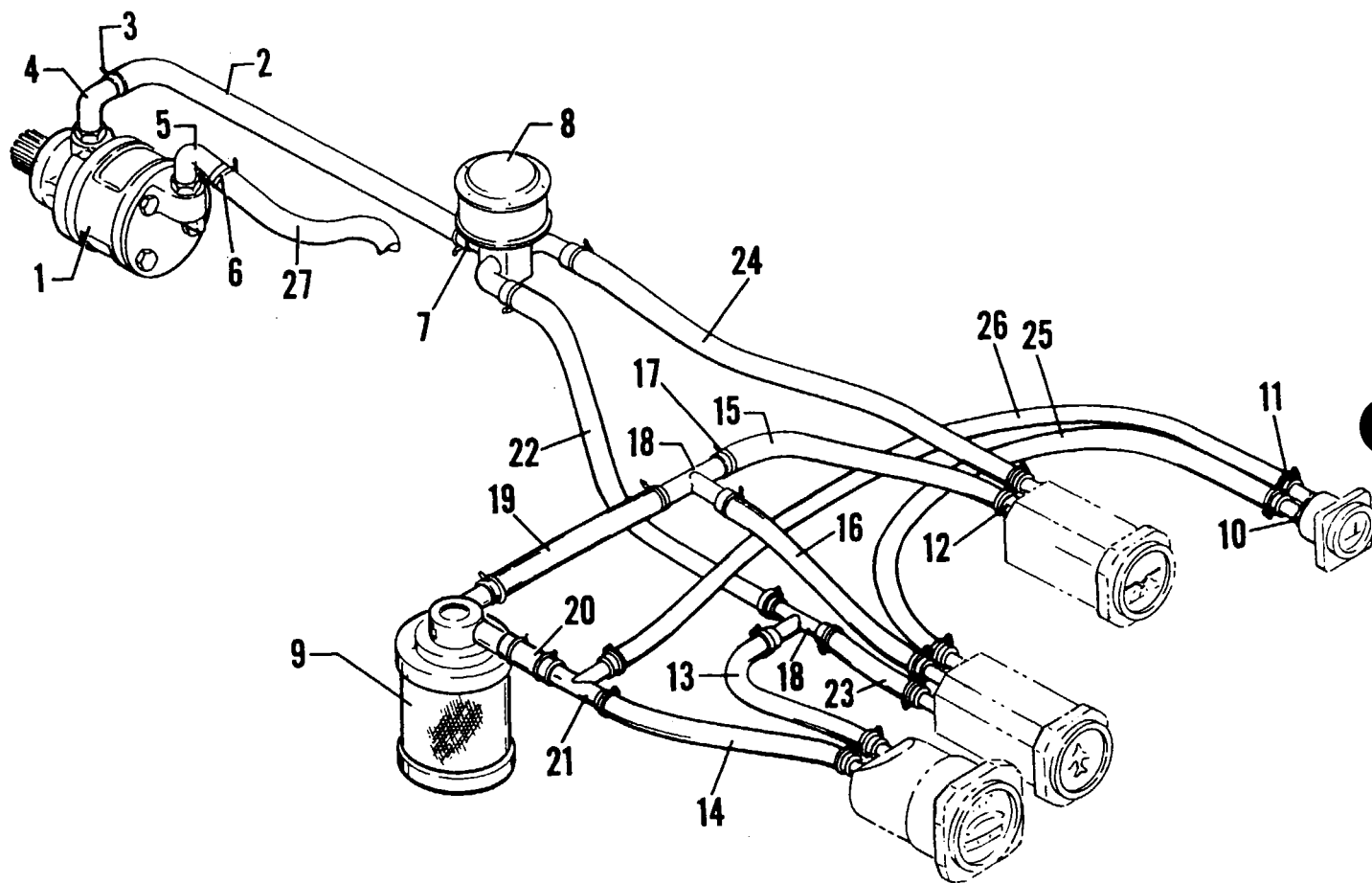

Figure 27 Vacuum System Installation

---

# PIPER PARTS CATALOG

---

CODE EXPLANATIONS FOR FIGURE 27

PIPER PARTS CATALOG

Figure and Index Number	Part Number	Code	NOMENCLATURE	No Req.	SERIAL NUMBERS AFFECTED
27-	89225		DRAWING - Vacuum System Installation		
-1	79399-00		PUMP - Vacuum (ARM211CC)	1	
-2	61541-36		HOSE - Vacuum pump to suction regulator	1	
-3	554 802		CLAMP - Hose (SAE-TY-E-14)	2	
-4	458 958		ELBOW - (1K1-6-10)	1	
-5	558 900		ELBOW - (1K8-6-8)	1	
-6	454 987		CLAMP - Hose (SAE-TY-E-12)	1	
-7	485 080		O-RING - (PRS2210V74775)	1	
-8	492 272		VALVE - Suction regulator (ARM2H3-23)	1	
-9	25230-00		FILTER - Air (PAC 460 798)	1	
	66673-00		FILTER - Air (PAC 460 888)	1	
-10	451 881		FITTING - (1K10-2-4)	3	
-11	454 983		CLAMP - Hose (SAE-TY-E-8)	4	
-12	558 913		ELBOW - (1K9-4-6)	4	
-13	84013-107		HOSE - Tee fitting to turn and bank	1	
-14	84013-106		HOSE - Tee fitting to turn and bank	1	
-15	84013-102		HOSE - Tee fitting to attitude gyro	1	
-16	84013-103		HOSE - Tee fitting to directional gyro	1	
-17	454 832		CLAMP - Hose (SAE-TY-E-10)	18	
-18	588 428		FITTING - Tee (1K14-6-6-6)	2	
-19	84013-104		HOSE - Air filter to tee fitting	1	
-20	84013-105		HOSE - Air filter to tee fitting	1	
-21	588 567		FITTING - Tee (1K30-6-4-6)	1	
-22	84013-108		HOSE - Suction regulator valve to tee fitting	1	
-23	84013-109		HOSE - Tee fitting to directional gyro	1	
-24	84013-101		HOSE - Suction regulator valve to attitude gyro	1	
-25	69015-77		HOSE - Directional gyro to suction gauge	1	
-26	69015-78		HOSE - Tee fitting to suction gauge	1	
-27	82371-90		HOSE - Vacuum pump air exhaust	1	

When ordering, always specify Part Number, Description, and Serial Number of Aircraft

---

**PIPER PARTS CATALOG**

---

**THIS PAGE INTENTIONALLY LEFT BLANK**

# PIPER PARTS CATALOG

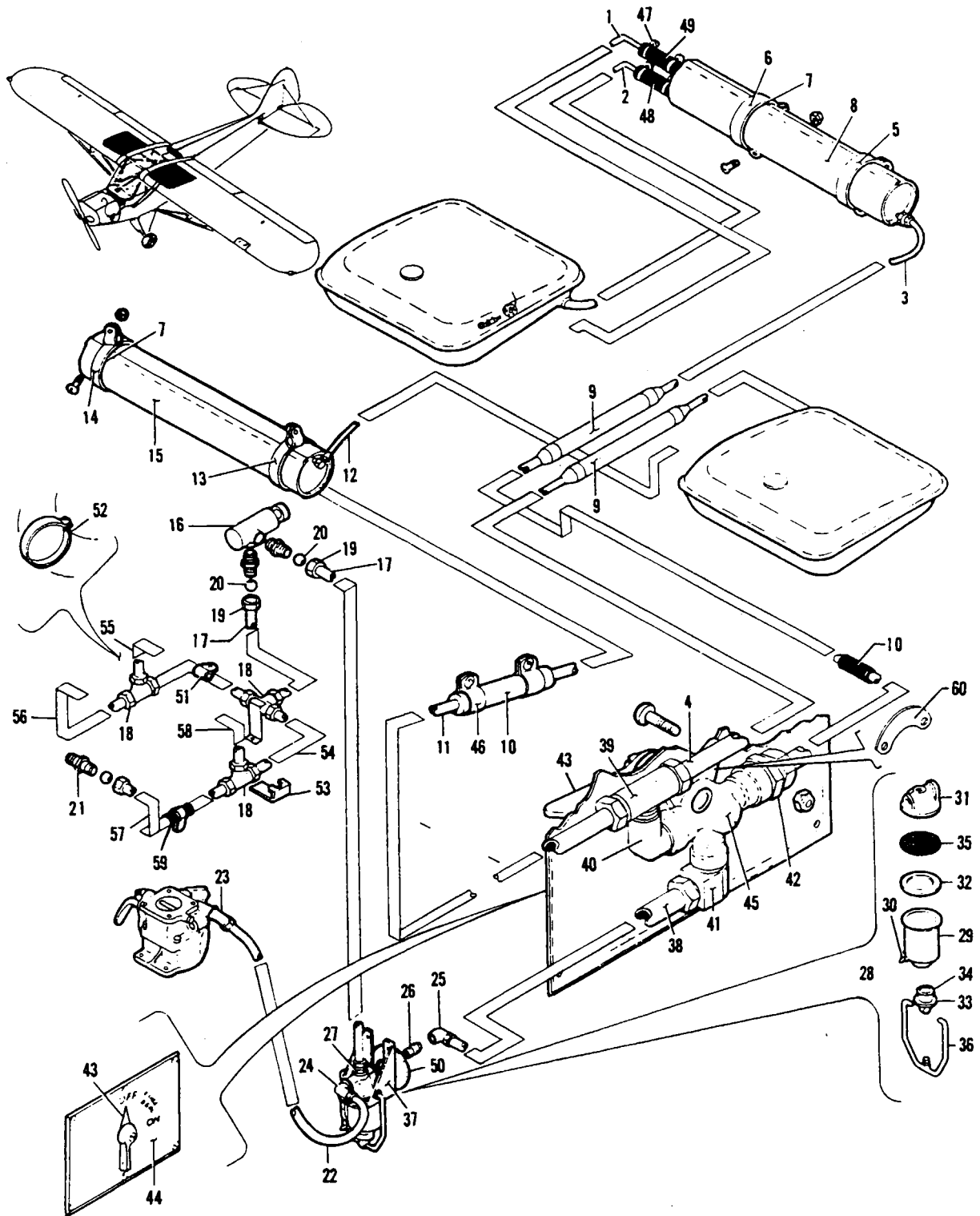

Figure 28 Fuel System Installation



---

# PIPER PARTS CATALOG

---

CODE EXPLANATIONS FOR FIGURE 28

**PIPER PARTS CATALOG**

Figure and Index Number	Part Number	Code	NOMENCLATURE	No. Req	SERIAL NUMBERS AFFECTED
28-	14469 13766		DRAWING - Fuel System Installation DRAWING - Fuel Tank Installation - Wing Installation		
-1	14207-00		LINE ASSEMBLY - Vent, top of fuel gauge to rear header tank (right tank)	1	
-2	14208-00		LINE ASSEMBLY - Fuel, rear of right wing tank to rear header tank	1	
-3	14209-00		LINE ASSEMBLY - Fuel, rear header tank to fuel valve	1	
-4	11300-03		LINE ASSEMBLY - Fuel	2	
-5	12836-02		CLAMP - Rear header tank, LH	1	
-6	12836-03		CLAMP - Rear header tank, RH	1	
-7	180 497		FELT - SAE F-50, header tank clamp	19"	
-8	14211-00		TANK ASSEMBLY - Header, rear	1	
-9	189 534		DUCT - Plane, 563" x 10"	1	
-10	82371-04		HOSE - Flexible	2	
-11	11987-15		LINE ASSEMBLY - Fuel	1	
-12	11987-23		LINE ASSEMBLY - Vent	1	
-13	11299-02		CLAMP ASSEMBLY - Header tank, LH	1	
-14	11299-03		CLAMP ASSEMBLY - Header tank, RH	1	
-15	60763-02		TANK ASSEMBLY - Header, front	1	
-16	451 103		PUMP - Primer, Kohler (K-2406-SAE-2)	1	
-17	10143-63 10143-97		LINE ASSEMBLY - Primer outlet (44" long) LINE ASSEMBLY - Primer inlet (55" long)	1 1	
-18	460 652		TEE - Primer line, W/H 702 x 2	3	
-19	460 684		FITTING - Compression nut W/H No W61 x 2 (with Kohler primer pump)	2	
-20	460 683		FITTING - Compression sleeve, W/H No W60 x 2 (with Kohler primer pump)	2	
-21	468 340		JET - Primer, (4) per ship	4	
-22	17766-65		LINE ASSEMBLY - Fuel	1	
-23	460 659 458 892		ELBOW - W/H No 352 x 6 x 45 ELBOW - (AN823-6D)	1 1	
-24	460 661 458 895		ELBOW - Street, W/H No 3400 x 4 ELBOW - (AN822-6D)	1 1	
-25	460 689		ELBOW - Female inverted, W/H No 450 x 6	1	
-26	476 640		NIPPLE - ¼ NPT Brass	1	
-27	460 651		CONNECTOR - Inverted, W/H No 200 x 2	1	
-28	15225-03		STRAINER ASSEMBLY - Fuel, E-Z drain	1	
-29	12764-00		* BOWL - Fuel strainer, E-Z drain	1	
-30	492 022		* * DRAIN - (E-Z)	1	
-31	14428-00		* COVER - Fuel strainer	1	
-32	85012-32		* GASKET - Fuel strainer	1	
-33	72302-03		* NUT - Fuel strainer bowl seat	1	
-34	750 273		* SEAT - Fuel strainer bowl	1	
-35	750 272		* SCREEN - Fuel strainer	1	
-36	60765-02		* WIRE ASSEMBLY - Bail, nut and seat	1	
-37	71991-00		BRACKET ASSEMBLY - Fuel strainer mounting	1	
-38	10729-03		LINE ASSEMBLY - Fuel	1	
-39	488 374		TEE - Inverted, W/H No 600 x 6	1	
-40	460 661		ELBOW - Street, W/H No 3400 x 4	1	
-41	460 654		ELBOW - W/H 400 x 6	1	
-42	460 653		CONNECTOR - Inverted, W/H No 200 x 6	1	
-43	61964-02		HANDLE ASSEMBLY - Selector ON and OFF	1	
-44	12838-02		PLATE - Fuel ON and OFF indicator	1	
-45	491 947		VALVE - Fuel Selector (AAT6S122)	1	

When ordering, always specify Part Number, Description, and Serial Number of Aircraft

PIPER PARTS CATALOG

Figure and Index Number	Part Number	Code	NOMENCLATURE	No. Req.	SERIAL NUMBERS AFFECTED
28-46	554 871		CLAMP - (SAE TY F-6SS)	2	
-47	554 778		CLAMP - (SAE TY F-4SS)	2	
-48	82371-36		HOSE - Fuel lines to rear header tank	2	
-49	82371-37		HOSE - Vent line to rear header tank	1	
-50	434 132		WASHER - Fuel line installation (MS35489-19)	1	
-51	80032-69		CLAMP - Primer lines attachment on engine	4	
-52	18307-00		CLAMP - Primer line attachment to intake manifold tubes, right and left	2	
-53	14470-00		BRACKET - Mounting, primer line tees	3	
-54	11987-57		LINE PRIMER - From tee to left rear back of engine to tee at left rear side engine	1	
-55	10143-18		LINE - Primer, from tee at right rear side of engine to right rear cylinder	1	
-56	11987-61		LINE - Primer, from tee at right rear side of engine to right front cylinder	1	
-57	10143-91		LINE - Primer, from tee at left rear side of engine to left front cylinder	1	
-58	10143-95		LINE - Primer, from tee at left rear side of engine to left rear cylinder	1	
-59	90797-02		SLEEVE - Primer line attachment at left front cylinder	1	
-60	60756-02		SPACER - Fuel selector	1	

When ordering, always specify Part Number, Description, and Serial Number of Aircraft

PIPER PARTS CATALOG

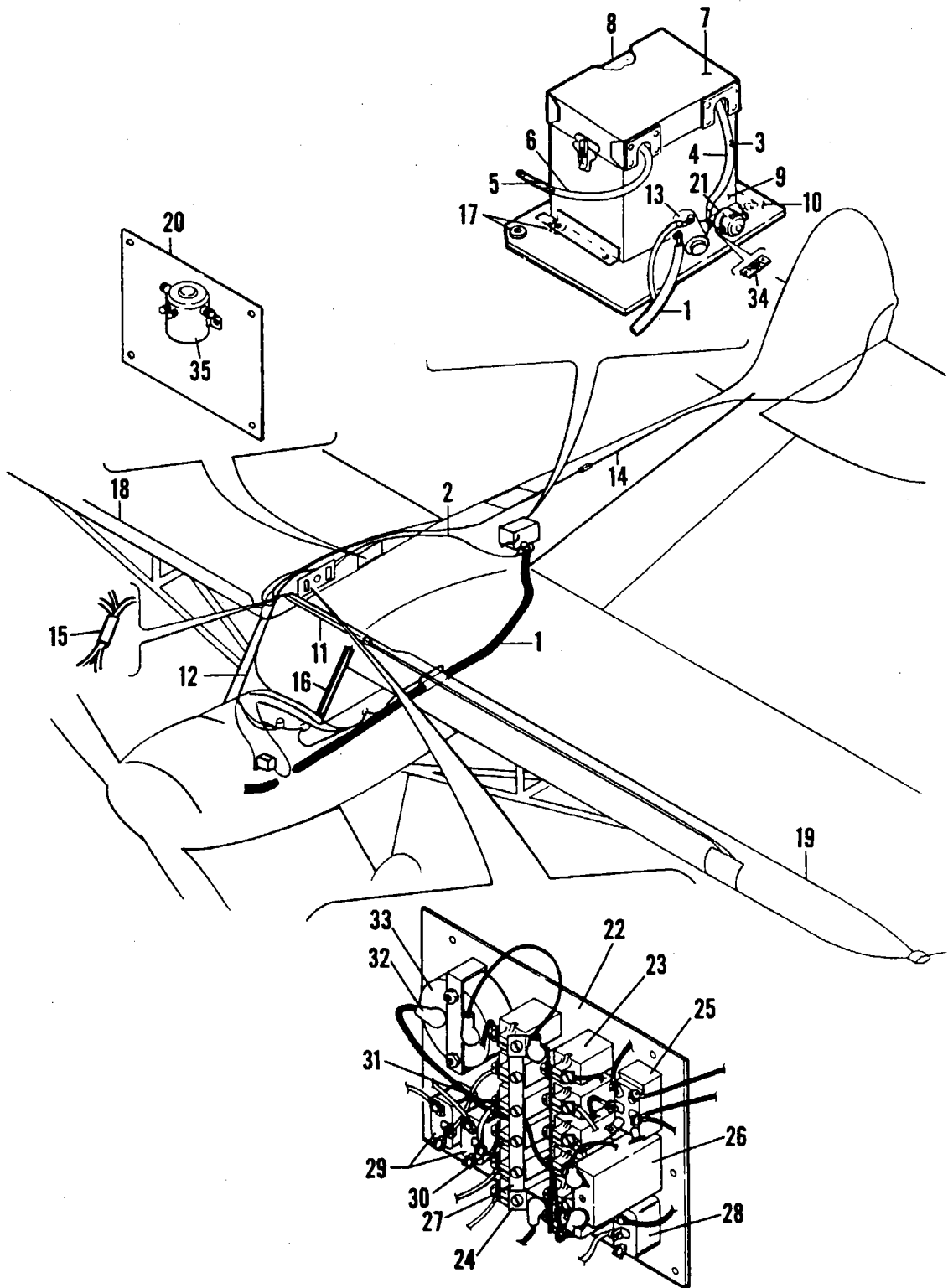

Figure 29 Electrical System Installation

---

# PIPER PARTS CATALOG

---

CODE EXPLANATIONS FOR FIGURE 29

PIPER PARTS CATALOG

Figure and Index Number	Part Number	Code	NOMENCLATURE	No. Req.	SERIAL NUMBERS AFFECTED
29-	15500		DRAWING - Electrical System Installation		
-1	14226-02		CABLE ASSEMBLY - Solenoid to starter	1	
-2	15503-02		HARNES ASSEMBLY - Battery to master switch panel	1	
-3	14224-12		CABLE ASSEMBLY - Battery to solenoid	1	
-4	189 080		* DUCT - Type S P 1/2" ID	6"	
-5	17604-30		CABLE ASSEMBLY - Battery ground	1	
-6	189 080		* DUCT - Type S P 1/2" ID	6½"	
-7	14065-00		COVER ASSEMBLY - Battery box	1	
-8	450 035		BATTERY - Reading (No R-35-12V)	1	
-9	14064-00		BOX ASSEMBLY - Battery	1	
-10	14890-03		BOARD ASSEMBLY - Battery box mounting	1	
-11	12298-11		HARNES ASSEMBLY - Wire, landing light switch to wing root	1	
-12	15504-02		HARNES ASSEMBLY - Wire (voltage regulator, starter switch and alternator)	1	
-13	487 149		SOLENOID - Starter	1	
-14	12177-28		WIRE ASSEMBLY - Tail light, disconnect to rudder	1	
-15	14510-00		HARNES ASSEMBLY - Navigation light in top deck	1	
-16	18576-06		STRIP - Insulator, inside right front windshield channel	1	
-17	80122-10		WASHER	8	
-18	10128-27		WIRE ASSEMBLY - Navigation light, RH	1	
-19	10128-28		WIRE ASSEMBLY - Navigation light, LH	1	
-20	15491-02		PLATE - Solenoid mounting	1	
-21	455 151		RELAY - Power (6041H105A)	1	
-22	89228-02		PANEL - Switch	1	
-23	454 738		CIRCUIT BREAKER - (PS50120-4-71) 5 amp	AR	
-24	84584-10		BUS BAR	2	
-25	487 793		SWITCH - Toggle, battery master	1	
-26	454 658		CIRCUIT BREAKER - (PS50120-5-3) 60 amp	1	
-27	84584-09		BUS BAR	2	
-28	487 791		SWITCH - Toggle, landing light	1	
-29	487 791		SWITCH - Toggle, navigation and anticollision light	2	
-30	454 638		CIRCUIT BREAKER - (PS50120-4-4) 20 amp	1	
-31	454 739		CIRCUIT BREAKER - (PS50120-4-72) 7 5 amp	1	
-32	23969-03		NIPPLE	6	
-33	66696-00		AMMETER	1	
-34	60766-02		CABLE ASSEMBLY	1	
-35	484 373		RELAY - Landing light (24059)	1	

When ordering, always specify Part Number, Description, and Serial Number of Aircraft

---

**PIPER PARTS CATALOG**

---

**THIS PAGE INTENTIONALLY LEFT BLANK**

PIPER PARTS CATALOG

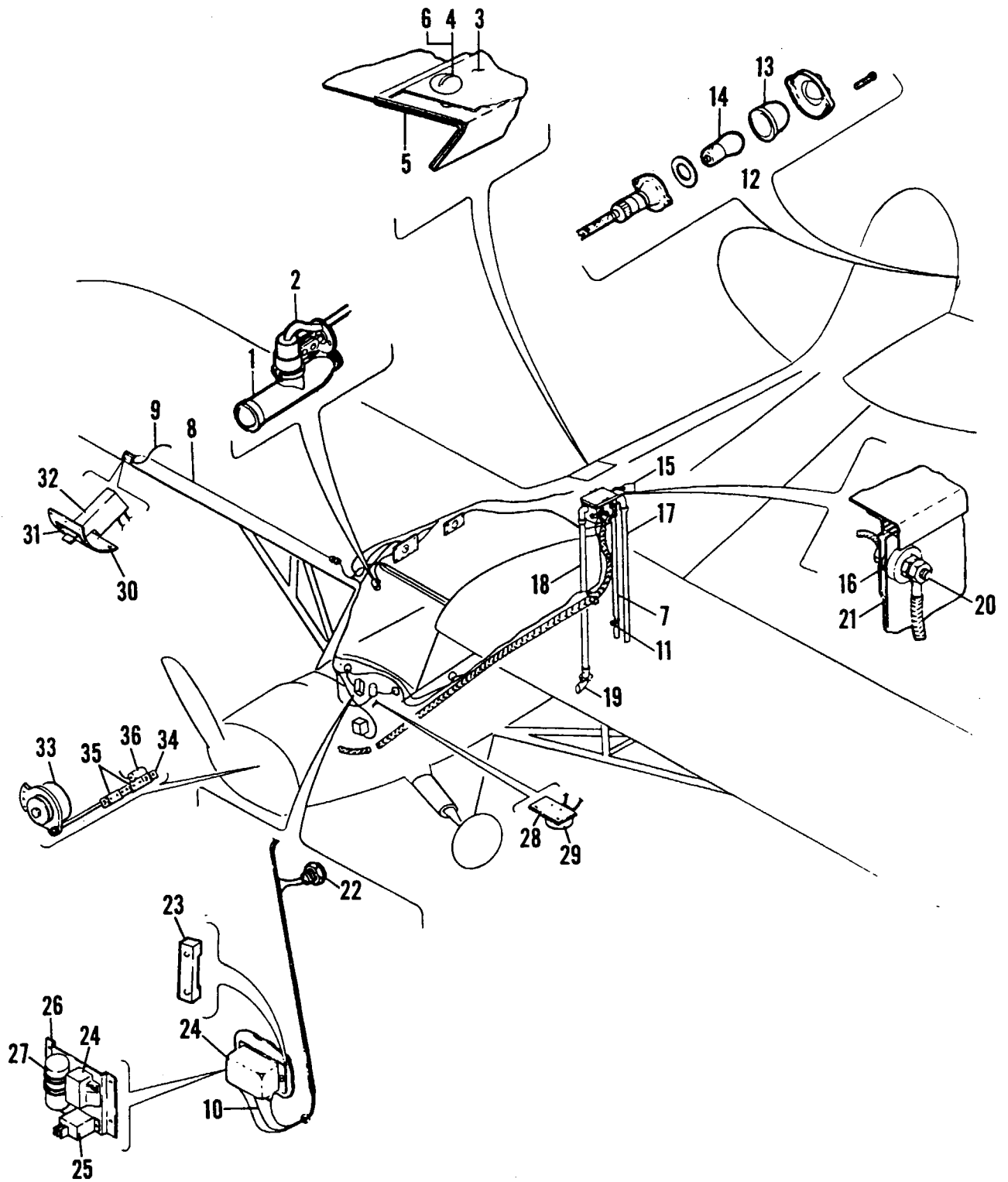

Figure 30 Electrical Components Installation



---

# PIPER PARTS CATALOG

---

CODE EXPLANATIONS FOR FIGURE 30

PIPER PARTS CATALOG

Figure and Index Number	Part Number	Code	NOMENCLATURE	No Req.	SERIAL NUMBERS AFFECTED
30-	15500		DRAWING - Electrical System Installation		
-1	472 660		LIGHT - Cockpit	1	
-2	90797-13		SLEEVE - Insulator	1	
-3	13180-00		DOOR ASSEMBLY - Battery access	1	
-4	487 563		* STUD - Fastener (No 5-0-140A)	4	
	463 368		* GROMMET - (No GOS-5-93)	4	
-5	13179-00		FRAME ASSEMBLY - Battery door	1	
-6	487 288		* SPRING - Fastener (No 5-295)	4	
-7	22369-04		TUBE - Battery drain	1	
-8	12177-68		WIRE ASSEMBLY - Wing unit	1	
-9	12177-69		WIRE ASSEMBLY - Ground	1	
-10	12177-22		WIRE ASSEMBLY - Voltage regulator to generator	1	
-11	454 925		CLAMP - Battery drain tube (No 18-882)	1	
-12	472 736		LIGHT - Navigation, tail (A2064-1073)	1	
-13	751 203		* LENS - White (No A2103-1)	1	
-14	753 341		* BULB - (10-73)	1	
-15	14072-00		TAG - Battery service instructions	1	
-16	81342-56		WASHER - Terminal bolt attachment	2	
-17	22369-23		TUBE - Battery vent, outlet	1	
-18	22369-23		TUBE - Battery vent, inlet	1	
-19	14066-00		TUBE ASSEMBLY - Battery air intake	1	
-20	14225-00		BOLT ASSEMBLY - Terminal	2	
-21	14070-00		STRIP - Insulation, positive terminal	1	
-22	487 550		SWITCH - Starter (CHC9011)	1	
-23	470 648		MOUNT ASSEMBLY - Voltage regulator shock	1	
-24	756 586		VOLTAGE REGULATOR - (60 amp alternator)	1	
-25	60727-03		RELAY ASSEMBLY - Overvoltage	1	
-26	60754-04		BRACKET ASSEMBLY - Voltage regulator mounting	1	
-27	762 256		SPIKE GUARD - Voltage (A-178)	1	
-28	44235-00		PLATE - Stall warning horn mounting	1	
-29	565 288		HORN - Stall warning (02054-3)	1	
-30	16860-00		PLATE ASSEMBLY - Lift detector reinforcement	1	
-31	19807-00		PLATE - Lift detector mounting	1	
-32	450 742		LIFT DETECTOR - (C-52207-4)	1	
-33	751 349		ALTERNATOR - (A-152A)	1	
-34	761 620		MOUNTING BAR - (A-167-9)	1	
-35	761 618		MOUNTING BRACKET - (A-167-10)	2	
-36	758 080		CAPACITOR - (A-177)	1	

When ordering, always specify Part Number, Description, and Serial Number of Aircraft

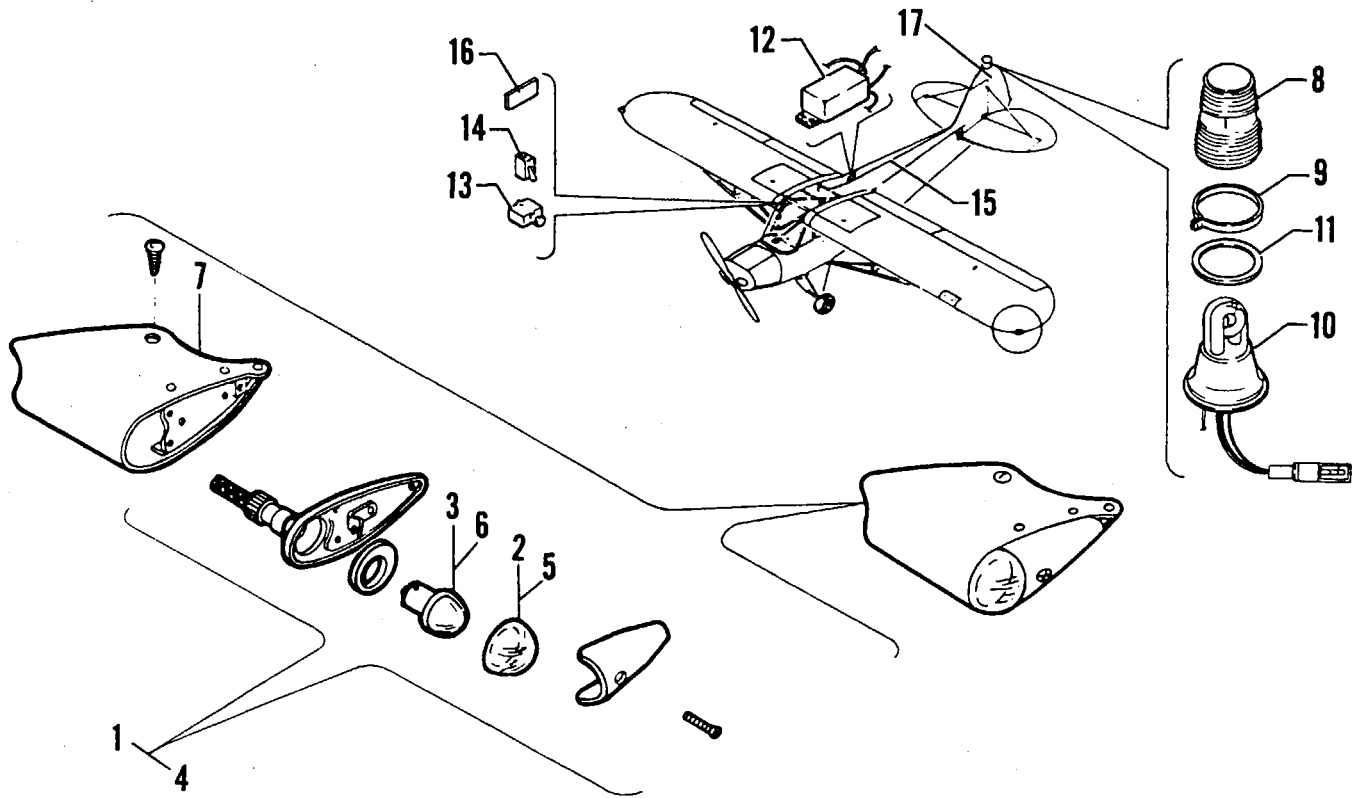

Figure 31 Wing Light and Strobe Light Installation

---

# PIPER PARTS CATALOG

CODE EXPLANATIONS FOR FIGURE 31

PIPER PARTS CATALOG

Figure and Index Number	Part Number	Code	NOMENCLATURE	No. Req.	SERIAL NUMBERS AFFECTED
31-1	472 665		LIGHT - Navigation, wing, red, LH (Grimes No A1285)	1	
-2	751 202		* LENS - Red (No A1280-2)	1	
-3	751 381		* BULB - (No 1512)	1	
-4	472 666		LIGHT - Navigation, wing, green, RH (Grimes No A1285)	1	
-5	751 201		* LENS - Green, (No A1280-3)	1	
-6	751 381		* BULB - No 1512	1	
-7	12560-00		BRACKET ASSEMBLY - Navigation light, wing	2	
-8	44291-02		LENS - Strobe light	1	
-9	755 200		CLAMP - Ring assembly (A409)	4	
-10	761 189		FLASH TUBE - (A469D)	1	
-11	755 042		GASKET - (A467)	1	
-12	757 359		POWER SUPPLY - (A412A-14) Single flash	1	
	472 963		POWER SUPPLY - (A412A-14DF) Double flash	1	
-13	454 738		CIRCUIT BREAKER (PS50120-4-71)	1	
-14	487 791		SWITCH - (110-S-73)	1	
-15	15857-02		CABLE ASSEMBLY - Tail strobe light	1	
-16	80380-02		PLACARD - Warning, anticollision light	1	
-17	14773-05		RUDDER ASSEMBLY	1	

When ordering, always specify Part Number, Description, and Serial Number of Aircraft

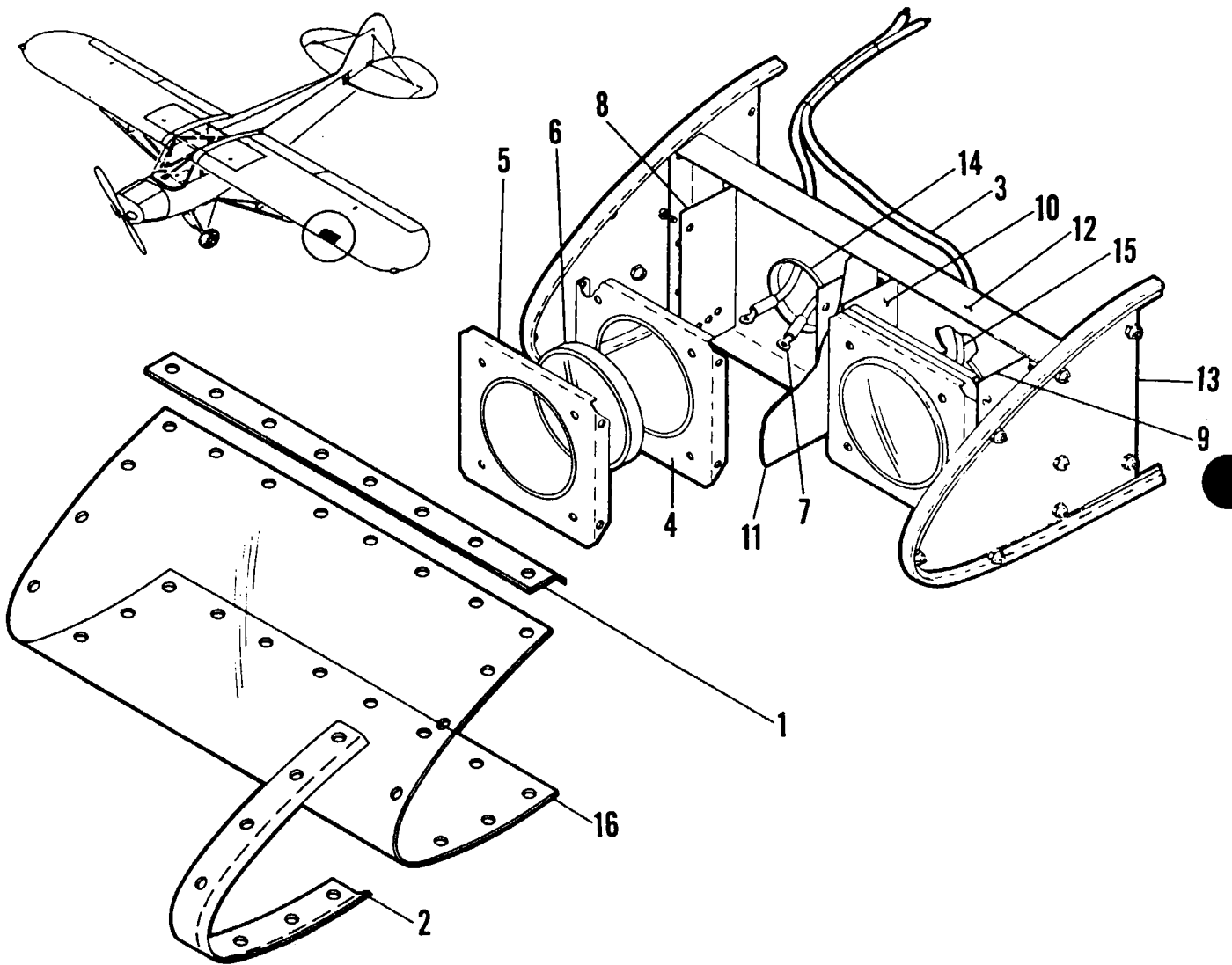

Figure 32 Landing Light Installation

---

# PIPER PARTS CATALOG

---

CODE EXPLANATIONS FOR FIGURE 32

PIPER PARTS CATALOG

Figure and Index Number	Part Number	Code	NOMENCLATURE	No. Req.	SERIAL NUMBERS AFFECTED
32-	14442 14502		DRAWING - Landing Light Installation DRAWING - Landing Light Assembly		
-1	14787-03		STRIP - Landing light window attachment, top and bottom	2	
-2	14786-00		STRIP - Side attachment, left	1	
	14786-01		STRIP - Side attachment, right	1	
-3	49977-86		HARNESS ASSEMBLY - Wire	1	
-4	12525-00		PLATE - Landing light attachment	2	
-5	12525-02		PLATE - Landing light attachment	2	
-6	472 661		LIGHT - Landing, 100W-12V (No 4509)	2	
-7	12177-33		WIRE ASSEMBLY - Light, ground, outboard	1	
-8	12524-03		BRACKET	1	
-9	12524-04		BRACKET	1	
-10	12524-02		BRACKET	1	
-11	12529-03		PLATE - Reinforcement	1	
-12	12527-03		PLATE - Landing light mounting	1	
-13	12529-02		PLATE - Reinforcement	1	
-14	189 625		GROMMET - (MS21266-1N) (12 75" Long)	AR	
-15	10128-93		WIRE ASSEMBLY - Light, ground, inboard	1	
-16	14785-03		WINDOW - Landing light	1	

When ordering, always specify Part Number, Description, and Serial Number of Aircraft



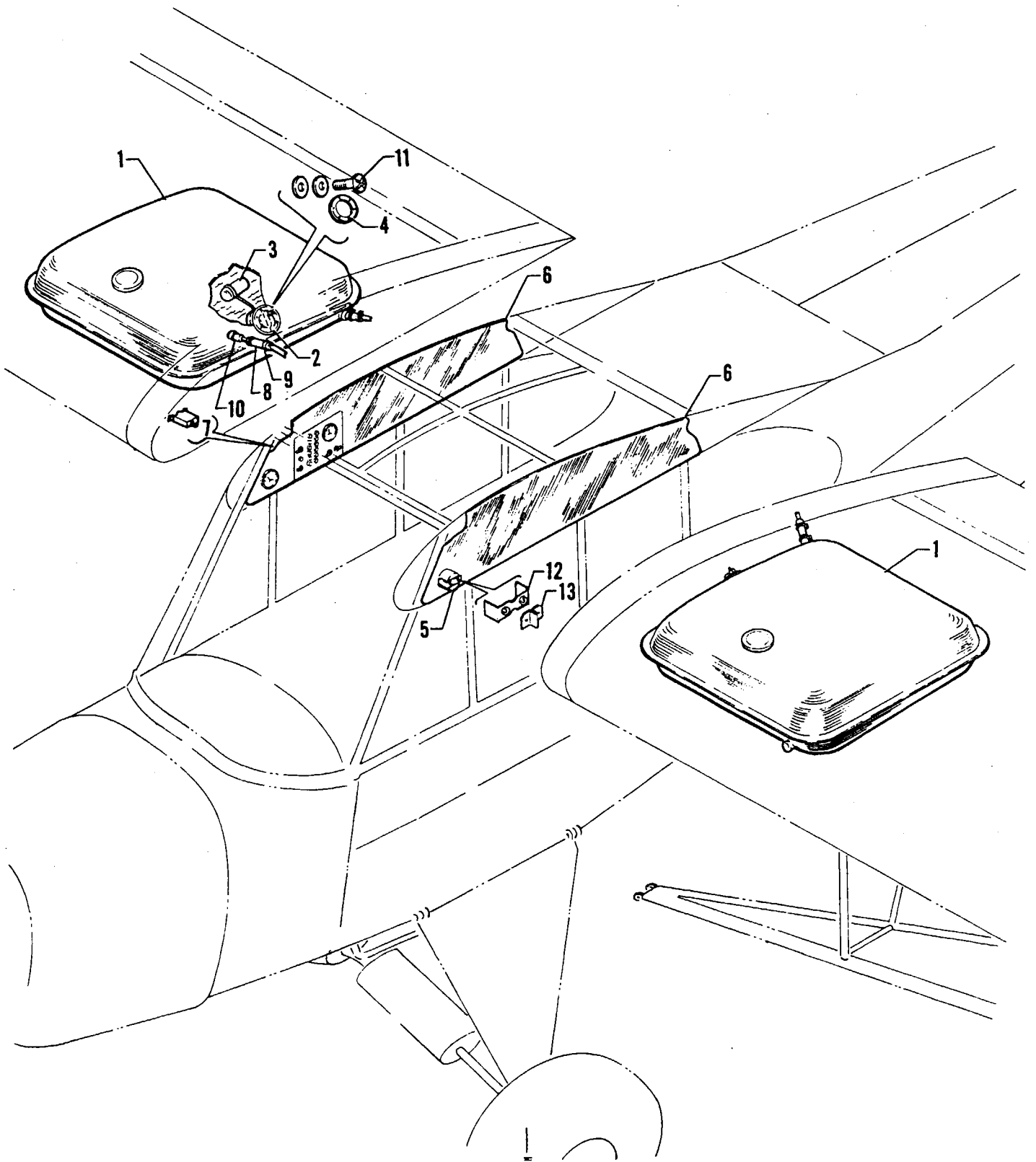

Figure 33 Electric Fuel Gauge Installation

---

# PIPER PARTS CATALOG

CODE EXPLANATIONS FOR FIGURE 33

**PIPER PARTS CATALOG**

Figure and Index Number	Part Number	Code	NOMENCLATURE	No. Req.	SERIAL NUMBERS AFFECTED
33-	15277		DRAWING - Electric Fuel Gauge Installation		
-1	18049-34		TANK ASSEMBLY - Fuel, left	1	
	18049-43		TANK ASSEMBLY - Fuel, right	1	
-2	60762-02		GAUGE ASSEMBLY - Fuel, tank unit (548 532)	2	
-3	751 767		* FLOAT ASSEMBLY - Fuel gauge	1	
-4	755 049		GASKET - Fuel tank unit (15-423)	2	
-5	15166-02		GAUGE ASSEMBLY - Fuel, panel unit	2	
-6	15271-08		PANEL - Cockpit, upper left trim	1	
	14337-05		PANEL - Cockpit, upper right trim	1	
-7	454 738		CIRCUIT BREAKER - (PS50120-4-71)	2	
-8	82371-06		HOSE - Vent line	1	
-9	454 983		CLAMP - Hose (8)	2	
-10	458 940		ELBOW - Fuel tank vent (AN844-4D)	1	
-11	48659-11		SCREW ASSEMBLY - Seal	10	
-12	487 726		STRAP - Mounting (A C 6460429)	2	
-13	487 350		SEPARATOR - Terminal (A C 1515642)	2	

When ordering, always specify Part Number, Description, and Serial Number of Aircraft

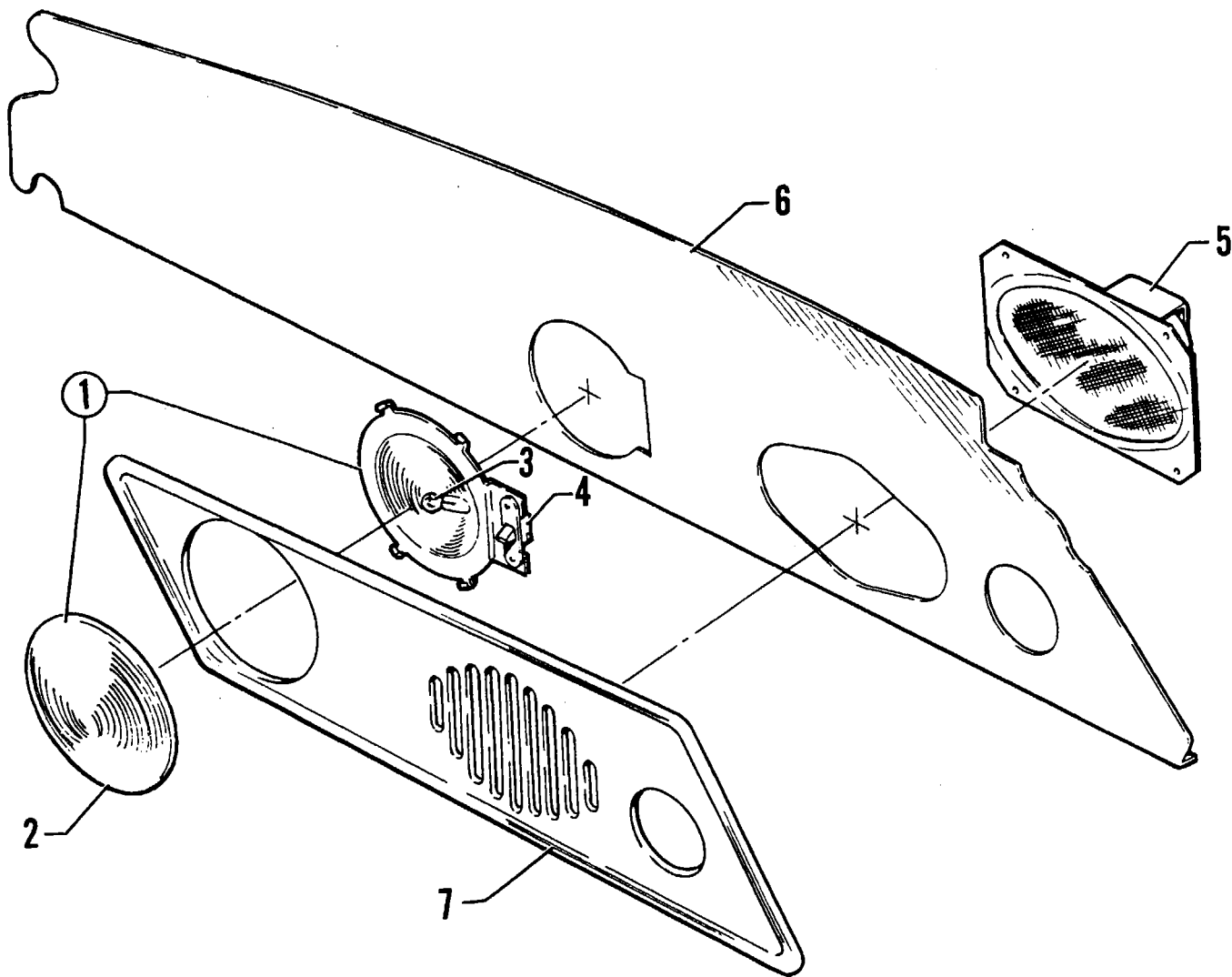

Figure 34 Speaker and Dome Light Installation

---

# PIPER PARTS CATALOG

---

CODE EXPLANATIONS FOR FIGURE 34

PIPER PARTS CATALOG

Figure and Index Number	Part Number	Code	NOMENCLATURE	No. Req.	SERIAL NUMBERS AFFECTED
34-	15285		DRAWING - Speaker and Dome Light Installation		
-1	15281-00		LIGHT ASSEMBLY - Dome	1	
-2	12715-00		* LENS - Dome light (PAC 472 330)	1	
-3	472 036		* BULB - Dome light (89)	1	
-4	487 777		SWITCH - Dome light (5518)	1	
-5	21879-02		SPEAKER ASSEMBLY	1	
-6	15271-08		PANEL - Cockpit, upper left trim	1	
-7	15318-00		PANEL - Speaker	1	

When ordering, always specify Part Number, Description, and Serial Number of Aircraft

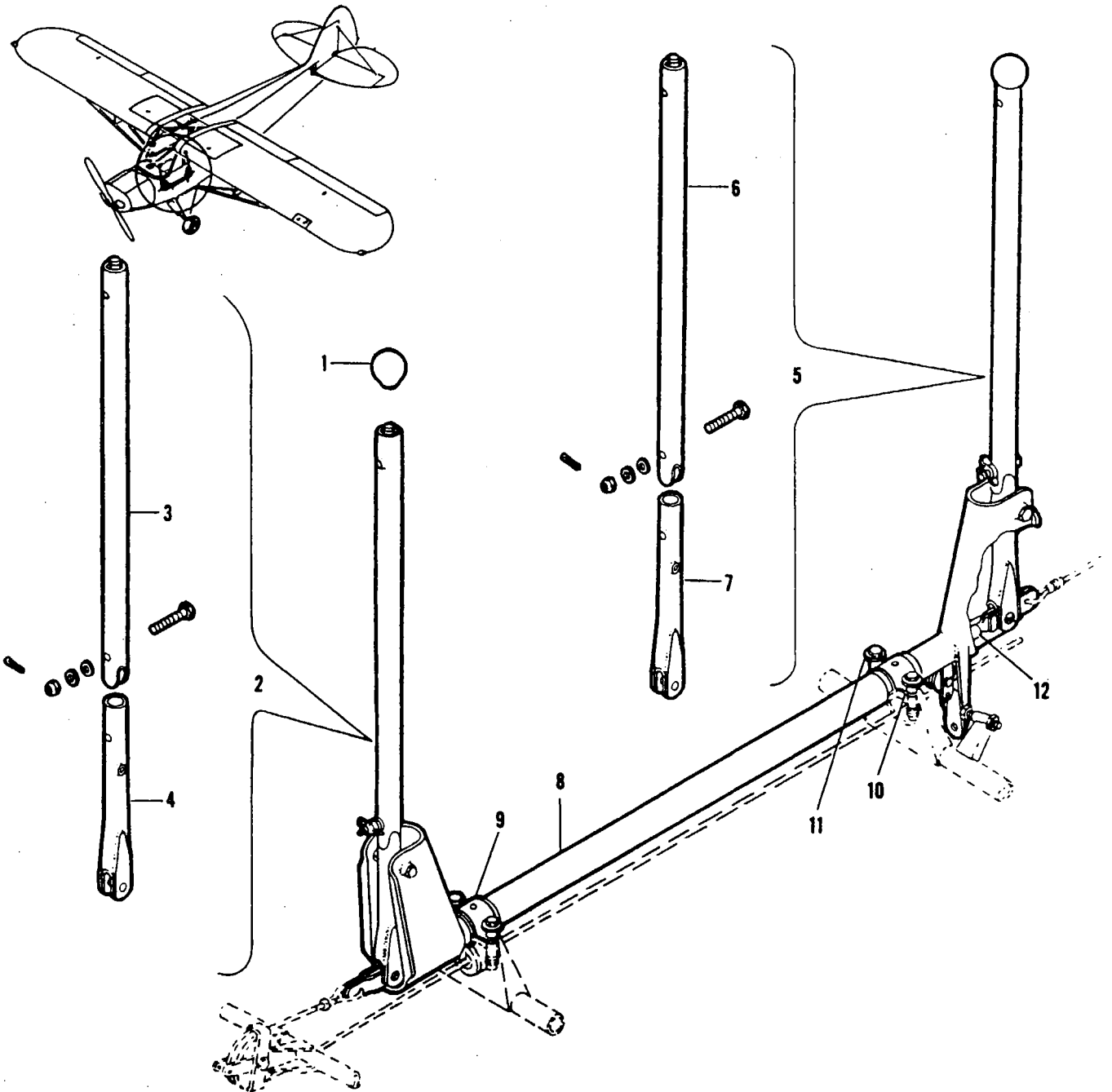

Figure 35 Elevator and Aileron Control Installation

---

# PIPER PARTS CATALOG

CODE EXPLANATIONS FOR FIGURE 35



PIPER PARTS CATALOG

Figure and Index Number	Part Number	Code	NOMENCLATURE	No. Req.	SERIAL NUMBERS AFFECTED
35-	13739		DRAWING - Control Installation, Elevator and Aileron (dual control)		
-1	18875-07		KNOB	2	
-2	13733-04		STICK ASSEMBLY - Front	1	
-3	13731-04		* STICK - Top	1	
-4	13729-00		* STUB ASSEMBLY	1	
-5	13733-04		STICK ASSEMBLY - Rear	1	
-6	13731-04		* STICK - Top	1	
-7	13729-00		* STUB ASSEMBLY	1	
-8	13735-00		TORQUE TUBE ASSEMBLY - Dual control	1	
-9	21811-03		CAP - Bearing	2	
-10	41371-02		SHIMS - Torque tube bearing attachment	AR	
	41371-03		SHIMS - Torque tube bearing attachment	AR	
	41371-04		SHIMS - Torque tube bearing attachment	AR	
-11	80122-17		WASHER - Torque tube bearing attachment	4	
-12	40261-00		TUBE ASSEMBLY - Control stick connector (with dual control)	1	

When ordering, always specify Part Number, Description, and Serial Number of Aircraft



---

# PIPER PARTS CATALOG

---

CODE EXPLANATIONS FOR FIGURE 36

PIPER PARTS CATALOG

Figure and Index Number	Part Number	Code	NOMENCLATURE	No. Req.	SERIAL NUMBERS AFFECTED
36-1	40123-78		CABLE ASSEMBLY - Bungee	1	
	40123-89		CABLE ASSEMBLY - Bungee	1	
-2	13745-00		CABLE ASSEMBLY - Elevator, lower	1	
-3	42722-02		* TURNBUCKLE ASSEMBLY - Control cable	1	
-4	41271-02		LINK - Cable attachment	1	
-5	10870-16		CABLE ASSEMBLY - Elevator, upper	1	
-6	42722-02		* TURNBUCKLE ASSEMBLY - Control cable	1	
-7	80421-00		PULLEY - Fibre 1-3/4"	4	
-8	81342-42		WASHER	6	
-9	86102-92		BUSHING	2	
-10	12241-00		BRACKET - Pulley guard	2	
-11	41001-00		PULLEY - 2-3/4"	1	
-12	80122-18		WASHER	2	
-13	11200-00		PULLEY	1	
-14	80012-04		BUSHING - Insert	1	
-15	40071-00		FAIRLEAD - Cable	2	
-16	40081-00		RING - Snap	1	

When ordering, always specify Part Number, Description, and Serial Number of Aircraft

PIPER PARTS CATALOG

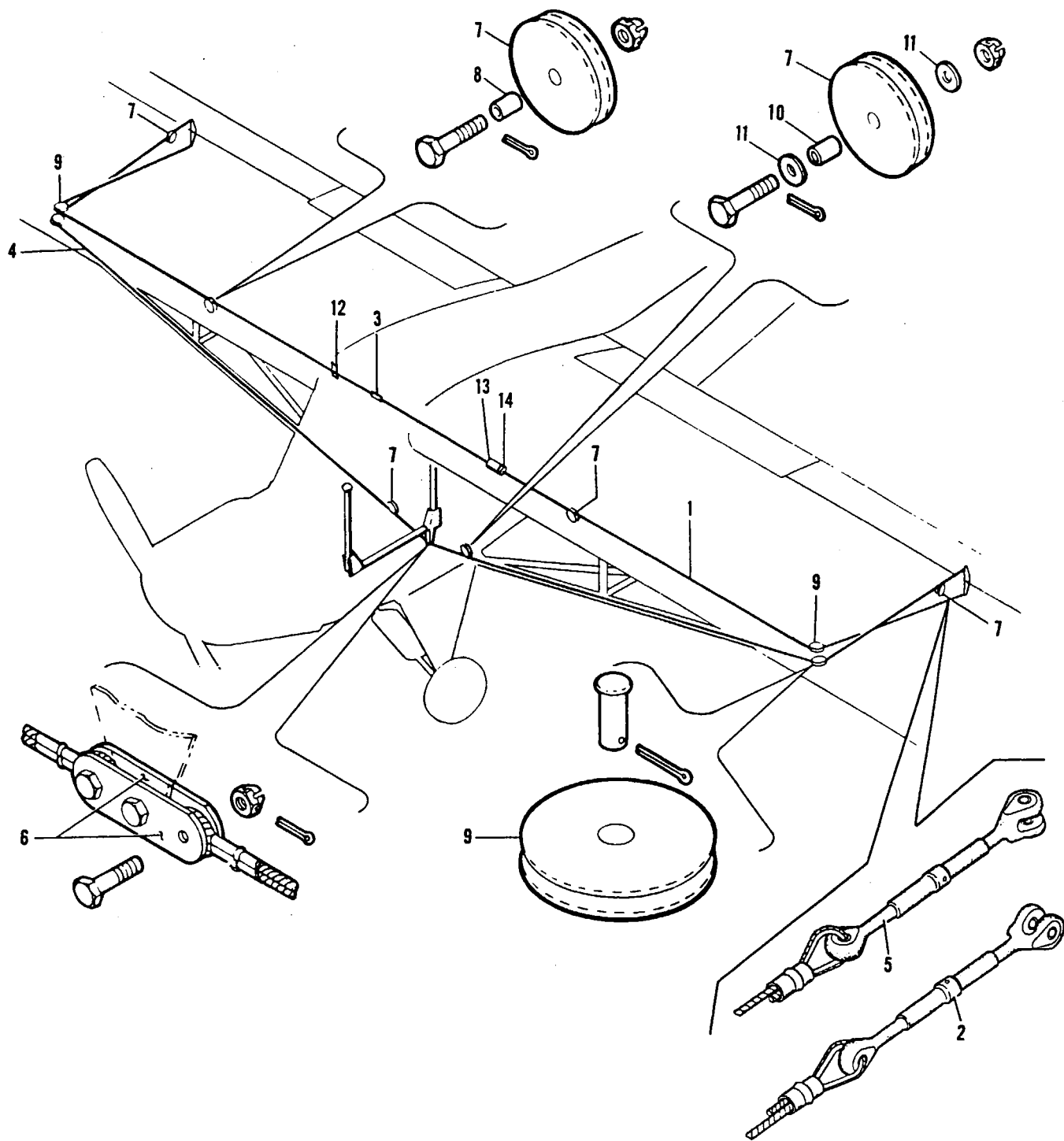

Figure 37 Aileron Control System

---

# PIPER PARTS CATALOG

CODE EXPLANATIONS FOR FIGURE 37

PIPER PARTS CATALOG

Figure and Index Number	Part Number	Code	NOMENCLATURE	No. Req.	SERIAL NUMBERS AFFECTED
37-1	14300-19		CABLE ASSEMBLY - Aileron control, balance	2	
-2	42722-02		* TURNBUCKLE ASSEMBLY - Control cable	1	
-3	81262-36		LINK	2	
-4	14300-28		CABLE ASSEMBLY - Aileron control, torque tube to aileron	2	
-5	42722-02		* TURNBUCKLE ASSEMBLY - Control cable	1	
-6	81352-32		LINK - Connecting, aileron cable (2 312 L )	1	
-7	80421-00		PULLEY - Fibre, 1-3/4"	6	
-8	80012-03		BUSHING	4	
-9	40991-00		PULLEY	4	
-10	80012-04		BUSHING	2	
-11	81342-42		WASHER - Spacer	4	
-12	40731-00		PLATE - Rub, cable	3	
-13	40701-00		FAIRLEAD - Cable	8	
-14	40081-00		RING - Snap, fairlead	4	

When ordering, always specify Part Number, Description, and Serial Number of Aircraft

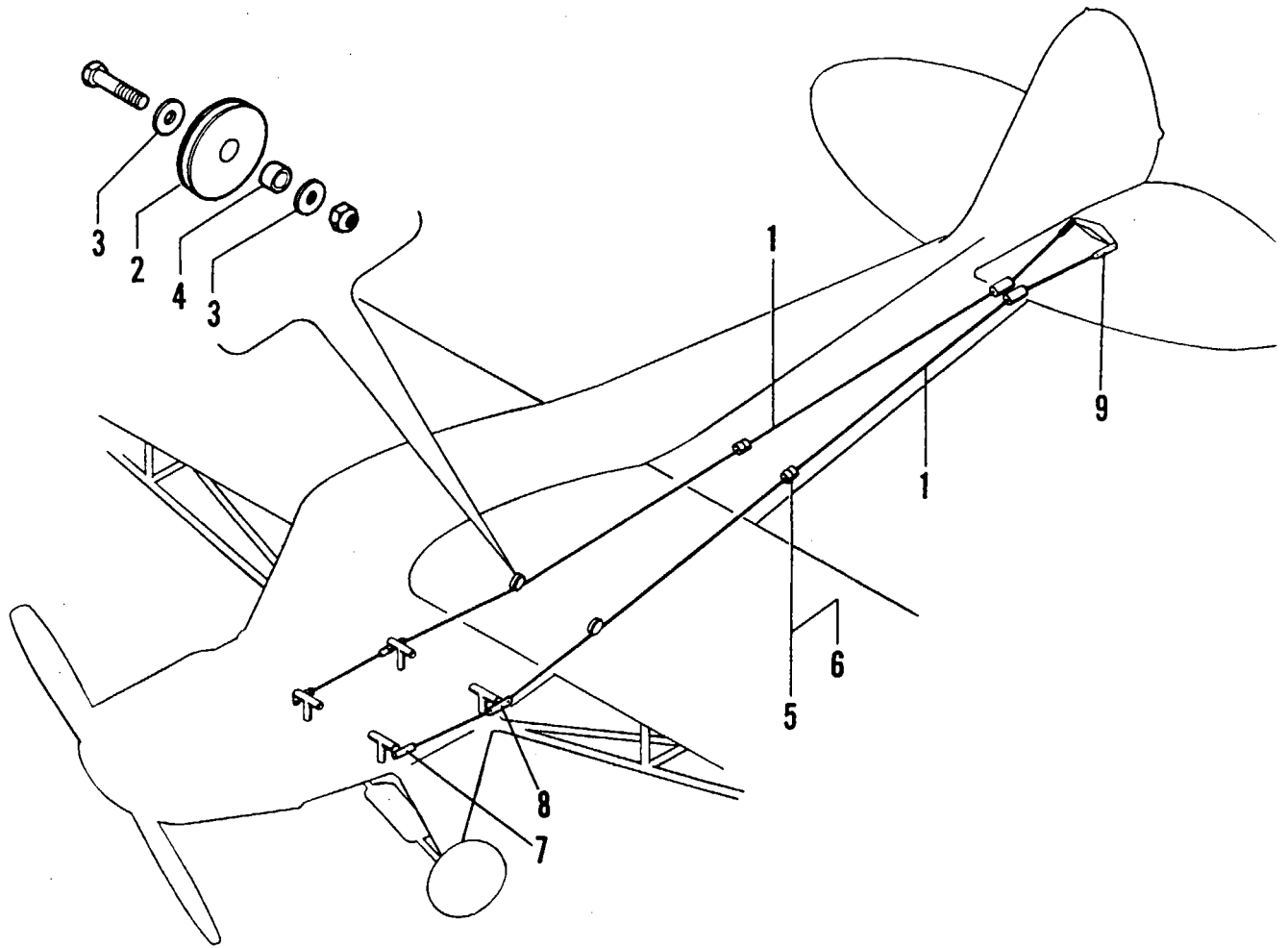

Figure 38 Rudder Control System



---

# PIPER PARTS CATALOG

---

CODE EXPLANATIONS FOR FIGURE 38

### PIPER PARTS CATALOG

Figure and Index Number	Part Number	Code	NOMENCLATURE	No. Req.	SERIAL NUMBERS AFFECTED
38-1	10865-05		CABLE ASSEMBLY - Rudder	2	
-2	80421-00		PULLEY	2	
-3	80122-18		WASHER	4	
-4	80012-04		BUSHING - Insert	2	
-5	40071-00		FAIRLEAD - Cable, segment	8	
-6	40081-00		RING - Snap	4	
-7	10866-00		FITTING ASSEMBLY - Rudder cable, front	2	
-8	10867-00		FITTING ASSEMBLY - Rudder cable, center	2	
-9	10868-00		FITTING ASSEMBLY - Rudder cable, rear	2	

When ordering, always specify Part Number, Description, and Serial Number of Aircraft



---

# PIPER PARTS CATALOG

CODE EXPLANATIONS FOR FIGURE 39

PIPER PARTS CATALOG

Figure and Index Number	Part Number	Code	NOMENCLATURE	No. Req.	SERIAL NUMBERS AFFECTED
39-1	12794-04		CABLE ASSEMBLY - Flap control, in fuselage	1	
-2	14300-27		CABLE ASSEMBLY - Flap control, upper	1	
-3	42722-02		* TURNBUCKLE ASSEMBLY - Control cable	1	
-4	487 328		SPRING - Flap return (14384-00)	2	
-5	81262-14		LINK - Cable to bellcrank	4	
-6	41001-00		PULLEY	5	
-7	81342-11		WASHER	5	

When ordering, always specify Part Number, Description, and Serial Number of Aircraft

---

**PIPER PARTS CATALOG**

**THIS PAGE INTENTIONALLY LEFT BLANK**

PIPER PARTS CATALOG

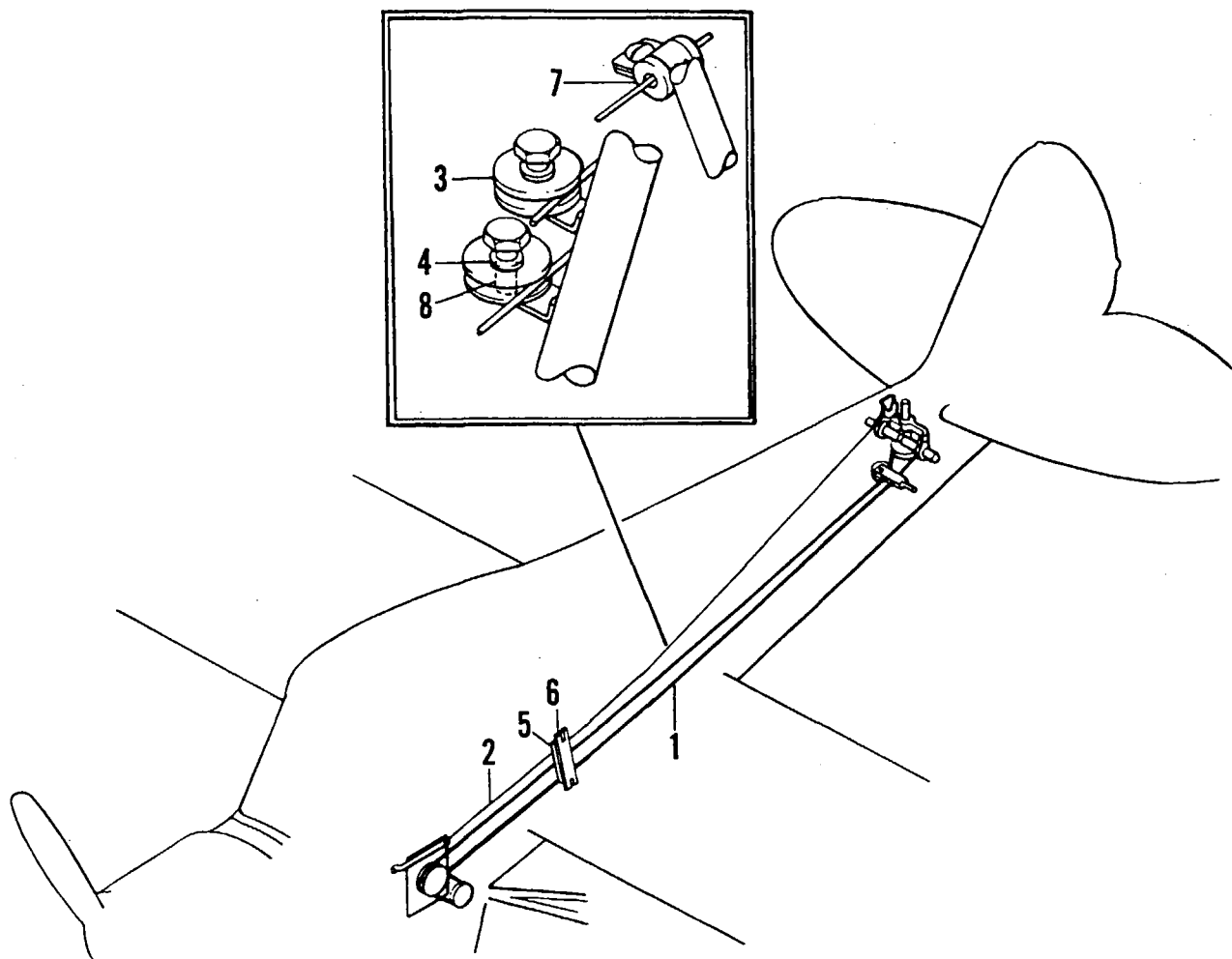

Figure 40 Adjustment Stabilizer Control System

---

# PIPER PARTS CATALOG

CODE EXPLANATIONS FOR FIGURE 40



**PIPER PARTS CATALOG**

Figure and Index Number	Part Number	Code	NOMENCLATURE	No. Req.	SERIAL NUMBERS AFFECTED
40-	14486		DRAWING - Stabilizer Adjustment Cable Installation		
-1	41671-17		CABLE - Stabilizer adjustment	1	
	41671-19		CABLE - Stabilizer adjustment	1	
-2	42664-03		WIRE - Stabilizer indicator	1	
-3	43001-00		PULLEY - Stabilizer adjustment control cable, 1 inch	2	
-4	80122-18		WASHER - Stabilizer adjustment pulley	4	
-5	40721-00		BLOCK - Rubbing, stabilizer control cable, front	1	
-6	40731-00		PLATE - Rub	1	
-7	42911-00		FAIRLEAD - Stabilizer indicator wire	1	
-8	80012-04		BUSHING - Insert	2	

When ordering, always specify Part Number, Description, and Serial Number of Aircraft

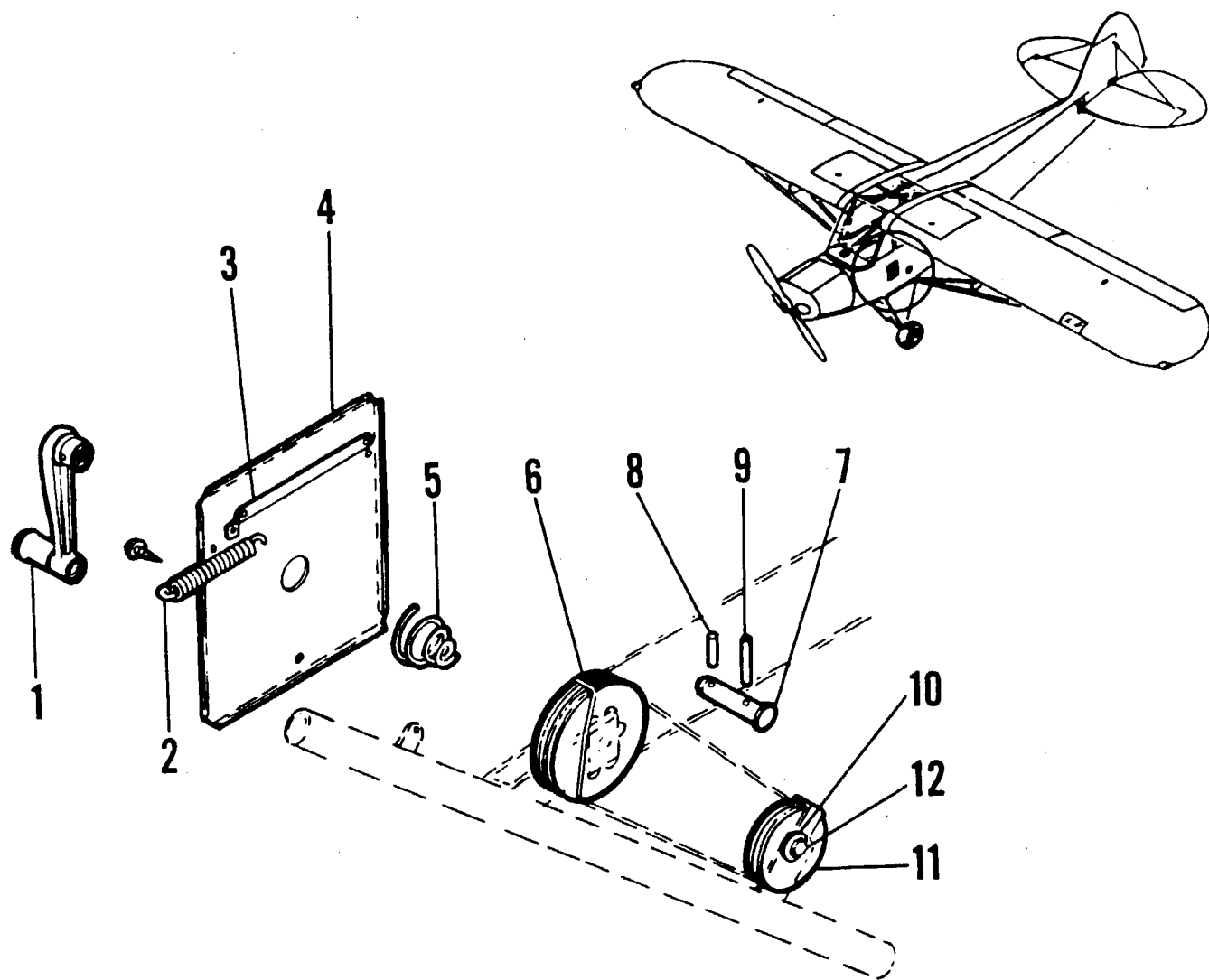

Figure 41 Stabilizer Adjustment Crank Installation

---

# PIPER PARTS CATALOG

---

CODE EXPLANATIONS FOR FIGURE 41

PIPER PARTS CATALOG

Figure and Index Number	Part Number	Code	NOMENCLATURE	No. Req.	SERIAL NUMBERS AFFECTED
41-	12999		DRAWING - Stabilizer Adjustment Crank Mechanism Installation		
-1	60291-02		CRANK ASSEMBLY - Stabilizer adjustment	1	
-2	42891-00		SPRING - Stabilizer indicator return	1	
-3	41121-00		INDICATOR ASSEMBLY	1	
-4	10936-00		PLATE - Indicator cover	1	
-5	41151-00		SPRING - Stabilizer crank	1	
-6	12983-00		PULLEY	1	
-7	12105-00		PIN - Crankshaft	1	
-8	480 731		PIN - (59-028-125-0750)	1	
-9	81761-04		PIN - Crank pulley locking	1	
-10	80122-18		WASHER - Spacer	2	
-11	80421-00		PULLEY	1	
-12	80012-04		BUSHING - Insert	1	

When ordering, always specify Part Number, Description, and Serial Number of Aircraft

# PIPER PARTS CATALOG

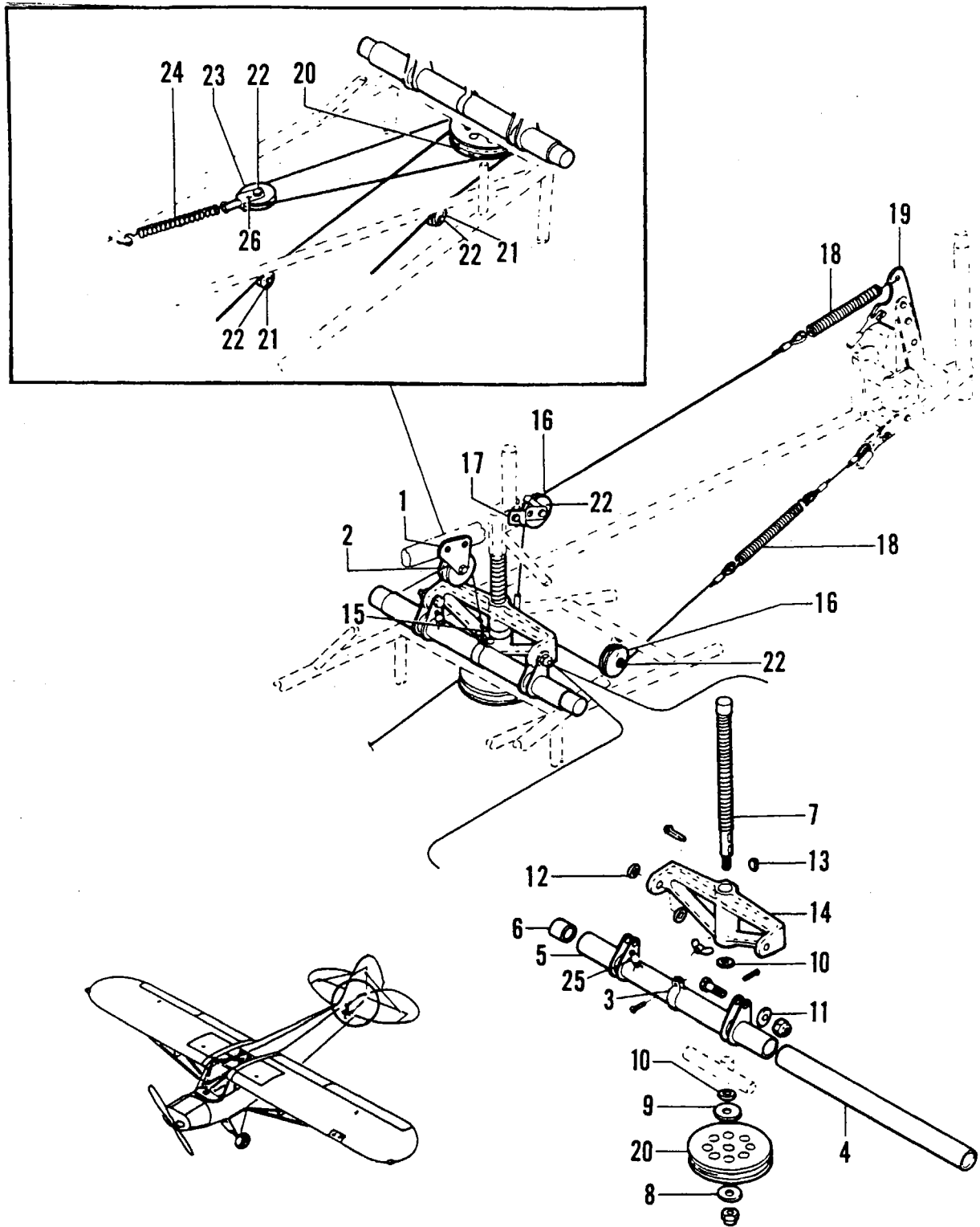

Figure 42. Stabilizer Adjustment Yoke and Bungee Installation

---

# PIPER PARTS CATALOG

CODE EXPLANATIONS FOR FIGURE 42

PIPER PARTS CATALOG

Figure and Index Number	Part Number	Code	NOMENCLATURE	No. Req	SERIAL NUMBERS AFFECTED
42-	13000 12263		DRAWING - Stabilizer Adjustment Mechanism Installation DRAWING - Bungee Installation		
-1	40821-03		FITTING - Pulley	2	
-2	80421-00		PULLEY	1	
-3	10466-28		CLAMP	1	
-4	86062-80		TUBE - Liner	1	
-5	14180-02		LINK ASSEMBLY	1	
-6	14177-00		* BUSHING - Insert, brass	2	
-7	42961-02		SCREW - Stabilizer adjustment	1	
-8	80122-41		WASHER	1	
-9	81342-05		WASHER	1	
-10	85012-12		WASHER	2	
-11	80122-24		WASHER	2	
-12	81342-08		WASHER	4	
-13	41631-00		KEY	1	
-14	42692-00		YOKE ASSEMBLY - Stabilizer adjustment	1	
-15	85211-00		CLAMP	1	
-16	80421-00		PULLEY	2	
-17	81381-00		HOUSING ASSEMBLY - Bungee pulley	1	
-18	10940-02		SPRING - Cable attachments	2	
-19	10449-00		LINK - Upper horn	1	
-20	12982-00		PULLEY	1	
-21	43001-00		PULLEY	2	
-22	80122-18		WASHER	6	
	80012-04		BUSHING - Insert	5	
-23	80421-00		PULLEY	1	
-24	81411-02		SPRING - Tension	1	
-25	460 693		FITTING - Grease (No 1688)	1	
-26	11692-05		BRACKET - Pulley	1	

When ordering, always specify Part Number, Description, and Serial Number of Aircraft

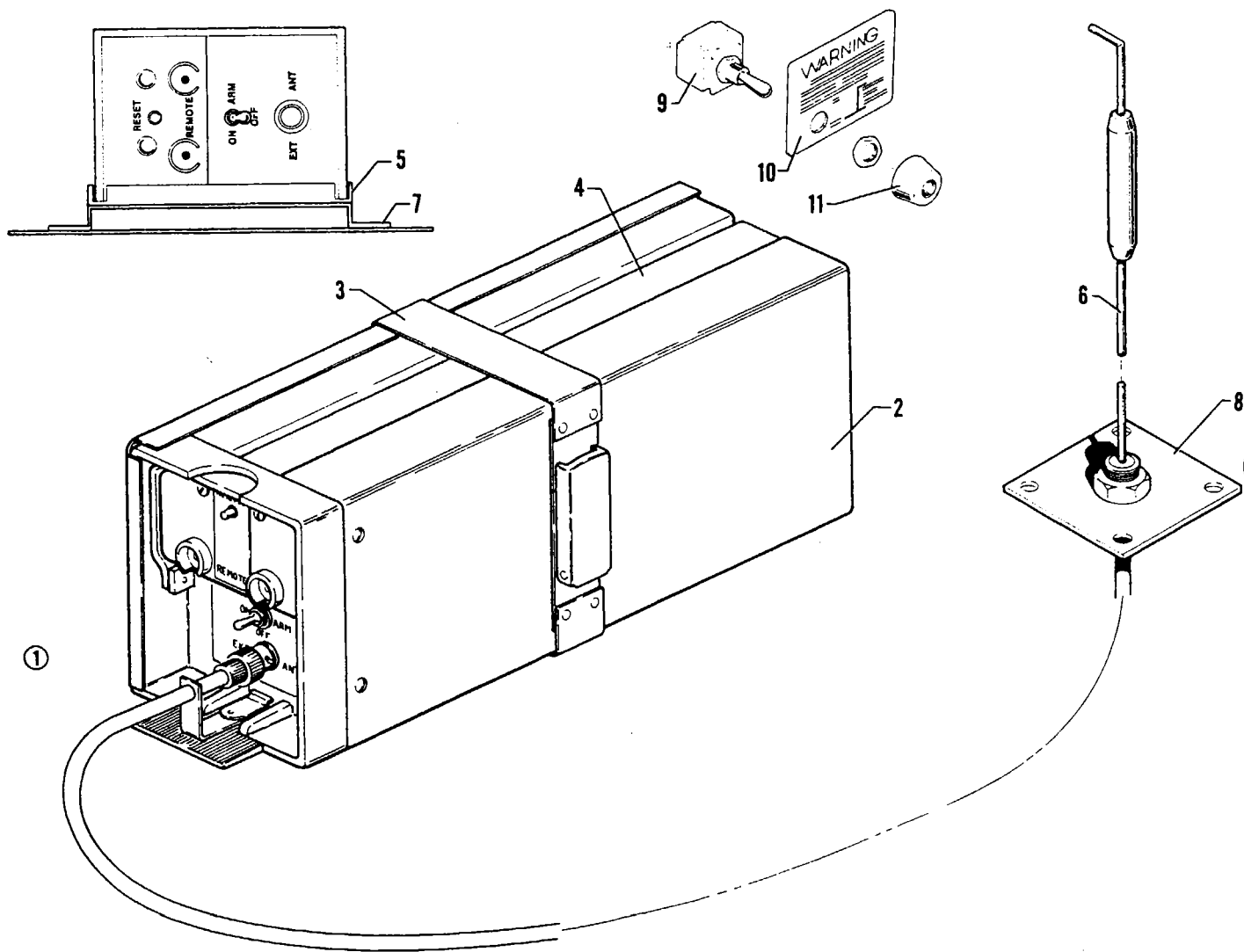

Figure 43 Piper Automatic Locator (ELT) Installation (Narco Avionics)



---

# PIPER PARTS CATALOG

---

CODE EXPLANATIONS FOR FIGURE 43

## PIPER PARTS CATALOG

Figure and Index Number	Part Number	Code	NOMENCLATURE	No. Req.	SERIAL NUMBERS AFFECTED
43-	66081		DRAWING - Piper Automatic Locator (ELT) Installation		
-1	54800-54		TRANSMITTER ASSEMBLY - Automatic locator (ELT 10) (includes alkaline battery pack)	1	
-2	758 452		* BATTERY PACK - Transmitter assembly (57674-00)	1	
-3	762 357		* STRAP - Transmitter assembly (57682-0101)	1	
-4	763 019		* ANTENNA - Blade, portable (57667-0001)	1	
-5	758 453		* BASE - Transmitter assembly (57666-0101)	1	
-6	597 257		ANTENNA ASSEMBLY - ELT (01652-0101)	1	
-7	39273-03		BRACKET ASSEMBLY - ELT mounting	1	
-8	60704-02		PLATE - Ground	1	
-9	587 965		SWITCH - (7101-K)	1	
-10	80687-02		PLACARD - Warning, ELT	1	
-11	477 829		NUT - Dress (8025)	1	

When ordering, always specify Part Number, Description, and Serial Number of Aircraft

---

# PIPER PARTS CATALOG

---

## CODE EXPLANATIONS FOR OPTIONAL EQUIPMENT

- A - Refer to figure 16 for a list of optional flight instruments
- B - Refer to figure 27 for vacuum system installation details

**PIPER PARTS CATALOG**

Figure and Index Number	Part Number	Code	NOMENCLATURE	No. Req.	SERIAL NUMBERS AFFECTED
	60717-02 765 371 44296-17	A B A A A	Vacuum instruments package Vacuum system (without vacuum instruments) Turn and slip indicator (electric) Vertical speed indicator Clock (electric) Outside air temperature gauge Night lighting package Strobe light kit assembly		

When ordering, always specify Part Number, Description, and Serial Number of Aircraft

# NUMERICAL INDEX

Part Number	Figure and Index No.
06161-02	15-1
06161-02	16-1
10016-17	2-22
10016-20	2-20
10016-21	2-21
10032-07	18-20
10032-08	18-20
10033-05	18-22
10033-06	18-22
10034-00	18-24
10049-02	10-10
10058-00	11-54
10061-00	11-46
10112-07	5-34
10128-27	29-18
10128-28	29-19
10128-93	32-15
10134-00	11-7
10143-18	28-55
10143-63	28-17
10143-91	28-57
10143-95	28-58
10143-97	28-17
10151-00	5-53
10161-04	5-19
10161-04	5-25
10161-05	5-32
10171-04	5-11
10171-04	5-14
10171-05	5-38
10175-00	26-9
10201-00	5-16
10201-00	5-21
10201-00	5-27
10201-00	5-30
10201-00	5-40
10221-00	5-15
10221-00	5-20
10221-00	5-26
10221-00	5-31
10221-00	5-39
10291-00	4-36
10292-00	9-23
10300-02	11-65
10401-00	4-17
10415-03	26-12
10449-00	42-19
10466-09	11-6

Part Number	Figure and Index No.
10466-21	23-15
10466-28	42-3
10466-33	23-16
10525-14	23-82
10525-18	23-19
10525-18	23-21
10525-19	23-83
10525-32	23-18
10531-04	5-51
10531-05	5-51
10545-00	9-47
10552-00	8-10
10552-01	8-10
10555-02	17-1
10556-02	17-16
10565-00	11-29
10630-05	4-3
10630-08	4-4
10641-00	4-23
10644-00	5-49
10648-03	4-20
10649-03	4-22
10650-02	4-21
10654-02	8-5
10656-00	8-6
10666-06	14-7
10668-00	10-14
10703-00	4-42
10703-03	4-32
10703-04	4-31
10705-00	5-12
10706-00	5-23
10707-00	5-28
10709-00	5-36
10711-00	6-17
10729-03	28-38
10734-00	22-25
10734-01	22-25
10748-00	18-25
10763-46	12-8
10776-02	9-51
10780-00	14-5
10799-00	13-1
10818-00	11-22
10849-34	2-26
10849-43	2-26
10865-05	38-1
10866-00	38-7

Part Number	Figure and Index No.
10867-00	38-8
10868-00	38-9
10870-16	36-5
10921-00	4-33
10921-00	4-43
10930-00	10-17
10933-00	9-15
10933-01	9-15
10934-00	9-16
10936-00	41-4
10940-02	42-18
10940-02	48-25
10984-00	9-22
10999-03	21-8
10999-05	21-7
11015-00	15-11
11015-00	16-18
11061-00	5-50
11151-02	5-77
11200-00	36-13
11207-03	11-49
11253-00	2-44
11299-02	28-13
11299-03	28-14
11300-03	28-4
11339-10	15-5
11339-10	16-7
11382-04	15-13
11382-04	16-20
11408-12	11-55
11408-13	11-57
11408-14	11-56
11420-03	12-26
11420-03	12-29
11432-09	9-45
11432-10	9-42
11432-11	9-38
11473-47	3-12
11523-00	2-3
11546-02	11-67
11580-00	5-48
11648-02	9-40
11648-02	9-44
11670-06	5-2
11670-07	5-2
11672-00	4-28
11675-02	4-29
11675-03	4-30

Part Number	Figure and Index No.
11677-00	4-25
11678-00	4-35
11682-00	2-12
11682-00	6-7
11692-00	11-28
11692-02	11-15
11692-02	11-42
11692-05	42-26
11699-06	12-17
11700-00	12-18
11719-00	2-6
11719-01	2-6
11723-00	12-20
11821-00	11-25
11821-01	11-25
11829-03	11-27
11987-15	28-11
11987-23	28-12
11987-57	28-54
11987-61	28-56
11994-22	9-60
12028-00	4-66
12036-02	10-16
12036-03	10-15
12079-00	12-11
12105-00	41-7
12177-22	30-10
12177-28	29-14
12177-33	32-7
12177-39	17-45
12177-39	17-45a
12177-68	30-8
12177-69	30-9
12178-02	11-21
12178-03	11-20
12179-00	11-4
12180-00	11-48
12184-02	11-30
12184-03	11-30
12193-08	9-36
12193-09	9-37
12193-10	9-35
12200-00	11-62
12202-00	11-62
12203-00	11-66
12205-02	11-58
12205-03	11-61
12205-04	11-60

# PIPER PARTS CATALOG

Part Number	Figure and Index No
12205-05	11-59
12205-06	11-45
12206-00	11-47
12213-00	23-75
12241-00	36-10
12244-00	12-27
12252-02	5-5
12252-03	5-6
12252-05	5-55
12252-06	5-7
12254-00	9-39
12254-03	9-41
12255-00	9-43
12256-10	10-8
12257-12	10-3
12259-00	9-46
12260-00	9-56
12261-00	9-56
12264-00	9-57
12264-01	9-57
12265-00	10-30
12267-16	12-23
12268-18	12-10
12269-00	12-12
12274-00	2-4
12274-02	2-4
12275-00	2-5
12275-01	2-5
12276-00	2-1
12276-01	2-1
12279-00	10-11
12284-02	10-25
12289-39	12-9
12293-48	12-7
12294-28	12-6
12298-11	29-11
12308-05	9-52
12309-00	9-54
12311-00	10-18
12314-00	9-71
12331-02	5-78
12345-04	8-11
12350-00	23-81
12351-15	23-66
12353-00	23-41
12356-03	25-1
12360-00	25-9
12362-03	25-5
12364-03	25-27
12364-05	25-27
12377-00	9-9
12378-00	9-10
12379-00	9-8
12379-02	9-7
12407-00	23-79
12408-00	23-78
12409-00	23-74
12410-00	23-73

Part Number	Figure and Index No
12411-02	23-72
12414-00	23-38
12430-00	9-66
12433-14	23-25
12436-10	23-26
12440-00	23-42
12444-00	9-53
12445-00	10-19
12446-08	11-63
12448-07	9-34
12457-12	23-22
12457-13	23-23
12524-02	32-10
12524-03	32-8
12524-04	32-9
12525-00	32-4
12525-02	32-5
12527-03	32-12
12529-02	32-13
12529-03	32-11
12532-03	2-37
12560-00	31-7
12567-04	21-43
12570-09	2-19
12571-02	8-1
12571-03	8-2
12573-02	17-42
12581-00	5-45
12591-02	8-4
12694-03	14-14
12707-00	25-14
12715-00	34-2
12723-04	25-8
12761-02	3-2
12761-02	9-2
12764-00	28-29
12767-00	11-24
12767-01	11-24
12769-00	17-35
12770-00	17-23
12774-00	12-16
12776-00	12-21
12777-00	11-8
12789-04	17-22
12789-05	17-22
12790-04	17-34
12790-05	17-34
12794-04	39-1
12795-00	2-10
12795-01	2-10
12810-00	13-11
12818-00	9-25
12818-01	9-25
12836-02	28-5
12836-03	28-6
12838-02	28-44
12844-04	18-12
12845-00	18-14

Part Number	Figure and Index No.
12847-00	4-52
12855-00	10-26
12875-00	18-15
12914-00	12-14
12944-00	22-28
12955-00	14-1
12956-04	23-11
12982-00	42-20
12983-00	41-6
12998-03	18-10
13003-00	23-17
13029-00	25-7
13029-01	25-7
13072-06	4-9
13091-00	9-48
13093-00	10-13
13129-04	12-3
13129-05	12-2
13171-00	5-76
13179-00	30-5
13180-00	30-3
13241-00	8-15
13241-00	8-19
13300-00	12-4
13305-00	12-5
13373-02	9-58
13373-04	9-59
13416-02	15-2
13416-02	16-2
13433-02	9-61
13471-03	10-24
13483-00	9-68
13541-04	14-21
13541-04	15-6
13541-04	16-8
13541-16	14-20
13621-04	15-3
13621-04	16-3
13716-00	25-23
13717-00	25-26
13720-04	23-48
13725-07	23-47
13726-00	23-57
13729-00	35-4
13729-00	35-7
13731-04	35-3
13731-04	35-6
13733-04	35-2
13733-04	35-5
13735-00	35-8
13743-00	13-2
13745-00	36-2
13764-00	2-41
13764-00	14-22
13903-00	9-65
13914-00	9-63
14055-00	14-6
14056-00	14-4

Part Number	Figure and Index No
14059-00	9-11
14060-00	9-12
14061-00	9-14
14064-00	29-9
14065-00	29-7
14066-00	30-19
14070-00	30-21
14072-00	30-15
14073-00	25-30
14075-00	9-13
14088-02	18-5
14093-00	18-6
14094-00	18-7
14161-00	4-24
14174-00	23-34
14177-00	42-6
14180-02	42-5
14182-00	4-39
14192-00	4-19
14207-00	28-1
14208-00	28-2
14209-00	28-3
14211-00	28-8
14216-00	10-4
14222-00	5-54
14222-02	5-22
14224-12	29-3
14225-00	30-20
14226-02	29-1
14232-02	5-8
14235-00	23-20
14236-00	25-21
14239-00	23-85
14261-00	4-50
14271-00	4-38
14275-00	9-62
14291-00	4-55
14291-01	4-56
14300-19	37-1
14300-27	39-2
14300-28	37-4
14308-00	11-12
14337-05	10-20
14337-05	33-6
14340-00	12-30
14361-02	5-43
14361-03	5-44
14371-02	5-46
14371-03	5-47
14382-04	5-3
14382-05	5-3
14385-00	5-1
14385-01	5-1
14387-00	4-5
14387-01	4-6
14389-00	4-7
14389-01	4-8
14391-04	5-74

# PIPER PARTS CATALOG

Part Number	Figure and Index No
14391-05	5-74
14392-04	5-75
14392-05	5-75
14394-02	4-1
14394-03	4-1
14400-04	2-7
14400-05	2-7
14401-03	4-59
14401-04	4-61
14401-05	4-63
14401-08	4-57
14411-02	4-58
14411-03	4-60
14411-04	4-62
14422-00	24-1
14424-00	24-2
14426-00	24-3
14428-00	28-31
14434-02	23-24
14435-00	9-69
14440-00	26-6
14441-00	23-37
14444-00	23-2
14452-00	26-3
14455-00	26-1
14456-00	26-2
14457-00	26-4
14458-05	26-7
14461-00	4-18
14467-07	26-8
14470-00	28-53
14510-00	29-15
14513-00	26-11
14549-00	23-61
14570-00	22-20
14570-01	22-20
14571-00	4-53
14571-01	4-54
14581-00	4-45
14611-00	4-46
14611-01	4-47
14621-00	4-48
14621-01	4-49
14624-00	23-55
14773-05	31-17
14785-03	32-16
14786-00	32-2
14786-01	32-2
14787-03	32-1
14849-02	9-6
14890-03	29-10
14895-00	21-1
14941-06	5-41
14941-07	5-42
14977-00	21-42
14978-00	9-29
14979-00	9-32
14983-03	9-30

Part Number	Figure and Index No.
14984-02	9-31
15005-00	23-5
15007-00	23-4
15008-00	25-11
15008-01	25-11
15009-00	25-20
15010-00	25-13
15012-00	25-10
15018-00	25-12
15019-00	23-89
15020-00	23-88
15166-02	33-5
15216-00	23-28
15225-03	28-28
15271-08	9-55
15271-08	33-6
15271-08	34-6
15281-00	34-1
15299-00	14-27
15300-00	14-26
15318-00	34-7
15491-02	29-20
15503-02	29-2
15504-02	29-12
15529-02	26-5
15530-02	23-90
15530-02	26-13
15572-04	5-4
15572-05	5-4
15631-02	4-41
15631-02	8-12
15631-03	4-40
15723-00	4-10
15723-01	4-11
15726-02	17-43
15761-00	3-9
15831-02	5-72
15831-05	5-73
15857-02	31-15
16141-00	5-79
16462-00	5-33
16472-00	5-35
16551-00	4-15
16561-00	4-16
16601-00	4-14
16611-00	4-13
16775-00	14-3
16775-00	14-8
16775-00	14-16
16860-00	30-30
17604-30	29-5
17766-65	28-22
18049-34	33-1
18049-43	33-1
18307-00	28-52
18379-00	7-22
18576-06	29-16
18875-07	14-24

Part Number	Figure and Index No
18875-07	35-1
19657-00	2-2
19807-00	33-31
20391-00	11-44
20491-02	11-36
20491-03	11-35
20551-00	11-43
20611-02	11-39
20631-00	11-41
20652-00	11-33
20751-00	11-51
20841-00	11-16
20841-01	11-16
20951-00	11-18
20951-01	11-18
20961-00	11-19
20961-01	11-19
20981-02	11-50
21161-00	11-37
21272-03	11-9
21571-00	11-14
21571-01	11-13
21752-02	11-26
21752-03	11-2
21811-03	35-9
21879-02	34-5
22369-04	30-7
22369-23	30-17
22369-23	30-18
22412-00	11-38
23969-03	29-32
24032-22	9-28
24101-00	11-3
24121-02	11-1
24121-03	11-5
24918-00	18-29
25230-00	27-9
25801-05	12-1
30491-00	18-32
30531-02	21-40
30541-02	21-40
30602-07	18-1
31322-05	18-11
39273-03	43-7
39995-35	23-55
40071-00	36-15
40071-00	38-5
40081-00	8-7
40081-00	36-16
40081-00	37-14
40081-00	38-6
40092-10	4-27
40123-78	36-1
40123-89	36-1
40131-02	17-10
40261-00	35-12
40451-02	6-3
40451-02	6-4

Part Number	Figure and Index No
40451-02	6-9
40451-02	7-3
40451-02	7-4
40451-02	7-12
40451-03	6-3
40451-03	6-4
40451-03	6-9
40451-03	7-3
40451-03	7-4
40451-03	7-12
40451-06	6-4a
40451-07	6-4a
40501-00	2-17
40501-00	7-11
40592-00	10-23
40622-07	17-43
40701-00	8-8
40701-00	37-13
40721-00	40-5
40731-00	37-12
40731-00	40-6
40821-03	42-1
40842-04	13-7
40842-05	13-8
40941-00	13-4
40991-00	37-9
41001-00	36-11
41001-00	39-6
41031-02	17-3
41031-03	17-18
41051-00	17-6
41051-00	17-21
41121-00	41-3
41151-00	41-5
41271-02	36-4
41291-00	4-64
41371-02	35-10
41371-03	35-10
41371-04	35-10
41491-00	14-12
41521-00	22-23
41531-00	22-22
41551-00	14-13
41581-04	22-16
41631-00	42-13
41671-17	40-1
41671-19	40-1
41881-00	2-16
41881-00	7-9
41881-02	2-13
41881-02	6-8
41891-00	2-15
41891-00	7-10
42664-03	40-2
42692-00	42-14
42722-02	37-5
42722-02	36-3
42722-02	36-6

# PIPER PARTS CATALOG

Part Number	Figure and Index No
42722-02	37-2
42722-02	39-3
42891-00	41-2
42911-00	40-7
42961-02	42-7
43001-00	40-3
43001-00	42-21
44235-00	30-28
44291-02	31-8
44296-17	Misc
48659-11	33-11
49977-86	32-3
50042-00	13-10
50111-00	12-19
50131-00	10-2
50183-11	10-1
50192-00	10-5
52745-00	10-27
52841-22	10-7
52841-24	10-7
52841-26	10-7
54800-54	43-1
55549-02	17-51
60291-02	41-1
60401-04	6-11
60401-05	6-11
60571-00	9-3
60571-01	9-3
60602-00	10-22
60671-00	3-8
60703-02	18-37
60704-02	43-8
60708-02	6-5
60708-02	7-5
60708-03	7-6
60708-04	7-7
60708-05	7-8
60708-06	6-6
60709-02	2-11
60709-02	6-1
60709-03	2-11
60709-03	6-1
60709-06	6-10
60709-08	6-12
60709-09	6-12
60709-10	6-13
60709-11	6-13
60709-12	6-14
60709-13	6-14
60709-14	6-2
60709-15	6-2
60709-18	6-15
60714-02	2-14
60714-02	7-1
60714-03	2-14
60714-03	7-1
60714-04	7-13
60714-05	7-13

Part Number	Figure and Index No
60714-06	7-14
60714-07	7-14
60714-08	7-15
60714-09	7-15
60714-10	7-16
60714-11	7-16
60714-12	7-17
60714-13	7-17
60714-14	7-18
60714-15	7-18
60714-16	7-2
60714-17	7-2
60714-26	7-23
60714-27	7-20
60714-28	7-20
60714-29	7-19
60714-30	7-19
60717-02	Misc
60726-02	23-53
60727-03	30-25
60748-03	7-21
60750-02	2-24
60752-00	2-18
60753-02	10-29
60754-04	30-26
60756-02	28-60
60762-02	2-42
60762-02	33-2
60763-02	28-15
60765-02	28-36
60766-02	29-34
60863-03	3-10
60863-03	9-20
60863-05	9-21
60863-09	3-11
61323-10	14-18
61340-00	17-20
61341-02	17-5
61341-03	17-4
61341-04	17-19
61342-00	17-17
61541-36	27-2
61964-02	28-43
62177-03	15-3
62177-03	16-3
63901-44	23-31
64834-00	9-24
64835-00	9-4
64835-01	9-4
66673-00	27-9
66696-00	29-33
66752-00	15-9
66752-00	16-15
69015-77	27-25
69015-78	27-26
70371-02	23-9
70371-03	23-10
71061-04	22-17

Part Number	Figure and Index No
71261-05	23-27
71261-07	23-84
71991-00	28-37
72091-00	2-36
72302-03	28-33
73451-03	23-6
74181-00	2-27
74912-00	26-10
79399-00	27-1
80002-27	23-80
80002-41	8-9
80012-03	5-52
80012-03	37-8
80012-04	36-14
80012-04	37-10
80012-04	38-4
80012-04	40-8
80012-04	41-12
80012-04	42-22
80012-17	17-30
80022-20	11-34
80022-31	5-10
80022-44	17-49
80022-45	17-50
80022-63	18-23
80022-68	23-14
80032-34	23-12
80032-34	23-12
80032-51	14-15
80032-51	23-30
80032-69	28-51
80111-00	2-25
80122-07	9-26
80122-07	22-14
80122-10	13-6
80122-10	29-17
80122-11	4-68
80122-11	22-13
80122-17	35-11
80122-18	36-12
80122-18	38-3
80122-18	40-4
80122-18	41-10
80122-18	42-22
80122-24	42-11
80122-25	5-9
80122-30	21-3
80122-41	21-39
80122-41	42-8
80122-43	9-27
80122-43	23-71
80122-49	9-18
80122-51	3-5
80122-51	9-19
80122-53	2-7
80122-53	9-17
80122-53	17-24
80122-53	17-36

Part Number	Figure and Index No
80122-53	17-44
80122-55	23-86
80122-55	24-7
80122-86	17-48
80132-10	12-22
80222-03	13-3
80222-03	22-24
80292-15	11-40
80380-02	31-16
80421-00	36-7
80421-00	37-7
80421-00	38-2
80421-00	41-11
80421-00	42-2
80421-00	42-16
80421-00	42-23
80541-02	3-6
80541-02	9-70
80687-02	43-10
80944-02	8-21
81102-02	17-2
81102-03	5-13
81102-03	5-18
81102-03	5-24
81102-03	5-29
81102-03	5-37
81102-17	23-70
81172-20	14-11
81232-15	3-3
81262-08	13-5
81262-08	22-21
81262-14	39-5
81262-36	37-3
81272-15	11-10
81332-09	11-11
81342-05	42-9
81342-08	42-12
81342-11	39-7
81342-20	14-10
81342-42	36-8
81342-42	37-11
81342-45	9-49
81342-56	30-16
81352-32	37-6
81381-00	42-17
81411-02	42-24
81761-04	41-9
81903-03	18-26
82332-26	23-29
82332-38	23-32
82341-02	11-31
82371-04	28-10
82371-06	2-30
82371-06	33-8
82371-07	2-29
82371-10	2-28
82371-36	28-48
82371-37	28-49



# PIPER PARTS CATALOG

Part Number	Figure and Index No
82371-56	23-35
82371-90	27-27
82461-00	9-5
82461-00	10-28
82732-08	23-13
82732-24	4-51
82732-72	17-13
83161-02	14-29
83161-02	14-19
83302-13	12-13
83481-00	10-9
84013-101	27-24
84013-102	27-15
84013-103	27-16
84013-104	27-19
84013-105	27-20
84013-106	27-14
84013-107	27-13
84013-108	27-22
84013-109	27-23
84584-09	29-27
84584-10	29-24
85012-04	13-9
85012-04	27-26
85012-05	13-9
85012-06	13-9
85012-12	42-10
85012-14	9-50
85012-32	28-32
85012-47	24-4
85012-48	21-2
85012-57	18-16
85012-78	3-4
85012-106	17-44
85061-00	11-17
85211-00	42-15
86062-79	17-41
86062-80	42-4
86092-15	10-6
86102-92	36-9
89190-04	5-57
89190-05	5-57
89191-02	5-70
89191-03	5-70
89192-04	5-56
89192-05	5-56
89193-04	5-58
89193-05	5-58
89195-04	5-59
89195-05	5-59
89195-06	5-60
89195-07	5-60
89195-08	5-61
89195-09	5-61
89195-10	5-63
89195-10	5-64
89195-10	5-66
89195-10	5-67

Part Number	Figure and Index No
89195-10	5-68
89195-11	5-63
89195-11	5-64
89195-11	5-66
89195-11	5-67
89195-11	5-68
89195-12	5-69
89195-13	5-69
89196-02	5-62
89196-03	5-62
89196-02	5-65
89196-03	5-65
89201-02	8-14
89201-02	8-17
89202-02	8-13
89203-02	8-16
89215-02	5-71
89215-03	5-71
89216-02	14-28
89228-02	29-22
89232-02	4-37
89240-02	23-91
90797-02	28-59
90797-13	30-2
91193-00	23-8
97288-00	21-44
99003-08	16-9
99479-02	9-67
101 980	23-18
159 119	21-45
180 497	2-23
180 497	10-21
180 497	28-7
180 808	25-25
180 810	9-33
187 610	10-12
189 080	29-4
189 080	29-6
189 534	28-9
189 625	32-14
400 002	18-36
400 003	17-29

Part Number	Figure and Index No
400 004	21-42
400 211	23-67
400 212	18-3
400 213	18-4
400 219	18-19
400 220	18-18
400 262	21-4
400 321	23-63
400 438	8-3
400 440	17-25
400 443	4-65
400 443	17-40
400 444	17-37
401 194	2-9
401 195	2-8
401 266	17-14
401 266	17-26
401 274	17-12
401 315	17-9
401 334	20-12
401 355	8-18
401 359	18-2
401 366	8-20
401 400	23-76
401 405	21-39
401 450	12-31
401 918	23-7
404 100	17-33
404 103	18-4
404 103	23-68
404 105	23-64
404 395	8-15
404 395	8-19
404 838	19-18
404 856	12-33
404 888	18-36
404 888	21-42
404 888	20-15
404 889	2-8
404 889	2-9
404 889	18-2
404 890	18-18
404 890	18-19
404 890	21-39
406 355	15-19
406 355	16-27
406 386	15-16
406 386	16-28
406 681	8-3
406 681	17-7
406 681	17-15
406 681	17-28
406 681	17-39
406 682	17-11
406 682	17-32
406 683	8-20
406 683	8-18
406 683	23-77

Part Number	Figure and Index No
406 685	21-6
407 120	18-31
407 142	15-20
407 142	16-29
407 564	4-67
407 564	8-3
407 564	17-8
407 564	17-27
407 564	17-38
407 565	2-39
407 565	17-31
407 565	20-14
407 566	2-8
407 566	2-9
407 566	8-18
407 567	12-32
407 567	18-2
407 567	18-4
407 567	18-18
407 567	18-19
407 567	21-39
407 568	21-5
407 585	2-40
407 585	19-16
407 585	20-13
407 586	18-2
407 587	18-18
407 587	18-19
407 587	19-19
415 531	18-30
416 995	24-5
416 995	24-6
418 581	15-18
418 581	16-26
419 474	15-15
419 474	16-24
422 604	4-34
422 604	4-44
424 051	17-47
424 059	8-15
424 059	8-19
424 059	18-4
424 059	23-65
424 059	23-69
424 065	18-33
424 217	2-38
424 224	17-46
434 132	28-50
434 134	23-43
434 134	23-45
434 142	18-8
434 142	23-44
434 142	25-22
434 144	18-9
450 035	29-8
450 628	15-8
450 628	16-14
450 742	30-32

## PIPER PARTS CATALOG

Part Number	Figure and Index No
450 996	23-1
451 103	28-16
451 709	22-1
451 710	22-1
451 735	18-28
451 855	23-46
451 881	27-10
452 335	4-26
453 126	4-12
453 640	25-29
453 647	23-60
454 118	23-3
454 638	29-30
454 658	29-26
454 738	29-23
454 738	31-13
454 738	33-7
454 739	29-31
454 832	27-17
454 873	23-39
454 887	29-40
454 888	12-15
454 890	23-33
454 925	30-11
454 927	23-40
454 933	23-49
454 983	2-31
454 983	27-11
454 983	33-9
454 987	27-6
455 151	29-21
455 158	23-87
455 168	23-58
458 892	28-23
458 895	28-24
458 898	23-51
458 931	23-50
458 932	23-52
458 940	2-35
458 940	33-10
458 958	27-4
459 130	17-35a
459 131	2-7a
459 132	17-23a
459 133	17-43a
459 134	9-1a
459 135	18-21
459 848	13-12
460 649	2-34
460 651	28-27
460 652	28-18
460 653	28-42
460 654	28-41
460 659	28-23
460 661	28-24
460 661	28-40
460 663	22-18
460 677	18-38

Part Number	Figure and Index No.
460 683	28-20
460 684	28-19
460 689	28-25
460 693	42-25
463 368	25-4
463 368	25-19
463 368	30-4
463 369	25-17
468 340	28-21
470 648	30-23
471 053	14-9
471 053	15-14
471 053	16-23
471 060	14-2
471 060	14-17
471 060	14-23
471 060	15-12
471 060	16-19
471 077	9-64
472 036	34-3
472 660	30-1
472 661	4-2
472 661	32-6
472 665	31-1
472 666	31-4
472 681	21-46
472 736	30-12
472 963	31-12
476 640	28-26
476 652	2-43
476 664	23-52
477 673	15-17
477 673	16-25
477 829	43-11
480 691	18-17
480 731	41-8
484 341	25-15
484 373	29-35
484 654	23-54
484 854	23-56
484 698	19-10
485 080	27-7
486 596	15-4
486 596	16-4
487 149	29-13
487 272	12-25
487 274	12-24
487 274	12-28
487 288	25-6
487 288	25-24
487 288	25-28
487 288	30-6
487 328	39-4
487 350	33-13
487 550	15-10
487 550	16-17
487 550	30-22
487 558	18-13

Part Number	Figure and Index No.
487 563	25-2
487 563	30-4
487 565	25-3
487 565	25-18
487 566	25-16
487 726	33-12
487 777	34-4
487 791	29-28
487 791	29-29
487 791	31-14
487 793	29-25
487 823	14-25
488 374	28-39
491 947	28-45
492 022	28-30
492 023	22-10
492 272	27-8
514 751	15-16
514 751	16-28
515 714	15-17
515 714	16 25
548 314	16-6
548 330	15-7
548 330	16-12
548 459	16-10
548 868	16-5
548 886	16-16
550 684	16-11
551 727	18-35
551 727	19-1
551 771	18-34
551 771	20-1
554 778	2-32
554 778	28-47
554 802	27-3
554 871	2-33
554 871	28-46
554 947	23-36
558 819	18-39
558 900	27-5
558 913	27-12
565 288	30-29
587 965	43-9
588 428	27-18
588 567	27-21
597 257	43-6
599 178	16-6
750 063	20-11
750 272	28-35
750 273	28-34
750 283	11-52
750 284	11-53
750 295	22-9
750 379	22-6
750 384	22-8
750 386	22-4
750 387	22-5
750 746	21-36

Part Number	Figure and Index No
750 749	21-30
750 750	21-35
750 997	22-3
750 998	22-2
750 999	22-2
751 201	31-5
751 202	31-2
751 203	30-13
751 264	21-22
751 265	21-32
751 349	30-33
751 350	21-10
751 376	11-32
751 381	31-3
751 381	31-6
751 402	19-17
751 450	19-15
751 492	22-27
751 767	33-3
751 806	21-28
751 964	21-37
752 475	22-19
752 494	23-59
752 688	22-7
752 749	19-2
752 788	22-15
752 791	22-11
752 798	22-12
752 826	19-4
752 888	21-11
752 965	19-12
752 966	19-11
752 978	11-23
752 979	11-64
752 982	21-12
752 983	21-13
753 127	21-9
753 207	21-15
753 208	21-19
753 209	21-33
753 341	30-14
753 403	21-14
753 404	21-27
753 405	21-29
753 406	21-34
753 850	19-13
753 914	21-21
753 915	21-26
754 615	20-6
754 825	9-1
754 849	20-8
754 850	20-9
755 042	31-11
755 049	33-4
755 200	31-9
755 830	19-6
755 878	21-18
755 879	21-25



---

**PIPER PARTS CATALOG**

**GRIDS 1G20 THRU 1L24 INTENTIONALLY LEFT BLANK**