

# 101 Receiving Circuits

[www.rexresearch.com/xtlradio/xtlradio.htm](http://www.rexresearch.com/xtlradio/xtlradio.htm)

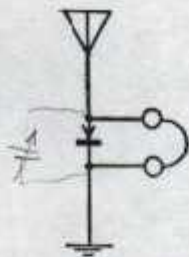

①

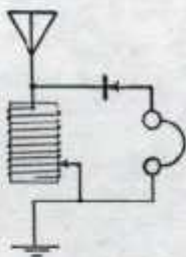

②

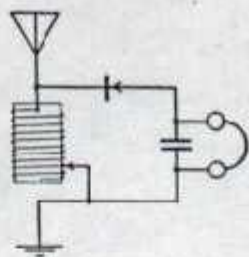

③

1. This is the simplest of radio receiving circuits. A crystal detector is placed between the antenna and ground, and the telephones are shunted around it. Signals on wavelengths nearest that of the natural period of the antenna will be received strongest, altho none will be heard with intensity as great as where a tuner is employed, on account of the aerial circuit being highly damped by the presence of the detector.

2. In this circuit we have a variable inductance inserted between the antenna and ground for the purpose of tuning the aerial wire system to the wavelength of the transmitter from which reception

the reception of broadcasted radio concerts.

3 Here we have a system very similar to the previous one, except that a fixed condenser is shunted across the telephones. This has a capacity of about 0.001 mfd. and is usually referred to as a stopping condenser or a phone condenser. Its purpose is to store up energy while the current is flowing thru the detector and discharge it thru the telephones during the opposite alternation.

4. This shows another means of connecting the same instruments employed in circuit 3. The tuning inductance occupies the same position, and a fixed condenser and detector are shunted around

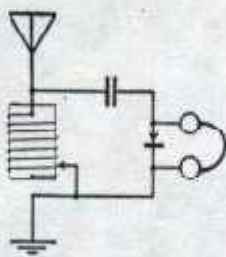

④

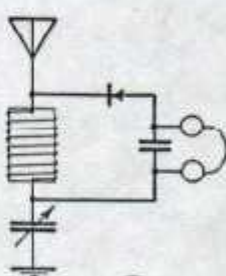

⑤

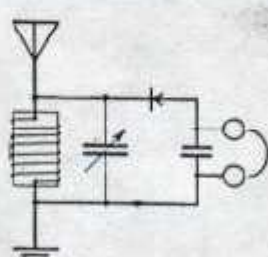

⑥

is desired. The telephone and detector are placed in series across the inductance for the purpose of rectifying and converting into sound the wave trains traveling thru it. This is a marked improvement over circuit No. 1, for the high resistance detector is removed from the antenna circuit, and the tuning coil permits adjustments to various wavelengths without undue interference from others. This circuit is employed in most of the lower priced receiving outfits now marketed for

it, but the telephones are connected across the crystal detector rather than across the condenser. With some crystals better signals are obtained with the telephones in this position while with others the opposite is true.

5. In this circuit tuning is accomplished by means of a variable condenser placed in series with the ground. For a limited range of wavelengths the inductance can be fixed, and may either take the form of a simply wound solenoid or a honey-

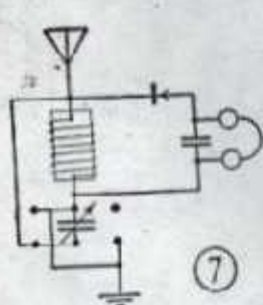

(7)

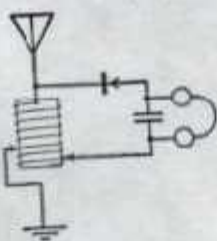

(8)

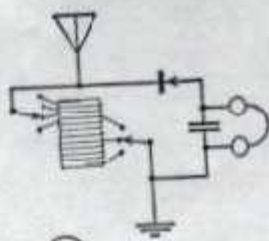

(9)

comb coil. With the condenser in series, no wavelength can be obtained as great as if the condenser were omitted, and the lower the capacity used, the shorter will be the wave to which the set is tuned.

6. Again we have variations in wavelength of the receiver made possible by the use of a variable condenser. The inductance of fixed value is connected between the antenna and ground with the variable capacity across it. With this arrangement only wavelengths greater than that which would obtain if the condenser were removed, can be tuned in. It is not as selective as circuit 5, and with the majority of antennas it is found that two wavelengths are almost always covered by systems of this kind.

7. Since by the use of circuit 5 we get variations of wavelengths below that resulting from the effect of the antenna, inductance and ground alone, and wavelengths above that by employing circuit 6, many experimenters use a switch for changing the

8. This is a simple circuit for a two slide tuning coil. While all of the hook-ups previously shown have but one tuned circuit, this one has two, which are conductively coupled to each other. The antenna circuit is tuned by the slider connected to the ground, while the secondary or closed circuit is adjusted by the other slider. Tuning of a little more selective variety is the advantage of this type of receiver over the single slide outfits.

9. Again we have a single circuit tuner but in this case the use of taps rather than sliders on the inductance is illustrated. In order to get any number of turns, from the first to the last, it is necessary to use two switches. At one end the coil is tapped for one switch at every turn until a number equal to the square root of the total number of turns on the coil, is taken off. The points of the second switch are connected to taps which are separated by a number of turns equal to the number of taps on the first switch. The advan-

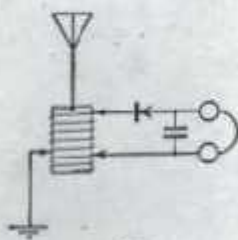

(10)

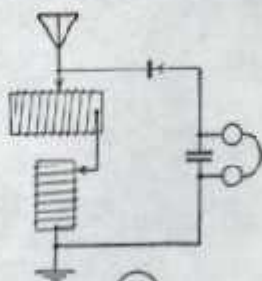

(11)

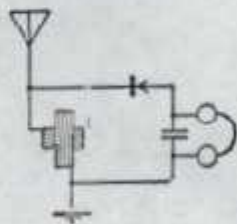

(12)

variable condenser from one position to the other in order to cover the whole wavelength range with but one set of instruments. Here we have a simple method for accomplishing this. The variable condenser is connected across the two blades of a D.P.D.T. switch, the antenna on one pole, ground on two diagonally opposite poles, while the fourth one is left dead. By throwing the switch to the left the condenser is placed in parallel with the inductance, and when in the opposite direction the capacity is inserted in the ground lead.

sage of this system of tapping the coil is that it gives the minimum number of switch points that may be used to give one turn variations of inductance throughout the length of the coil.

Switches have gradually replaced sliders on variable inductances because they permit the instrument to be conveniently mounted on a panel, prevent the wearing of the wire and the short circuiting of turns due to metallic particles getting between them, make adjustments easier, reduce the capacity effect of the operator's hand by keep-



ing it farther from the coil, and make contacts which are less affected by dust.

10. This circuit shows the connections of a receiving outfit employing a three slide tuner. This may be considered a two circuit tuner, conductively, but variably coupled. The primary or antenna circuit is tuned by changing the position of the ground slider, the secondary is tuned by varying the distance between the other two sliders, and the coupling may be altered by moving the secondary sliders together, to or from the antenna end of the inductance. It is evident that when the number of turns separating the secondary sliders is comparatively small, a greater range of coupling may be obtained. This circuit gives the greatest selectivity of all single winding tuners.

11. This diagram illustrates a means of increasing the wavelength of a single circuit receiver by the addition of a second inductance or loading coil. The two coils are placed in series and treated as but a single winding. For relatively long waves, when the last turn of the first inductance has been reached, the slider on the loading coil is moved

of the system, as the whole winding is in the circuit at all times. Opposed to these advantages, however, are the facts that all variometers have a limited range of inductance variation and since the resistance in the circuit always remains the same the efficiency is low when comparatively small values of inductance are used.

13. Because the minimum inductance obtainable in a variometer is comparatively large, it often happens that when this instrument is used as a tuner the wavelength at the lowest adjustment is longer than that of the desired signals. To overcome this difficulty and permit shorter waves to be reached, a condenser is placed in series with the ground lead. This may be of the variable type but if only a relatively narrow band of waves is to be covered, a fixed condenser will serve the purpose since the variometer is capable of fine adjustments to the incoming signals.

14. This circuit employs a variable condenser in shunt with a variometer for tuning the receiver. An arrangement of this sort is intended for wavelengths greater than those obtainable by the use

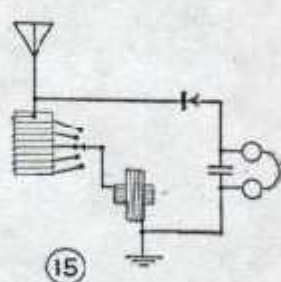
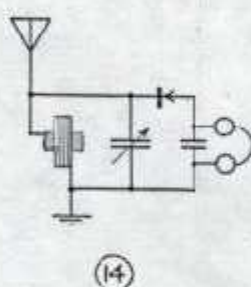
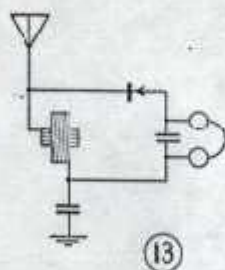

from its position of minimum inductance toward the opposite end until the desired wavelength is obtained. It is well to mount the two coils at right angles and several inches apart so that when the loading coil is not required, losses which would otherwise be high on wavelengths near its natural period will not be so greatly felt.

12. In this circuit another means of tuning is shown where a variable inductance of the variometer type is used for changing the wavelength of the system. The inductance of the circuit is altered by varying the mutual inductance between two coils connected in series and mounted in such a way that the self inductance of one may be made to assist or oppose that of the other. This gives gradual variations of wavelength and therefore has the advantage of permitting close adjustment to sharp waves. Another point of superiority over the types of inductance previously considered is that there are no dead ends to reduce the efficiency

of the variable inductance alone. As in circuit 13, a fixed capacity will suffice if a comparatively small range of wavelengths is to be covered, but otherwise a variable condenser should be used. Since the variometer provides for gradual changes in the wavelength of the outfit, the capacity may consist of a condenser which is varied in steps by means of a fan switch passing over contacts connected to the plates.

15. In this circuit we again make use of the quality of the variometer which permits minute variations of inductance. Here we have the variometer connected in series with a tapped loading coil. One set of switch points is all that is necessary, and the taps are separated by a value of inductance equal to the range of the variometer. In this way any degree of inductance may be obtained, from that of the minimum of the variometer to the total of the tapped coil plus the maximum of the variometer.

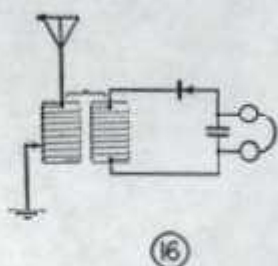

16. This is a simple loose coupler circuit showing a variable primary or antenna inductance inductively coupled to a secondary or closed circuit inductance of fixed value. A detector, fixed condenser and telephones completes the receiving system. Such a receiver is commonly referred to as having an aperiodic or untuned secondary, since it has but one possible value of inductance and no tuning condenser. The tuning is done by varying the primary inductance and the untuned secondary responds to all wavelengths to which the primary may be tuned. Altho the closed circuit has a high damping factor due to the absence of a condenser across the inductance terminals, it responds to different wavelengths with varying degrees of efficiency. The more nearly the wavelength of a desired transmitter approaches the natural period of the secondary of the loose coupler, the greater will be the transfer of energy from the antenna system to the detector circuit. By changing the inductive relation between the primary and secondary coils sharp tuning is secured. This feature

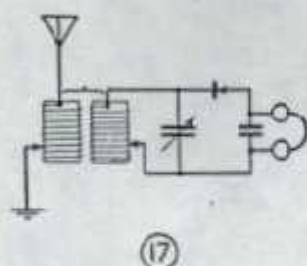

is the greatest advantage of the two circuit tuner over the single coil type.

17. In this diagram we have a loosely coupled receiving tuner with two tuned or periodic circuits. The wavelength of the antenna circuit is varied by changing the value of the variable primary inductance and the secondary may be placed in resonance with it by a selection of the proper values of the closed circuit inductance and variable tuning condenser. In cases like this where both circuits may be tuned to the frequency of an incoming signal, maximum transfer of energy between the circuits occurs and the loudest response in the telephones results. By altering the coupling between the two coils varying degrees of selectivity in tuning may be obtained.

Before the vacuum tube came into use this circuit was considered the best that could be used. In fact, at present it is surpassed by no other crystal detector circuit and is the fundamental wiring diagram of the best equipment used at sea.

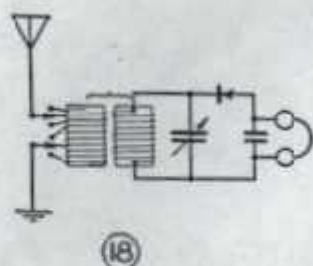

18. This circuit depicts the usual crystal detector, telephones and stopping condenser, connected to a loosely coupled two circuit tuner whose secondary inductance is of fixed value while the primary is varied by means of units and tens switches. A tuner of this type is usually built so that the coupling between the coils is varied by rotating the secondary inside the primary tube, and is commonly referred to as a vario coupler. It is a simple matter to vary the inductance of the

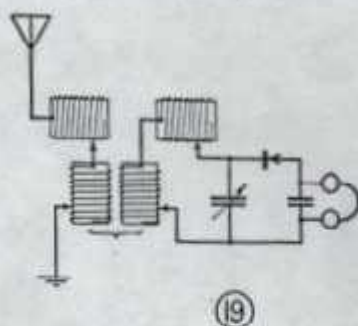

antenna coil by either a slider or switches, but since the closed circuit winding is arranged to be rotated, mechanical difficulties make variations in the inductance of the secondary practically out of the question. For that reason all of the tuning in the secondary circuit is accomplished by means of the variable condenser shunted across the winding.

19. In this figure a system for increasing the wavelength of a receiving outfit is shown. A



No. 96

# CRYSTAL SET CONSTRUCTION

SIMPLE INSTRUCTIONS FOR MAKING  
NINE CRYSTAL SETS

*by* **B. B. BABANI**

*There is to-day a marked revival of interest in crystal receivers, and this book has been specially prepared to introduce the home constructor to the design and building of the various types. The text is simple and free from technicalities, so that even the young reader may confidently embark on the construction of any of the receivers shown.*

## CONTENTS

- |                                     |   |
|-------------------------------------|---|
| 1. AERIALS.                         | 9. HIGH SELECTIVITY RECEIVER.           |
| 2. EARTHS.                          | 10. BATTERY AIDED CRYSTAL RECEIVER.     |
| 3. CRYSTAL DETECTORS.               | 11. MEDIUM AND LONG BAND RECEIVER.      |
| 4. COILS.                           | 12. ULTRA SENSITIVE ALL WAVE RECEIVER.  |
| 5. THE BEGINNERS' CRYSTAL RECEIVER. | 13. AN ADVANCED CRYSTAL DIODE RECEIVER. |
| 6. FRAME AERIAL RECEIVER.           |   |
| 7. LONG DISTANCE RECEIVER.          |   |
| 8. HIGH GAIN RECEIVER.              |   |

THERE ARE 12 DIAGRAMS

L O N D O N : BERNARDS (PUBLISHERS) LIMITED



VARIABLE CONDENSER



TUNING COIL



CRYSTAL DETECTOR

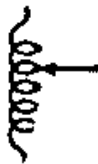

TUNING COIL WITH TAPPINGS



FIXED CONDENSER



SINGLE POLE DOUBLE THROW SWITCH



BATTERY POSITIVE SIGN



SINGLE POLE SINGLE THROW SWITCH



BATTERY NEGATIVE SIGN



DOUBLE POLE SINGLE THROW SWITCH



AERIAL

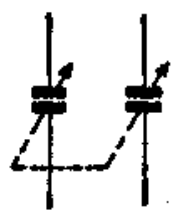

"TWO-GANG" VARIABLE CONDENSER



EARTH



PHONES



WIRES CONNECTED



WIRES NOT CONNECTED



FRAME AERIAL



SOCKET AND PLUG

FIG. 1 SYMBOLS USED IN THE CIRCUITS DESCRIBED.



## **I. Aerials.**

One of the essentials for satisfactory reception with crystal sets is an efficient aerial. Four different types are suggested and are shown in Fig. 2.

There are several important points to be noted when erecting an aerial for a crystal set.

(1) See that it is suspended as high as possible and is not screened by tall buildings, obstructions, etc.

(2) The aerial itself and the lead-in from the aerial must be adequately insulated. Be sure that the porcelain or plastic insulators do not permit the aerial or lead-in to touch the building, tree, or post from which they are suspended. The lead-in should be brought into the house through an insulated rod.

(3) It is exceedingly important to use insulated copper wire, either single or multi-stranded, for both the aerial and the lead-in.

## **2. Earths.**

An adequate and efficient earth contributes to the good performance of any well-designed crystal set and Fig. 3 shows the best method of obtaining an efficient earth where there is a garden or patch of ground available at a short distance from the receiver.

Obtain a 3-ft. length of  $\frac{1}{2}$ -in. galvanized iron pipe and at one end drill a hole right through. Insert a bolt with spring washer and locking nut in the hole. Connect the earth lead-in wire to the bolt; the other end of the lead-in to the earth connection on the receiver. Leave both ends of the pipe open. Insert the end opposite the bolt into the ground vertically until only 3-in. are showing above the surface of the surrounding earth.

It is important to see that the surrounding ground is kept damp, if necessary by occasionally pouring a pint or two of water down the open projecting end of the pipe.

Ready-made copper earthing rods with a pointed end for easy hammering into the earth are sometimes obtainable from radio dealers.

Should a garden not be available, an alternative earth is a cold water pipe coming from a rising main. Simply file very lightly the pipe at the back of the tap and wind the copper wire earth lead-in round the filed part and cover the joint with insulating tape.

In no circumstances should a gas pipe be used for an earth.

## **3. Crystal Detectors.**

Most radio dealers can supply very efficient permanent or semi-permanent crystal detectors of proprietary makes. However, there are always available quite a number of ex-Government surplus units which are called crystal valves and, though these were originally designed for a very different use in service equipment, they are easily adaptable and will give extremely efficient results when used in circuits designed for them. To enable the constructor to purchase suitable types for this purpose—and they cost very little—the following list gives the Government reference numbers.

CV 101, CV 102, CV 103, CV 111, CV 112, CV 113, CV 226, CV 241, CV 246, CV 247, CV 253, CV 291, CV 351, CV 361, CV 364, CV 367, CV 727, CV 749, and CV 1785.

One of the satisfactory proprietary makes of this class of crystal detector is the BTH CS7A, which, incidentally, is the commercial equivalent of the CV 253.

For all these Government types, one connection should be made to each end by arranging a holder to fix them into or by carefully soldering the appropriate connecting wires to each end.

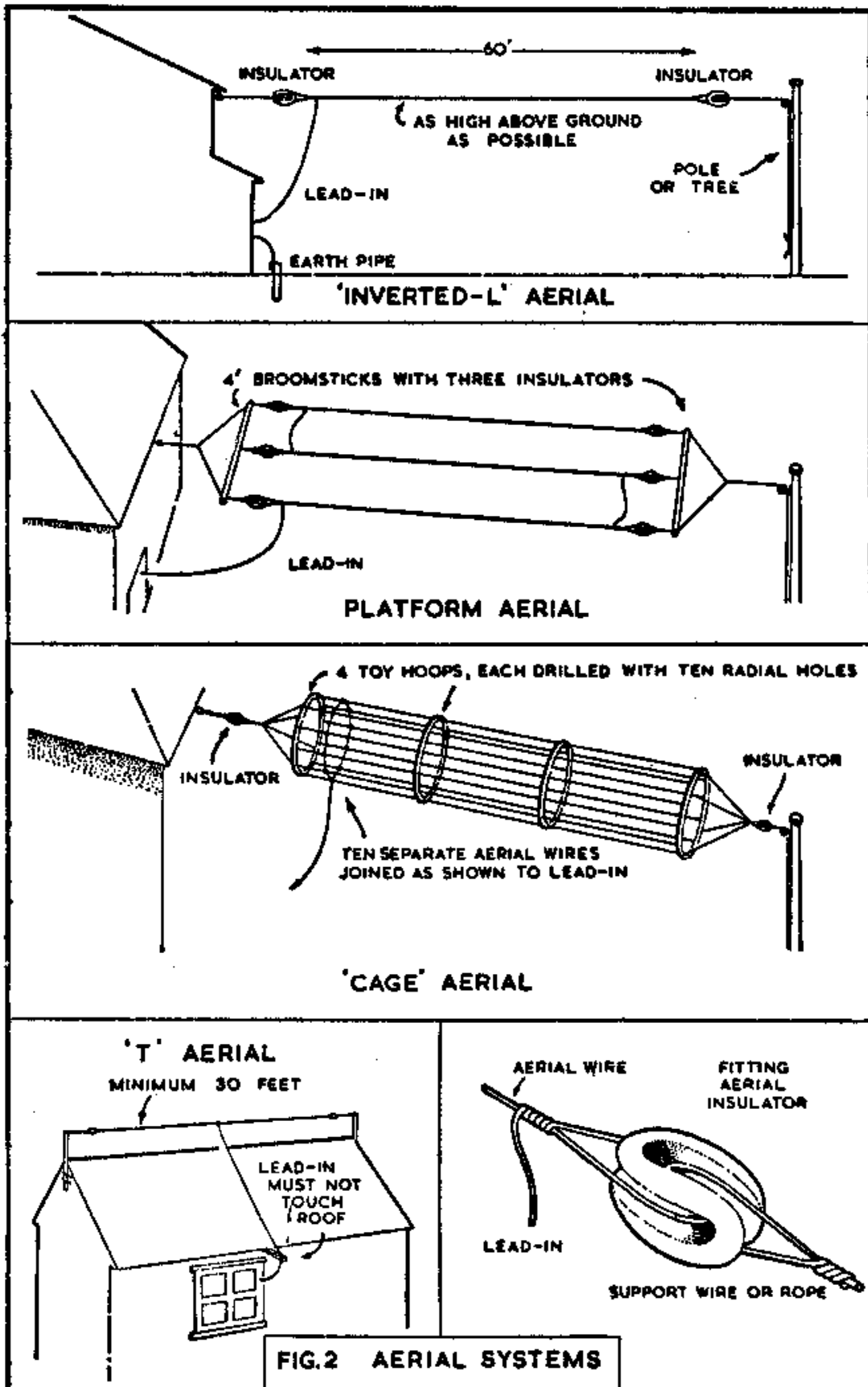



## 4. Coils.

In Fig. 3 two methods are shown of fixing the coil to the chassis. However, the ingenious constructor may evolve another arrangement.

The important thing to remember is that the coil should be fixed so that it is completely insulated from the metal chassis that may be used.

It is also important to remember that if a metal chassis is used, one must see that all components and wiring, with the exception of earth connections, are adequately insulated from this chassis so as to make sure that no short circuits take place. It is recommended that all crystal sets should be built on a panel, and that both panel and chassis should be of bakelite, paxolin or perspex, as these three materials are efficient insulators in themselves.

## 5. The Beginners' Crystal Receiver.

The popularity of the crystal receiver among beginners is undoubtedly due to the very modest outlay necessary, and the ease with which such receivers may be built. It is not always appreciated that, to obtain worth while results,

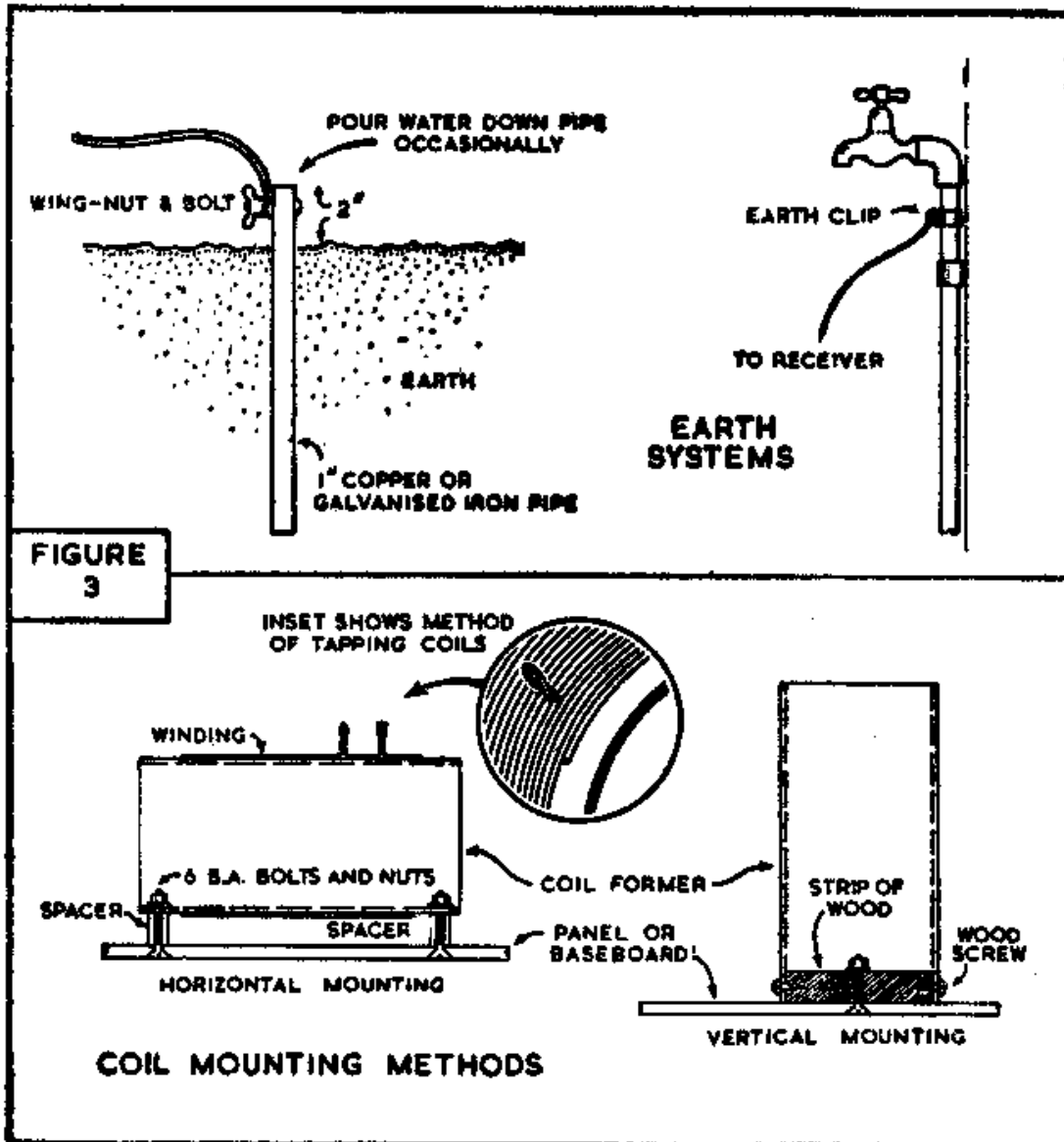

far more care in avoiding losses is necessary than with a three or four valve receiver. One reason for this is the fact that the crystal receiver can offer no help by way of amplification and it is therefore dependent on an efficient aerial/earth system, low loss design within the receiver itself, and the use of sensitive headphones. The experience gained is well worth the time expended since, when more ambitious receivers are attempted, the constructor will remember the benefits gained by efficient construction and installation with the result that each receiver attempted will be an instrument capable of giving a first class performance.

Losses within the receiver itself may be considerably reduced by efficient coil design. Unfortunately, selectivity is a factor which must not be overlooked; it is this factor which governs the sharpness of the tuning and permits the separation of adjacent powerful stations. The greater the selectivity, the greater the ease with which signals may be separated; but at maximum selectivity the received signals are at minimum strength. In Fig. 4, the coil is tapped at four points, which enables the best point between selectivity and sensitivity to be chosen. The nearer the aerial tap to the earth end of the coil, the greater the selectivity. The pre-set condenser C1 also aids selectivity; at minimum capacity the selectivity is high, and *vice versa*.

Used in conjunction with the coil taps, the constructor should have no difficulty in selecting a condenser setting and tapping point which permit the reception of strong signals and at the same time effect the required separation of powerful stations.

The coil is constructed on a former 3-in. diameter  $\times$  2-in., and consists of 50 turns 36 S.W.G. enamelled wire close wound and tapped at every tenth turn. These taps are brought out in the form of loops twisted firmly so that there is no actual break in the winding continuity. After completion the winding may be painted with Durafix to prevent any movement, and the taps and two free ends cleaned with emery cloth to remove the enamel. The layout and wiring is shown in Fig. 4. The headphones should have a resistance of some 4,000 ohms or more and should be of reputable manufacture. Any of the materials previously described are suitable for use with this receiver.

C2 .0005 variable condenser.	2 oz. 30 S.W.G. enamelled copper wire.
C1 .0002 pre-set condenser.	
C3 .001 mica condenser.	1 Coil former 3-in. dia. $\times$ 2-in.
1 Crystal detector, semi-permanent pattern.	1 Ebonite or Bakelite panel 6-in. $\times$ 5-in. $\times$ $\frac{1}{2}$ -in.
	4 terminals, connecting wire, etc.

### 6. Frame Aerial Receiver for Local Station use on Medium wave bands.

This receiver was specially designed for constructors who are within 5 to 10 miles of a powerful station and who have no facilities for constructing a good outdoor aerial.

The frame itself consists of two  $\frac{1}{2}$ -in.  $\times$   $\frac{1}{2}$ -in. square section wooden rods each 36-in. in length. These are placed together at their centre line to form a cross; they are fastened by a nut and bolt and these in turn pass through an upright piece of wood  $\frac{1}{2}$ -in.  $\times$  1-in. section 2-ft. in length. This upright support is then screwed into a baseboard 8-in.  $\times$  8-in.  $\times$  1-in. thick. At each of the arms of the 36-in. cross a 4-in. strip of  $\frac{1}{2}$ -in. square section wood is placed. Reference to Fig. 5B will give the details of the construction of this aerial quite clearly.

It will be noted that approximately 85-ft. of 20 S.W.G. double cotton-covered wire are required for the inductance to cover the medium wave broadcast band. The wire should be wound around the four crossbars, thereby creating



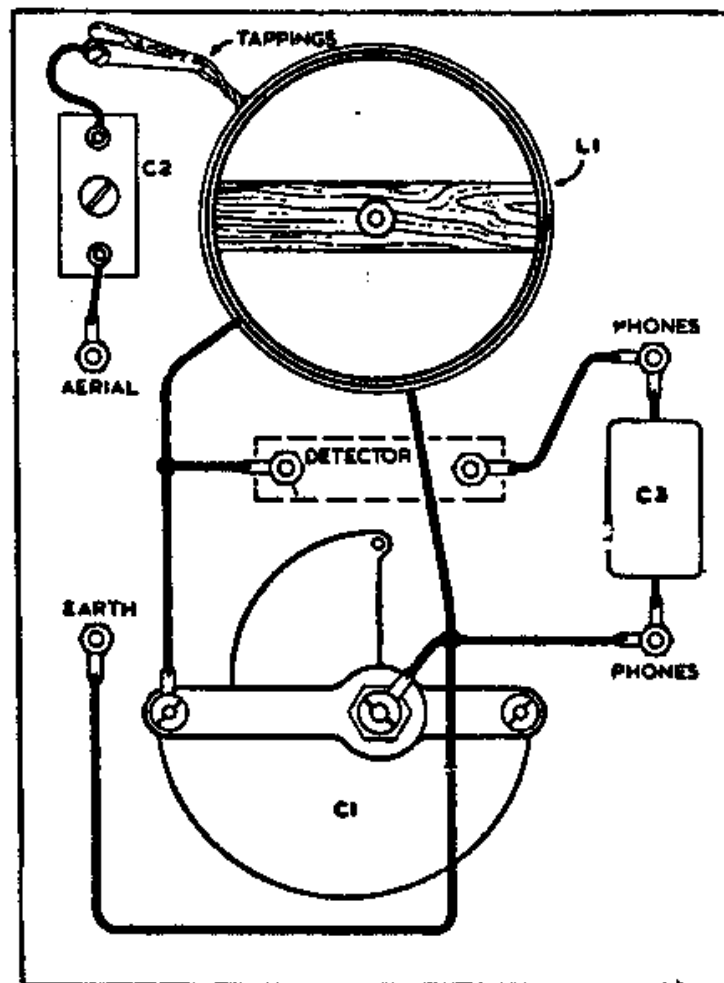
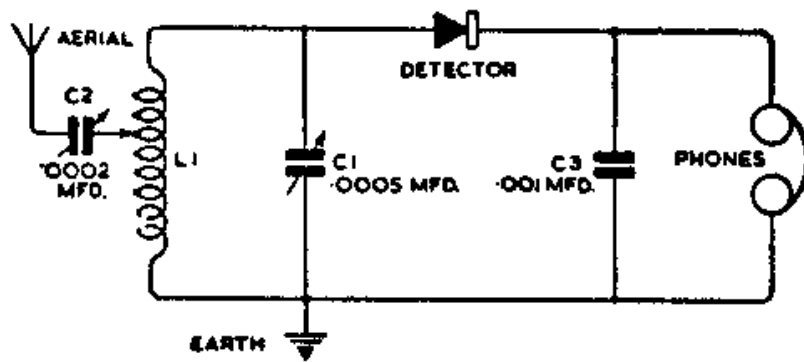

FIG. 4 THE BEGINNER'S CRYSTAL RECEIVER.

a square wire frame, and each turn of the wire should be spaced approximately  $\frac{1}{4}$ -in. The best way to effect this spacing accurately is to file on the 4-in. crossbars a number of small nicks at  $\frac{1}{4}$ -in. intervals. The two ends of the wire should then be brought down on the two terminals which may be screwed into the baseboard and two leads taken from there to the crystal set itself.

The actual set may be constructed on a small ebonite, paxolin or perspex panel 8-in.  $\times$  5-in. which may be screwed to one side of this base supporting piece of wood, thereby making the set virtually self-contained except for the earphones. Fig. 5A shows the circuit of the receiver.

To obtain the best results with this receiver, the aerial should be rotated by hand until the signals become loudest.

1 Semi-permanent crystal detector.	1 pair of high sensitivity earphones.
C1 1 .0005 mfd. variable condenser.	85-ft. to 90-ft. of 20 S.W.G. double cotton covered wire. (8oz.)
C2 1 .0005 mfd. fixed condenser.	Sufficient connecting wire for wiring purposes.
1 condenser dial marked 0 to 100 or 0 to 180.	

## 7. Long Distance Receiver.

This receiver has been specially designed to achieve high sensitivity. With a sufficiently good outdoor aerial effective reception has been obtained up to 150 miles.

The circuit is quite straightforward, as can be seen from Fig. 6 and the only special point is in winding the coil L1.

This coil consists of a 2 $\frac{1}{2}$ -in. diameter former on which are wound a total of 51 turns using 24 S.W.G. double cotton wire. Starting at one end, tap every two turns until there are eight taps; wind a further 15 turns and tap; then a further 10 turns and tap; finally, add 10 turns to end the winding. The wire should be close wound, *i.e.*, with turns touching.

To obtain the best results, the two crocodile clips A and B should be tried on the various coil taps until the loudest reception is obtained. It may be found in use that the loudest reception of any particular station causes another station to be heard at the same time; care should, therefore, be taken to select the appropriate tapping point to separate any two powerful stations that may interfere with one another.

4 oz. 24 S.W.G. DCC copper wire.	1 Permanent crystal detector.
Coil former 2 $\frac{1}{2}$ -in. dia. $\times$ 3-in.	C3 .001 fixed condenser.
C1-2 single variable condensers .00035 mfd.	1 pair of high sensitivity earphones (preferably between 4,000 ohms and 8,000 ohms impedance).
2 Condenser dials marked from 0 to 100 or 0 to 180.	2 Crocodile clips.

## 8. High Gain Receiver.

This receiver has been designed to give good reception up to 50 miles distance from any normal power broadcasting station in the medium band. It is a very selective circuit and will therefore enable the user to separate closely situated stations.

It will be noticed in the circuit (Fig. 7) that the variable condenser C1, has an on/off switch S1 to throw it out of circuit if necessary. It is used to increase the selectivity of the receiver and, in operating, it should be tried with this condenser either in or out of circuit on the various tappings on the coil L1.

L1 consists of 90 turns of 22 S.W.G. double cotton covered wire wound on a 2-in. diameter former and tapped every ten turns. L2 separately wound on a 2-in. former, consists of 90 turns of 22 S.W.G. double cotton covered wire, also tapped as L1. The components required are given on page 7



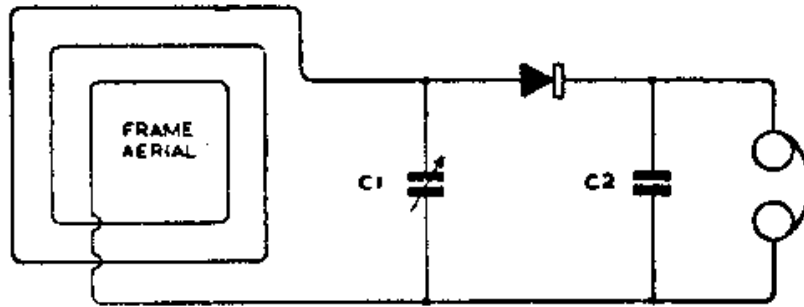

FIG. 5A FRAME AERIAL CRYSTAL RECEIVER

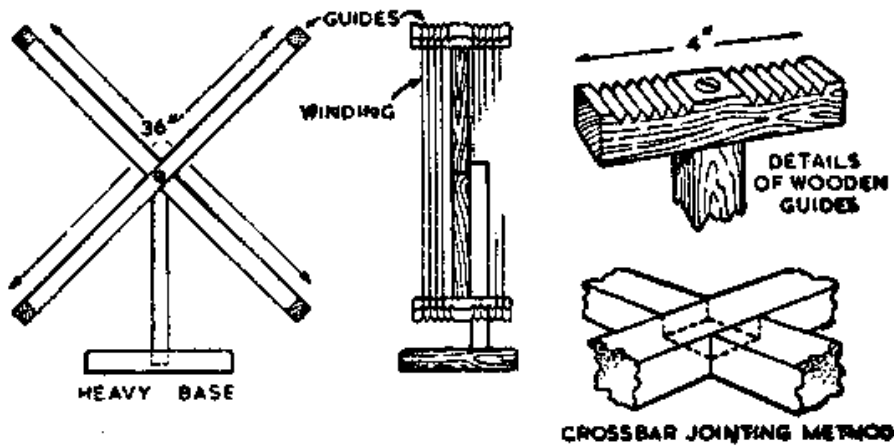

FIG. 5B. DETAILS OF FRAME AERIAL

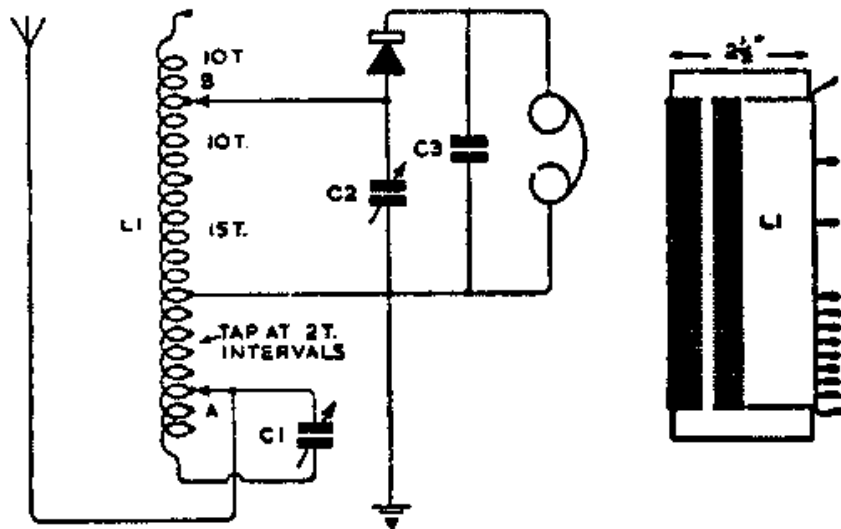

FIG. 6 LONG-DISTANCE CRYSTAL RECEIVER

- |  |  |
|--|--|
| C1-2 Single variable condensers<br>.00035 mfd. | 1 Pair of high sensitivity earphones.<br>8 oz. 22 S.W.G. DCC.  |
| S1 Single pole single throw switch.            | 2 Dials for variable condenser<br>marked 0 to 100 or 0 to 180. |
| C3 .0001 preset condenser.                     |  |
| 1 Permanent crystal detector.                  |  |
| C3-4 .001 mfd. fixed condenser.                |  |

## 9. High Selectivity Receiver.

This circuit (see Fig. 8) is for use in high saturation strength areas where it is desired to separate powerful stations. The circuit is not complicated and is extremely effective.

It will be noted that C1 and C2, each .00035 mfd. capacity, are 2 gang unit.

The only special point in this set is the design of coils L1, 2 and 3, which are constructed as follows: L1, 60 turns of 22 S.W.G. double cotton covered wire on a 3 x 4 inches former tapped every five turns; L2, 15 turns of 22 S.W.G. double cotton covered wire on a 3 x 6 former; and L3, 85 turns of 22 S.W.G. double cotton covered wire wound on the same former as L2, the two windings being separated by approximately 1/4-in. (see Fig. 8).

Note that the aerial lead is brought down to one of the tapings on wire L1. This should be tried on each of the tapings and the one giving the required selectivity should be used.

- |   |                                    |
|---|------------------------------------|
| C1-2 2-gang variable condenser<br>.00035 mfd. | C3 .0005 fixed condenser.          |
| 2 3-in. formers for coils L1-2-3.             | 1 Semi-permanent crystal detector. |
| 8 oz. 22 S.W.G. DCC.                          |                                    |

## 10. Battery-aided Crystal Receiver.

Fig. 9 shows a design which utilizes a 9-volt grid bias battery to improve performance.

The charge built up in the .02 mfd. fixed condenser is changed to a positive current when it passes through the coil L1. This, in turn, is superimposed on the positive charge that is commencing to be rectified by the crystal detector and thereby increases the signal strength.

Coil L1 consists of a 4-in. diameter former wound with 85 turns of 24 S.W.G. double cotton covered wire tapped at 5, 25, 45 and 65 turns from the earth end. The earth end and these four taps are brought out to five small sockets and the connection from the earth is taken to a small socket. The plug should be tried in each of the five positions to find which one gives the greatest signal strength.

The 9-volt battery is connected across the .02 mfd. condenser and special care should be taken to see that the battery is connected correctly, *i.e.*, negative pole to earth.

- |                                  |  |
|----------------------------------|--|
| 1 Permanent crystal detector.    | C3 Fixed condenser .02 mfd.            |
| 1 4-in. dia. x 3-in. former.     | 1 pair of high sensitivity headphones. |
| 8 oz. 20 S.W.G. DCC copper wire. | 1 Clix plug.                           |
| C1 Variable condenser .0005 mfd. | 5 Clix sockets.                        |
| C2 Fixed condenser .005 mfd.     | 1 9-volt grid bias battery.            |

## 11. Medium and Long wave band Receiver.

This set has been designed for reception on two wave bands.

Care must be taken in winding the coils L1, 2, 3 and 4. These are wound on a single 3-in. diameter former. L1 consists of 30 turns of 28 S.W.G. DCC tapped at 8, 16 and 24 turns. L2, 60 turns of 32 S.W.G. DCC. L3, 40 turns of 28 S.W.G. DCC, and L4, 80 turns of 32 S.W.G. DCC. All are close wound and are separated from each other as follows: between L1 and L2, 3/16-in.;

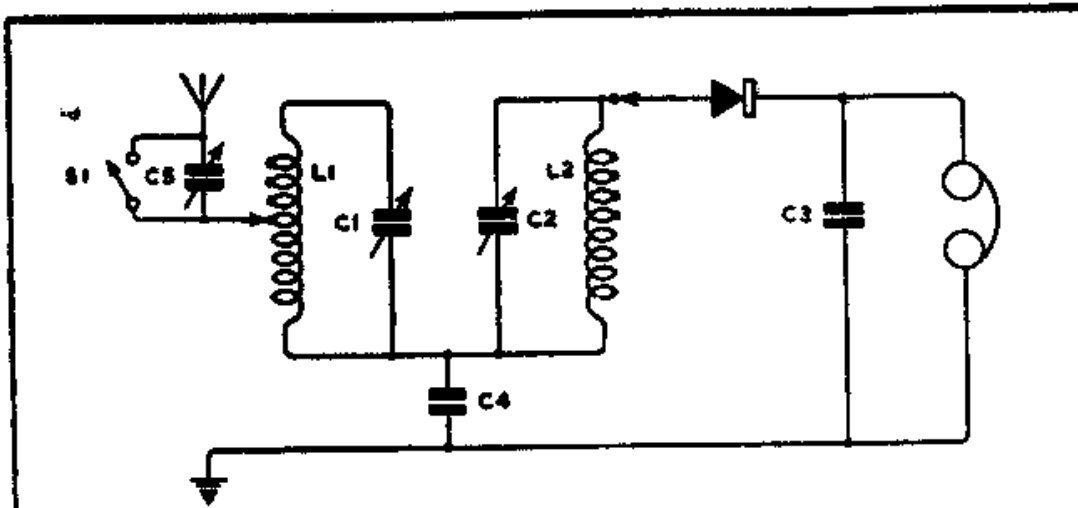

FIG. 7 HIGH-GAIN CRYSTAL RECEIVER

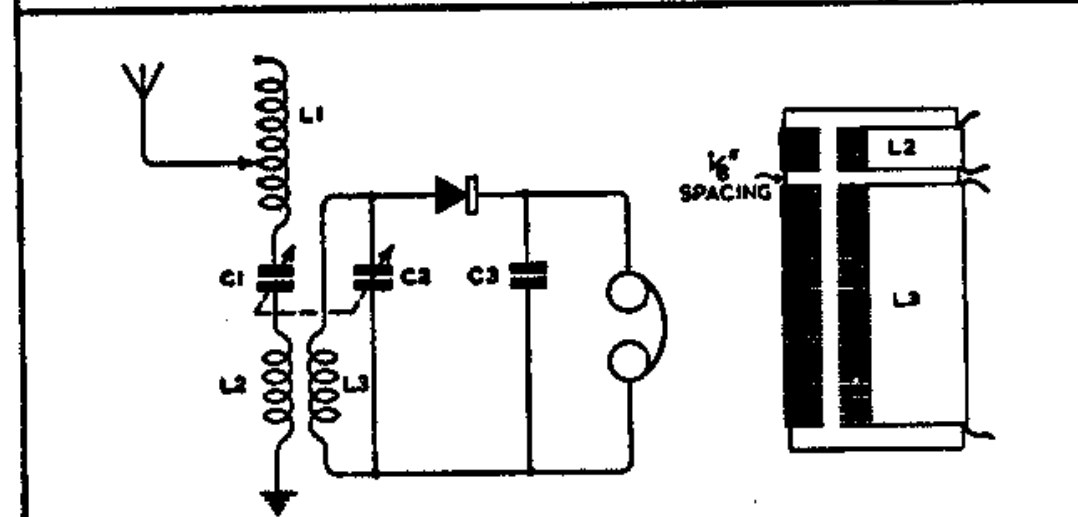

FIG. 8 HIGH SELECTIVITY CRYSTAL RECEIVER

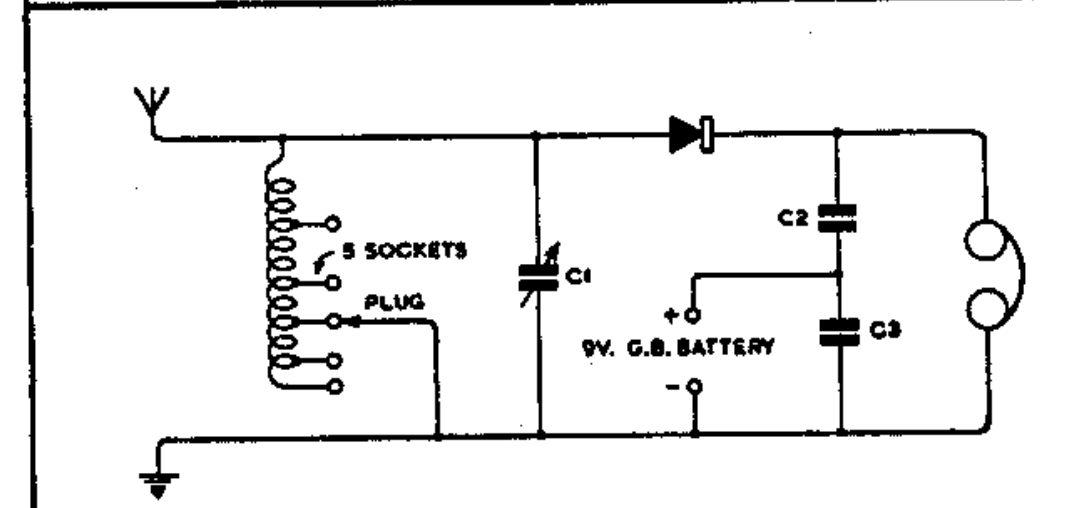

FIG. 9 BATTERY-AIDED CRYSTAL RECEIVER

between L2 and L3, 1-in.; and between L3 and L4, 3/16-in. See Fig. 10.

C1-2 single variable condensers  
.0005 mfd.

2 Variable condenser dials marked  
0 to 100 or 0 to 180.

1 Clix plug.

3 Clix sockets.

S1 Single pole double throw switch.

C3 .001 mfd. fixed condenser.

1 Pair of high sensitivity earphones.

1 3-in. dia. × 8-in. former.

2oz of both 28 and 32 S.W.G.  
double cotton covered wire to  
make these 4 coils.

1 Permanent crystal detector.

In use, the plug should be tried in each of the three sockets to find the point which gives the best results. The switch is used as a wave band change switch.

## 12. Ultra Sensitive All Wave Receiver.

The receiver shown in Fig. 11 is for long distance reception. It is a novel circuit and, though apparently complicated in construction, it is really very simple to assemble with the minimum of tools and labour.

It will be seen from the circuit diagram that there are two banks of sockets, five black and six red. When using this set the appropriate black and red plugs should be inserted in whichever of the similar coloured sockets give the best results. The coil is quite easy to construct and consists of a primary winding which is inserted at the earth end of the secondary winding. For the medium wave band, the secondary winding L2 consists of 54 turns of 20 S.W.G. enamelled or cotton covered wire. This coil has four taps in addition to the starting point and the end connection, and these taps are taken at six turns, 14 turns, 27 turns and 40 turns from the earth end. The taps are taken out and a connection is made to an appropriate socket, as shown in the diagram.

The coil is wound on a 3-in. diameter former which may be a paper tube, bakelite, paxolin or perspex, and spacing is approximately 17 turns to the inch.

For short wave work down to about 30 metres, L2, the secondary coil, will consist of the same diameter former wound with 15 turns of the same gauge wire, the four taps being taken at 3, 6, 9 and 12 turns from the earth end.

L1, the primary coil, is used for both wave bands and consists of 11 turns of similar gauge wire to that used for L2, wound on a 2-in. × 1-in. former, the winding to be spaced the same as L2. The coil is then inserted at the earth end of whichever secondary coil L2 is being used.

The crystal detector may be one of the semi-permanent types freely available to-day; the old-fashioned cat's whisker pattern; or one of the silicon permanent detectors which are sold by many surplus dealers.

The 'phones should be of a standard type 4,000 ohms impedance although 'phones of other values will probably operate quite satisfactorily with this powerful receiver. It should, however, be stressed that the better the headphones used, the more satisfactory the reception.

Coils for other wave bands may be experimentally designed by the constructor, remembering that four tappings are advisable for the secondary coil L2.

A long aerial is very desirable with this receiver, placed as high as possible. It is recommended that a minimum length of 70-ft. be allowed, to include the aerial and lead-in.

The values of the components are shown in the following components list. The constructor should experience no difficulty in obtaining excellent results from this cleverly designed receiver.

C1 .0005 variable condenser.

C2 .002 fixed condenser.

1 semi-permanent crystal detector.

1 coil former 3-in. dia. × 4½-in.

1 coil former 2-in. dia. × 1-in.

½ lb. 20 S.W.G. enamelled or DCC  
copper wire.

6 red wander plug sockets.

6 black wander plug sockets.

1 red and 1 black wander plug.

Headphones, terminals, connecting wire



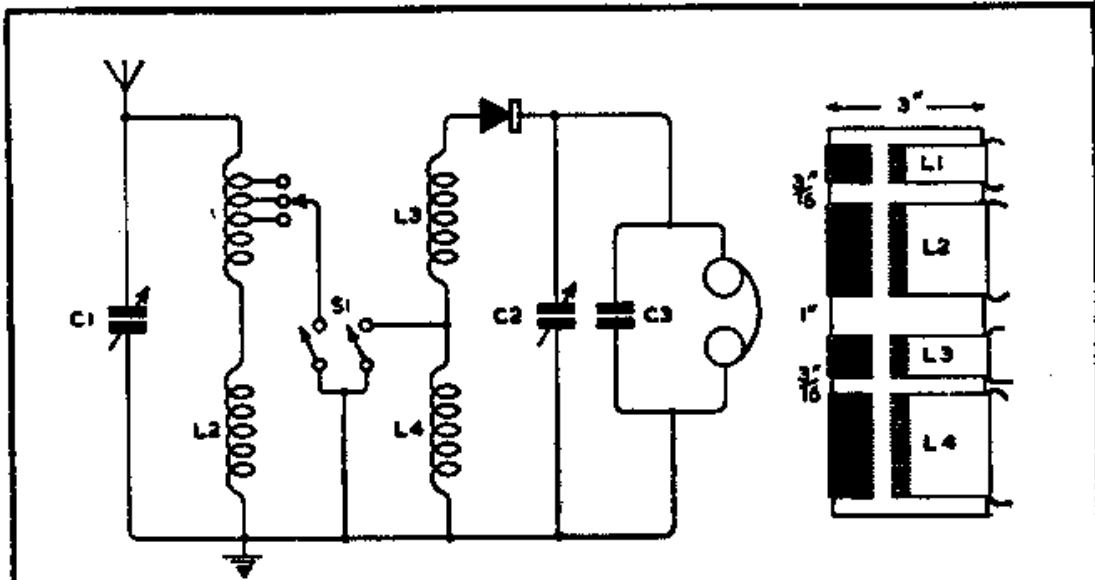

FIG. 10 MEDIUM AND LONG-WAVE CRYSTAL RECEIVER

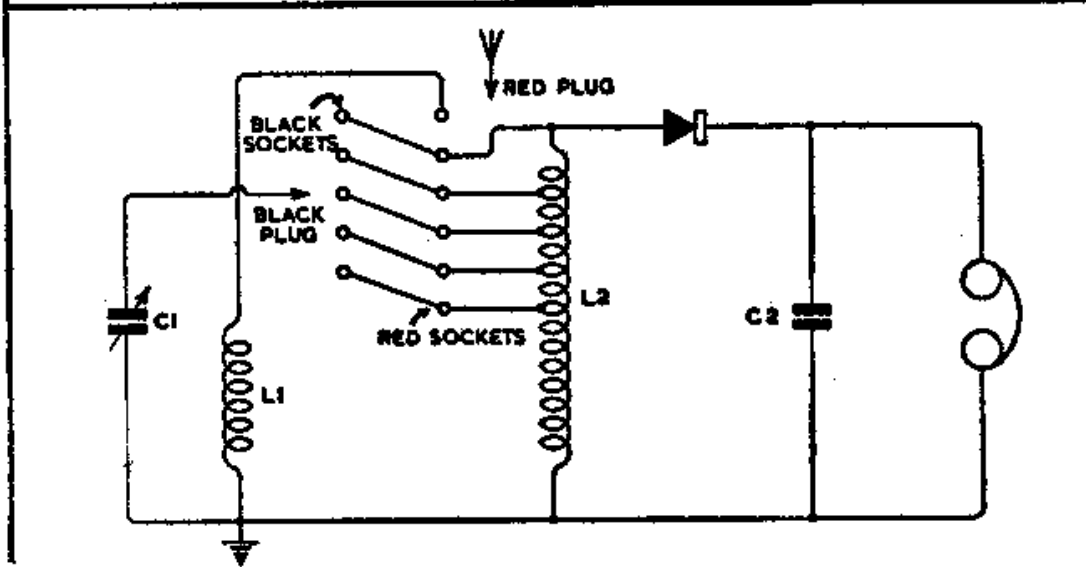

FIG. 11 ULTRA-SENSITIVE ALL-WAVE CRYSTAL RECEIVER

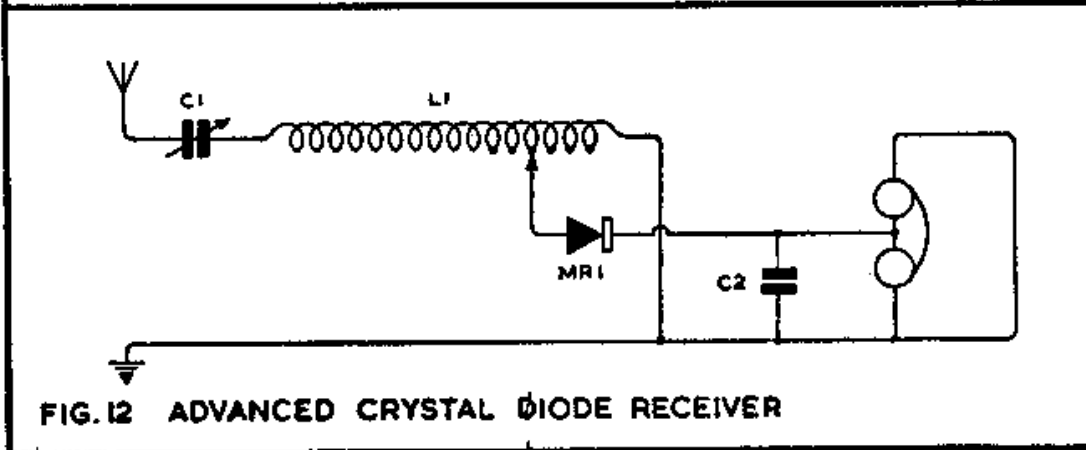

FIG. 12 ADVANCED CRYSTAL DIODE RECEIVER

### 13. An Advanced Crystal Diode Receiver.

The modern crystal diode of the radar type does not require any adjustment and thus has a distinct advantage over the ordinary crystal detector which needs delicate adjustment—even the semi-permanent type.

Such crystals are now obtainable on both the regular and the surplus markets, and a popular type is the B.T.H. CS7A silicon crystal (also coded as CV 253).

A rather different circuit from the usual crystal set arrangement is needed to suit the characteristics of a crystal diode. The diode must be tapped on to the tuning coil, and it is found that the tuning circuit itself gives best results if a series-tuned acceptor circuit is used. The circuit of a radar crystal receiver is shown in Fig. 12. The type of aerial used with this circuit has a very great bearing on the behaviour of the receiver for, in effect, the tuned circuit, with a series resistance equivalent to the reflected crystal load resistance, is in series with the capacitance of the aerial to earth and the aerial's effective series resistance.

At resonance—when the combination is tuned to any particular signal—the inductance resonates with the capacitances of the tuning condenser and the aerial in series, and the final effect is that the reflected load of the crystal, in series with the coil's R.F. resistance, is paralleled across the aerial's series resistance.

For maximum power transfer, the crystal load resistance must be made equal to the sum of the aerial series resistance and the coil R.F. resistance, and so the method in which the crystal is tapped into the tuning coil, and the exact capacitance required to tune the receiver to any required signal, must depend to a very great extent on the aerial itself.

At the same time the crystal resistance varies with the signal strength, the resistance being high for weak signals and dropping by as much as 50 per cent. and more for strong signals, so that this effect also has a bearing on the correct coil tap. The output impedance of the crystal also varies similarly, affecting the matching of the headphones into the crystal diode, and so for any set of conditions, the receiver requires to be matched up to both the aerial and the signal being received for best results. This would mean a series of coil taps and (theoretically, not practically) a matching transformer between the diode and the headphones; but in practice it will be found that a receiver using standard parts can be built up to give very good results under various conditions.

It has been shown already that the tuning of the receiver depends to a great extent on the characteristics of the aerial, and while a .0005 mfd. variable capacitor is shown in Fig. 12 as the tuner, the constructor must be prepared to experiment with different capacitance values until the required station is tuned in. The range of reception given by the receiver is quite good, if a really long and high aerial, and a good earth connection, are used; but no more than the local station signal can be expected, and the tuning therefore must be adjusted to suit the station frequency.

It must be mentioned that the headphones are shown parallel connected. High resistance headphones of the 4,000 ohm type must be used, and if two of these are connected in parallel rather than in the more usual series method, they will provide a roughly accurate match to the crystal. If more than one pair of headphones are to be connected in, then the pairs of headphones may be left series connected in the usual manner, the sets of headphones being connected in parallel.

The capacitor across the headphone terminals completes the crystal R.F. circuit, and any value between about 0.001 and 0.005 mfd. will serve. The higher capacitance will, of course, by-pass some of the higher audio frequencies, so

that if good steady reception is obtained some experiment with this condenser is also worth while.

C1, .0005 mfd. variable condenser.

M.R.1 CV 253 Crystal diode.

C2, .005 mfd. fixed condenser.

Coil former  $1\frac{1}{4}$ -in. dia.  $\times$   $4\frac{1}{4}$ -in.

4oz. 26 S.W.G. enamelled copper wire.

Coil details are as follows: 150 turns of 26 S.W.G. tapped at 20, 25, 30, 35, 40 and 45 turns from the earth end. At each tapping-point the wire should be twisted up into a loop and the winding then continued without breaking the wire; when the coil is completed and the ends anchored the tapping loops can be bared.

# BERNARDS RADIO BOOKS

No.		Price
56.	Radio Aerial Handbook ... ..	2/6
57.	Ultra-Shortwave Handbook ... ..	2/6
58.	Radio Hints Manual ... ..	2/6
64.	Sound Equipment Manual ... ..	2/6
68.	Frequency Modulation Receivers' Manual ... ..	2/6
73.	Radio Test Equipment Manual ... ..	2/6
83.	Radio Instruments and their Construction ... ..	2/6
96.	Crystal Set Construction ... ..	1/-
99.	One Valve Receivers ... ..	1/6
100.	A Comprehensive Radio Valve Guide, Book 1 ... ..	5/-
103.	"Radiofolder" A. The Master Colour Code Index for Radio and T.V. ... ..	1/6
104.	Three Valve Receivers ... ..	1/6
107.	Four Valve Circuits ... ..	1/6
108.	Five Valve Circuits ... ..	2/6
121.	A Comprehensive Radio Valve Guide, Book 2 ... ..	5/-
123.	"Radiofolder" F. The Beginners' Push-Pull Amplifier ... ..	1/6
126.	Boys' Book of Crystal Sets and Simple Circuits ... ..	2/6
129.	Universal Gram Motor Speed Indicator ... ..	1/-
134.	F.M. Tuner Construction ... ..	2/6
135.	All Dry Battery Portable Construction ... ..	2/6
138.	How to Make F.M. and T.V. Aerials, Bands 1, 2 and 3 ... ..	2/6
141.	Radio Servicing for Amateurs ... ..	3/6
143.	A Comprehensive Radio Valve Guide, Book 3 ... ..	5/-
145.	Handbook of AM/FM Circuits and Components ... ..	2/-
146.	High Fidelity Loudspeaker Enclosures ... ..	5/-
147.	Practical Tape Recording Handbook ... ..	5/-
148.	Practical Transistor Receivers, Book 1 ... ..	5/-
149.	Practical Stereo Handbook ... ..	3/6
150.	Practical Radio Inside Out ... ..	3/6
151.	Transistor Superhet Receivers ... ..	7/6
155.	Portable Transistor Radio and Radiogram ... ..	2/6
156.	Transistor Circuits Manual, No. 1 ... ..	2/6
157.	A Comprehensive Radio Valve Guide, Book 4 ... ..	5/-
158.	Radio, Television, Industrial Tubes, Semiconductor and Diodes Equivalents Handbook (206 pages) ... ..	9/6
159.	Realistic High Fidelity ... ..	5/-
160.	Coil Design and Construction Manual ... ..	5/-
161.	Radio, Television and Electronics Data Manual ... ..	3/6
162.	High Fidelity Stereo Gramophone ... ..	5/-
163.	Transistor Circuits Manual, No. 2 ... ..	2/6
164.	High Fidelity Tape Recorder for the Home Constructor ... ..	2/6
165.	Hartley on Hi-Fi, Book 1, Radio Tuners ... ..	5/-
166.	Public Address Systems ... ..	2/6
167.	Transistor Circuits Manual, No. 3 ... ..	2/6
168.	Transistor Circuits Manual, No. 4 ... ..	2/6
169.	Hi-Fi Transistor F.M. Tuner for the Home Constructor ... ..	3/6
170.	Transistor Circuits for Radio Controlled Models ... ..	7/6
171.	Super Sensitive Transistorised Pocket Set Construction ... ..	3/6
172.	International Radio Stations List ... ..	2/6
173.	Practical Transistor Audio Amplifiers... ..	3/6
174.	Transistor Subminiature Receivers Handbook ... ..	5/-
175.	Transistorised Test Equipment and Servicing Manual ... ..	3/6
176.	Transistor Audio Amplifiers Manual ... ..	6/-
177.	Modern Transistor Circuits for Beginners ... ..	7/6
178.	Comprehensive Radio Valve Guide, Book 5 ... ..	6/-
179.	Transistor Circuits Manual No. 5 ... ..	5/-
180.	British Semiconductor Survey ... ..	15/-
181.	22 Tested Circuits Using Micro Alloy Transistors ... ..	5/-
182.	"At A Glance" Radio Valve & T.V. Tube Equivalents... ..	3/6
183.	How to Receive Foreign T.V. Programmes on your Television Set by simple Modifications ... ..	5/-
	Resistor Colour Code Calculator ... ..	1/6
	Engineers' Reference Tables ... ..	1/6
	International Radio Tube Encyclopaedia—3rd Edition ... ..	63/-



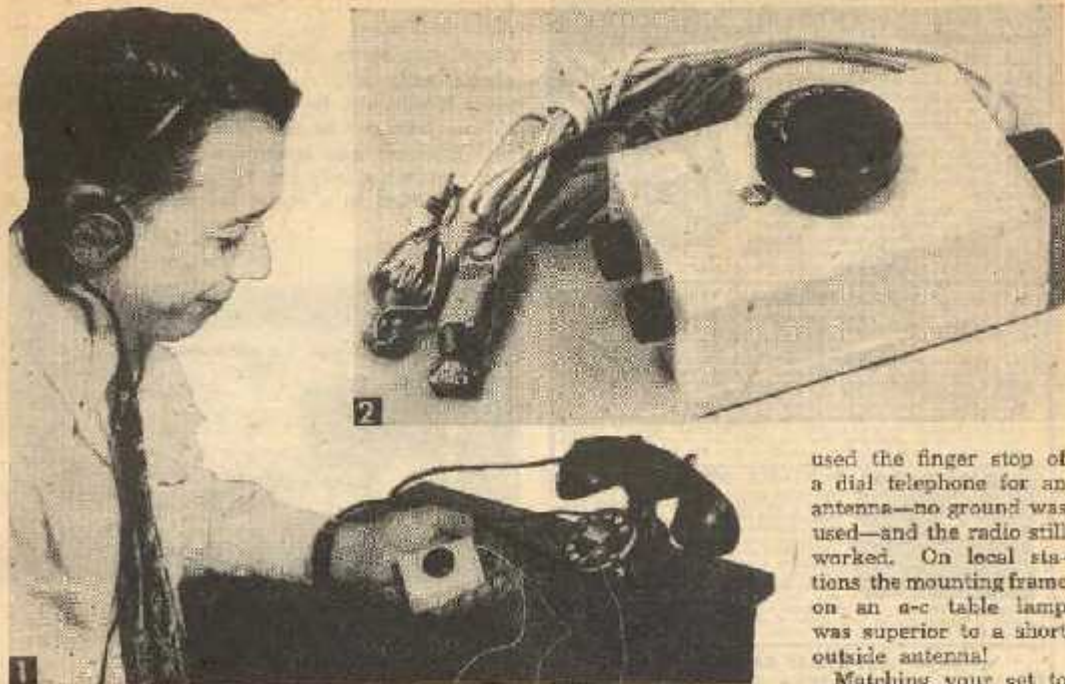

## Super-Sensitive Vest-pocket Crystal Radio

A "high-Q" antenna coil makes this set a real performer

By T. A. BLANCHARD  
Radio Editor

**F**AR from being a throw-back to the days when radio coils were wound on oatmeal boxes with doorbell wire, this tiny crystal set separates stations—without batteries or a complex circuit.

Aside from selectivity good crystal set results depend upon antenna and ground. For long-distance reception, use as long and high an antenna as possible. Where space is at a premium, the antenna may be installed in X fashion (Fig. 4). Use a cold-water pipe as ground, or in rural areas, a well pump pipe. However, we

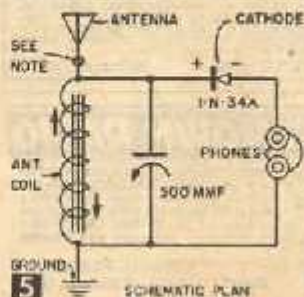
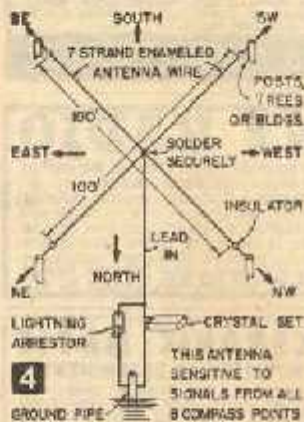
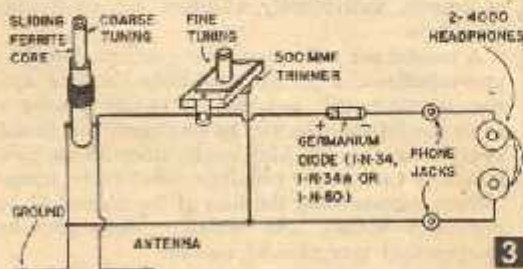

used the finger stop of a dial telephone for an antenna—no ground was used—and the radio still worked. On local stations the mounting frame on an a-c table lamp was superior to a short outside antenna!

Matching your set to the particular broadcast frequency heightens crystal reception. Don't hesitate to try all kinds of objects for picking up a signal. One good antenna

was a bed spring with the metal frame of a bed lamp as ground. Another good match were two grounds at different potentials—one a water pipe, the other, a copper line to a propane tank.

The final requisite for good reception is a pair of sensitive headphones. These should be magnetic headphones of 2000 or 4000 ohms resistance. Do not go on labels alone. Unscrew the caps from any headphones you plan

**NOTE:** Insert 100 to 500 mfd. micro condenser to tune in 1800 to 1000kc. stations when long outdoor antenna is used.

to purchase. If the metal diaphragms drop off, don't buy them. In good headphones the metal diaphragm sticks to the magnets. Any headphone with only a single coil inside the ear piece should also be passed up as unsatisfactory.

Now let's get to building the pocket crystal set. This set was assembled in a small plastic box measuring only 3 x 1 $\frac{3}{8}$  x 1 $\frac{1}{8}$  in. but it may be assembled in a metal or wood container of

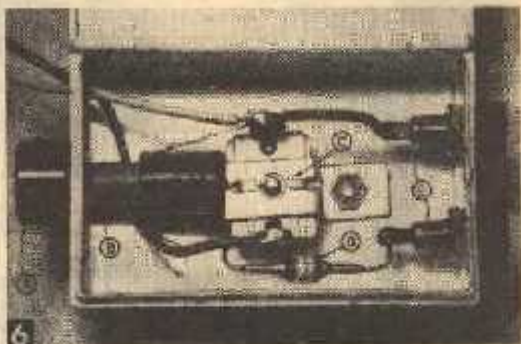

Arrangement of components inside plastic or metal case. (A) coarse tuning knob, (B) ferrite core antenna coil, (C) fine tuning trimmer capacitor, (D) germanium diode and (E) phone jacks.

any convenient size. Fig. 6 shows the actual assembly and if you follow connections, the case size is not important.

A ferrite slug-tuned type antenna coil is the reason this set is so highly selective. Sliding the ferrite core in and out of the coil accomplishes the same result as complicated wave-traps. Fine tuning is accomplished with the trimmer capacitor. Stations near the top of the dial (550 kc.) are tuned-in with the coil slug pushed in. Sta-

#### MATERIALS LIST—VESTPOCKET RADIO

- 1—Small plastic box (Safety razor case, cigaret box, etc.)
- 1—Progressive wound antenna coil with adjustable ferrite core (Miller, Stanwyck)
- 1—Misc trimmer condenser (500mmf or 600mmf max. capacity)
- 1—Germanium crystal diode (1N34, 1N34A or 1N60)
- 2—Earphone tip jacks (Insulated or non-insulated type)
- 2—PacWax spring clips
- 2—3-ft. lengths plastic hook-up wire (stranded)
- 1—Pair sensitive magnetic headphones (2000 to 4000 ohm res.)

Kits including all necessary parts for building this vestpocket crystal radio may be obtained for \$2.98 (postpaid) from ElectroMite, P. O. Box 636, Springfield, Conn.

tions near the bottom of the dial (1600 kc.) are tuned-in with slug pulled out. Both controls are, of course, individually adjusted for maximum reception.

A crystal set with these two great modern improvements—the germanium diode detector and the ferrite-tuned antenna coil—can fascinate even the fellow who thinks he's seen and heard everything. Our big kick comes from seeing how much we can get for free from two nearby transmitters representing the hub of the biggest U. S. networks—WCBS and WNBC. Both provide loudspeaker reception at no cost!



I've always wanted to make a radio using a variometer. In the old radio books that I read as a kid, variometers were pictured as two coils connected in series, one inside the other. The inner coil could be rotated and would either cancel or add to the inductance of the outer coil, depending on how it was oriented. Variometers were used to tune radios before variable capacitors became common. Unfortunately, I couldn't figure out an easy way to build one.

The problem must have stuck in my subconscious, because forty years later I realized that the coils didn't have to rotate; one coil could be slid over another. When I realized that, I put together the Variometer Radio described in this article in a couple of hours, and it works great! Even though it doesn't use a variable capacitor, it can still be tuned "on the nose" to stations in the broadcast band.

**The Variometer Principle.** In the original variometer design, when the inner coil is rotated to a 90-degree position with respect to the outer coil, the mutual inductance of the coils is at its minimum. For the mutual inductance of the coils to be at its maximum, the coils have to be aligned.

Figure 1 is a schematic diagram of how the variometer principle was adapted to a linear design in the project. Three coils, L1-L3, are connected in series; L1 and L3 are fixed, while L2 can be slid over them. Unlike in the

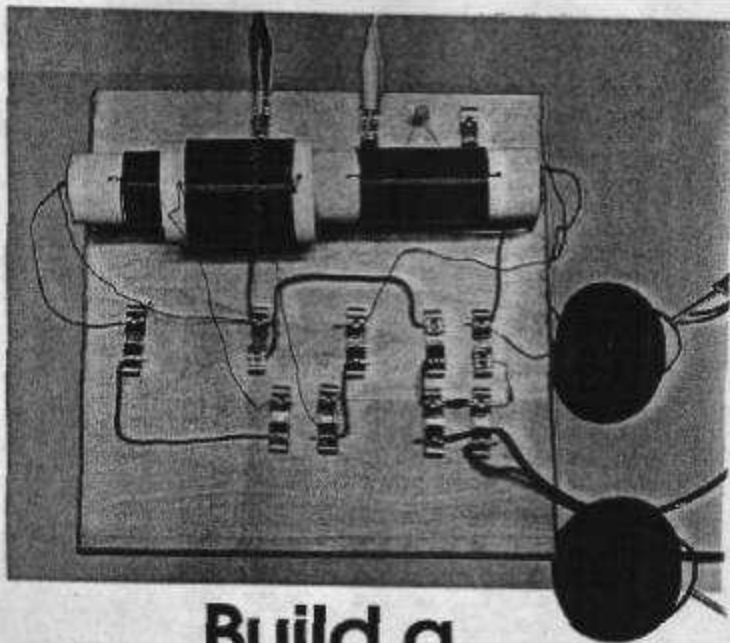

# Build a Variometer Radio

*A new version of a classic design.*

BY LARRY LISLE

original variometer, it is the outer coil that moves over the inner coils. As L2 is moved over L1, their mutual inductance is increased to the maximum. But when L2 is moved over L3, their inductances cancel out because L3 is connected backwards (with respect to L2).

**The Circuit.** The schematic of the complete Variometer Radio is shown in Fig. 2. An antenna can be connected to the Radio through either of two points labeled ANT: either directly to the circuit or through a 100-pF capacitor. The ground connection can be made at any of the points marked GND. There is a reason for the preceding options: By varying the antenna capacitance, the ground connection, and the position of the sliding coil, the entire AM broadcast band can be tuned.

Depending on the antenna and ground connections, it might be necessary to add a small capacitor, C3, at

the point indicated in the schematic. If so, experiment with values between 25 and 200 pF (separately or in parallel) to find which gives the best result. If you build the Variometer using Farnestock clips (as explained later), adding the capacitor(s) after the Radio is built should be easy, if the need arises.

When a signal is selected by adjusting the antenna, ground connection, and position of L2, the signal is passed on to the diode-detector part of the circuit, composed of D1, which demodulates the signal. That signal then goes through bypass capacitor C2 to the earphones. Only high-impedance earphones should be used with the Variometer.

**Construction.** The two fixed coils of the Variometer, L1 and L3, are wound on an 8½-inch-long piece of 1-inch-diameter plastic pipe (its outer diameter is about 1¼ inches). Each coil is 2¼-inches long. The number of turns is

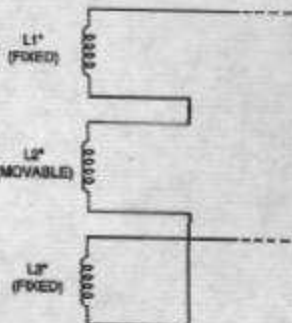

\*SEE TEXT

Fig. 1. This is the principle at work in the modern variometer. The middle coil, L2, can be slid over either of the other two. Because L1 and L3 are connected in opposite directions, the inductance of L2 will either add or cancel when it is moved over the other coils.

not critical, but in the author's prototype, 86 tightly wound turns of number-22 enameled wire were used. When winding the coils, make sure you start at a point that will allow them to be placed 2 inches apart on the pipe. Drill holes in the pipe and run the leads of the coils out the end of the pipe that is closest to each.

The movable coil, L2, is wound on a piece of 1½-inch plastic pipe (its outer diameter is about 1¼ inches). The winding is 2 inches long. Like L1 and L3, the actual number of windings of this coil are not critical, as long as the winding is approximately the right length. However, in the author's prototype, 74 tightly wound turns of number-22 enameled wire were used.

One final note on winding the coils: Plastic pipe was used in the author's prototype for durability. An alternative to that is to use cardboard tubes, especially if you only plan on experimenting with the Variometer Radio.

To support the smaller plastic pipe that contains L1 and L3, get an 8½-inch-long piece of 1-inch dowel rod. Using sandpaper or a knife, slightly flatten one side of the dowel. Then, insert the dowel rod into the pipe, and orient the flattened side of the rod so that the wires can run along it with some clearance. Mount the assembly

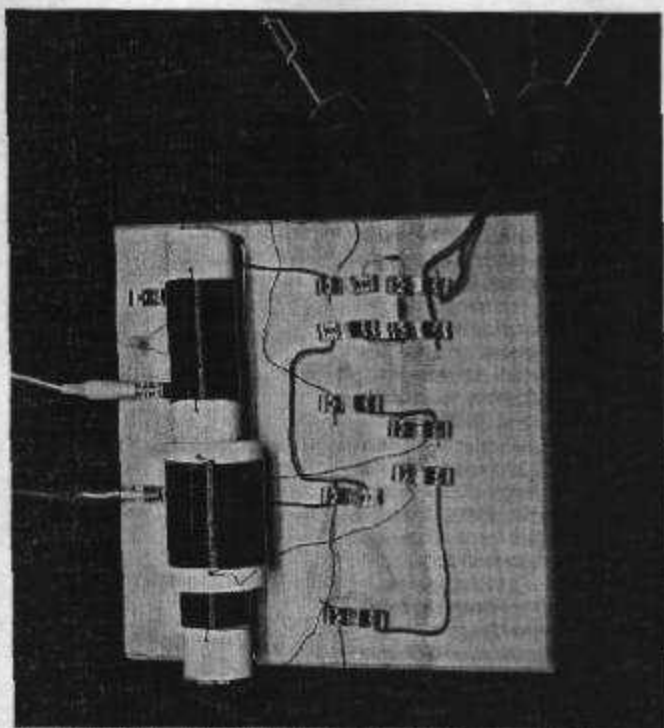

Here's the author's completed radio. For simplicity, it is laid out much like the schematic shown in Fig. 2.

on a wooden baseboard (approximately 9 inches square) using a couple of corner brackets.

To make it easier to change ground and antenna connections, the prototype was built using Fahnestock clips. When laying out the placement of the parts on the baseboard, make sure to include adequate connection points for the possible use of capacitor C3 in the circuit. If you can't get Fahnestock clips, don't worry, an al-

ternative way to build the Radio is to use brass wood screws for the common points and simply wrap the wire around them.

**Other Uses.** Just by assembling your Variometer Radio and experimenting with tuning different stations, you might not realize that the variometer principle can be used in other applications as well. Some of those include uses in antenna loading coils, couplers, or matching devices.

Also, taping on one coil could give coarse adjustment, while a sliding coil can be used for fine tuning. With variable capacitors suitable for medium- or high-power ham transmitters becoming expensive and hard to find, the variometer principle might also find a use in the final output stage on the low-frequency bands.

The Variometer Radio is a modern version of an idea from radio past that's fun to play with in radio present. However, as you can see, the variometer principle might also become important in radio future. ■

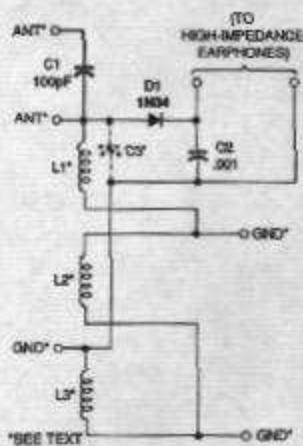

Fig. 2. Here is the modern variometer principle at use in a complete Variometer Radio. Even if you've never built a radio before, you can build this crystal set; the parts cost is low, and the coil windings are not critical.

#### PARTS LIST FOR THE VARIOMETER RADIO

- D1—1N34 germanium diode
- C1—100 pF, ceramic-disc
- C2—0.001- $\mu$ F, ceramic-disc
- C3—Optional, see text
- L1, L3—See text
- L2—See text

Baseboard (about 9 inches square), 1-inch-diameter dowel rod, 2 pieces of plastic pipe (see text), Fahnestock clips, corner brackets, screws, wire, hardware, etc.





The Set Designed, Constructed and Described by the "P.W." Technical Staff.

NOW that 5 X X is transmitting a morning programme, it is a great advantage for those listeners who are situated within range of that station to be able to switch over to the long waves. At any point within 100 miles of the B.B.C.'s high-power station, quite good signals are receivable from Daventry upon 1,600 metres, provided, of course, that an ordinarily efficient outdoor aerial is employed.

Later in the day, when the local station is transmitting, in most districts these signals will be stronger than the Daventry ones. But, nevertheless, it is desirable to be able to change over to 1,600 metres, in order that the alternative programmes afforded by 5 X X are available, when the local station is closed down.

**Few Parts Necessary.**

For this reason there has recently been a great demand for an easily made, easily handled crystal receiver, which is capable of tuning both to the local station (low waves), and also up to 1,600 metres, for the reception of Daventry.

LIST OF COMPONENTS.		s.	d.
1 Panel, 6x6x1/2 in. with box		7	0
1 Lamplugh '0005 variable condenser		17	6
1 "Gripheo" permanent crystal detector		2	6
2 Coil formers			6
1/2 lb. 26 S.W.G. D.C.C. wire		1	3
1 Bretwood single coil holder		1	3
Screws, transfers, etc.		1	6

Most readers of this journal are already aware of the advantages of "Ultra" tuning. But, as a great many new readers have recently asked for another crystal set constructed upon these lines, the set shown in the photographs has been made. It is quite an easy little receiver to construct, employing home-made basket coils. The full list of the components necessary to build the set is given upon this page.

It will be seen that the parts utilised are few in number and not at all expensive. From the photographs given here it will be seen that the receiver is contained in a neat box with a flat ebonite panel. The aerial and earth terminals are to the left of the receiver, and opposite are placed the two terminals for the telephone connections.

The tuning condenser and loading coil sockets are placed centrally, the latter having a short plug-in position when receiving upon short waves. When receiving Daventry it is necessary to remove the shorting plug, and to plug in a 150-turn tuning coil.

The views of the underside of the panel show that there is nothing complicated about the set, the only point which might puzzle a novice being the fact that the aerial coil is separated into two half coils (the small basket coils seen on

either side of the set). The connections are so made that these two small basket coils are united in effect into one aerial coil, working upon the Ultra principle.

In these days, when most listeners take an interest in the circuit which they use, it will be worth while to describe in a few words the underlying idea which has been so successful when embodied in the various "P.W." Ultra circuits. It is well known that in all crystal receivers there are two distinct circuits, the "detector circuits" and the "oscillatory circuit." The crystal and the telephone constitute the main part of the former, whilst the oscillatory circuit consists of the aerial itself, a tuning condenser and coil, and the earth lead.

The chief difference in crystal circuits lies in the method of coupling the oscillatory circuit to the detector. There are three main methods in which this can be affected, known respectively as "direct coupling," "inductive" (or "magnetic") "coupling," and "auto-coupling."

**Direct and Loose Coupling.**

The commonest method is by direct coupling. This consists of connecting the aerial and earth leads direct to a tuned circuit, across which the detecting apparatus (phones and crystal) is placed. This method has several disadvantages, but it is extremely simple, which to a large degree explains its popularity.

Another plan which is often adopted is to lead the aerial and earth connections to one "primary" coil, which is entirely separated from the circuit to which the detector is connected. If the tuning coil in the latter ("secondary") is placed near the aerial coil, a certain amount of energy will be transferred magnetically across the space between them.

This method is therefore called magnetic or inductive coupling, but it has the

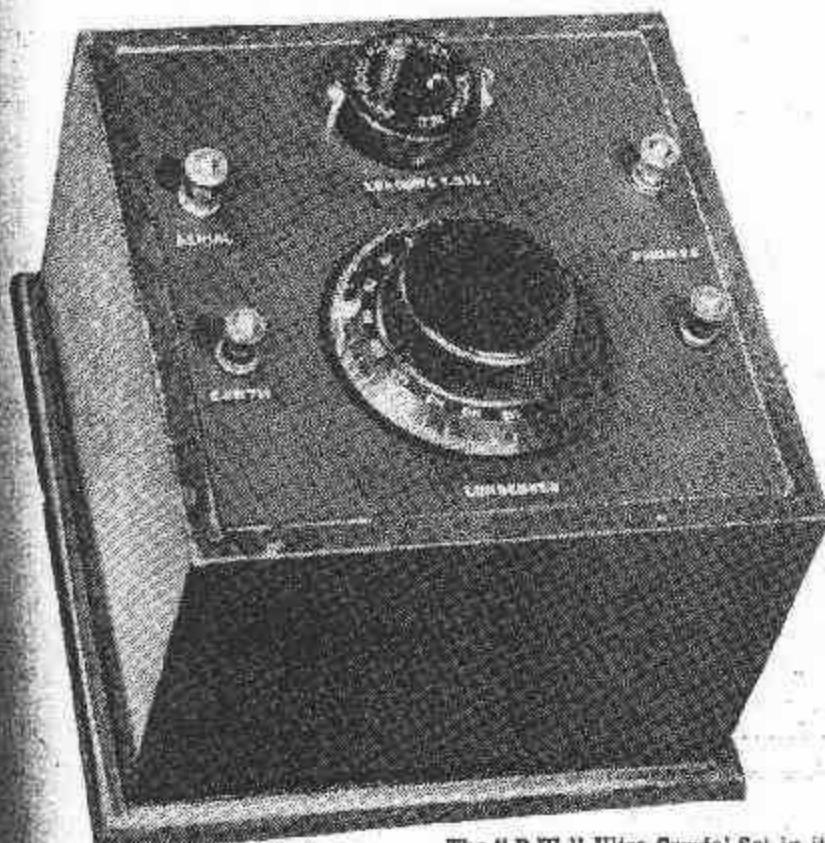

The "P.W." Ultra Crystal Set in its completed form but with loading coil removed.

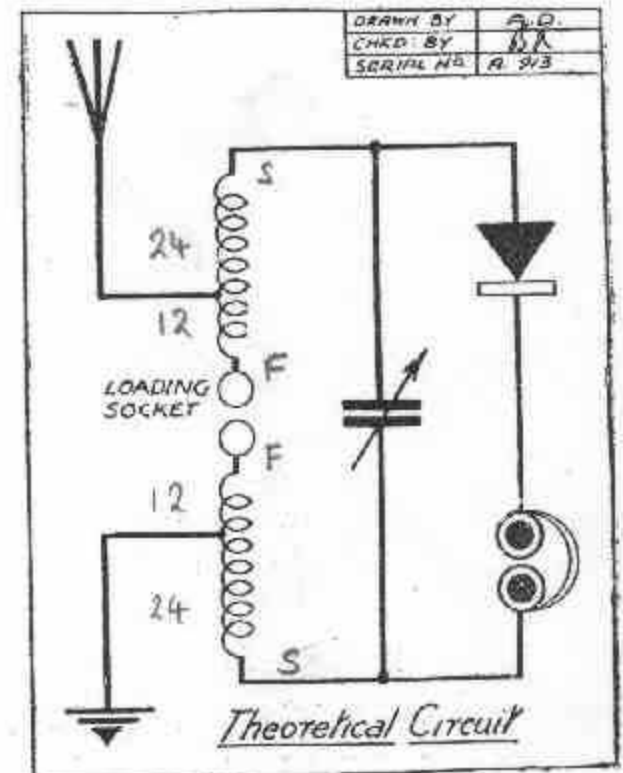

disadvantage of requiring two tuned circuits, one attached to the detector, and the other attached to (and partly consisting of) aerial and earth. Two separate tuning controls are necessary, so in order to obviate this disadvantage, the method known as auto-coupling was evolved.

In auto-coupling there are still the two essential circuits, but part of the set is (Continued on next page.)



A "P.W." ULTRA SET.

(Continued from previous page.)

common to both of them. This will be seen from the diagram on the previous page. The aerial-earth circuit consists of the aerial lead, 24 turns of the Ultra coil, and the earth lead. (A shorting plug is inserted midway between the earth and aerial leads, and a loading coil is plugged in here when Daventry is being received.)

Across the two free ends of the coil is placed a tuning condenser, and in parallel with it are the crystal and telephones. When the local station is broadcasting part of the energy flows through the mid-portion of the Ultra coil, and if the main circuit is tuned to the incoming signals, strong impulses are set up in it, which are rectified by the crystal and heard in the 'phones.

Winding the Coils.

These conditions would obtain if the aerial were placed at the lower end of the tuned circuit shown on the diagram, leaving the earth lead as at present connected. But the advantage of the Ultra system lies in the fact that the aerial and earth leads are connected at equal distances from the centre point of the coil, so that the auto-coupling is "balanced."

The first step is to wind the two small basket coils. The former upon which they are made has a diameter of 3 1/2 in. with a centre of 1 1/2 in. Thirty-six turns of No. 26 S.W.G. are wound upon each. When the

24th turn is reached in both cases, a loop is made and left for tapping.

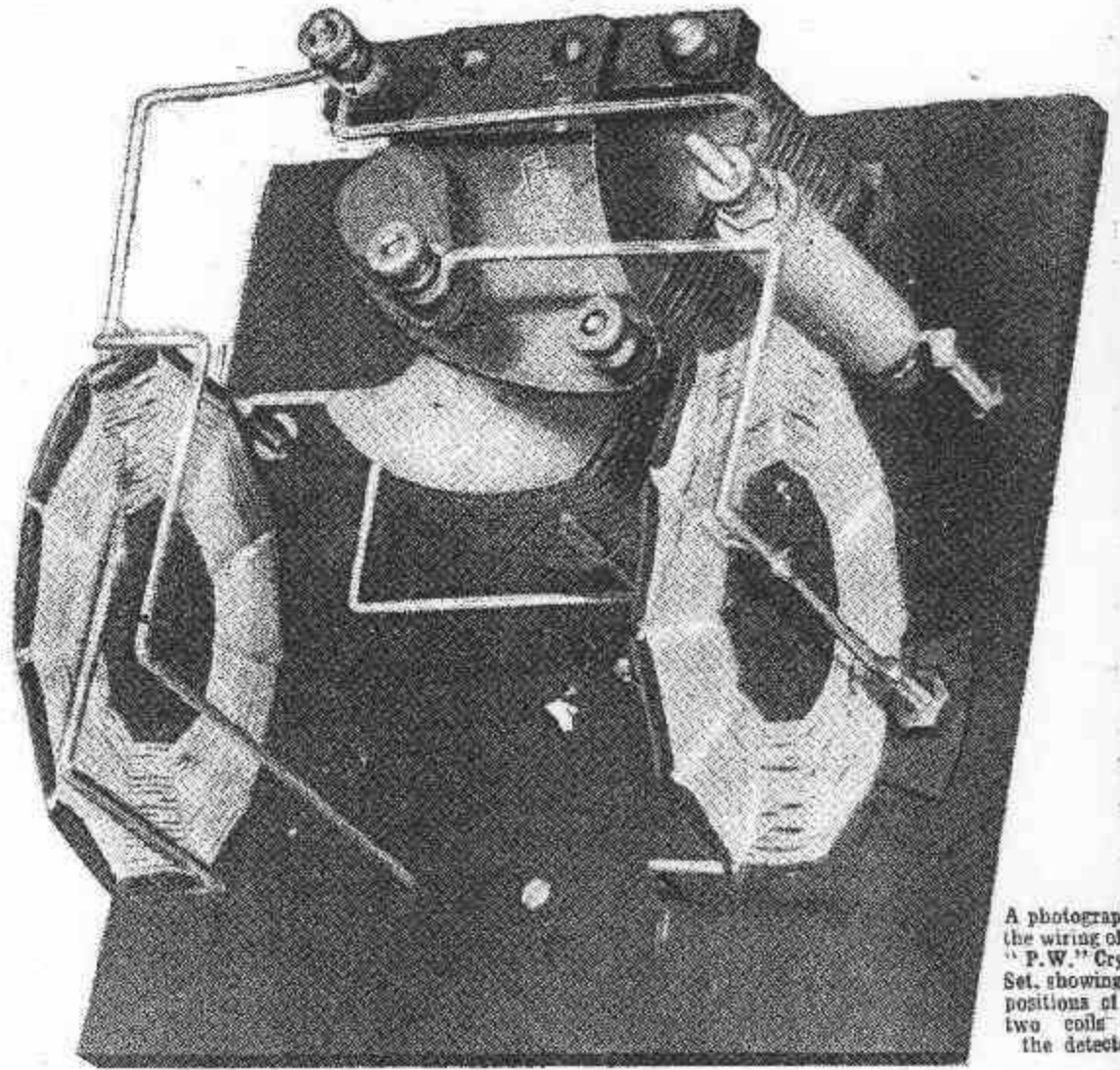

A photograph of the wiring of the "P.W." Crystal Set, showing the positions of the two coils and the detector.

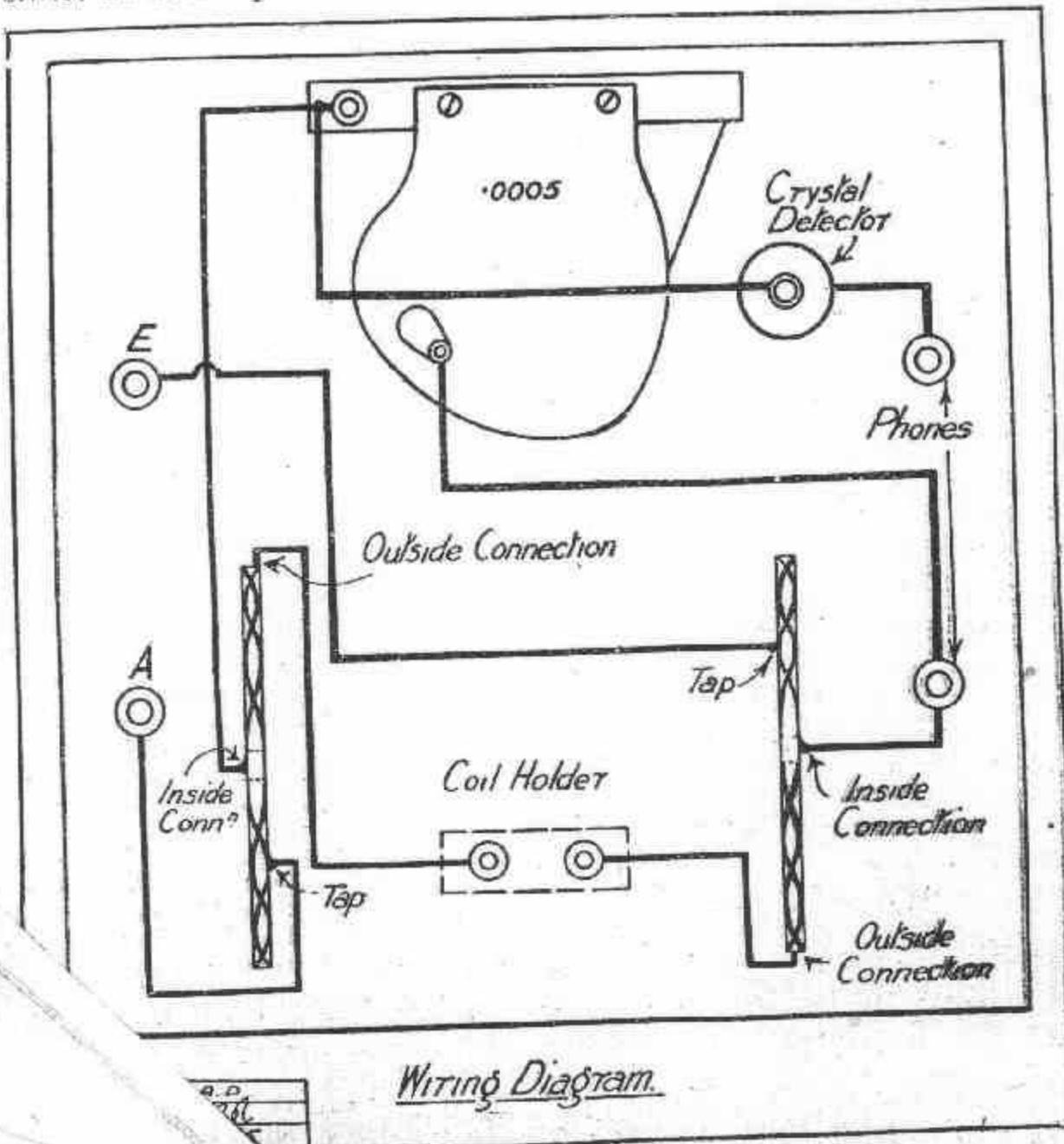

The 36 turns will leave a space of about 1/2 in. on the outside of the former, so this should be trimmed off with a pair of scissors, except in the case of one section. This is left full length, a hole is made in the centre of it, and, when placed over the shank of the aerial or top 'phone terminal, and bent at right angles, this will hold the coil to the panel.

The drilling of the panel is quite an easy operation, and is carried out in accordance with the drilling diagram on the next page. It will be seen from the photographs that it is not necessary to mount the crystal detector separately, as the little component used in this instance can be fixed securely by its connection to the terminals and to the condenser.

Hints on Operation.

The wiring diagram on this page is self-explanatory, but do not forget when making the connections that the secret of success in the crystal set is good contact. Wherever possible the joints should be soldered, as if they are in any degree inefficient a loss of signal strength will result.

When the wiring has been completed it can be checked over from the list of point-to-point connections, which is given on next page. Great care must be taken to keep the panel clean and free from brass dust, flux, etc.

As the set is such a simple and straightforward one, it is hardly necessary to give further details of operation, etc., but for the sake of the novice the method of connecting up will be briefly outlined. Aerial and earth leads are connected to their respective terminals, and if the local station is to be tuned in a shorting plug should be placed in the coil holder.

Adjust the crystal and vary the tuning condenser until signal strength is obtained. (Continued on next page.)



## A "P.W." ULTRA SET.

(Continued from previous page.)

To change over to the long waves all that is necessary is to remove the shorting plug from the coil holder and replace by a tuning coil having approximately 200 turns. Where a long aerial is employed 175 turns are sometimes better, but anything between

### POINT-TO-POINT CONNECTIONS.

Aerial terminal to tap of left-hand coil.  
Earth terminal to tap of right-hand coil.  
Inside connection of left-hand coil to fixed plates of .0005 variable condenser and to one side of crystal detector. Moving plates of variable condenser to inside connection of right-hand coil and one 'phone terminal. Other 'phone terminal to other side of crystal detector. The outside connections of the left and right-hand coils are taken respectively to the plug and socket of the coil holder.

150 and about 230 turns will generally do, the variation being automatically adjusted by altering the tuning condenser.

It may be as well to point out that any form of tuning coil will do for the loading coil, either basket coils or those of the fluolateral type being the most popular.

### The Loading Coil.

If desired, it may be a home-made basket coil, but this will be rather bulky. The best way to reduce its size as far as possible is to use "double winding." Instead of taking the wire in and out of every slot, it can be wound into alternate

slots, the resultant coil being thicker, but less fragile, than when the normal slot-winding is employed.

With the original set shown in the illustrations, good signals were obtained from Daventry's morning transmission, both in London itself and in the suburbs. Reception from 2 L O was clear and faultless, and any reader who gets similar results will be delighted with this simple but efficient receiver.

### Amplification.

There is no reason, if signals are good, why an L.F. amplifier having either one or more valves should not be added to the "P.W." Ultra Crystal Set in order to enable it to operate a loud speaker.

Unless the signals are really strong—such as those obtainable when the set is within five miles of a broadcasting station—the one-valve amplifier will not be sufficient to operate a loud speaker properly. Two valves, however, should enable this to be carried out up to 15 miles or so from a local main station or 80 miles or so from 5 X X.

Such amplification will not necessarily increase the range of reception of the set,

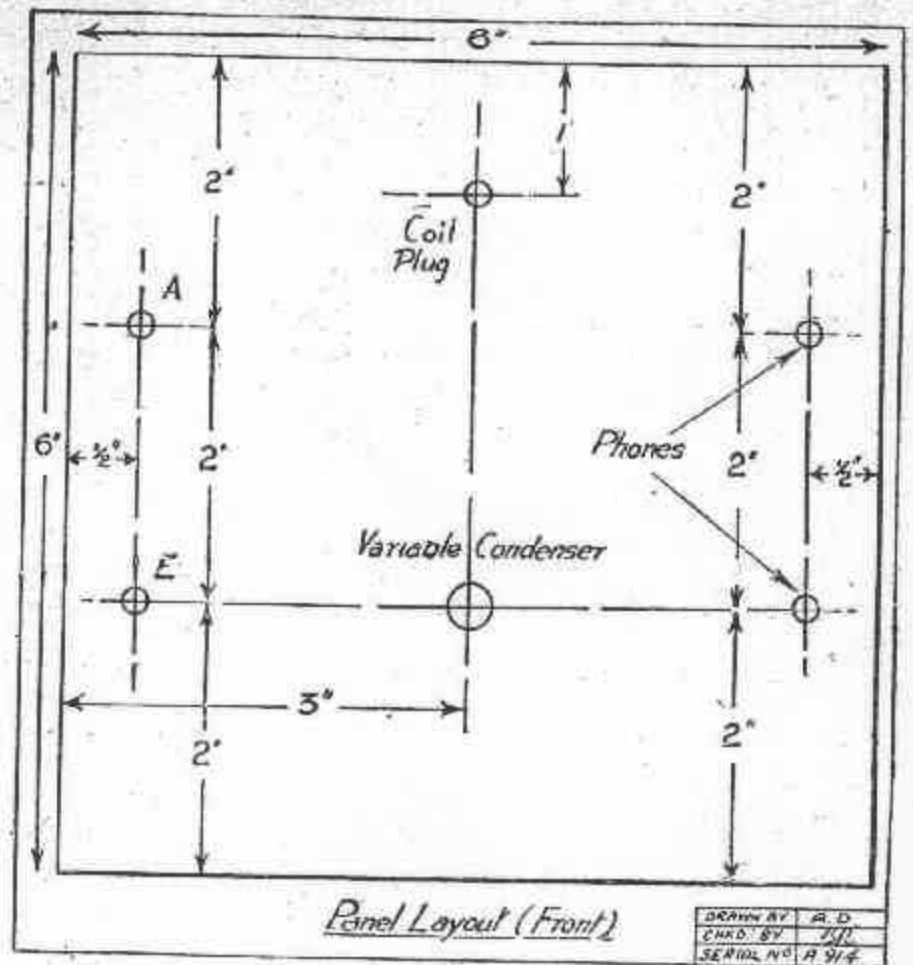

but can only be relied upon to increase the signal strength of broadcasting that is already audible.

## FAULTY COMPONENTS.

Too few wireless amateurs seem to realise that the whole success or failure of a wireless set depends upon its components, and if these are poor there is almost certainly bound to come a time when troubles will occur.

One of the main pieces of apparatus which can spoil the efficiency of the set is the fixed condenser. Recently the writer set himself the task of dissecting about two dozen fixed condensers of different makes, but according to the markings of the same capacity. Without going into details it is sufficient to say that out of the 24 only two were of the exact capacity stated. As a matter of fact, three of the cheap condensers were actually short-circuiting, which goes to prove how necessary it is to obtain apparatus of reliability.

Too great attention cannot be paid to such things as filament rheostats or resistances. Valves should never light up brightly as soon as the rheostats are the slightest bit "on," otherwise they are liable to burn out very quickly.

A rough-and-ready rule to discover the resistance required is to divide the valve makers figure for filament voltage by the figure for the filament current. Thus, if a valve takes 5 volt, and .65 amp., such as the Marconi R.5V, a filament rheostat of approximately 8 ohms max. will be required.

What is more important, however, is the fact that the filament rheostat, as well as having a resistance of 8 ohms, must have wire sufficiently thick to carry .65 amp., otherwise it will heat up and either offer a further slight resistance which, if receiving a distant station, might upset the working of the set or else fuse, scorch the panel, and possibly set something on fire.

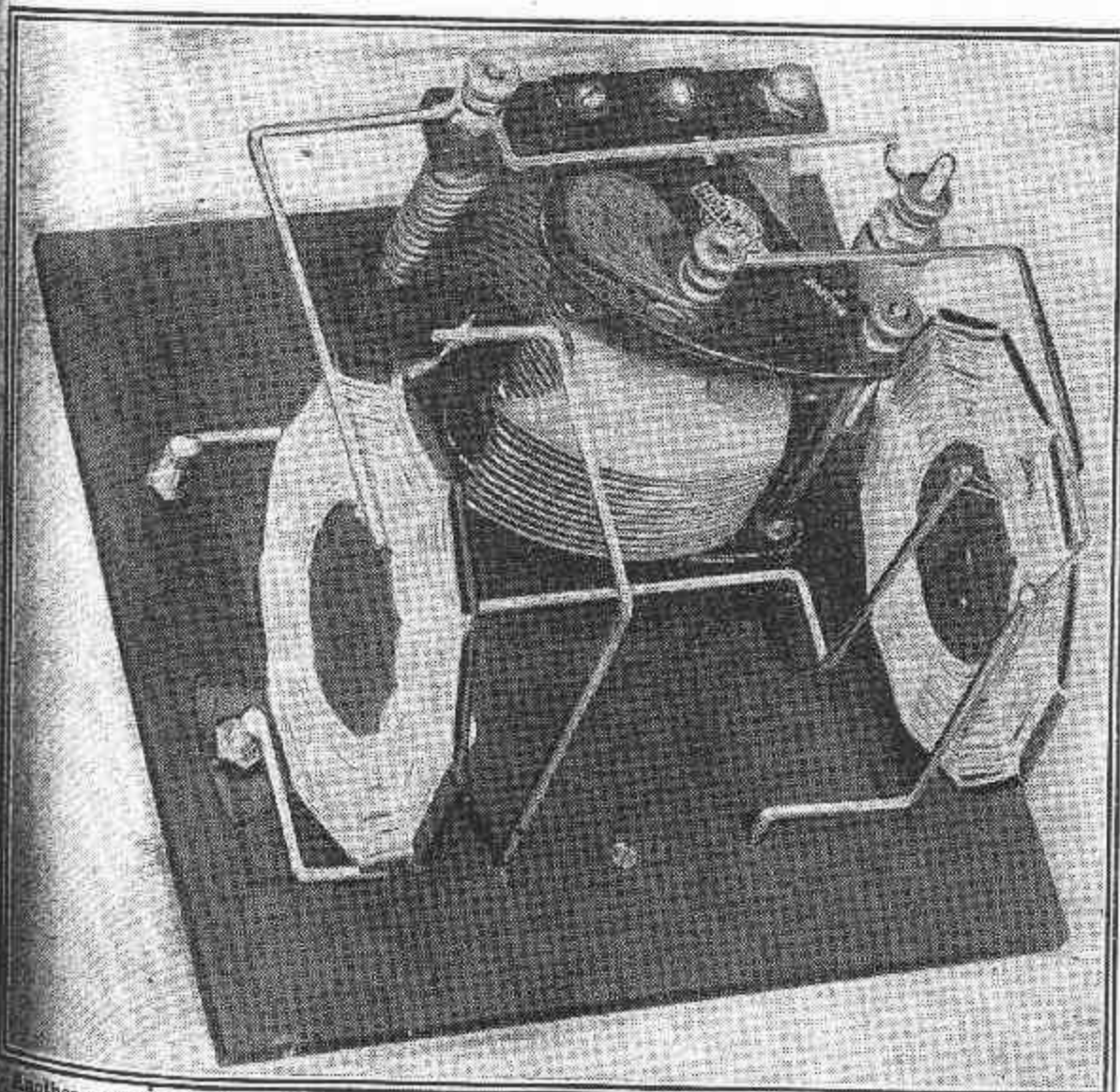

Another underpanel view of the crystal set which should be useful when the receiver is being wired up.



# TWO LOW-COST CRYSTAL SETS



**C**RYSTAL sets never lose their appeal because they offer so much radio for so little money and because they give satisfactory reception on local stations. All you need is a good pair of 2,000-ohm headphones, a few scrap materials, and a crystal detector to build an efficient broadcast receiver of this description. Complete crystal detectors cost about 25 cents, or you can assemble your own holder and mount a small piece of galena mineral. A safety pin, or a piece of stiff wire, will serve as an adjustable contact point.

Crystal circuits are of infinite variety. Some are quite selective and will separate strong local broadcasting stations in crowded localities; others of simpler design are intended to receive only the strongest station in a given area. The usual range for any crystal receiver is about 40 miles for powerful broadcasting stations, although greater distances have been covered under favorable receiving conditions or with elaborate antenna and ground systems that are not practical from an economical standpoint. In every case maximum range is obtained with a long and high outdoor antenna and a ground on a cold water pipe, rather than with trick circuits. For distant stations the antenna should be 150 feet long or longer.

Schematic circuit diagram Fig. 1 shows a crystal set reduced to its simplest fundamentals. It consists of a coil, tapped for tuning, and a crystal detector. This set is intended for use only in a city which has but one broadcasting station powerful enough to give a good signal on crystal sets. The coil is wound on an ordinary plastic drinking cup of the "dime" store variety as detailed in the pictorial diagram

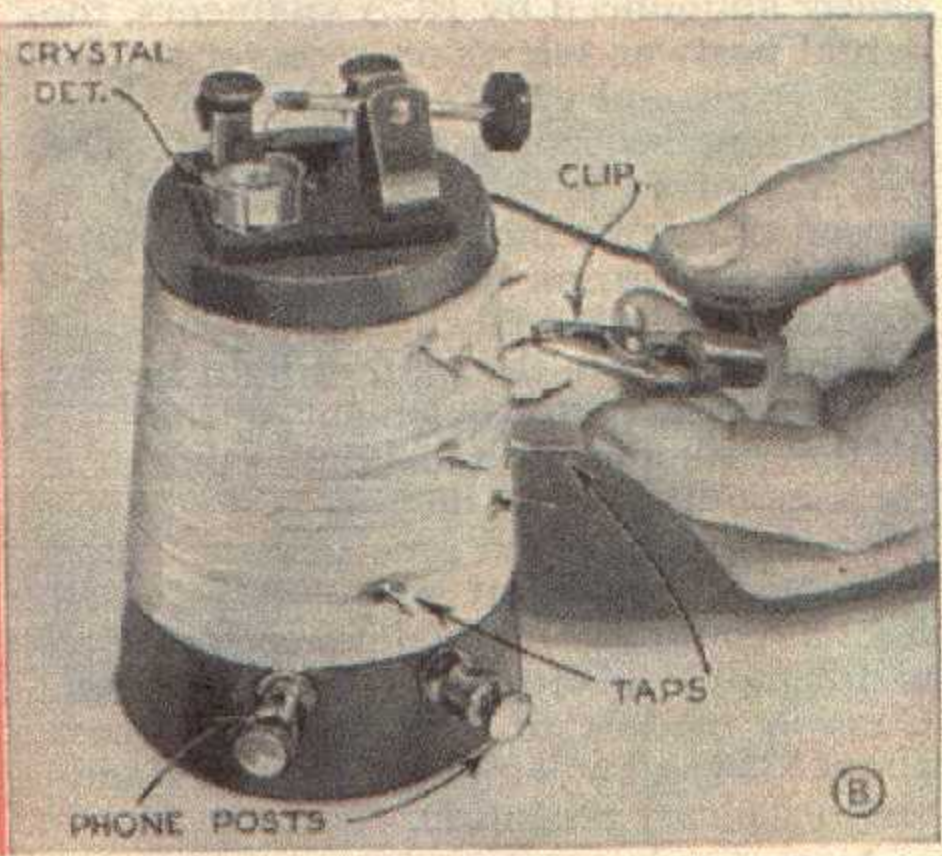
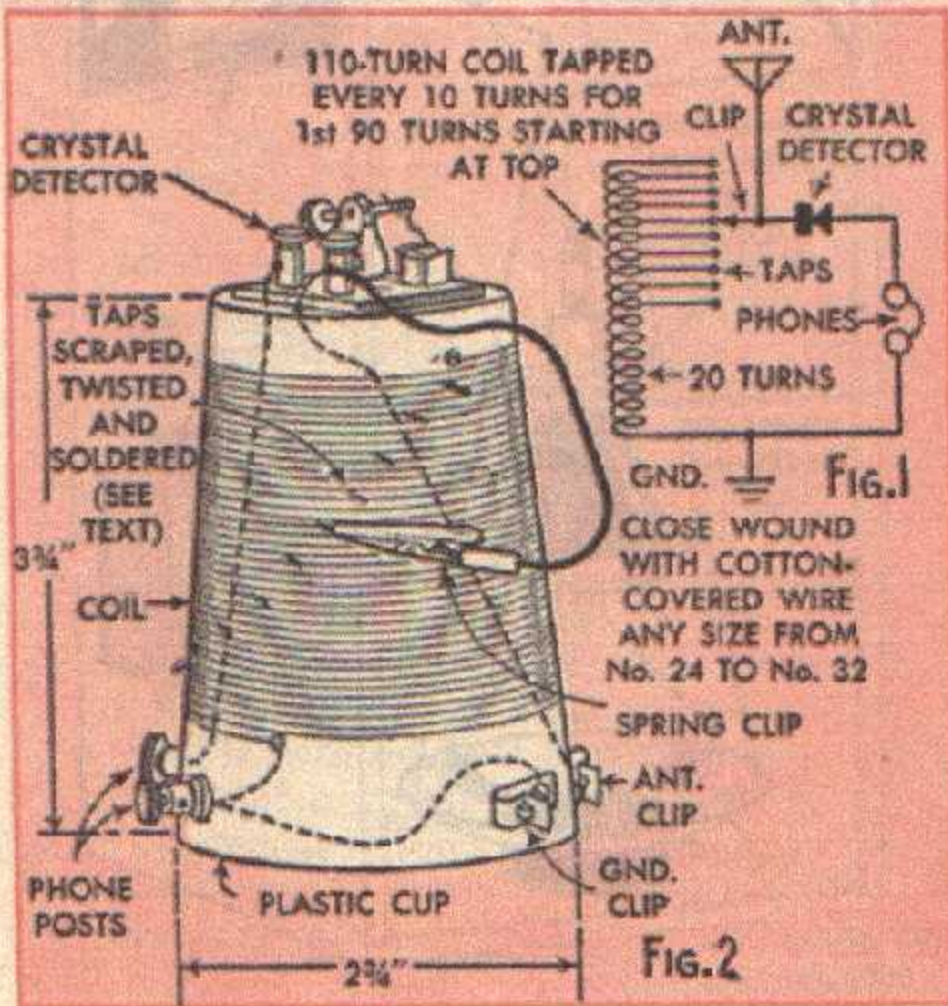
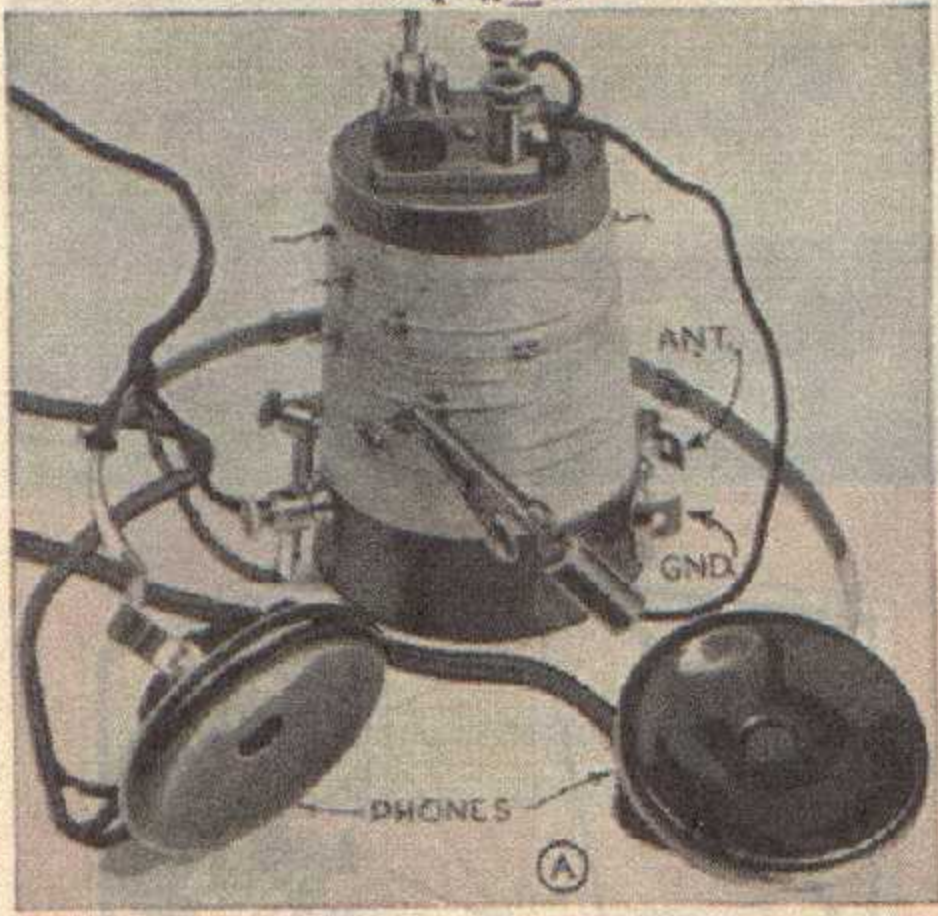



# For EXPERIMENTERS

Fig. 2 and photos A and B; the total cost was approximately 50 cents. The coil tuning taps are made by scraping the insulation from the wire at the tap point, twisting it and applying solder so that it will stand out and provide a terminal for the "bulldog" spring clip. The standard adjustable crystal detector is mounted on top of the cup. Two Fahnestock spring clips and two binding posts complete the assembly.

A really selective crystal receiver is shown in photo C; the schematic circuit appears in Fig. 3 and simplified pictorial wiring diagrams are given in Figs. 4 and 4-A. It includes a wave-trap and employs two 2-gang variable condensers that were salvaged from old broadcast receivers. As only one section in each 2-gang condenser is used, single-section condensers of the same capacity may be substituted. The set is tuned with variable condenser  $C_1$  at front; interfering stations are tuned out with the wave-trap condenser  $C_2$ . Detailed student material list R-335 is available from Popular Mechanics radio department upon receipt of ordinary letter postage.

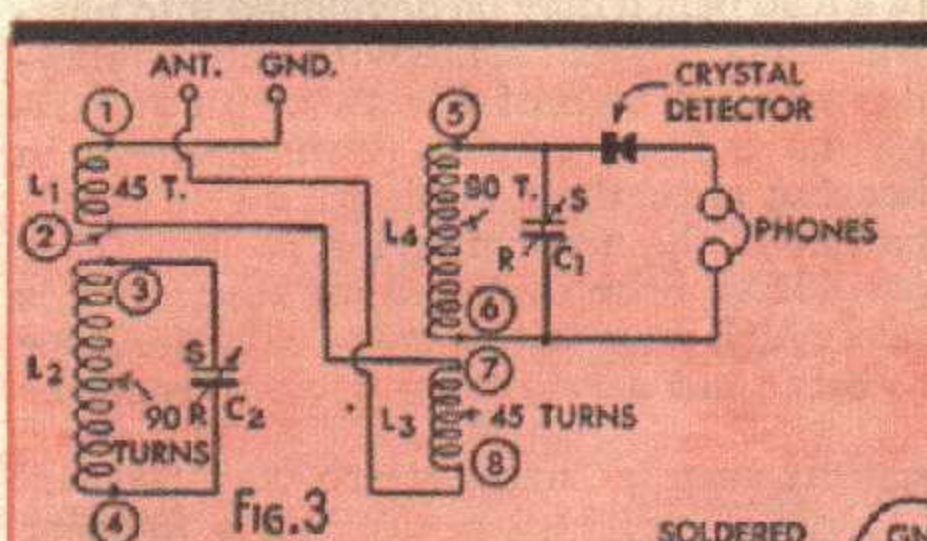
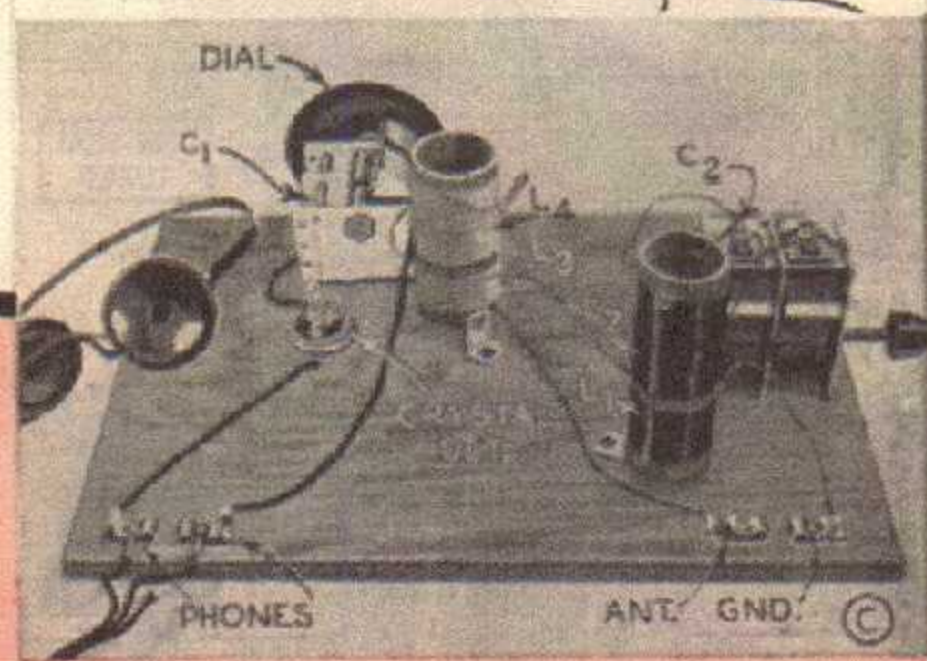

FIG. 3

NOTE  
 $C_1$  AND  $C_2$ —SINGLE SECTIONS OF TWO OLD 365 MMFD. 2-GANG VARIABLE CONDENSERS



FIG. 4-A

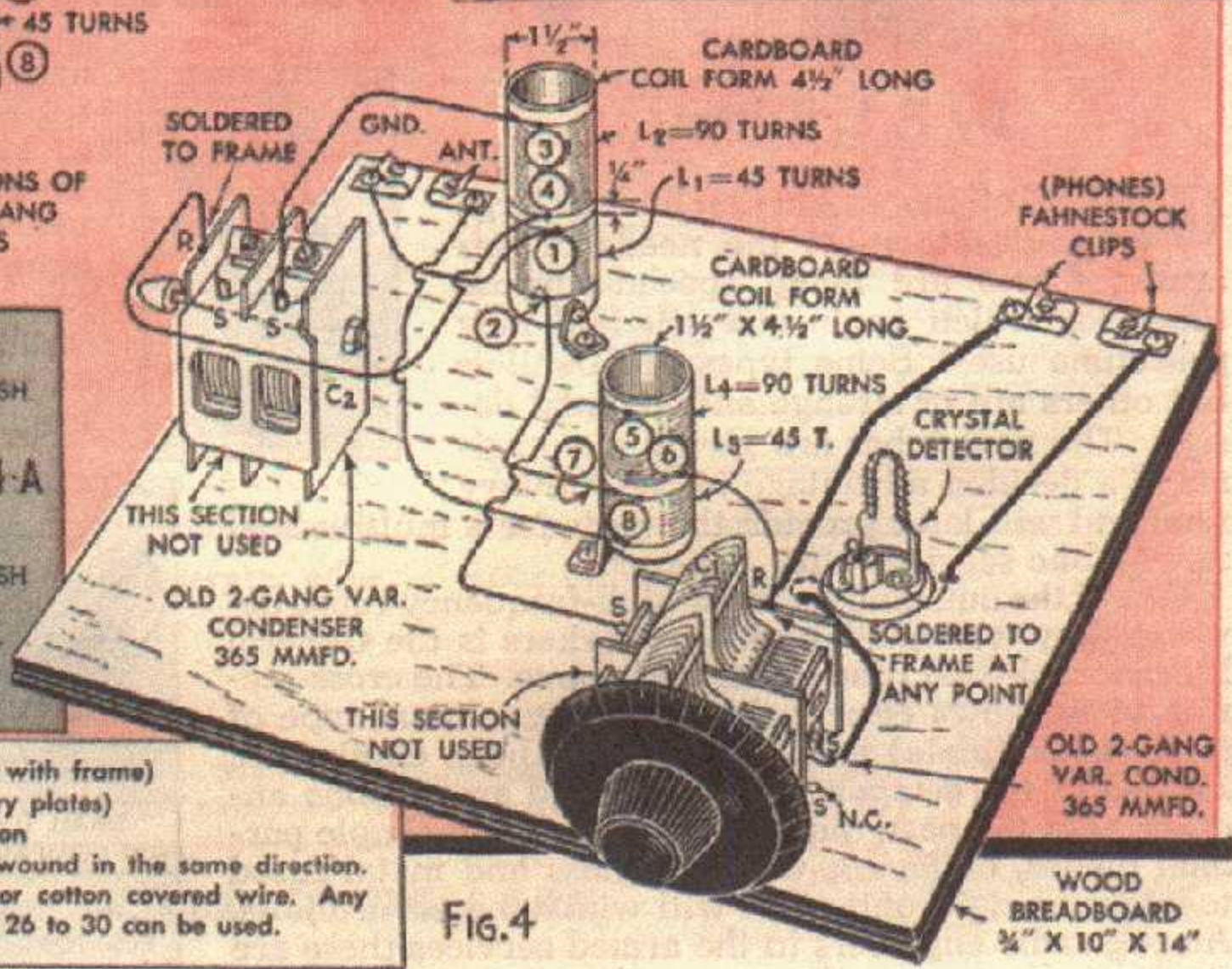

FIG. 4

NOTE—R—Rotor (common with frame)  
 S—Stator (stationary plates)  
 N. C.—No connection  
 All coils are close-wound in the same direction.  
 No. 26 enameled or cotton covered wire. Any size wire from No. 26 to 30 can be used.



# THREE GERMANIUM DIODE CRYSTAL

By L. M. Dezettl

CRYSTAL sets have been a favorite of experimenters for many years as they are easy to build and they reproduce voice and music with true lifelike quality. The three crystal sets described here use sensitive Sylvania 1N34 germanium diodes as fixed crystal detectors. The diodes are available from all radio-parts houses.

Set No. 1, shown in photo A, is assembled on a  $\frac{3}{4}$  x 5 x 9-in. piece of well-sanded soft pine wood. All parts are mounted with  $\frac{1}{2}$ -in. No. 6 roundheaded wood screws. Set the parts up on the baseboard and mark the locations for the wood screws. Use a No. 36 drill, and drill about halfway into the wood at each of these points. Small angle brackets are employed to mount the variable condenser on the baseboard. Use  $\frac{1}{16}$ -in. 6-32 machine screws to fasten the brackets to the variable condenser; do not use longer machine screws. The same assembly method is used for all three receivers.

The schematic circuit diagram for set No. 1 is shown in Fig. 1, and the pictorial wiring diagram appears in Fig. 2. This is a standard crystal-set circuit using an inexpensive factory-wound coil. Variable condenser C1 can be any capacity between 365 mfd. and 500 mfd. It will provide reasonably loud signals from



SET NO. 1

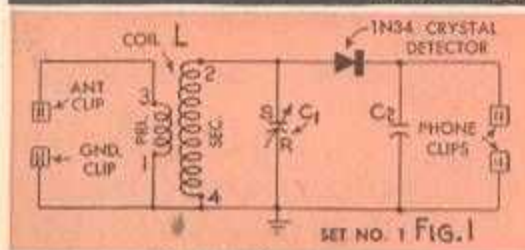

SET NO. 1 FIG. 1

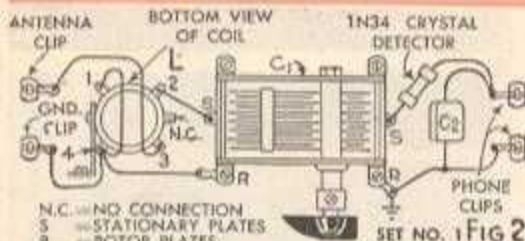

- N.C. = NO CONNECTION
- S = STATIONARY PLATES
- R = ROTOR PLATES (COMMON WITH CONDENSER FRAME)
- L = MEISSNER NO. 14-1010 ANT. COIL
- C1 = 365-500 MMFD. VARIABLE CONDENSER
- C2 = 001 MFD. MICA FIXED CONDENSER

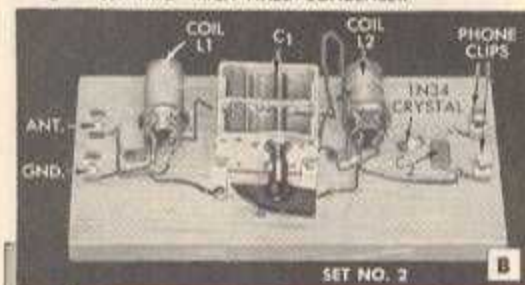

SET NO. 2

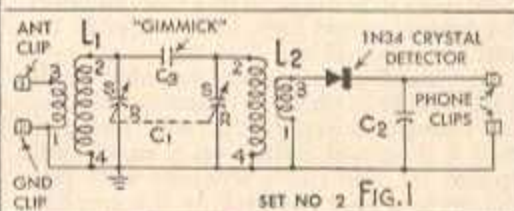

SET NO. 2 FIG. 1

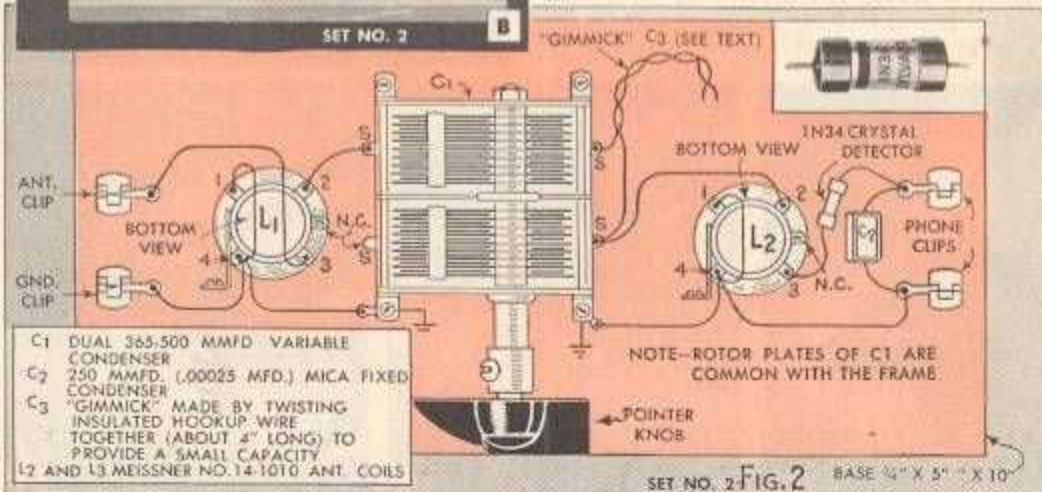

- C1 DUAL 365-500 MMFD. VARIABLE CONDENSER
- C2 250 MMFD. (.00025 MFD.) MICA FIXED CONDENSER
- C3 "GIMMICK" MADE BY TWISTING INSULATED HOOKUP WIRE TOGETHER (ABOUT 4" LONG) TO PROVIDE A SMALL CAPACITY
- L2 AND L3 MEISSNER NO. 14-1010 ANT. COILS

SET NO. 2 FIG. 2 BASE  $\frac{3}{4}$  X 5 X 10



# RECEIVERS FOR BEGINNERS . . .

local broadcasting stations in dual-type headsets with an impedance of 2000 ohms, or higher. The antenna should be a high, well-insulated outdoor type at least 100 feet long, although antennas as short as 40 feet will work. The ground should be made to a cold-water pipe.

The practical receiving range of any crystal receiver is limited to about 40 miles for powerful broadcasting stations. Set No. 2 is double-tuned for improved selectivity. Two coils like the one used in set No. 1 are employed and each coil is tuned by one section of a dual variable condenser. Coupling between the two tuned circuits is by means of a "gimmick" made by twisting two pieces of insulated wire together for a length of about 4 in. This is condenser C3. The longer this "gimmick" the louder the signals, but the poorer the selectivity.

Set No. 3 is an experimental arrangement using two 1N34 diode crystals in push-pull to provide louder signals than conventional crystal circuits. The coils are hand-wound to provide a split secondary winding with a primary winding between. Both primary and secondary are tuned. The dual-section variable condenser tunes the secondary of the coil to the frequency of the station. Condenser C2 in primary L3 tunes the station but it has its greatest effect on very long antennas. If the desired station operates on 850 kc. or higher, "open" the toggle switch on the bracket. Detailed student material list is R-396.

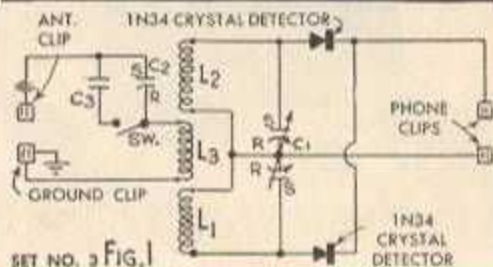
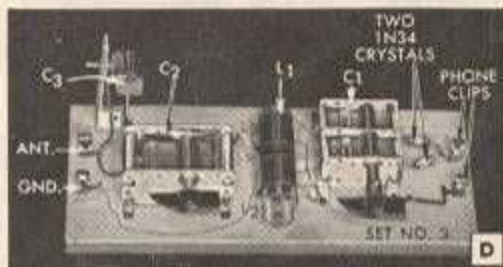

- SET NO. 3 FIG. 1
- C1 DUAL 365-500 MMFD. VARIABLE CONDENSER
  - C2 SINGLE 365-500 MMFD. VARIABLE CONDENSER
  - C3 001 MFD. MICA. FIXED CONDENSER
  - L1 HAND-WOUND COIL ON A 1" DIA. POLYSTYRENE TUBE (SEE TEXT)
  - L2 AND L3 120 TURNS OF NO. 32 ENAMELED WIRE
  - L3 43 TURNS OF NO. 32 ENAMELED WIRE
  - ALL THREE COILS ARE CLOSE-WOUND IN THE SAME CLOCKWISE DIRECTION AND SPACED 1/8" APART
  - NOTE-VARIABLE CONDENSER ROTORS ARE COMMON WITH FRAMES

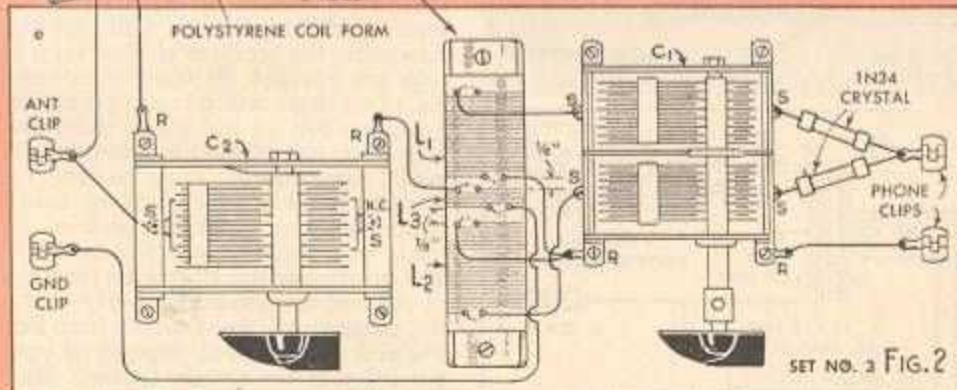
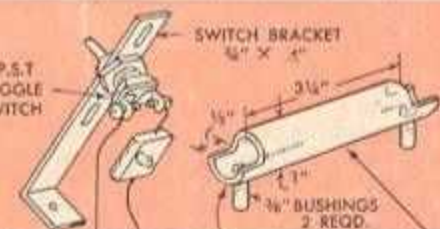

NOTE - N.C. = NO CONNECTION

BASE 1/2" X 5" X 12"



# Tapped Coil Crystal Set

**T**HIS easily constructed crystal receiver which uses few parts, needs no power supply, has a minimum of adjustments, and will give clear reception over a limited area. It is designed to give maximum selectivity in metropolitan areas where several high-powered radio stations may be found. Where *selectivity* is not necessary, you can adjust this set to provide maximum *sensitivity* by placing extra taps on the secondary winding while constructing the coil, as we will explain later.

The receiver may be mounted on a board  $4\frac{1}{2}$  by 6 in. or it may be placed with the earphones in a cigar box for easy carrying. Before beginning construction, carefully examine both schematic and pictorial diagrams. It's wise for beginners to work with the pictorial diagram while doing the actual construction, as it shows positions and identities of each part, wire and connection. Then, as construction progresses, they should check



Want to try a receiver with fixed crystal detectors?  
Here is a selective circuit with few components

By MILO ADLER



The crystal set is shown above mounted in the cigar box with headphones in place beside it.

with the schematic in order to become familiar with the symbols used and to better understand the actual workings of the circuit and its operating principles. When you can follow more complex circuits, and the symbols, part functions, and wiring procedure are completely familiar, you only need the schematic as a guide.

First drill two holes for mounting the coil  $\frac{3}{8}$  in. from each end of the coil form and just large enough to pass the  $\frac{5}{16}$  in. machine screws used for mounting the coil. Next drill two holes shown at A in the pictorial diagram in the coil form, locating the first hole  $\frac{3}{8}$  in. from end of coil form as mentioned above and the second hole  $\frac{1}{8}$  in. from the first one. Then carefully unwind 5 to 10 ft. of No. 22 enameled wire, being sure not to kink it as a kink may cause it to break while coil is being wound.

Pass about 5 in. of wire through the second of the two small holes in the coil form from the outside of the coil form towards the inside. Next pass the same wire through the first of the holes from the inside of the coil form, and pull small loop on inside of form taut. Fasten coil of wire



to a stationary object or have someone hold it, being careful not to cause any sharp bend in the wire. Pull the wire taut and slowly rotate the coil form, thus winding the wire on the form. Wind 20 turns on the form for the primary winding. Stop every few turns and press the turns of wire together so that coil form cannot be seen between turns of wire. After 20 turns are wound on the coil, leave approximately 5 in. of excess wire and cut off the remaining portion.

Drill three small holes at point B (see pictorial diagram) and fasten end of primary winding through two of these holes in the same manner as the beginning of the coil winding, using two of the holes. Use the center and remaining hole at B to fasten beginning of secondary winding. Start the secondary winding as you did the primary, with a 5 in. lead coming from the coil, and place 30 turns on the coil form. Place the tap (T in diagram), at 30 turns from point B on the coil; this tap or loop is made by scraping the black enamel coating from the wire, twisting to form a small loop, and soldering the wire together.

Now place the remaining 80 turns of the 110-turn secondary on the coil form and fasten end of winding through two small holes (at C in diagram). If you want to be able to adjust the sensitivity and selectivity of this crystal

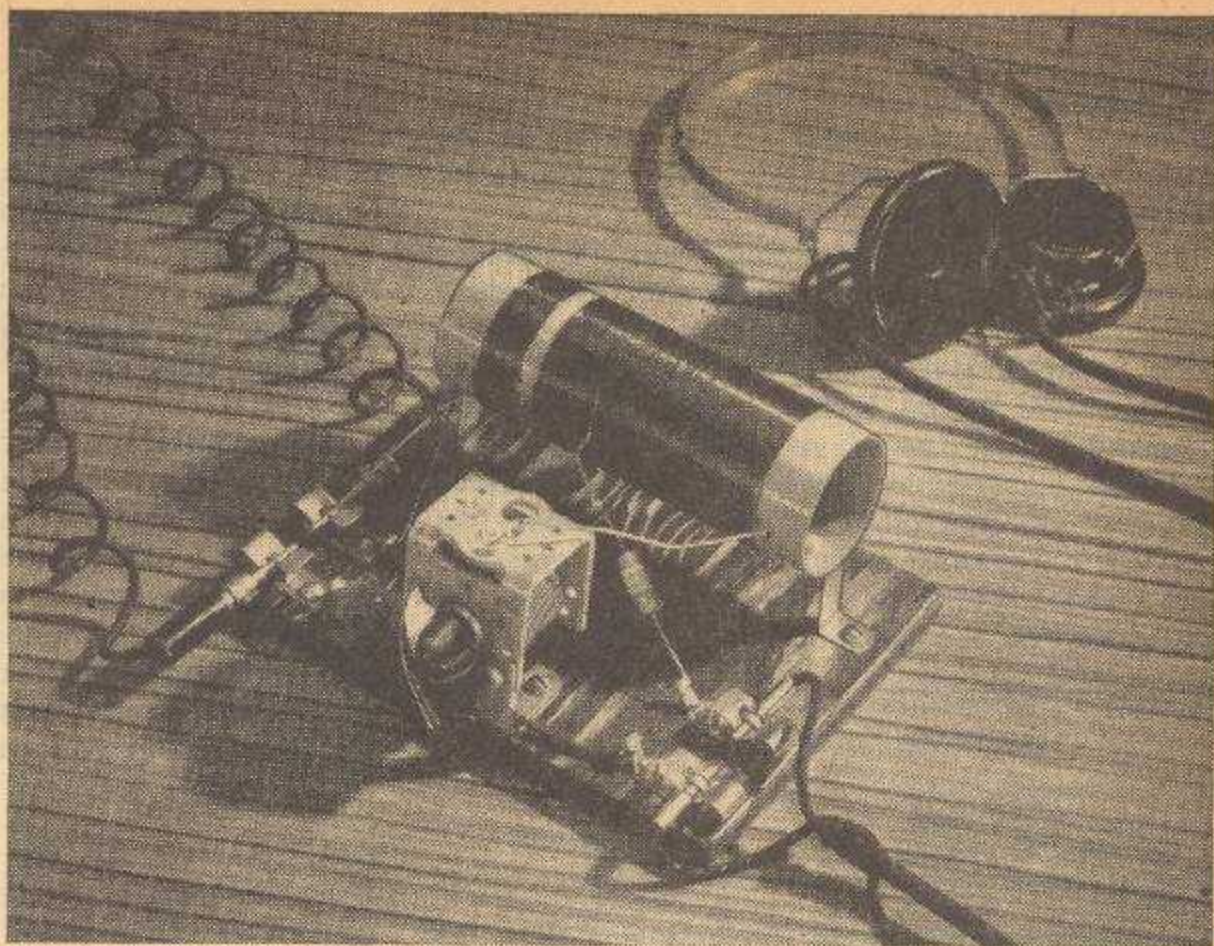

Completed "breadboard" version of crystal set with headphones connected.

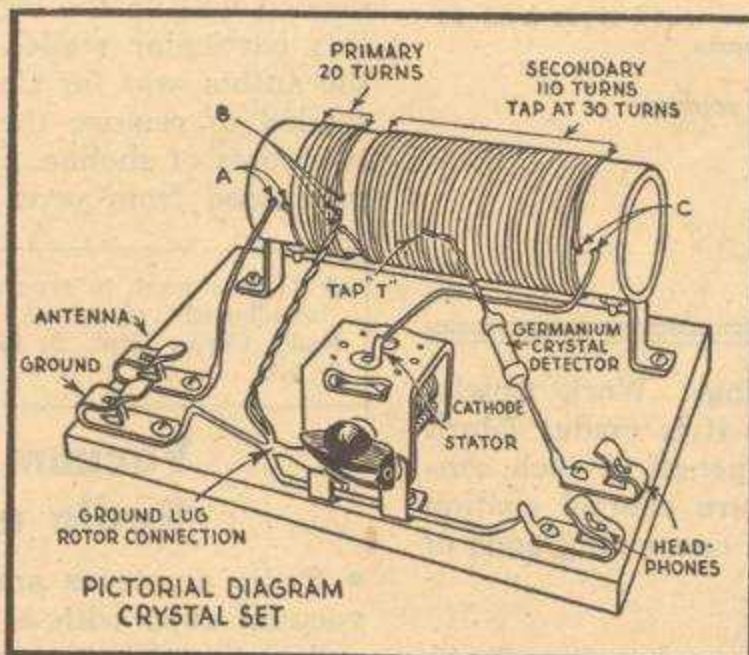

set, place taps every 10 to 15 turns while winding the secondary winding. But don't place any taps on the secondary before the first 30 turns.

Receiver construction will vary depending upon whether a "breadboard" or cigar-box model is to be constructed. The wiring of the receiver will be the same regardless of which model is constructed, so instructions for constructing the "breadboard" model will be

given first, followed by instructions for mounting parts in a cigar box.

For the "breadboard" model, first mount the coil mounting feet on the coil form, taking care not to damage the coil. Then mount coil as shown on the pictorial diagram. Next mount the variable (tuning) condenser with angle brackets; be sure to place a solder lug under condenser mounting screw, as shown in the pictorial diagram. Fasten clips to baseboard with wood or self-tapping metal screws.

If receiver is being constructed in a cigar box, after coil is completed cement coil in location shown in photo, using a quick drying radio or model builders' cement. Let cement dry thoroughly before doing any further work on the set. Then mount the variable condenser in the box with cement and two No. 6 by 1/4 in. wood or self-tapping sheet metal screws. Mount the

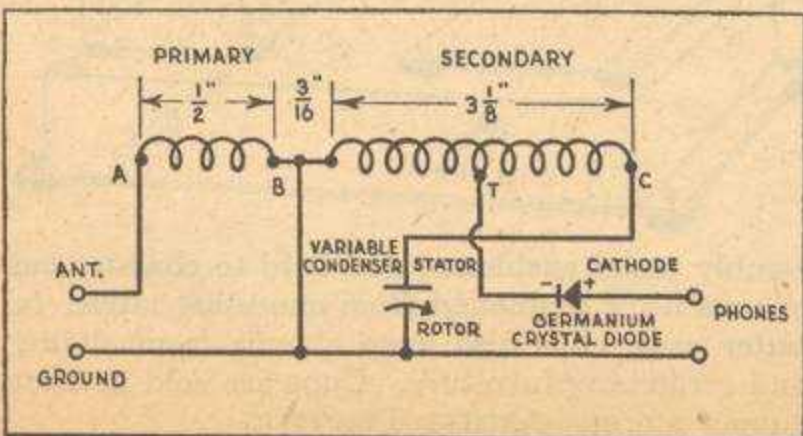



four clips for headphone, antenna and ground connections in the box with the same size screws that were used to mount the tuning condenser. Be sure to mount a soldering lug on the frame of the tuning condenser with a No. 6 by  $\frac{1}{8}$  in. machine screw.

Solder all connections, using rosin core solder only (acid-core solder and acid flux may cause corrosion). Pre-heat parts for easier, better work by holding soldering iron tip against wire and terminal to be joined for a few seconds. Then apply just enough solder to cover connection and fill crevices between wires. Remove iron, but do not move wires until solder has set—this takes only a few seconds. When more than one wire is to be connected at a particular point, don't solder and resolder. Install all wires

---



---

#### MATERIALS LIST—CRYSTAL SET

##### Receiver Parts:

- 1  $1\frac{1}{2}$ " x 5" coil form
- 55 feet No. 22 enamel wire
- 1 .381.4 mmfd. midget single gang condenser (Allied 61-009)
- 1 Germanium crystal diode (Sylvania type 1N34; Allied 7-219) or General Electric type 1N48 (Allied 7-250)
- 1  $1\frac{1}{4}$ " pointer knob
- 4 Fahnestock clips
- 1  $4\frac{1}{2}$ " x 6" x  $\frac{3}{8}$ " plywood base or wood cigar box, depending upon model being made
- 8 No. 6 x  $\frac{1}{4}$ " woodscrews
- 2 6-32 x  $\frac{5}{16}$ " or longer machine screws
- 2 coil mounting brackets
- 2 condenser mounting brackets
- 1 solder lug

##### Accessories:

- 1 2000 ohm headset
- 1 antenna kit (Allied 83-100)

---



---

to that point before soldering. Work slowly, checking each connection as it is made. Mark the diagram with a colored pencil as each connection is completed. Be sure enamel coating on wire is scraped off before connecting ends of coil into set.

#### Cure for Weak Stations

To get the best results, use a good antenna, good ground, and a pair of high-resistance headphones (1000 ohms or higher). In most cases a long antenna is unnecessary. However, if stations are weak, or if nearest one is a great distance from you, you may need to secure an antenna at least 50 ft. long and as high as possible, and adjust set for maximum sensitivity by moving connection at point T over to point C (see diagram). Use glass or porcelain insulators at the antenna ends and rubber-covered wire for a lead-in to prevent contact with grounded objects.

If taps are made on secondary winding when coil is constructed, move connection to crystal diode up and down coil until a tap is found which gives the best performance for the station being received. For a ground, drive a few feet of metal rod or pipe into moist earth or make a connection to a cold water pipe or radiator.

The broadcasting station microphone converts sound to an auto frequency (AF) current which fluctuates as the sound changes in pitch and volume. This AF current is an electrical pattern of sounds picked up by the microphone. Since it cannot be transmitted alone it is combined with a strong, steady radio frequency (RF) current. The combination is sent out through an antenna, becoming radio waves. The RF signal is called the "carrier" because it "carries" the AF signal. Some of these waves will strike your receiver antenna, setting up a current which travels to the set. The crystal detector "demodulates" the signal—that is, it takes out the RF signal, but allows the AF to continue to the headphones where it is converted to sound. The coil and tuning condenser select a particular signal from the many constantly striking your antenna. Hence you adjust the condenser to "pick up" the station you want.

#### Kit Available

A complete kit for constructing the "breadboard" model of this receiver is available at a cost of less than \$3.00. This kit contains all materials necessary for constructing the "breadboard" model. The only extra components needed will be the cigar box when constructing this particular model. The cigar box used by the author was for Corina Larks cigars. It was sanded to remove the printing and then given two coats of shellac. The handle shown may be purchased from your local hardware store.

• If you want to secure the kit for constructing the "breadboard" model of this crystal set, write Allied Radio Corp., Dept. S, 833 W. Jackson Blvd., Chicago 7, Ill.

## Vacuum Cups Give Radio a Soft Ride

• Radio amateurs and experimenters find that vacuum cups with a machine-screw molded in and a thumb-nut attached, make good rubber cushions and shock absorbers on a receiver or transmitter chassis. Sketch shows a gang-condenser held and cushioned on chassis, a sub-as-

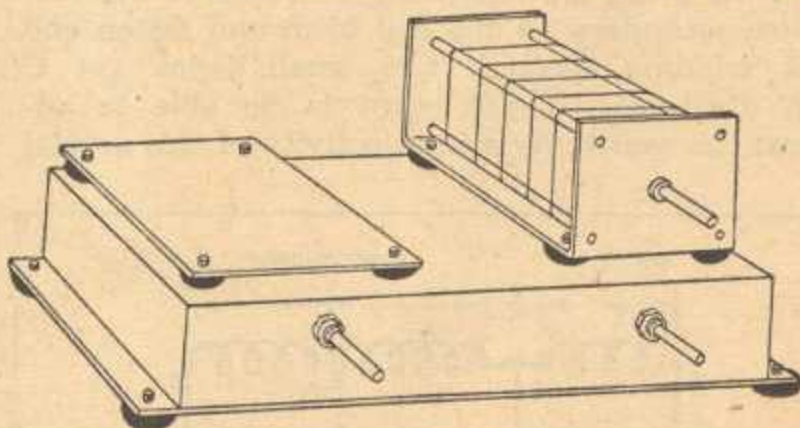

sembly panel cushioned and held to chassis, and chassis itself cushioned from operating table. In latter case, cups also keep chassis from sliding and scratching furniture. Cups are sold in most supply stores.—ARTHUR TRAUFFER.



# Tapped Coil Crystal Radio

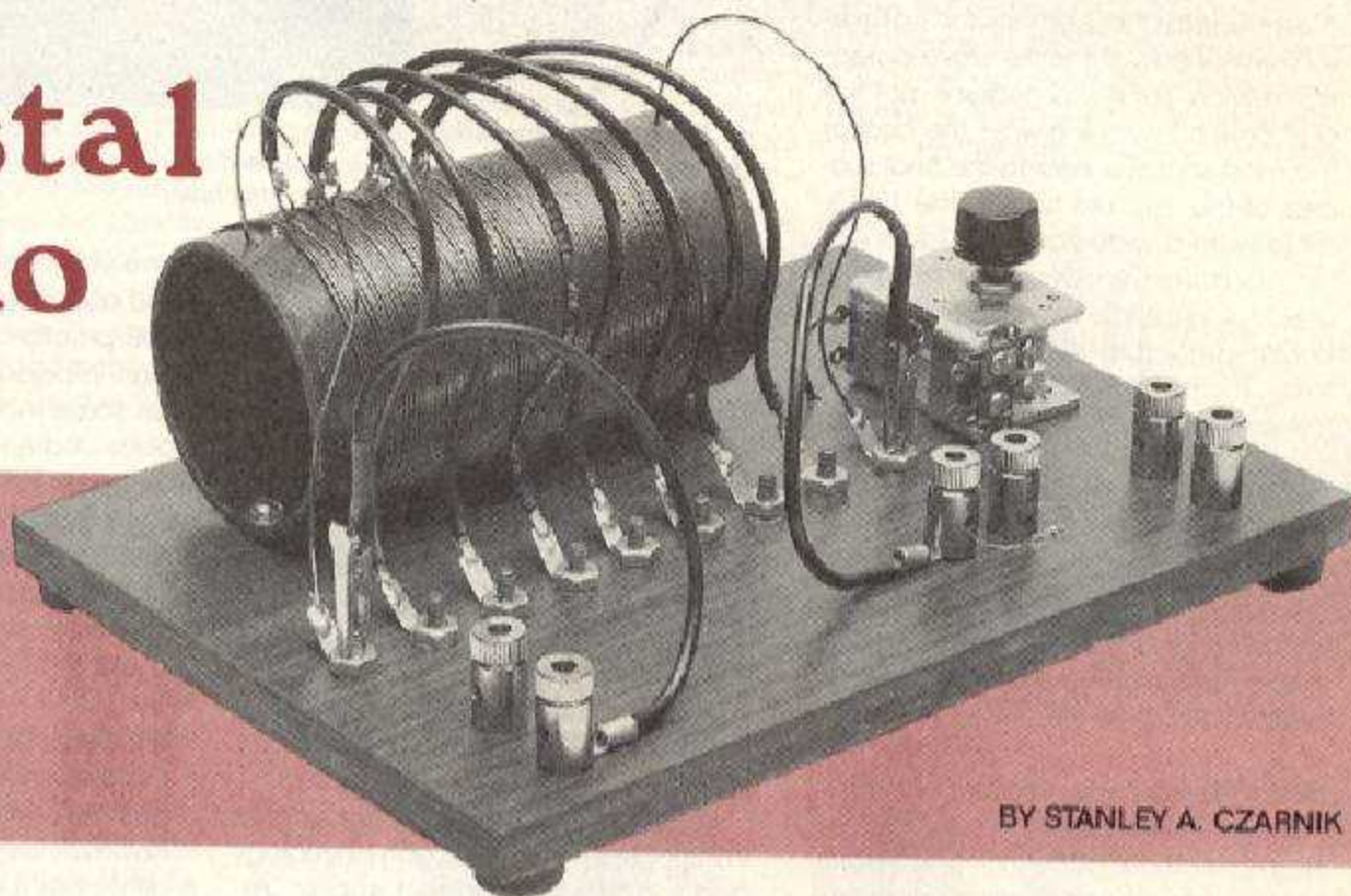

BY STANLEY A. CZARNIK

*There's many a way  
to tune a crystal receiver.  
This golden oldie does it  
with a tapped coil  
and variable capacitor.*

**T**racing the origin of crystal radio-wave detectors (that's what they called 'em in Grandpa's day) can be a little tricky. One reason is that it took some time for experimenters to appreciate the nature of crystal detection and crystal rectification.

The first relevant discovery was made in 1874 by the German physicist, Karl Ferdinand Braun. Braun noticed that certain metal sulfides conducted electricity in an unsymmetric fashion. The current, in other words, would pass very easily in one direction, but with great difficulty, or resistance, in the other di-

rection. The effect, of course, is rectification, but Braun did not realize that until 1883. Finally, in 1901, Braun harnessed his crystal rectifier to the purpose of radio-wave detection.

**Crystal Detectors.** In the United States, it was H. H. Dunwoody who discovered the crystal radio-wave detector in the year 1906. The crystal was a piece of carborundum, otherwise known as silicon carbide. Silicon carbide is also the first solid substance known to be electroluminescent. Just imagine: strange illuminations from a crystal set! The phenomenon came to be called *Detektorleuchten*, literally, *detector lights*.

Crystal detection and rectification got a lot of attention. It was very quickly noticed that several natural substances could detect radio waves when in contact with a tiny metal point or small piece of fine wire. Among the substances tried were: galena (lead sulfide), iron pyrites (iron sulfide), molyb-

denite (molybdenum sulfide), zincite (zinc oxide), cerusite (lead carbonate), and silicon. The wire contact was most often made of gold, silver, copper, or bronze. There were many types of crystal-detectors, but each of them provided a means of holding the mineral specimen and a way of controlling the position and pressure of the wire contact, often called the *cat's whisker*.

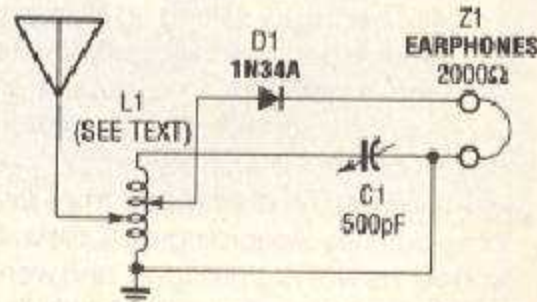

*Fig. 1. What makes this crystal radio special is the tapped RF coil. Apart from that, the circuit is similar to many other simple crystal receivers. Exactly where and how the various parts and components are mounted is up to you, but follow the layout shown in the photos if this is your first radio project.*



In some detectors, the cat's whisker was replaced with a second mineral different from the first. The two-crystal system was marketed under trade names like Periken Detector, the Pyron, and the Bronc Cell. The two-crystal detector, never very common, was actually more reliable than the conventional single crystal and cat's whisker arrangement.

**Alternatives.** The crystal detector was a very simple and, perhaps for that reason, a very popular radio-wave detection device. But it was certainly not the only one, nor was it always the best or the most sensitive. Prior to the final success of the vacuum tube in the 1920's, there were a wide variety of other detectors based on every conceivable physical principle. There were electrolytic detectors, electrostatic detectors, magnetic detectors, thermal detectors, primitive spark-gap detectors, and of course the famous *coherer*, which was often little more than a glass tube supplied with two electrodes and some iron filings.

There is also at least one recorded instance of a radio-wave detector made from, believe it or not, a disembodied human brain.

**Brain Waves.** In September of 1901, A. Fredrick Collins performed a series of experiments designed to "verify, if possible, the casual observation long since made that approaching electrical storms manifested their presence in persons afflicted with certain forms of nervousness and other pathological conditions, though the storm influencing them might be many miles beyond." Collins reasoned that, somehow, the brain picks up the electrical disturbances in the air just as a radio-wave detector reveals the presence of sparks from a spark coil.

Collins began by setting up a simple spark transmitter and an equally simple receiver connected to a couple of needles for insertion into his experimental brains. He started with an unidentified mammalian brain from the local butcher. According to Collins, it worked. He was encouraged, and went on to repeat the experiment with the living brain of an anesthetized cat. According to Collins, that worked too.

If anybody knows or is able to discover more about A. F. Collins and his brain radio, I would very much like to hear from you. You can write to me in care of **Popular Electronics**—Stanley A. Gzarnik

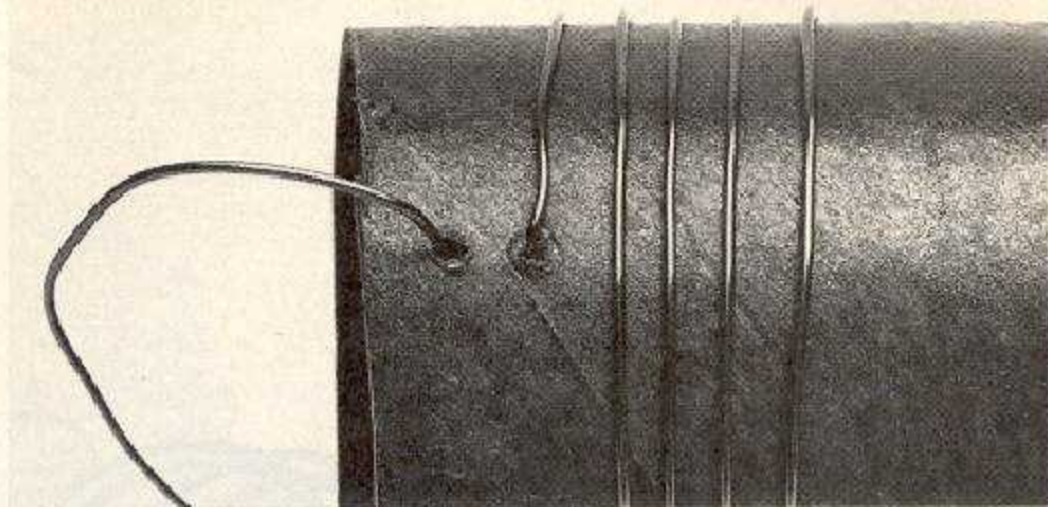

**1** Begin coil L1 by pushing a length of 20- or 22-gauge magnet wire down and then up through two small holes punched near the end of the cardboard coil form. Follow that with 4 turns of wire around the tube.

Finally, and inevitably, Collins decided to try a human brain. "It is a most difficult object to obtain," he says. But he did find one, nice and fresh, a "magnificent specimen." He placed the brain on a slab of glass, inserted the needles, and completed the wiring using his battery-operated telephone receiver. Collins claims that the brain radio enabled him to listen to a bolt of lightning striking a house a quarter mile away.

Without a doubt, Collins' circuit ranks as one of the most ghastly and bizarre electrical devices ever constructed.\*

(Incidentally, Collins was not unique in his interest in both human physiology and electronics. Indeed, many "researchers" of his day explored the ways that electricity could be used to ease human suffering. Many were well meaning and sincere; others had less altruistic motives. For more on that topic, see the article entitled "Electronic Quackery" elsewhere in this issue.)

**The Project.** You do, in fact, require a human brain to build a radio, but the

one you already have will do just fine! You also need a germanium diode, a 500-picofarad variable capacitor, a high-impedance earphone or headset, some magnet wire, and a few other odds and ends. The *Tapped-Coil Crystal Radio* described in this article features a tapped, radio-frequency coil and a fairly sensitive tuning system. Your radio will certainly operate without an internal power supply of any kind (see Photo 1).

**Winding the Coil.** What makes this radio special is the tapped coil (L1). It is also the most difficult part to make. However, building one is not nearly as difficult as it looks. There is an easy way to wind the coil. What's necessary is a medium-size nail, some adhesive tape, and a wooden dowel rod between  $\frac{1}{2}$  and  $\frac{3}{8}$  inch in diameter, six or more inches long.

**Step 1.** Obtain a spool of 20- or 22-gauge, copper magnet wire and a cardboard or thin plastic tube about 2 inches in diameter and about 6 inches long. Punch or drill a small hole about  $\frac{1}{4}$

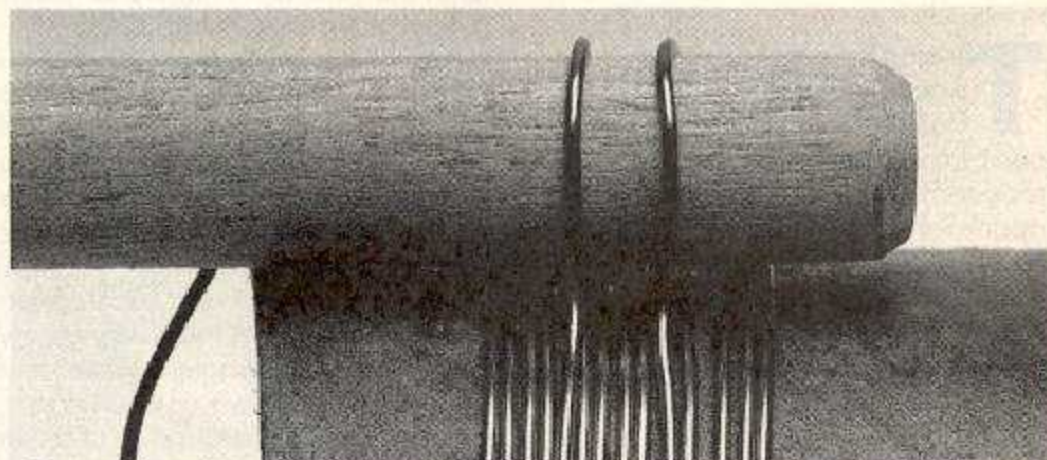

**2** Wind every 5th turn of wire around a wooden dowel rod about  $\frac{1}{2}$  or  $\frac{3}{8}$  of an inch in diameter. Do that for the first 35 turns of wire. Pinch the wire in towards the bottom of the dowel rod with your fingers as you go along.



inch from one end of the tube. Punch another small hole right next to the first one and about 1/4-inch closer to the middle of the tube. Make the holes just large enough to accommodate the magnet wire.

Unroll 8 or 10 inches of magnet wire and push the entire length down through the second hole towards the inside of the tube. Now, push the wire up through the first hole towards the outside of the tube. Pull the wire gently until only a 1/4-inch length of wire lies between the two holes on the inside of the tube. The purpose here is to secure the wire at the end of the tube. That prevents the coil from unraveling. Wind exactly 4 turns of wire around the tube.

**Step 2.** Place the dowel rod directly over the holes and the 4 turns of wire (see Photo 2). Loop the wire around the dowel as shown in Photo 2. Gently pinch the loop in toward the bottom of the rod with your fingers. That loop of wire is destined to become a coil tap. Repeat the operation 6 more times, concentrating the windings together and counting the turns as you go.

**Step 3.** When you're finished you should have a total of 7 loops of wire over the dowel rod. Every loop over the rod will be separated by 4 turns of wire under the rod. In other words, every 5th turn for the first 35 turns will have a coil tap (see Photo 3). After placing the 7th and final loop over the rod, complete the RF coil by winding another 45 turns of wire around the tube. That makes a grand total of 80 turns of wire.

Now, before doing anything else, secure the wire next to both sides of the dowel rod with 2 long strips of adhesive tape. You will want to have the tape handy before you finish winding the coil. Taping the wire down is very important.

Complete **Step 3** exactly like you began **Step 1**, but at the opposite end of the tube. That means making 2 more holes, the first 1/4-inch away from the end of the tube, the second 1/4-inch away from the first. Run the wire down through the second hole and up through the first. Measure off an 8- or 10-inch lead and cut the wire at that point. There, you are now a true master coil winder!

**Step 4.** You're ready to twist your taps. Gently remove the dowel rod from under the wire loops. The loops should remain in their place; that is the purpose of the tape. Obtain a nail 2 or 3 inches long and about 1/8 inch in diameter. Place the nail in the first loop and

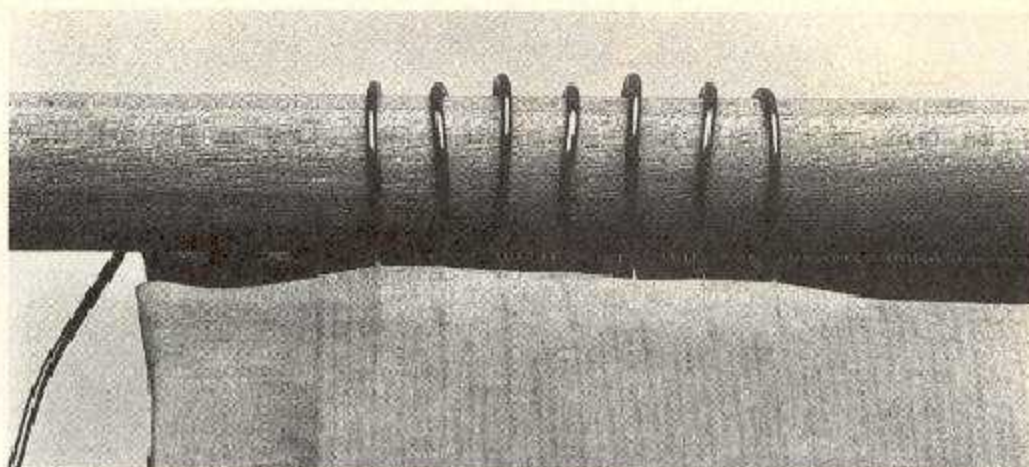

**3** After winding the 35th turn of wire around the dowel rod, finish the coil with another 45 turns of wire. That makes a grand total of 80 turns. Tape the wire in place with two long pieces of adhesive tape. Each of the 7 loops of wire around the dowel rod is destined to become a twisted coil tap.

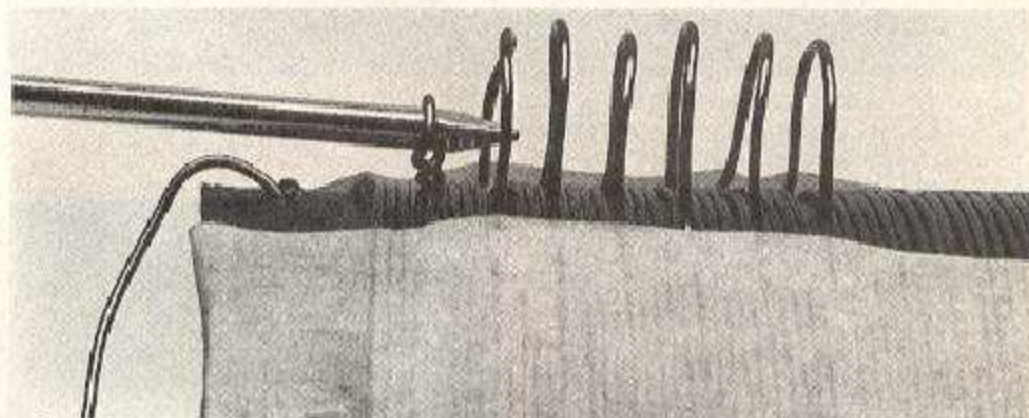

**4** Now remove the dowel rod and, one by one, twist the loops of wire around once or twice with a nail about 1/8 of an inch in diameter. Do not put too much strain on the magnet wire. A little manual dexterity at this point really helps.

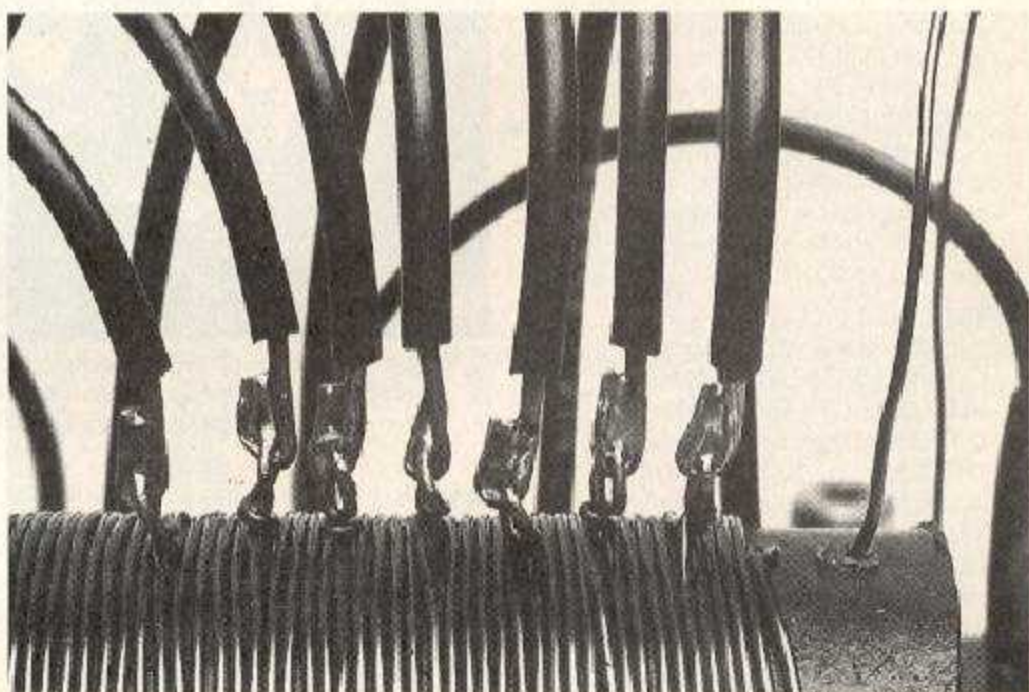

**5** The twisted taps on top of your radio-frequency coil will look something like this when you're all done assembling your coil.

twist the wire around once or twice, or just enough to hold it (see Photo 4). Do not put too much strain on the magnet wire. Remove the nail and repeat the procedure with the other 6 loops.

When you're done, remove the adhesive tape. If you have twisted the taps

properly, the magnet wire will not move and the coil will not unravel.

**Step 5.** Your RF coil is complete, but you still need to wire it up. First get rid of the insulation on each of the twisted taps. One way of doing that is with the sharp edge of an X-acto blade.



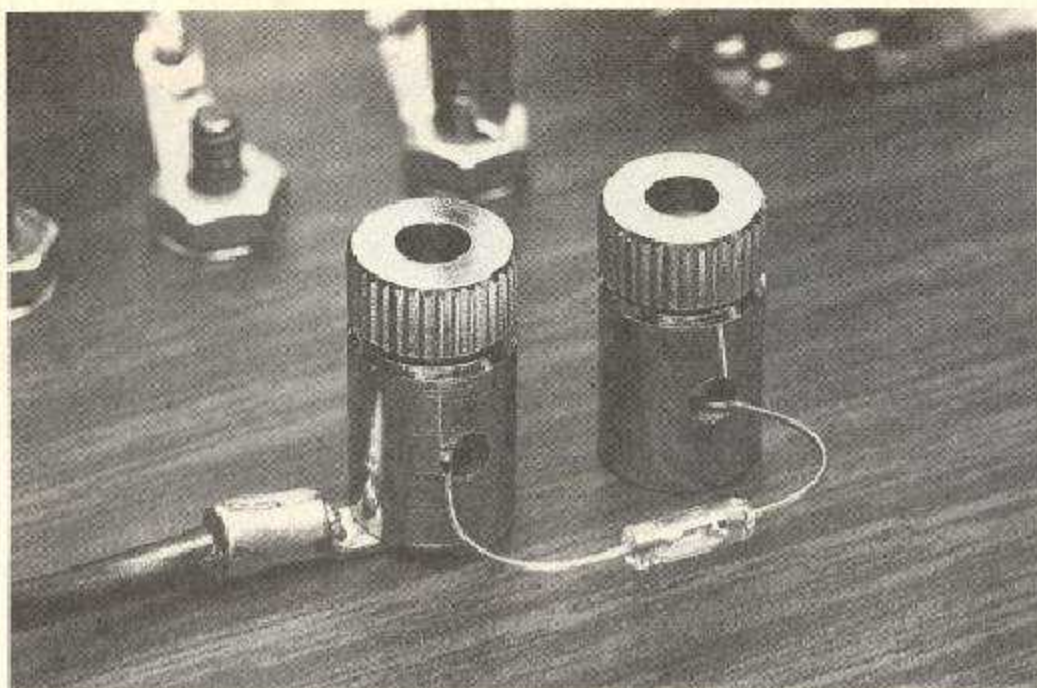

**6** Do not solder the germanium diode (D1) permanently in place. Terminal connectors make it possible to experiment with various other diodes and even other detection devices should you ever wish to do so.

### PARTS LIST FOR THE TAPPED COIL CRYSTAL RADIO

C1—500-pF, variable-tuning capacitor  
 D1—1N34A germanium diode, or equivalent  
 L1—Hand-wound coil (see text)  
 Z1—High-impedance headphones, 2000 ohms or more  
 20 or 22 gauge magnet wire, cardboard or thin plastic tube (about six inches long and two inches in diameter), alligator clips (2), binding posts or Fahnestock clips (6), wooden baseboard (about 6" wide × 8" long × 3/8" thick), wire for antenna and ground connections (about 50 feet), soldering lugs, rubber feet, assorted hardware screws and washers, hook-up wire, solder, etc.

The Tapped Coil Crystal Radio is available as a kit from Yeary Communications, 12922 Harbor Boulevard, Suite 800, Garden Grove, CA 92640. The catalog number is DCTR-1-K and the price is \$10.00. Add 12% for shipping (minimum \$2.00) and \$1.75 for insurance. California residents add 6% sales tax. Also available from Yeary are *All About Crystal Sets* by Charles Green (\$7.95) and *Radios That Work For Free* by K. E. Edwards (\$7.95).

Finally, cut 7 lengths of hook-up wire each about 7- or 8-inches long. Strip 3/4 or 5/8 inch of insulation off one end of each piece of wire, and then, one by one, solder the wires to the coil taps (see Photo 5). You now have finished preparing the most difficult part of the Tapped Coil Crystal-Diode Radio.

lugs and 9 machine screws, one for each coil wire, inserted from the bottom of the baseboard.

You also need a spot for the variable capacitor and places to attach the antenna, the ground, the earphone, and the germanium diode. It is a good idea not to solder the diode permanently to the rest of the circuit (see Photo 6). That makes it possible to experiment with various other diodes and even other detection devices should you ever wish to do so. I chose to use temporary connectors for the antenna, ground, and earphone as well.

**Wiring.** The radio circuit is not complicated and is similar to other simple crystal receivers (see Fig. 1). I recommend putting as many of the connections as possible on the underside of the baseboard. That contributes much to the finished appearance of the project.

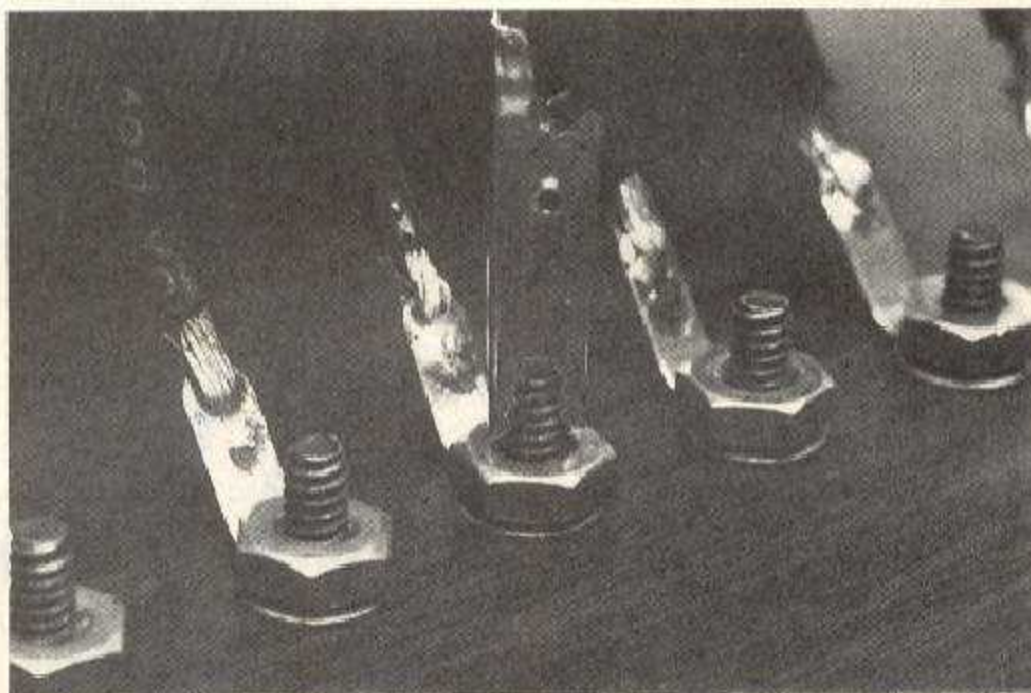

**7** Each coil-tap lead wire is attached to a small soldering lug and a screw inserted from the bottom of the baseboard. Alligator clips provide a means of connection to the coil-tap terminals, and the screws provide a convenient, gripable surface.

**Layout.** The rest of the construction is actually very easy, but it does call for some attention to functional design. You need to think about how the radio will look when you're done with it. Exactly where and how the various parts and components are to be mounted is up to you.

The purpose of the taps on the radio-frequency coil is to provide access to a number of different inductor values. That means each tap lead, as well as the beginning and end of the coil itself, must terminate in some sort of connector. You can use Fahnestock clips or a terminal strip. I used some soldering

Drill all holes first, and that includes 4 holes for the rubber feet necessary to prevent the hardware at the bottom of the board from scratching up the furniture. Now mount the variable capacitor, coil-tap terminals, and binding posts. The radio-frequency coil, which is fairly delicate, should be mounted and wired last after all other connections on the bottom of the baseboard have been completed.

Attach two wires to the rotor (moving plates) of the variable capacitor, C1. Connect one of those wires to one of the earphone terminals and the other  
*(Continued on page 105)*



## TAPPED COIL RADIO

*(Continued from page 36)*

to the first coil-tap terminal. If you have designed a radio similar to the one in the photograph, that will be the terminal on the far left. Attach another wire to the stator (stationary plates) of C1 and connect it to the last (the ninth) coil-tap terminal; that should be the terminal on the far right.

Now run a wire from the other earphone terminal to the cathode of the germanium diode, D1. Run another short piece of wire from the first coil-tap terminal to the ground terminal.

Locate your RF coil and attach it to the baseboard with 2 screws pushed through 2 small holes made on the underside of the cardboard tube. Be very careful not to damage the windings on the coil when you make those holes. The twisted taps should be situated on the top side of the tube.

Now, one by one, solder each coil-tap lead wire to the appropriate coil-tap terminal on the baseboard. Make certain that the sequence of coil-tap terminal connections corresponds to the sequence of twisted taps on top of the coil. The length of the lead wires should be trimmed as you go along.

Complete the radio by attaching one end of a 6-inch piece of hook-up wire to the antenna terminal and the other end to a small alligator clip. Now attach one end of another 6-inch piece of hook-up wire to the anode of D1 and another small alligator clip to the other end. The clips provide a secure means of connection to the coil-tap terminals, and the screws provide a nice place to put the clips (see Photo 7).

**Operation.** There is no space left here for a detailed discussion of antenna systems and ground sources. And anyway, you're probably anxious to try out your new crystal radio. So, go to it!

Attach a wire to the ground terminal of the radio and connect it to a water pipe or a metal water faucet—the one over the kitchen sink, for example. Obtain a long piece of wire and attach it to the antenna terminal. Hang the antenna wire over a nearby door. If you live in or near a big city, such an indoor antenna will work quite well, although a simple outdoor antenna will work even better.

Now, hook up the earphone, and place the alligator clip connected to D1 on coil-tap terminal number 9. Place the other clip (the one connected to

the antenna wire) on coil-tap terminal number 1 or 2. Adjust C1 a bit and you should hear a good, clear signal. Move the antenna clip over to the other coil-tap terminals. Then try moving the other clip. Every time you move the alligator clips, you are changing the inductance of the coil. Now go back and adjust C1. The number of inductor-capacitor combinations is very large, and the clarity and variety of the signals you receive may surprise you.

**Discovering More.** For more information on projects and experiments with crystal radios, see *All About Crystal Sets*, by Charles Green (Allabout Books, Fremont, CA) and *Radios That Work For Free*, by K. E. Edwards (Hope and Allen, Grants Pass, OR), both available from Yeary Communications (see Parts List). For more on the history of crystal sets and other early radio receivers, see *The Cat's Whisker*, by Jonathan Hill (Oresko Books, London) and *Early Radio Wave Detectors*, by V. J. Phillips (Peter Peregrinus, London). For more on the Collins experiment, see "The Effect Of Electric Waves On The Human Brain," by A. F. Collins, published in *Electrical World And Engineer*, Volume 39, Number 8, February 22, 1902, pp. 335-338. ■



# A SUPER-SENSITIVE ALL-WAVE CRYSTAL SET

J. M. NIGHSWANDER

A description of a crystal receiver designed for all-wave reception. This set is an outgrowth of the original set described by the author in our December, 1932 issue. It is especially designed for the man entering the radio field.

**A** SUPER-SENSITIVE all-wave crystal set using plug-in-coils was developed by the writer and described in the December, 1932, issue of RADIO-CRAFT, page 354. Now, a new circuit has been brought out which is much more sensitive and selective than the earlier design. The latest arrangement uses but two plug-in coils (taken from an old S.-W. set), one for each wave band, and there is but one basic change in the circuit. The improved circuit design is shown in Fig. 1.

Using the set with a long antenna and a ground connection, KFI (640 kc.) was the highest possible station to be tuned in. The lower part of the broadcast band and short-wave stations are received with the new set with as much volume and far better selectivity than could be obtained with the old set by using this long outdoor antenna; instead of a ground connection, a 50 ft. indoor antenna is used as a sort of counterpoise. This counterpoise lowers the tuning limit somewhat.

(Other builders of the old circuit report distant reception of air ports and

planes, police, and some S.-W. stations, using about a 60 ft. antenna and a 60 ft. counterpoise and tapping the coil at 3 and 9 turns from the ground end.)

What the set has done: In a few days operation this set has brought in police calls from Seattle, Portland, San Francisco, Berkeley and Denver; air ports in Oregon, Washington, Idaho, Wyoming, Utah, Arizona, Colorado and California, with many 'planes in flight. Heard: Amateur 'phone from half across the U. S. and two S.-W. broadcast stations upon adjacent channels on the night of Feb. 7. (Caught the call of but one at 8:01 P. M. [Pacific time], W3XL, 6,425 kc., 46.96 meters, Bound Brook N. J., playing marimba solo, La Sorrella.) And as for code, some nights it's like a bee hive!

The relative broadness of tuning on this set is an advantage in finding S.W. broadcasts and other voice signals, although, as a crystal set goes, it tunes sharp.

### Building the Set

The coils can be built on celluloid, bakelite, or paper forms 3 ins. in dia.

Use No. 18 or 20 S.G.C. or D.C.C. wire, spaced about 18 turns to the inch.

The large coil, L2, in Fig. 1, has 54 turns, tapped, from the ground end, at 6, 15, 27, and 40 turns. This coil goes far below the broadcast band. For the real short-wave band the coil L2 should have 15 turns, tapped at 3, 6, 9, and 12 turns from the ground end. This coil, using a counterpoise, goes up into the broadcast band and separates stations better, with good volume, than the large coil. It is not known how far this coil will tune below 46.96 meters.

Coil L1, the untuned, fixed, 11-turn primary, is made in the general manner described for coils L2; coil L1 must be made just small enough to slip inside and at the ground end of either of the coils which are used as L2. (This primary is not a very important winding and is used but little, although, if loosely coupled when using a ground, it results in increased selectivity on loud signals.)

The same station will come in on several taps, but use the one which places the station lowest on the tuning (Continued on page 587)

## THE RADIO BEGINNER

• In this department we shall print every month simple, but effective radio sets and circuits, and other information for radio beginners, or those just starting in radio. There are thousands of radio fans and experimenters who are still interested in building their own, and

in experimenting with home-made sets. The new instruments, as well as the new tubes, make this endeavor of particular importance.

If you build the sets described in these pages, won't you be good enough to advise us what results you are getting?

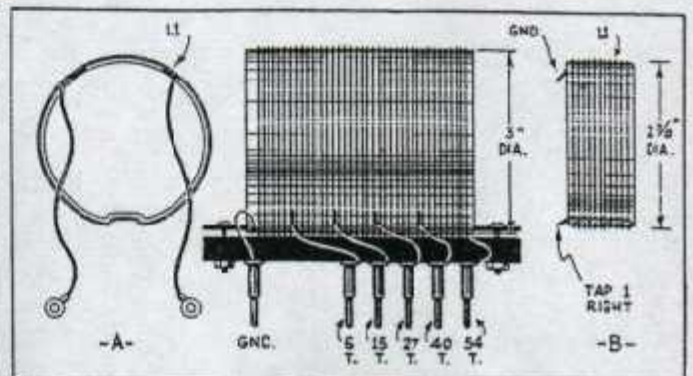
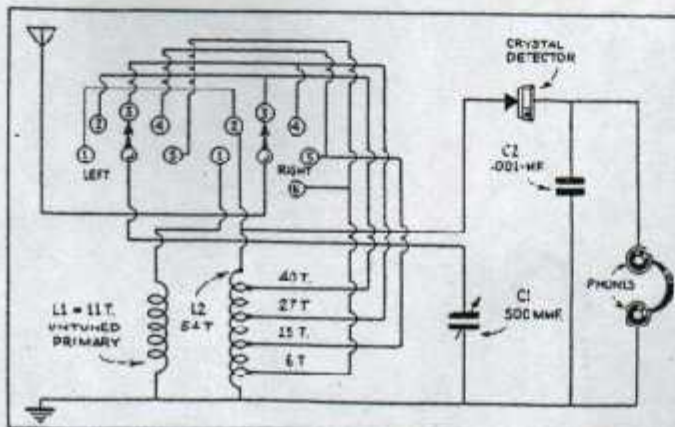

Fig. 1, left. Schematic circuit of the receiver described. Fig. 2, above. Sketch of the tuning coil. Two coils are needed to cover both the broadcast and short-wave bands.

appears in Fig. Q.197. A front-view illustration of the instrument is Fig. Q.197A.

## A SUPER SENSITIVE ALL-WAVE CRYSTAL RECEIVER

(Continued from page 680)

condenser setting for loudest signals.

To tune to the higher frequencies, move the right-hand switch (marked "right" in Fig. 1) forward, clockwise, one to three taps before advancing the left-hand switch arm. The efficiency of this set seems to lie partly in the low-loss coils, but mostly in the one basic change in the circuit, in which the detector is connected permanently to the last turn (from ground) on the tapped coil.

### List of Parts

- One Puretone or Rotozit crystal detector (or a good piece of galena)
- One tuning condenser, 500 mmf., C1;
- One fixed condenser, .001-mf., C2;
- One set of coils (see text) L1, L2;
- One pair of headphones (Baldwin, Brandes, etc.);
- Two tap switches, "left," "right";
- Eleven taps;
- One baseboard, 7 x 12 x  $\frac{1}{8}$ -in.;
- One panel, 7 x 7 x  $\frac{1}{4}$ -in.;
- Hookup wire, screws, etc.

Ce

Thousan  
doing si  
icemen  
factory  
course, a  
Send  
stationer

C

CENT  
930 E.



## How to Put the Sun to Work

The radio set described below is only the first in a series of projects which will show you how to have fun tapping power from the sun. Also in this issue are plans for building a sun battery, which can be used to power a small motor. Subsequent issues will show you how to construct and use other solar-powered projects, such as a sun-controlled relay or light switch and perhaps a more powerful radio.

If you want to carry your experiments with sun-power still further, let us know what projects you would like to see, and we'll try to develop and publish them for you.

# Sun-Powered RADIO

By  
HAROLD P. STRAND

IF WE can make the air we breathe carry radio programs to us, why not let sunlight power the receiver which captures those radio waves for our entertainment? Research laboratories have originated and developed radio receivers which operate on sunlight. Now, at last, you can do the same, without being an engineering genius or having a miniature for-



Testing the completed receiver, under (1) sunlight and (2) a 100 watt lamp. Direct sunlight naturally gives you much stronger reception.



### Craft Print Project No. 248

tune to spend.

For example, you can build the radio set shown in Fig. 1 for about \$11-12 in materials—a small investment considering the fun you will get from it. It is a pocket-size portable, requires no conventional dry cells for power, and it doesn't even need an On-Off switch. Simply holding your hand over the selenium photocells which capture the sunpower, will shut off or tone way down



## How Selenium Photocells Convert Sun Power

IN DESIGNING sun-powered projects like the radio shown in Fig. 1, you can convert sunlight into electricity using selenium photocells. These are relatively low cost and easy to obtain, but convert at best only about 1% of the light striking them into electrical power. Another method would be to use silicon cells, which are somewhat costly. Their advantage is that they are about 11% efficient. Bell Telephone Labs, for instance, uses 100 silicon cells mounted in a glass-covered case on a telephone pole, to power an experimental telephone line in Georgia.

For this radio project, we used selenium cells, because they will do the job nicely and you can get them easily at a moderate price. Fig. A shows a simplified sectional view of one of these cells, correctly called selenium barrier-layer, self-generating photoelectric cells. The light which hits it penetrates the transparent front electrode and causes the selenium to release electrons. These released electrons travel across the barrier layer and are trapped on the front electrode to form a negative charge. (The unilateral conductivity of the barrier layer prevents the electrons from returning, except for some small leakage.) The

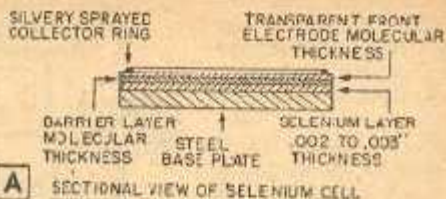

negative charge on the front electrode is in turn transmitted to the collector ring. This ring then becomes the negative, and the base plate the positive terminal of the cell.

When these two terminals are connected to the actuating device or amplifier, current of about 600 microamps per lumen will flow, at an external resistance of 100 ohms. Therefore, in such a cell, we have a source of d-c current similar to a dry cell, which can be connected in groups with other similar cells in series, parallel, or series-parallel, to obtain the desired voltage and current output.

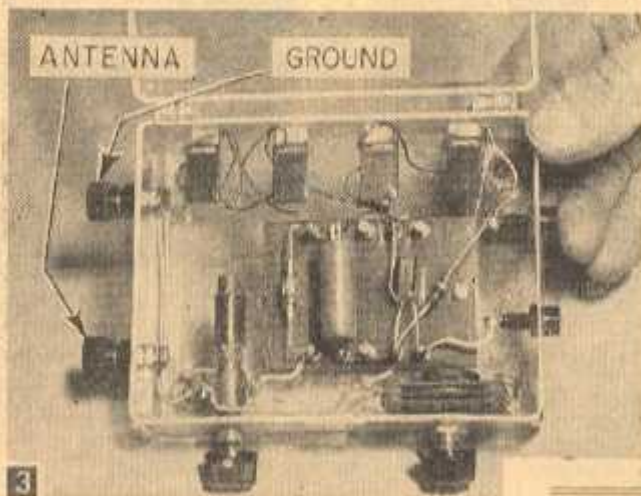

Closeup of radio with lid of plastic case up.

those objectionable commercials. On cloudy days or at night, you can operate the set by shining a 100 to 150 watt light bulb on the photocells—thanks to the low load requirements of the tiny transistor used in this set. However, do not allow temperature in excess of 185°F on the cells or they may be damaged. In other words keep light bulb back a foot or more for prolonged operation. An explanation of why we chose the B2M type photocells for this project, and how they convert sunlight into electrical power is given in the box copy at the top of this page.

**Constructing the Radio.** As Figs. 3-6 show, this pocket-size radio has a diode detector and transistor amplifier built into a standard plastic case. In place of the dry cell usually used for power, four B2M photocells which will not need replacing are mounted on the back side of the case. Drill all the mounting holes in the plastic case as shown in Fig. 7, and in turn, mount the diode, capacitor, resistor and transistor to the

terminal board.

Mount phone jacks and ground and antenna terminals, as well as the #MS215 miniature tuning condenser, and the ferrite-core tuned antenna coil, into their respective positions in the plastic case as shown in Figs. 3 through 8.

For the next step, attach the cell brackets to the back of the case with machine screws and nuts as shown in Figs. 6 through 8.

These B2M cells cost from \$1.47 to \$2.50 each (depending on where you buy them). They measure .040 x .443 x .724 in., have an active area of .26 in., and are rated at .5 volt open-circuit voltage, 2 milliamperes with

### MATERIALS LIST—SUN RADIO

- 1 plastic case with hinged cover  $1\frac{1}{2} \times 2\frac{1}{2} \times 4\frac{1}{2}$  in. inside measurements (Lafayette Radio, 110 Federal Street, Boston, Mass., or 100 Sixth Avenue, New York, N. Y. Cat. #MS 162, \$0.32).
- 4 International Rectifier Corp. B2M photocell sun batteries (Lafayette Radio or Allied Radio, 100 N. Western Avenue, Chicago 80, Illinois. About \$1.47 each).
- 1 antenna coil with adjustable high Q core for broadband range 540-1700 kc. (Lafayette or Allied Radio).
- 1 Sylvania crystal diode 1N34A (Lafayette or Allied Radio).
- 1 1-mfd. electrolytic condenser 50 volt, Cornell-Dubilier B5R-1-50 or equivalent. (Allied Radio.)
- 1 250,000, 1 meg.  $\frac{1}{2}$  watt resistor (Lafayette or Allied Radio).
- 1 Raytheon CK 722 transistor (Lafayette or Allied Radio).
- 1 355 miniature tuning condenser (Lafayette Radio Cat. #MS 215, \$0.69).
- 2 phone to jacks (Allied Radio Cat. #41 H 115, \$0.12 each).
- 2 insulated binding posts (Allied Radio Cat. #41 H 350 Euy Type 93, each \$0.21).
- 4 rubber feet knobs  $\frac{1}{2}$ " diameter, no screws (any local radio supply store).
- 1 terminal board with 5 terminals for solder tabs from old electronic surplus equipment or make up).
- 1 small Bakelite knob to fit condenser shaft.
- 1 small Bakelite knob that can be bushed and threaded to fit coil shaft, (Lafayette Radio MS-185 \$0.07).

#24 hook-up insulated wire, screws, nuts, etc.



a 10 ohm load, and a power output of .3 milliwatts with a 100 ohm load, when used in average sunlight. Under artificial light or with lower intensity natural daylight, the ratings will of course be lower, though the set will still work well if other conditions are favorable.

Complete the wiring of the mounted components as shown in Figs. 3 through 5, soldering all connections and keeping the leads as short as possible. Cementing four rubber knobs to the bottom of the case at the four corners will raise the case up enough to provide clearance for the nuts securing the terminal board.

**Testing the Receiver.** With the wiring completed, attach an antenna wire about 25 ft. long, and clip a ground wire to a grounded light fixture, heating pipe, radiator, plate screw on a wall outlet, or finger clip on a dial phone. In some rural areas far removed from radio stations, an outside antenna about 100 ft. long may be needed to bring the stations in well. For headphones, use the common magnetic type of 2,000 ohm or higher resistance.

Plug in earphone jacks and hold radio so strong sunlight shines on photoelectric cells. Reception should start immediately and you can tune radio by turning both the tuning condenser knob and antenna coil knob to get the strongest

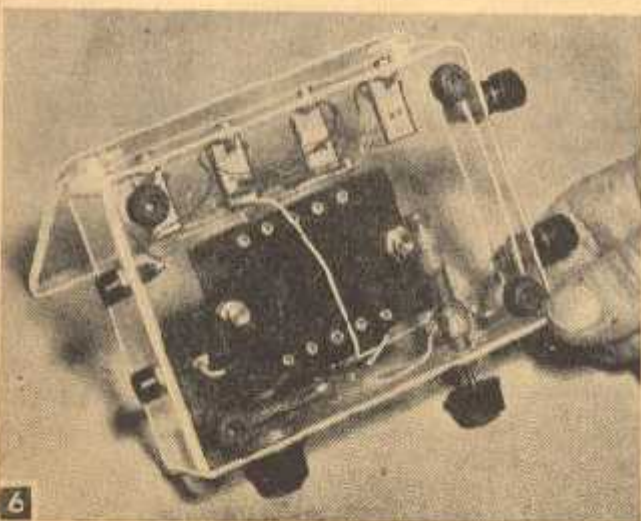
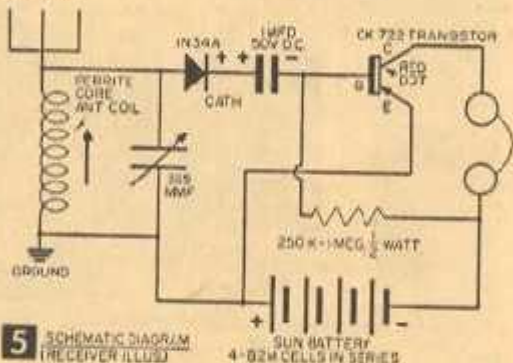
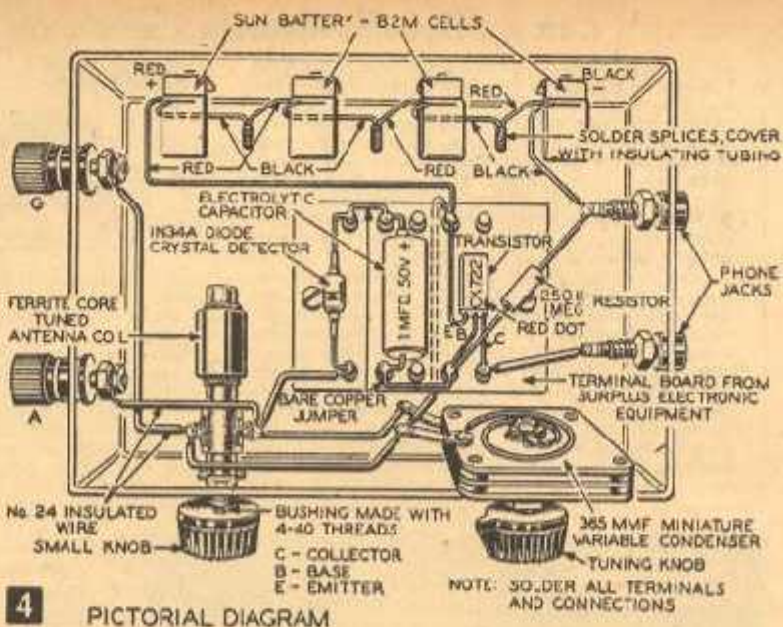

**6** View from underside of terminal board. Note mounting of four cells with the brackets furnished against back of plastic case.

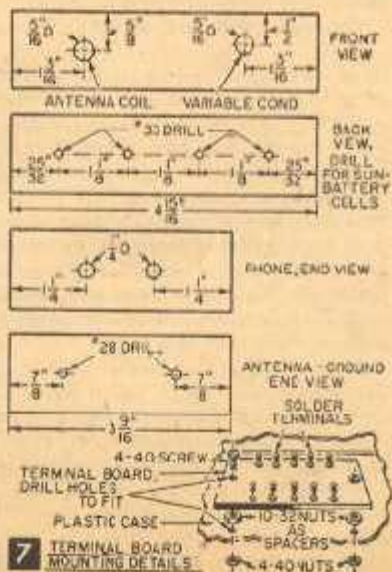



and clearest signals, and separate the stations.

If you are located in a steel-framed building in a large city close to the broadcasting stations, don't expect top-notch performance from this set. Like the crystal set designs from which this is adapted, you won't get the maximum sensitivity and selectivity under such conditions. So take the set out to your Cousin Emma's house in the suburbs if you really want to see what it will do.

**Indoor Light Test.** As Fig. 9 shows, we conducted a test of current output with a 0-1 milliammeter under a 100-watt lamp. Clip leads attached to the battery terminals show a .5 milliampere current, with the light source about 8-10 in. above the cells. Under sunlight, this reading would be around 2 milliamperes. (When using a lamp to activate the cells, remember not to let the hot bulb stay close to cells for long periods of time, since heating cells over 185°F will injure them).

Figure 10 shows a test of the radio, using a high resistance voltmeter (20,000 ohms per volt), which places a very light load on the cells. With this setup, and still using a 100 watt

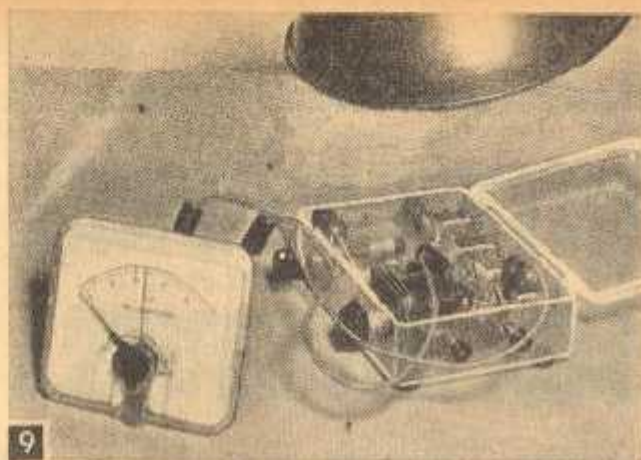

9 With a 100 watt lamp for illumination, a current of .5 milliamperes was generated by the photocells. In good sunlight, this would be around 2 ma. more or less, depending on the individual cells.

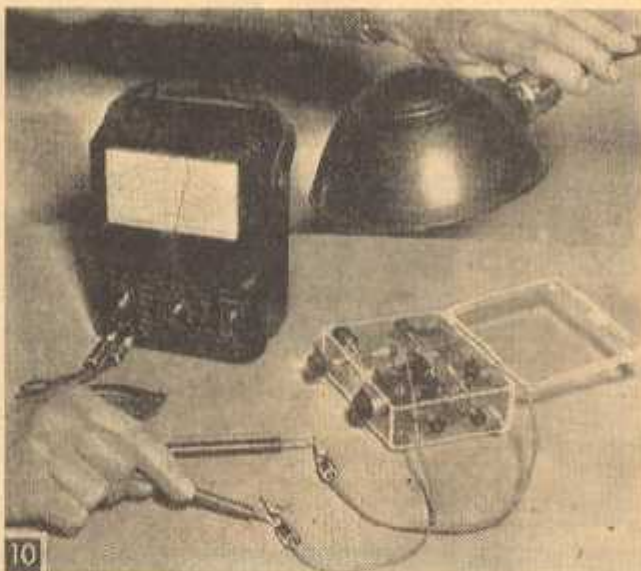

10 Voltage across the cells in a test with a high resistance voltmeter was 1.4 volts.

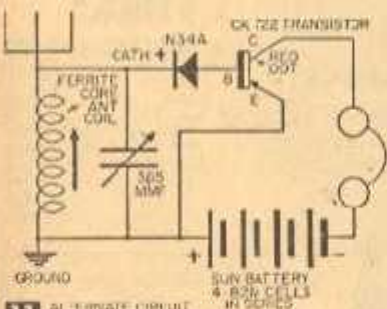

11 ALTERNATE CIRCUIT FOR EXPERIMENT

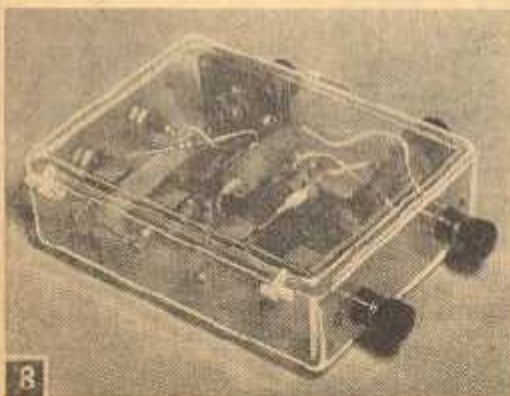

8 View from rear with plastic lid closed. Insulated terminal posts are used for the antenna and ground.

light bulb, we got a reading of about 1.4 volts across the battery.

The circuit shown is only one of many you could use—just so long as your circuit does not require more than 1½-3 volts normally from a dry cell. Figure 11 shows another type of circuit you might want to try out—if you are in an experimenting mood.

Some other circuits can be tried that might prove to be more selective and sensitive for areas where this may be desirable. If you have luck in developing them, let us hear about it.

● Craft Prints in enlarged size for building sun-power radios are available at 50¢ each. Order by print number, enclosing remittance (no C.O.D.'s or stamps) from Craft Print Dept., SCIENCE AND MECHANICS, 450 East Ohio Street, Chicago 11, Illinois.

Sept. 3, 1957

K. L. BELL

2,805,332

SUBMINIATURE PORTABLE CRYSTAL RADIO RECEIVER

Filed Jan. 20, 1955

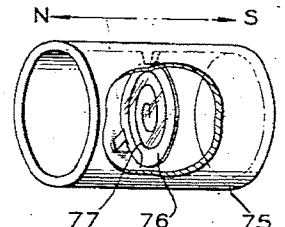
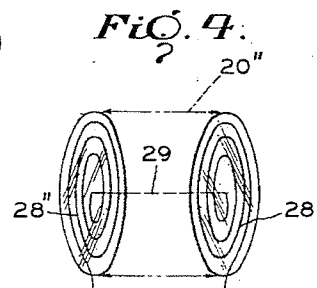
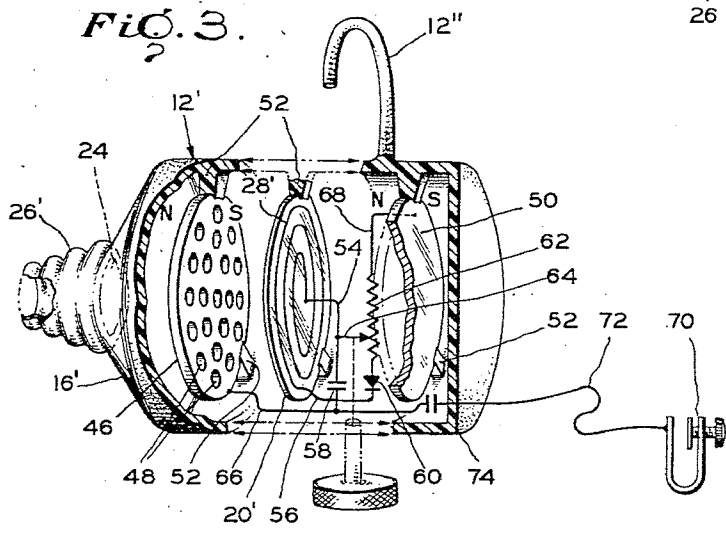
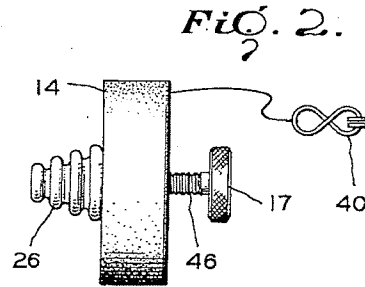
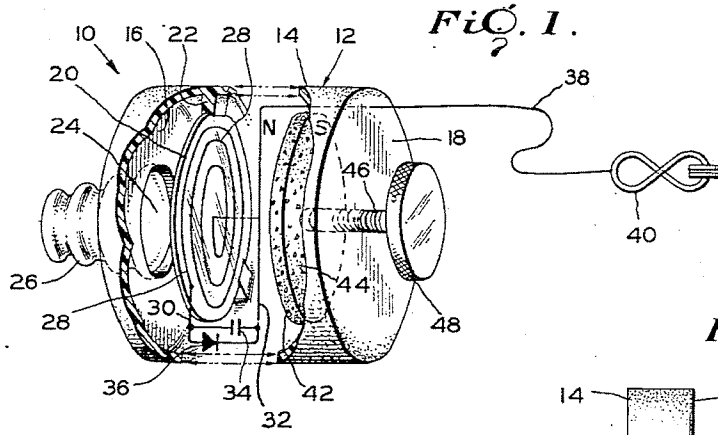

INVENTOR  
*Keith L. Bell.*  
 BY *Justus Miller.*  
 ATTORNEY

1

2

2,805,332

**SUBMINIATURE PORTABLE CRYSTAL RADIO RECEIVER**

Keith L. Bell, Washington, D. C., assignor of one-half to  
Gustave Miller, Washington, D. C.

Application January 20, 1955, Serial No. 483,103

19 Claims. (Cl. 250—20)

This invention relates to radio receivers, and more particularly to a radio receiver of the subminiature type adapted to be carried or worn on the person of the user.

Many types of small portable radio receivers have been devised, some of which include battery power supplies and vacuum tube detecting and amplifying means, and others of the crystal detector type and without batteries or amplifying means. The receivers of the type including batteries have in general been cumbersome and too large in size to be conveniently carried or worn on the person. Prior receivers of the crystal detector type without batteries or amplifying means have been unable to deliver sufficient volume to prove satisfactory to the user, even when turned to a powerful transmitter a few miles distant.

There is a real need in many fields for a small miniature radio receiver adapted to be worn or carried on the person. In the military services, and in civil defense work, for example, such receivers would have widespread use for transmitting intelligence to soldiers or civil defense workers. Miniature radio receivers adapted to be plugged into the ear, for example, could also find great utility in connection with public activities, such as football games, in which spectators equipped with such radio receivers could receive a running description of the game to supplement their visual impressions.

Accordingly, it is an object of this invention to provide a radio receiver of the subminiature type which provides a strong clear signal without requiring the use of batteries or amplifying means, such as vacuum tubes or transistors.

It is a further object of this invention to provide a radio receiver of the subminiature type which is light in weight and inexpensive to manufacture.

In achievement of these objectives, there is provided in accordance with this invention a miniature radio receiver of the crystal detector type in which an inductive tuning winding is carried by the diaphragm member which produces the sound waves, the audio frequency currents produced by the rectifying action of the crystal detector passing through the inductive winding and reacting with a permanent magnet field to provide a dynamic speaker action. The powdered magnetized metal forming the permanent magnet field, in addition to providing a dynamic speaker action by its reaction with the audio frequency current passing through the inductive winding also provides permeability tuning of the radio frequencies in the inductive winding. In one embodiment of the invention, the permanent magnet field means is adjustably spaced with respect to the inductive winding to permit tuning the receiving circuit to a desired frequency. In another embodiment of the invention, the permanent magnet field remains fixed with respect to the inductive winding, the spacing of the permanent magnets with respect to the inductive winding being such as to provide resonance at a predetermined frequency. The permanent magnet field is preferably provided by magnetically oriented permanent magnet particles held in a binder or holder of non-metallic plastic or ceramic material.

Further objects and advantages of the invention will become apparent from the following description taken in conjunction with the accompanying drawings in which:

Fig. 1 is a perspective view, partially diagrammatic and schematic, of a miniature radio receiver in accordance with one embodiment of the invention;

Fig. 2 is a side elevation view of the radio receiver of Fig. 1;

Fig. 3 is a perspective view, partially diagrammatic and schematic, and with the casing broken away, of a modified radio receiver in accordance with the invention;

Fig. 4 is a side elevation view of a modified type of diaphragm having an inductance carried by both surfaces of the diaphragm; and

Fig. 5 is a side elevation view of a still further modified type of receiver in which the permanent magnet field is in the form of a hollow tubular member which surrounds the inductive tuning winding.

Referring now to the drawing, and more particularly to Figs. 1 and 2, there is shown a subminiature radio receiver generally indicated at 10 and comprising a casing or housing 12 preferably formed of plastic or other dielectric material and including a body portion 14, which may be generally cylindrical in shape, and end walls 16 and 18. Disposed within casing 12, and preferably lying in a plane generally parallel to end walls 16 and 18, is a very thin dielectric disk member 20. Disk 20 is disposed adjacent but spaced from end wall 16 and is supported with respect to casing 12 by a suitable retaining means indicated at 22. End wall 16 is provided with an aperture 24 located on the longitudinal axis of housing 12, and a hollow, sound conducting ear plug 26, formed of rubber or other suitable material, is connected over aperture 24.

An inductive winding 28 in the form of an electrically conductive non-magnetic spiral is positioned on one surface of disk 20, winding 28 preferably being positioned on the disk by any of the well known methods of printed circuitry and becomes magnetic only when current is flowing in it. The two ends of winding 28 are connected by conductors 30 and 32 to opposite sides of a germanium diode detector 36. A radio frequency by-pass condenser 34 is connected in parallel with detector 36 across conductors 30 and 32. The use of by-pass condenser 34 is optional, but the condenser is preferably employed to minimize any tendency of the unrectified radio frequency current components to block the crystal detector 36. This tendency to block occurs particularly at very high radio frequencies, such as those encountered in frequency modulation reception. This by-pass capacitor also partially tunes the spiral inductance. One end of winding 28 is also connected by means of a conductor 38 to a metallic ear clip 40 which is positioned exteriorly of casing 12 and is adapted to be clipped onto the ear of the user to permit the body of the user to serve as an antenna.

Disposed adjacent disk 20 but in spaced relation thereto is a disk 42 made of plastic or other suitable dielectric material. Embedded in disk 42 are powdered metal particles 44 which are permanently magnetized in the direction N-S, preferably along an axis perpendicular to the plane of disk 20 and inductance 28. Disk 42 is mounted on and carried by a threaded rod or shaft 46 which passes through a threaded bearing in end wall 18 of the housing. A knurled operating knob 48 is connected to the outer end of rod 46 exteriorly of the housing.

In using the radio receiver shown in Figs. 1 and 2, the user inserts ear plug 26 in his ear, and fastens ear clip 40 to an ear lobe. The connection of ear clip 40 to the ear lobe provides an antenna connection to the tuning circuit comprising spiral inductive winding 28 with the listener's body serving as an antenna. Tuning to the desired frequency is accomplished by turning knob 48

to rotate shaft 46 and thus move disk 42 axially with respect to disk 20 and winding 28. Movement of disk 42 with respect to winding 28 changes the inductance value of winding 28 due to the change in the spacing of the ferrous particles 44 with respect to the winding 28, thereby varying the frequency to which the circuit is tuned.

Diode detector 36 rectifies the radio frequency signal and produces audio frequency currents in accordance with the audio modulation of the radio frequency carrier. These audio frequency currents flow through winding 28 and produce a magnetic field which reacts with the permanent magnet field produced by ferromagnetic particles 44 in disk 42. The reaction of these two magnet fields with each other provides a dynamic speaker action which vibrates disk 20 and produces sound waves. These sound waves pass through aperture 24 in end wall 16 and through plug 26 to the ear of the listener.

Volume control is obtained in the embodiment of Fig. 1 by adjusting disk 42 to be just slightly off the position which produces peak resonance in the tuning circuit.

The radio receiver herein before described will receive amplitude modulated radio signals and will also satisfactorily receive frequency modulated broadcasts which are modulated by voice frequencies or other frequency modulated signals of a relatively narrow range of modulation.

The embodiment shown in Fig. 3 includes a housing 12' made of plastic or other suitable material and an ear plug 26' both generally similar to those described in the embodiment of Fig. 1. Positioned with housing 12' substantially centrally of the longitudinal axis thereof, and perpendicular to that axis, is a very thin dielectric disk 20' having positioned on a surface thereof substantially perpendicular to the longitudinal axis an inductive winding 28', both the disk 20' and winding 28' being similar to those previously described in connection with the embodiment of Fig. 1. A hook 12'' which is part of the casing 12' is provided to loop over the ear to support the radio receiver.

Positioned within casing 12' adjacent the end wall 16' to which ear plug 26' is connected and in spaced relation to disk 20' is a highly magnetized thin metal disk 46 having numerous perforations 48 therethrough. Disposed on the other side of disk 20' and in spaced relation thereto is a thin solid metal disk 50 which is also highly magnetized. Disks 20', 46 and 50 are supported with respect to housing 12' by suitable supports indicated at 52.

The opposite ends of winding 28' on disk 20 are connected by conductors 54 and 56 to the opposite sides of a radio frequency by-pass capacitor 58. One side of a germanium diode or other suitable solid state detector 60 is connected to conductor 56 and thus to one side of capacitor 58 and to one end of winding 28'. The other side of germanium diode detector 60 is connected to the stator 62 of a volume control resistor. The rotor 64 of the volume control resistor is connected to conductor 54 and thus to one side of capacitor 58 and to one end of winding 28'. Rotor 64 projects through the casing 12 to the exterior of the casing where it is accessible for manual operation.

In order to utilize the capacitance between disks 46 and 50 in the tuning circuit, disk 46 is connected by conductor 66 to conductor 56 and thus to one end of winding 28'. Disk 50 is connected by conductor 68 to one end of the stator resistor 62 of the volume control and thence through rotor 64 to the opposite side of winding 28'. Thus, the capacitance between plates 46 and 50 is connected in parallel with winding 28'. Disks 46 and 50 serve as permeability tuners due to the fact that they are formed of magnetic material and thus affect the inductance of winding 28'. In the embodiment shown, disks 46 and 50 are fixed with respect to winding 28', thereby causing the inductive tuning circuit to be resonant

at a fixed frequency. However, obviously, disks 46 and 50 could be made movable with respect to spiral winding 28', thereby permitting tuning to different frequencies. Also, the disks 46 and 50 could be of the type shown in Fig. 1 in which permanently magnetized ferrous particles are embedded in a dielectric material.

An ear clasp 70 having a screw threaded clamping element for engagement with the ear lobe of the listener is disposed exteriorly of casing 12'. Ear clasp 70 is connected to the tuned circuit by conductor 72. An antenna coupling capacitor 74 is connected in series with conductor 72 between ear clasp 70 and the very sensitive detector 60. When ear clasp 70 is connected to the ear lobe of the listener, the body of the listener then serves as an antenna and is connected to the tuning circuit.

The audio modulations of the radio frequency carrier are detected and rectified by germanium diode detector 69. The rectified audio currents pass through conductive spiral 28' on dielectric disk 20 and react with the permanent magnet field of magnetized disks 46 and 50. Disk 20' then vibrates as a dynamic speaker element to produce sound waves which pass through the perforations 48 of disk 46 and thence through aperture 24' and ear plug 26' to the ear of the listener.

The capacitance and permeability inductance values of the embodiment of Fig. 3 preferably remain fixed, so that the receiver remains tuned to a single predetermined frequency. Volume control is obtained by adjustment of the rotor 64 of the resistor, rotor 64 being accessible to the listener from the exterior of the casing.

As shown in Fig. 4, the conductive spirals 28 and 28' on the disks 20 and 20' may be positioned on both major surfaces of the disk. When this is done, the two conductive spirals 28'' are connected in series with each other, as, for example, by a conductor 29 passing through the disk 20'.

As shown in Fig. 5, the permanent magnet field may be provided by a permanently magnetized hollow tubular member 75 of magnetic material which surrounds the dielectric disk 76 on which the inductive winding 77 is positioned. Tubular member 75 may be of plastic containing magnetized particles. Disk 76 is disposed within the magnetized tube 75 substantially midway of the length of the tube. Tube 75 is preferably magnetized along its longitudinal axis, so that one end is a north pole and the opposite end is a south pole. Winding 77 is connected to a solid state rectifier, such as a germanium rectifier, as previously described. Winding 77 is also provided with an antenna connection such as those previously described. The rectified audio component of the radio frequency signal passes through winding 77 and sets up a magnetic field which reacts with the magnetic field provided by the permanently magnetized tubular member 75. The reaction of the two fields causes a vibration of the disk 76 to provide a dynamic speaker action.

It can be seen from the foregoing that there is provided in accordance with this invention a miniature radio receiver which is simple in construction and economical to manufacture and sell. The radio receiver requires no batteries for its operation, and provides a dynamic speaker action due to the position of the current carrying inductive winding on the diaphragm member relative to the permanent magnet field.

While there have been shown and described particular embodiments of the invention, it will be obvious to those skilled in the art that various changes and modifications may be made therein without departing from the invention, and, therefore, it is aimed to cover all such changes and modifications as fall within the true spirit and scope of the invention such as the employment of three or four contact germanium elements instead of the dual contact detector element shown. Furthermore, if desired a silicon strip sun operated battery could be employed with this invention where amplification is desirable. A still further modification may be employed wherein the detected audio



currents may be employed to power a signal amplifying transistor in accordance with this invention.

Having thus set forth and disclosed the nature of this invention, what is claimed is:

1. A subminiature radio receiver comprising a casing, a thin diaphragm of dielectric material disposed within said casing and inductive tuning winding carried by said diaphragm for receiving a radio frequency signal, means for providing a low reluctance permanent magnet field having low core losses at radio frequencies adjacent said winding, and means connected in circuit with said winding to detect an audio frequency component of a radio frequency signal and feed said audio frequency back to said tuning winding, said audio frequency component reacting with said permanent magnet field to dynamically reproduce audible sound.
2. A subminiature radio receiver comprising a casing, a thin diaphragm of dielectric material disposed within said casing, an inductive tuning winding carried by said diaphragm, a low reluctance permanent magnet field means having low core losses at radio frequencies disposed in said casing adjacent said winding, and means connected in circuit with said winding to detect an audio frequency component of a radio frequency signal and feed said audio frequency component back to said tuning winding, said audio component co-acting with said permanent magnet field to dynamically vibrate said diaphragm according to said audio component.
3. A miniature radio receiver as defined in claim 2 in which said magnet field means is adjustably movable with respect to said winding to vary the resonant frequency of said tuning winding.
4. A miniature radio receiver as defined in claim 2 in which said magnet field means is disposed on opposite sides of said inductive winding.
5. A miniature radio receiver as defined in claim 2 in which said magnet field means is in fixed spaced relation to said winding whereby said winding remains tuned to a predetermined fixed frequency.
6. A miniature radio receiver comprising a casing, a thin diaphragm of dielectric material disposed within said casing, an inductive tuning winding carried by said diaphragm and adapted for connection to an antenna means for receiving a radio frequency signal, means for providing a permanent magnet field having low core losses at radio frequencies adjacent said winding, and means connected in circuit with said winding to detect an audio frequency component of said radio frequency signal and feed said audio frequency component back to said tuning winding.
7. A miniature radio receiver comprising a casing, a diaphragm of dielectric material disposed within said casing, an inductive tuning winding carried by said diaphragm for receiving a radio frequency signal, a low reluctance permeability tuning means having low losses at radio frequencies disposed within said casing adjacent said winding, and means connected in circuit with said winding to detect an audio frequency component of said radio frequency signal and feed said audio frequency component back to said tuning winding.
8. A miniature radio receiver comprising a casing, a diaphragm of dielectric material disposed within said casing, an inductive tuning winding carried by said diaphragm and adapted for connection to an antenna means for receiving a radio frequency signal, a low reluctance permeability tuning means having low losses at radio frequencies disposed within said casing adjacent said winding, said permeability tuning means being adjustably movable with respect to said winding to vary the resonant frequency of said winding, and means connected in circuit with said winding to detect an audio frequency component of said radio frequency signal and feed said audio frequency component back to said tuning winding.
9. A miniature radio receiver comprising a casing, a

- diaphragm of dielectric material disposed within said casing, an inductive tuning winding carried by said diaphragm for receiving a radio frequency signal, a permanently magnetized permeability tuning means having low losses at radio frequencies disposed within said casing adjacent said winding, and means connected in circuit with said winding to detect an audio frequency component of said radio frequency signal and feed said audio frequency component back to said tuning winding.
10. A miniature radio receiver comprising a casing, a thin diaphragm of dielectric material disposed within said casing, an inductive tuning winding carried by said diaphragm and adapted for connection to an antenna means for receiving a radio frequency signal, permanent magnet means having low losses at radio frequencies disposed in said casing adjacent said winding, and means connected in circuit with said winding to detect an audio frequency component of said radio frequency signal and feed said audio frequency component back to said tuning winding.
11. A miniature radio receiver comprising a casing, a thin diaphragm of dielectric material disposed within said casing, an inductive tuning winding carried by said diaphragm, means disposed in said casing for providing a low reluctance magnetic field adjacent said winding having low losses at radio frequencies, and solid state rectifier means connected in circuit with said winding to detect an audio frequency component of a radio frequency signal and feed said audio frequency component back to said tuning winding.
12. A miniature radio receiver comprising a casing, a diaphragm of dielectric material disposed within said casing, an inductive tuning winding carried by said diaphragm for receiving a radio frequency signal, a magnetic permeability tuning means having low losses at radio frequencies disposed within said casing adjacent said winding, and a solid state rectifying means disposed within said casing and connected in circuit with said winding to detect an audio frequency component of said radio frequency signal and feed said audio frequency component back to said tuning winding.
13. A miniature radio receiver comprising a casing, a diaphragm of dielectric material disposed within said casing, an inductive tuning winding carried by said diaphragm and adapted for connection to an antenna means for receiving a radio frequency signal, magnet means having low losses at radio frequencies disposed within said casing adjacent but spaced from said diaphragm, means for varying the spacing of said magnet means from said winding, and means connected in circuit with said winding to detect an audio frequency component of said radio frequency signal and feed said audio frequency component back to said tuning winding.
14. A miniature radio receiver comprising a casing, a diaphragm of dielectric material disposed within said casing, an inductive tuning winding carried by said diaphragm and adapted for connection to an antenna means for receiving a radio frequency signal, permanent magnet means disposed in said casing adjacent said winding, said magnet means including a plurality of similarly oriented magnetic particles embedded in a non-magnetic holding means, and means connected in circuit with said winding to detect an audio frequency component of said radio frequency signal and feed said audio frequency component back to said tuning winding.
15. A miniature radio receiver as defined in claim 14, in which said magnet means is adjustably movable with respect to said winding to vary the resonant frequency of said tuning winding.
16. A miniature radio receiver as defined in claim 14 in which said magnet means is disposed on opposite sides of said inductive winding.
17. A miniature radio receiver as defined in claim 14 in which said magnet means is in fixed spaced relation to said winding whereby said winding remains tuned to a predetermined fixed frequency.



18. A miniature radio receiver comprising a casing, a diaphragm of dielectric material disposed within said casing, an inductive tuning winding carried by said diaphragm and adapted for connection to an antenna means for receiving a radio frequency signal, a generally hollow cylindrical permanent magnet member disposed within said casing, said diaphragm being positioned within the hollow interior of said magnet member, and means connected in circuit with said winding to detect an audio frequency component of said radio frequency signal and feed said audio frequency component back to said tuning winding.

19. A miniature radio receiver comprising a casing, a diaphragm of dielectric material disposed within said casing, an inductive tuning winding carried by said diaphragm and adapted for connection to an antenna means for receiving a radio frequency signal, a generally hollow cylindrical permanent magnet member disposed within said casing, said diaphragm being positioned within the

hollow interior of said cylindrical magnet member in a plane substantially perpendicular to the longitudinal axis of said magnet, and means connected in circuit with said winding to detect an audio frequency component of said radio frequency signal and feed said audio frequency component back to said tuning winding.

## References Cited in the file of this patent

## UNITED STATES PATENTS

314,156	Taylor	Mar. 17, 1885
407,799	Trowbridge et al.	July 30, 1889
1,219,888	Wallberg	Mar. 20, 1917
1,687,371	Leeper	Oct. 9, 1928
2,554,270	Rosenberg	May 22, 1951
2,576,679	Guillaud	Nov. 27, 1951

## FOREIGN PATENTS

204,663	Great Britain	Oct. 4, 1923
---------	---------------	--------------

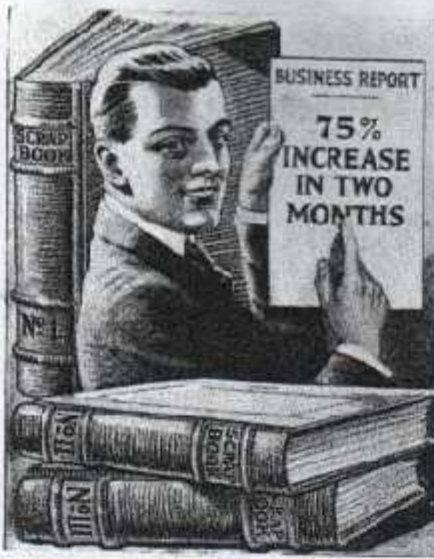

A New Jersey student writes:

"I have purchased a business and by the use of methods explained in my course have increased the business 75 per cent. in two months." This is just one extract from.

### Three Big Scrap-Books

filled with appreciative, interesting letters from young men throughout the United States—all received recently. They show a national recognition of the unique features of the

### United Y. M. C. A. Courses and Correspondence-Teaching Methods

The limited space permits only a few additional extracts. "You bring out a man's resources."—California student. "I like your personal service."—Missouri student. "You take an interest in each student individually."—Connecticut student. "You remind me of a great teacher—always ready to lend a helping hand."—Another Connecticut student. "Too much cannot be said for Y. M. C. A. instruction service."—Illinois student. "Course instructs through training. Am able to use the instruction in my regular work."—Ohio student. "You seem to read every single word of my answers and even catch my pen-errors."—Massachusetts student. "Course did me more good than the course I took in college."—N. Carolina student. "If a man knows no so anything at all, your system will bring it out."—Texas student. "My course has not only brought more interesting work, but multiplied my earning power by three."—Nebraska student. "Have been doing practical advertising lately and received favorable comments on it from our manager."—N. Dakota student.

### Send for the "Six Reasons"

why these ambitious young men and thousands of others have selected the United Y. M. C. A. Schools to guide them in their preparation for greater personal development, more responsibility, more congenial work or better paying work. Our friendly counsel is free.

UNITED Y. M. C. A. SCHOOLS  
Dept. 64-A, 325 Lexington Ave.,  
New York City



I am interested in United Y. M. C. A. Schools' service. Please give me free counsel as to the position or home-study course I have marked.

- |   |   |
|---|---|
| <ul style="list-style-type: none"> <li>..Accountant</li> <li>..Advertising Man</li> <li>..Agricultural Courses</li> <li>..Aviation</li> <li>..Auto Mechanic</li> <li>..Banking</li> <li>..Better Letters</li> <li>..Bookkeeper</li> <li>..Building Construction</li> <li>..Business English</li> <li>..Business Law</li> <li>..Business Organization</li> <li>..Civil Engineer</li> <li>..Civil Service</li> <li>..Concrete Engineer</li> <li>..Dairy Farming</li> <li>..Draftsman</li> <li>..Electrician</li> <li>..Electrical Engineer</li> <li>..English Course</li> <li>..Factory Management</li> <li>..Farm Management</li> <li>..Farm Motor Mechanic</li> </ul> | <ul style="list-style-type: none"> <li>..Foremanship</li> <li>..Highway Engineering</li> <li>..Locomotive Operator</li> <li>..Machine-Shop Practice</li> <li>..Mathematical Courses</li> <li>..Mechanical Engineer</li> <li>..Plumber</li> <li>..Poultry Husbandry</li> <li>..Radio Operator</li> <li>..Radio Engineer</li> <li>..Railroad Engineering</li> <li>..Salesman</li> <li>..Scherdial</li> <li>..Sherband and Typewriting</li> <li>..Steam Engineer</li> <li>..Structural Drafting</li> <li>..Surveyor</li> <li>..Textile Designing</li> <li>..Traffic Management</li> <li>..Use of the Slide Rule</li> </ul> |
|---|---|

Are you an ex-service man?

Name and Occupation.....  
(Please Write Plainly)  
Complete Address.....

## Agents: 90c an Hour



Introduce "Siderex." A new wonder. A pure solder in paste form. Works like magic. Sells all kinds. For mending water buckets, cooking stoves, milk pans, water tanks, tin roofs—everything including granite ware, gates, wire, tin, iron, copper, zinc, etc.

### Quick Sales—Nice Profit

Everybody buys. Housewives, mechanics, electricians, jewelers, plumbers, tourists, automobilists, etc. No leak too bad to recall. Just apply a little "Siderex." High a match and link. "Siderex" high a match and link with you. Write for sample and special proposition to agents.

American Products Co., 6574 America Bldg., Cincinnati, Ohio

## A Simple Radio- phone Receiver

By JAMES LEO McLAUGHLIN  
(Continued from page 1141)

number each fastener from right to left, 1 to 9. Alongside of hole No. 1 push two fasteners with a paper clip underneath—mark GND (ground). One half inch down from GND, punch a small hole; this is the starting point of the coil.

Take the wire and push the end thru the hole. Wrap the end around one of the fasteners GND (on the inside of the container). Be sure that where the wire touches the fastener, the enamel has been scraped off or else a poor connection will result.

Next pull the wire tight and commence winding the coil. The total number of turns is seventy, and a tap is taken off at each of the following turns: The 15th, 20th, 25th, 30th, 35th, 40th, 45th, 55th and the 70th.

Fig. 1 shows how to tap the coil. The important things to look out for are that the coil is wound as tight as possible, and that the enamel is scraped off the wire, where it makes connection with the fasteners. The 15th turn is contact No. 1, the 20th No. 2, etc.

The next job is the switch that moves over the contacts. Fig. 2 shows how this is made. Take one of the large fasteners, push the ends thru the side of the cover, close to the lid. Bend one end down flush with the side and push the other end thru the top and bend over.

Put the cover back on the container and bend the end of the fastener so that it rides over the contacts easily, when the cover is turned, but be sure that it touches each of them. Break off the surplus end.

The other large fastener is pushed thru the lid opposite the switch and is bent, as shown in Fig. 2, so that it can hold the small crystal. A short piece of bare wire (about No. 24 will do), acts as the cat-whisker, a pin is fastened to one end and the other end is wrapped around the end of the switch—the part that is bent over (see Fig. 2).

Fig. 3 shows the diagram of connections and needs little comment.

The telephone receiver is a single Murdock without head band, and can be purchased for about \$2.00. Of course any other kind may be substituted.

For the antenna one-half pound of No. 18 bare copper wire will do. This will give about 100 feet of wire. Two porcelain deats will also be required and should not cost over 5 cents. The wire can be had for about 30 cents.

String the wire the greatest length possible, and attach outer end to a tree or other elevation, at least thirty feet high (see Fig. 4). The other end of the wire enters the house and is attached to the switch button marked ANT and a short piece of rubber tubing should be slipped over the wire where it passes through the wall of the building.

A good ground can be had by connecting a wire to the nearest gas or water pipe. Scrape the pipe for a length of about two inches, so that it shines, then wrap several turns of wire around it and twist tightly.

To operate the set, bend the cat-whisker wire so that the pin rests on the crystal. Move the pin over the surface until a signal is heard; at the same time move the switch over the contacts, and leave it on the one that brings in the station the loudest. With this set in New York City using only a single No. 24 wire, 25 feet long strung up in a room, WDY'S and WJZ'S concerts came in fine, and on several occasions, the phone could be held about six inches from the ear and still the music and voice could be distinguished.



**DO YOUR OWN WIRING!**  
AND SAVE 50%

400 PAGES  
ILLUSTRATED

Anyone can become an expert wireman and secure a license by following the simple rules given in "Standard Wiring"

The National Authority for 28 Years

All the necessary rules, tables and illustrations needed for every kind of inside and outside wiring and construction for both direct and alternating currents, in accordance with the Underwriters' rules. The most complete and accurate book on wiring published. Twenty-eighth Edition just out.

Leather Cover. Gilt Edges. Pocket Size. \$9.00  
Sent on receipt of Price

H. C. CUSHING, Jr.  
8 WEST 40th STREET, NEW YORK

GENUINE GERMAN MAUSER  
Latest Model 9 Shot Automatic

25 CAL. \$12.95  
Less than half pre-war price.  
22 Cal. \$13.95. Shoots COLT'S and all standard cartridges. Convenient to carry—lies flat in the pocket—perfect safety device. All our guns brand new direct from factory, absolutely perfect.



8.45 25 CAL. BLUE STEEL ARMY AUTOMATIC — 31 Cal. \$19.45. DUB OTHER BIG SPECIALS: Vest Pocket Pistol. \$4.95. World's Famous Luger 30 cal. \$19.95. Hand Ejector Revolver swing out cylinder 32 cal. blue steel or nickel \$14.95. Pearl Handle \$15.95.

SEND NO MONEY

Pay Postman on Delivery.  
UNIVERSAL SALES CO.  
141 Broadway Dept. 140 New York, N.Y.



# SEX

Facts other sex books don't dare discuss are plainly told in "Where Knowledge Means Happiness." Creates a new kind of married love. One reader says: "It contains more real information than all other sex books put together."

From "Where Knowledge Means Happiness." Copyright 1921  
Sent in plain cover, by return mail, for \$1.00, cash-money order, check or stamps.  
COUNSEL SERVICE, Dept. 39, 257 W. 71st St., New York

## LEARN WATCH REPAIRING



You can learn by our modern and original system of instruction very part of the Watch Repairing Trade at home as good or better than at a shop. You can save money while learning and secure a well paying position or start in business after completing our course of instruction. Good watch repairs are always in demand and can be made from \$20 to \$25 per week. For particulars apply to the

MILWAUKEE SCHOOL OF WATCH REPAIRING, 168 Mason St., MILWAUKEE, WIS.



# A Simple Radiophone Receiver

By JAMES LEO McLAUGHLIN

Winner of First Prize \$100.00

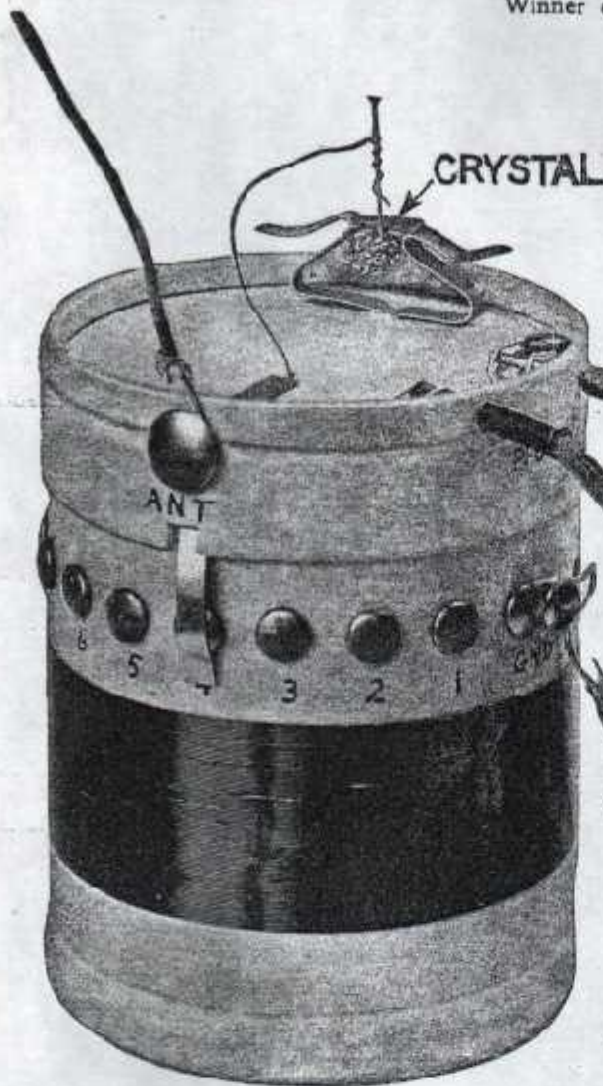

CRYSTAL

With Aerial Wire and Insulators Included, This Complete Radiophone Receiving Set Did Not Cost Over \$3.00 and This Covered the Cost of the Telephone Receiver.



**T**HE important points of this set are 1st: It is simple in construction and operation. A knife or razor blade and a small nail are the only tools required to make it. The complete set can easily be constructed in about one-half hour.

2d. It is inexpensive, the total cost, including the 'phone and antenna is less than \$3.00, the set itself costing only 21½ cents.

3d. It is as efficient as most of the crystal sets now being sold and in most cases superior to them.

## WHAT THIS OUTFIT WILL DO

**A**n outfit of this kind will bring in radiophone music and radiophone entertainment as sent out by the broadcasting stations providing the outfit is no more than 15 to 20 miles from the station.

The aerial in that case should be at least 60 feet long and composed of four wires.

An outfit of this kind cannot be used for any greater distance than 15 to 20 miles at the most. The further you are away from the broadcasting station the higher and longer your aerial must be.

—EDITOR.

The material required is as follows:

- 1 Paper container (4" in diameter).
- 13 Paper fasteners (small size).
- 2 Paper fasteners (large size).
- 3 Paper clips
- 2 Oz. No. 26 enameled copper wire.
- 1 Small piece of silicon or galena.
- 1 Common pin.

Take the container and pinch nine holes one inch down from the top, with a small nail, one half inch apart. Into each hole push a paper fastener. With pen and ink

(Continued on page 1172)

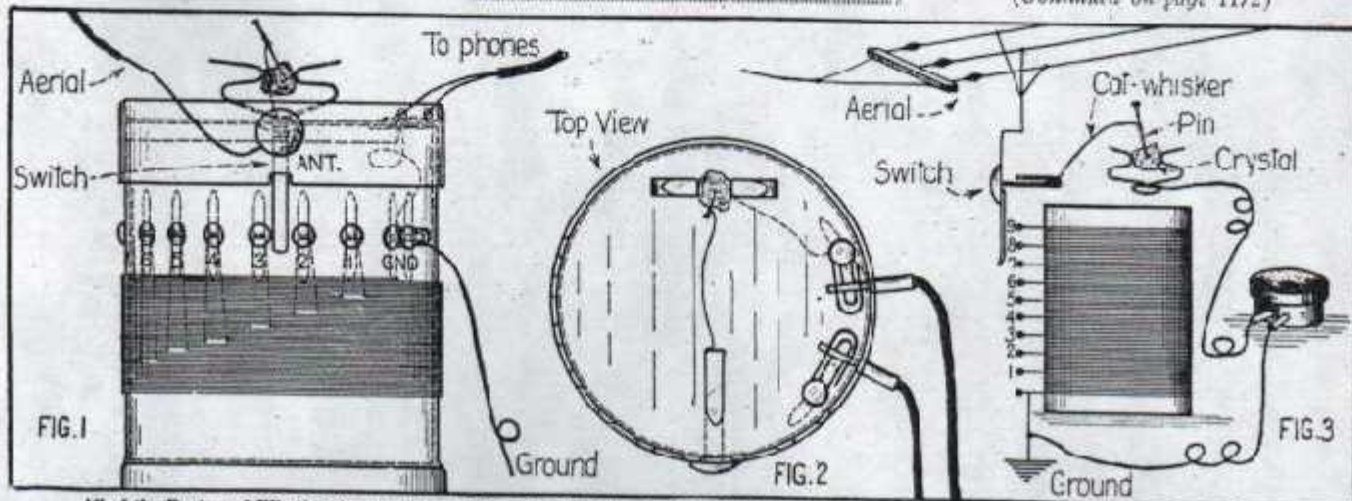

All of the Parts and Winding Arrangement Followed in Building the \$100.00 Prize-Winning Radiophone Receiving Set Are Here Illustrated.



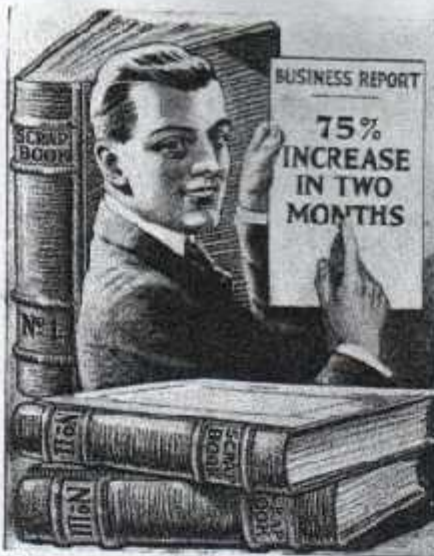

A New Jersey student writes:  
 "I have purchased a business and by the use of methods explained in my course have increased the business 75 per cent. in two months." This is just one extract from.

**Three Big Scrap-Books**

filled with appreciative, interesting letters from young men throughout the United States—all received recently. They show a national recognition of the unique features of the

**United Y. M. C. A. Courses and Correspondence-Teaching Methods**

The limited space permits only a few additional extracts.  
 "You bring out a man's resourcefulness."—California student.  
 "I like your personal service."—Missouri student.  
 "You take an interest in each student individually."—Connecticut student.  
 "You remind me of a great teacher—always ready to lend a helping hand."—Another Connecticut student.  
 "Too much cannot be said for Y. M. C. A. instruction service."—Illinois student.  
 "Course instructs through training. Am able to use the instruction in my regular work."—Ohio student.  
 "You seem to read every single word of my answers and even catch my pen-errors."—Massachusetts student.  
 "Course did me more good than the course I took in college."—N. Carolina student.  
 "If a man knows so much about all your system will bring it out."—Texas student.  
 "My course has not only brought more interesting work, but multiplied my earning power by three."—Nebraska student.  
 "Have been doing practical advertising lately and received favorable comments as to my manner."—N. Dakota student.

**Send for the "Six Reasons"**

why these ambitious young men and thousands of others have selected the United Y. M. C. A. Schools to guide them in their preparation for greater personal development, more responsibility, more congenial work or better paying work. Our friendly counsel is free.

**UNITED Y. M. C. A. SCHOOLS**  
 Dept. 64-A, 325 Lexington Ave.,  
 New York City

I am interested in United Y. M. C. A. Schools' service. Please give me free counsel as to the position or home-study course I have marked.

Accountant	Foremanship
Advertising Man	Highway Engineering
Agricultural Courses	Locomotive Operator
Aviation	Machine-Shop Practice
Auto Mechanic	Mathematical Courses
Banking	Mechanical Engineer
Barber Lessons	Plumber
Bookkeeper	Poultry Husbandry
Building Construction	Rails Operator
Business English	Rails Engineer
Business Law	Railroad Engineering
Business Organization	Salesman
Civil Engineer	Shorthand and
Civil Service	Typewriting
Concrete Engineer	Steam Engineer
Dairy Farming	Structural Drafting
Draftsman	Surveyor
Electrician	Tailor Dressing
Electrical Engineer	Traffic Management
English Courses	Use of the Slide Rule
Factory Management	
Farm Management	
Farm Motor Mechanic	

Are you an ex-service man?

Name and Occupation.....  
 (Please Write Plainly)  
 Complete Address.....

**Agents: 90c an Hour**

Introduce "Soderus." A new wonder. A pure solder in paste form. Works like magic. Solder all kinds. For mending water buckets, cooking stoves, milk pans, water tanks, tin roofs—everything including granite ware, gates, wire, tin, iron, copper, zinc, etc.

**Quick Sales—Nice Profit**

Everybody buys. Housewives, plumbers, electricians, jewelers, mechanics, tourists, automobileists, etc. No leak too bad to recall. Just apply a little "Soderus." Light a match and solder with you. Write for sample and special proposition to agents.

American Products Co., 6574 America Bldg., Cincinnati, Ohio

**A Simple Radio-  
 phone Receiver**

By JAMES LEO McLAUGHLIN  
 (Continued from page 1141)

number each fastener from right to left, 1 to 9. Alongside of hole No. 1 push two fasteners with a paper clip underneath—mark GND (ground). One half inch down from GND, punch a small hole; this is the starting point of the coil.

Take the wire and push the end thru the hole. Wrap the end around one of the fasteners GND (on the inside of the container). Be sure that where the wire touches the fastener, the enamel has been scraped off or else a poor connection will result.

Next pull the wire tight and commence winding the coil. The total number of turns is seventy, and a tap is taken off at each of the following turns: The 15th, 20th, 25th, 30th, 35th, 40th, 45th, 55th and the 70th.

Fig. 1 shows how to tap the coil. The important things to look out for are that the coil is wound as tight as possible, and that the enamel is scraped off the wire, where it makes connection with the fasteners. The 15th turn is contact No. 1, the 20th No. 2, etc.

The next job is the switch that moves over the contacts. Fig. 2 shows how this is made. Take one of the large fasteners, push the ends thru the side of the cover, close to the lid. Bend one end down flush with the side and push the other end thru the top and bend over.

Put the cover back on the container and bend the end of the fastener so that it rides over the contacts easily, when the cover is turned, but be sure that it touches each of them. Break off the surplus end.

The other large fastener is pushed thru the lid opposite the switch and is bent, as shown in Fig. 2, so that it can hold the small crystal. A short piece of bare wire (about No. 24 will do), acts as the cat-whisker, a pin is fastened to one end and the other end is wrapped around the end of the switch—the part that is bent over (see Fig. 2).

Fig. 3 shows the diagram of connections and needs little comment.

The telephone receiver is a single Murdock without head band, and can be purchased for about \$2.00. Of course any other kind may be substituted.

For the antenna one-half pound of No. 18 bare copper wire will do. This will give about 100 feet of wire. Two porcelain cleats will also be required and should not cost over 5 cents. The wire can be had for about 30 cents.

String the wire the greatest length possible, and attach outer end to a tree or other elevation, at least thirty feet high (see Fig. 4). The other end of the wire enters the house and is attached to the switch button marked ANT and a short piece of rubber tubing should be slipped over the wire where it passes through the wall of the building.

A good ground can be had by connecting a wire to the nearest gas or water pipe. Scrape the pipe for a length of about two inches, so that it shines, then wrap several turns of wire around it and twist tightly.

To operate the set, bend the cat-whisker wire so that the pin rests on the crystal. Move the pin over the surface until a signal is heard; at the same time move the switch over the contacts, and leave it on the one that brings in the station the loudest. With this set in New York City using only a single No. 24 wire, 25 feet long strung up in a room, WDY'S and WJZ'S concerts came in fine, and on several occasions, the phone could be held about six inches from the ear and still the music and voice could be distinguished.



**DO YOUR OWN WIRING!  
 AND SAVE 50%**

400 PAGES  
 ILLUSTRATED

Anyone can become an expert wireman and secure a license by following the simple rules given in "Standard Wiring"

The National Authority for 28 Years

All the necessary rules, tables and illustrations needed for every kind of inside and outside wiring and construction for both direct and alternating currents, in accordance with the Underwriters' rules. The most complete and accurate book on wiring published. Twenty-eighth Edition just out.

Leather Cover. Gilt Edges. Pocket Size. \$9.00  
 Sent on receipt of Price

H. C. CUSHING, Jr.  
 8 WEST 40th STREET, NEW YORK

**GENUINE GERMAN MAUSER**  
 Latest Model 9 Shot Automatic

25 CAL. Less than half pre-war price.

**\$12.95**

22 Cal. \$13.95. Shoots COLT'S and all standard cartridges. Convenient to carry—lies flat in the pocket—perfect safety device. All our guns brand new direct from factory, absolutely perfect.

**8.45** 25 Cal. BLUE STEEL ARMY AUTOMATIC — 31 Cal. \$19.45. OUR OTHER BIG SPECIALS: Vest Pocket Pistol. \$4.95. World's Famous Luger 30 cal. \$19.95. Hand Ejector Revolver swing out cylinder 32 cal. blue steel or nickel \$14.95. Pearl Handle \$15.95.

**SEND NO MONEY**

Pay Postman on Delivery.  
**UNIVERSAL SALES CO.**  
 141 Broadway Dept. 140 New York, N.Y.

**GOES DIRECT TO THE HEART OF THE SEX QUESTION**

**SEX**

Facts other sex books don't dare discuss are plainly told in "Where Knowledge Means Happiness." Creates a new kind of married love. One reader says: "It contains more real information than all other sex books put together."

From "Where Knowledge Means Happiness." Copyright 1921

Send in plain cover, by return mail, for \$1.00, cash-money order, check or stamps.

**COUNSEL SERVICE, Dept. 39, 257 W. 71st St., New York**

**LEARN WATCH REPAIRING**

You can learn by our modern and original system of instruction very part of the Watch Repairing Trade at home as good or better than at a shop. You can save money while learning and secure a well paying position or start in business after completing our course of instruction. Good watch repairs are always demanded and earn from \$20 to \$25 per week. For particulars apply to the

**MILWAUKEE SCHOOL OF WATCH REPAIRING, 168 Mason St., MILWAUKEE, WIS.**



# A Simple Radiophone Receiver

By JAMES LEO McLAUGHLIN

Winner of First Prize \$100.00

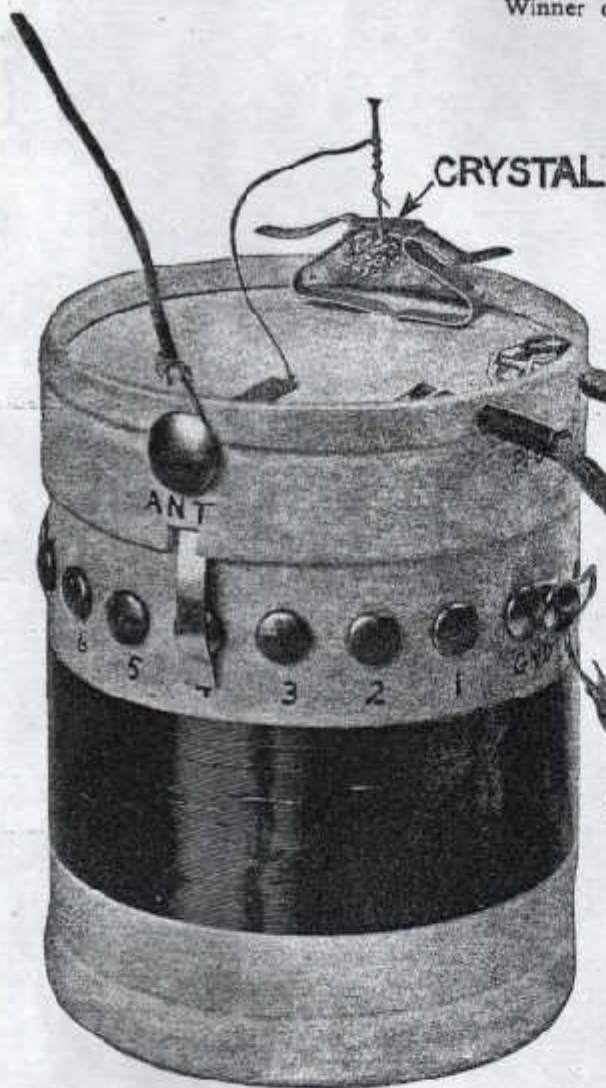

CRYSTAL

With Aerial Wire and Insulators Included, This Complete Radiophone Receiving Set Did Not Cost Over \$3.00 and This Covered the Cost of the Telephone Receiver.



**T**HE important points of this set are 1st: It is simple in construction and operation. A knife or razor blade and a small nail are the only tools required to make it. The complete set can easily be constructed in about one-half hour.

2d. It is inexpensive, the total cost, including the 'phone and antenna is less than \$3.00, the set itself costing only 21½ cents.

3d. It is as efficient as most of the crystal sets now being sold and in most cases superior to them.

## WHAT THIS OUTFIT WILL DO

**A**n outfit of this kind will bring in radiophone music and radiophone entertainment as sent out by the broadcasting stations providing the outfit is no more than 15 to 20 miles from the station.

The aerial in that case should be at least 60 feet long and composed of four wires.

An outfit of this kind cannot be used for any greater distance than 15 to 20 miles at the most. The further you are away from the broadcasting station the higher and longer your aerial must be.

—EDITOR.

- The material required is as follows:
- 1 Paper container (4" in diameter).
  - 13 Paper fasteners (small size).
  - 2 Paper fasteners (large size).
  - 3 Paper clips
  - 2 Oz. No. 26 enameled copper wire.
  - 1 Small piece of silicon or galena.
  - 1 Common pin.

Take the container and pinch nine holes one inch down from the top, with a small nail, one half inch apart. Into each hole push a paper fastener. With pen and ink

(Continued on page 1172)

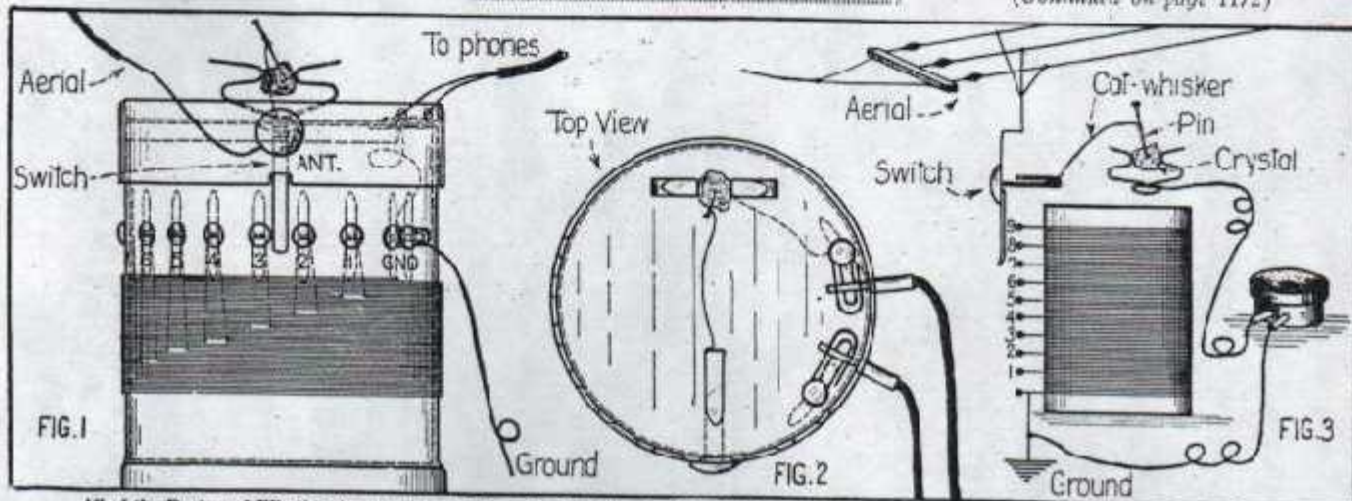

All of the Parts and Winding Arrangement Followed in Building the \$100.00 Prize-Winning Radiophone Receiving Set Are Here Illustrated.



# Selective, Fixed Detector CRYSTAL SET

Try this new-type crystal set. It really separates the stations, even in the big city

By N. J. RUBENS

Engineering Division, Allied Radio Corporation

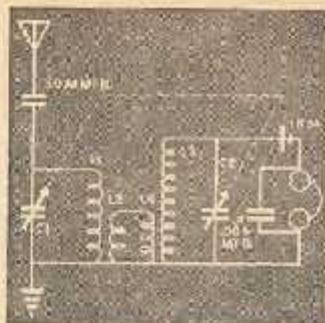

#### LIST OF MATERIALS

- 1 1N34 diode detector
- 1 2 gang 450 mmfd. variable condenser
- 2 Coils (Allied Radio #80-950)
- 1 50 mmfd. mica condenser
- 4 Fahnestock clips
- 4 L Buckle's
- 8 Wood screws
- 6 6/32-1/4" B.H. machine screws
- 1 Tuning knob
- 7 No. 6 soldering lugs
- 1 .004 mfd. mica condenser



tions with better than average selectivity. This is accomplished by the use of two tuned circuits instead of the usual single tuned circuit used in most crystal sets. Like all crystal sets, this receiver requires no external power to operate it. It is simple to construct and operate, and is economical to build.

Of the two important special features of this set, one is the use of a 1N34 crystal diode. It provides for greater sensitivity, eliminates the need for adjustment, requires no special mount, and may be wired into the circuit directly. The crystal is protected from dust and dirt and is less subject to damage in use. Its small size makes it convenient to use. The same crystal, as in this set, was developed during the war for use in radar equipment as

ONE of the greatest shortcomings of the average crystal set in providing satisfactory broadcast reception, especially in metropolitan areas, is lack of sufficient selectivity to separate stations. The receiver described in this article is an offshoot of the old-fashioned crystal set that has been popular for so many years. But it has now been brought up to date, especially with regard to selectivity.

This set is designed to cover the broadcast band and to produce good volume on local sta-

tion. It is now available for general use and, while it is more expensive than the old crystal detector, it is worth the difference.

The variable selectivity incorporated in this crystal set is found in few other crystal sets. It is especially advantageous when the receiver is to be used in an area serviced by two or more local broadcast stations. With the set adjusted for maximum selectivity, the simultaneous reception of two or more local stations which is characteristic of the average crystal set, is greatly



minimized and in most instances it has been entirely eliminated.

Variable condenser tuning is used in preference to tapped coils or otherwise-variable inductances for greater ease of operation and compactness of construction.

In assembling the parts for this set, it is important to first determine the correct position of the variable condenser in relation to the base board. The condenser must be mounted so that when the plates are unmeshed the rotor plates do not hit the base board. The four holes on the bottom of the condenser, two front and two rear nearest the corners, are then tapped to take  $\frac{1}{4}$ - $\frac{1}{2}$  inch machine screws to mount the condenser brackets. Self-tapping metal screws may be used instead of tapping the condenser frame but in either instance care must be taken to prevent the ends of the screws from interfering with the movement of the rotor plates or from shorting rotor to stator, depending on the make of variable condenser used. Mount the coils in the manner described above, on the condenser frame using the two holes nearest the top rear corners. Screw faststock clips and soldering lugs to the base board of the set.

Before proceeding with the wiring, it is important to note that the end of the coil nearest the bracket is called the "cold" end, and is the bottom of the coils in the schematic diagram. Failure to note this point will result in reduced selectivity, you will find.

After the condenser mounting brackets and coils have been attached to the condenser, the coils should be wired into the circuit with the exception of the variable condenser ground connection and the connection to the series antenna condenser; however, the length of these leads should be approximated and soldered to the variable condenser. The IN34 is now attached to the variable condenser. Attach the variable condenser and coil assembly to the base board and complete remainder of the wiring.

No special adjustments are required to place the set in operation. Connect antenna, ground, and phones to the proper clips. Selectivity is varied by moving the coupling coils (L-2 and L-4), selectivity increasing as the coils are moved down the tuned coils. It will also be found that as the coupling coils are moved up to decrease selectivity, volume is increased. In areas having few broadcast stations well separated in frequency, it will be found desirable to adjust for minimum selectivity and maximum volume although volume will still be satisfactory when the set is adjusted for maximum selectivity. Care should be exercised in adjusting coupling coils to prevent breaking the coil leads.

Tune slowly and carefully for maximum volume and re-adjust coupling coils for optimum volume and selectivity when necessary. Also necessary for proper operation are a good antenna and ground. An out-door antenna as high and long as conveniently possible should be used.

It is advisable to use high impedance headphones. Although low impedance phones will work they will usually decrease selectivity. Double headphones with a resistance of about 2,000 ohms are preferred. A set of headphones is the only accessory needed to operate the crystal set.

When circuit L1-C1 is tuned to the frequency of a station, current flows in the circuit and sets up a magnetic field which cuts the turns of coils L2, causing a current to flow in circuit L2-L4. By inductive coupling, energy is transferred from L4 to the tuned circuit L3-C2 which is identical to and ganged with L1-C1. The radio frequency current is rectified by the 1N34 and its audio frequency component reproduced by the headphones. Greater selectivity is obtained by using two loosely-coupled tuned circuits. Capacitive coupling between antenna and detector circuit is minimized by grounding the "cold" end of each inductance.

## Insulating Wires

ON ELECTRICAL work, the home craftsman is normally at a great disadvantage when it becomes necessary to insert wires in Irvolite and other types of flexible insulation tubing—especially when tight fits and neat appearance are essential. Accompanying drawings indicate a tool and a method with which this disadvantage may be overcome.

The tool is a vise-like gadget whose jaws are arranged to open and close the two halves of a tapered nozzle. Up and down adjustments of the jaws and nozzle are accomplished manually with a handle and screw mechanism.

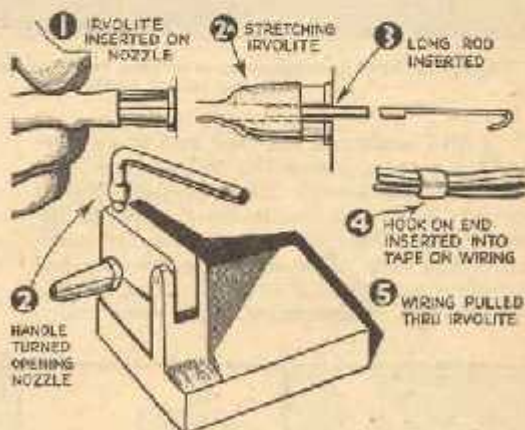

When the nozzle halves are in contact with one another, the flexible insulating tube can be easily slipped over their outer surfaces. Then, when the nozzle halves are separated, the mouth of the tube is stretched open.

The wires that are to be insulated should then be taped together so that they can be pulled into the required position with a rod-hook through the stretched tube end.—T. A. DICKINSON.



# Build the SEE-THROUGH CRYSTAL RADIO RECEIVER

by Art Trauffer

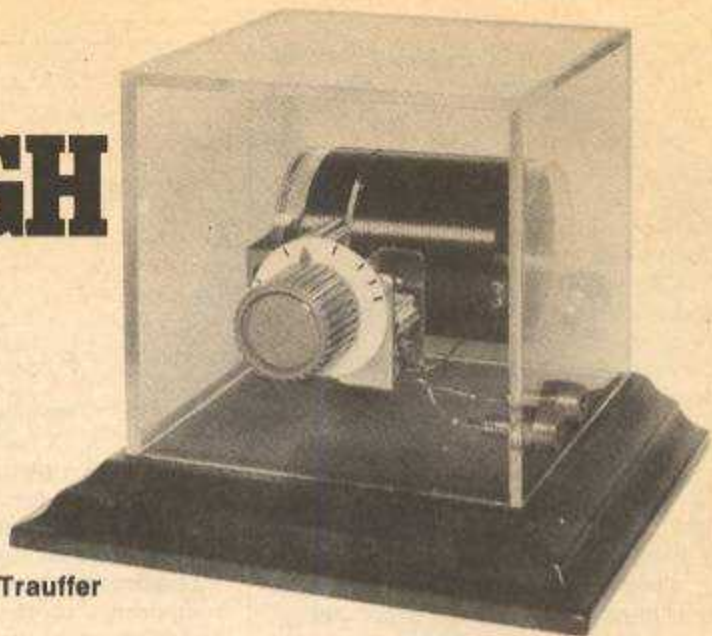

□ Have you ever wanted to recreate those old days of listening to AM radio on a crystal set and headphones? No tubes, no batteries, no hum, no nothing but pure clean sound drifting out of the ether into your headset? If you have the yen to get a crystal set which has the advantage of using a crystal diode instead of the old unreliable cats-whisker and galena crystal, this radio is the one for you to build. In addition to being about as good a power-supplyless AM receiver as you can make, it's also a pleasure to look at.

It closely resembles the beautiful glass-enclosed radio receivers that were custom-built by manufacturers for display in radio exhibitions in the 1920's. Manufacturers of radio receiver kits mounted and wired their kits in glass cabinets so the visitors could see the "works" from all angles instead of lifting the lid to look inside. Those glass cabinet radios are now rare collectors

items.

This crystal radio also saves you the work and expense of making a wood cabinet, and it is low-loss for radio frequencies because the cabinet and coil form are made of styrene plastic which is a good dielectric material. The cabinet is simply a clear plastic 4-in. square photo display cube, and the coil form is a clear plastic pill container about 2-in. in diameter.

**Circuit Description.** The simple schematic diagram shows a time-tested hookup which is still widely used, but it's improved here by connecting one side of the crystal diode to a tap on the secondary, L2. This greatly increases the receiver's selectivity and helps you separate the powerful local stations.

**Making the Coil.** To make coils L1 and L2 the four ends of the coils are anchored in small holes drilled through the wall of the plastic container and spotted with Duco cement. You can also

make small holes by pushing a hot sewing needle through the plastic. To make the tap on the coil, simply twist a small loop in the coil and spot it with Duco cement. Scrape the enamel insulation off the loop, and solder to it.

**Build Your Own or Ours.** The plastic cube makes a very attractive enclosure, as you can see in the photographs. However, the parts layout isn't at all critical, and you can breadboard this radio any way you want, so long as it's wired correctly. If you want to have a beautiful-looking radio you can show off you'll follow the model I made which is shown in the photographs.

**Mounting The Parts.** The photograph shows how the parts mount inside the plastic box. The coil form is mounted to the rear of variable capacitor C1 by means of a brass angle-bracket. Use lockwashers wherever needed to hold the screws, binding posts, and phone tip jacks securely to the plastic material.

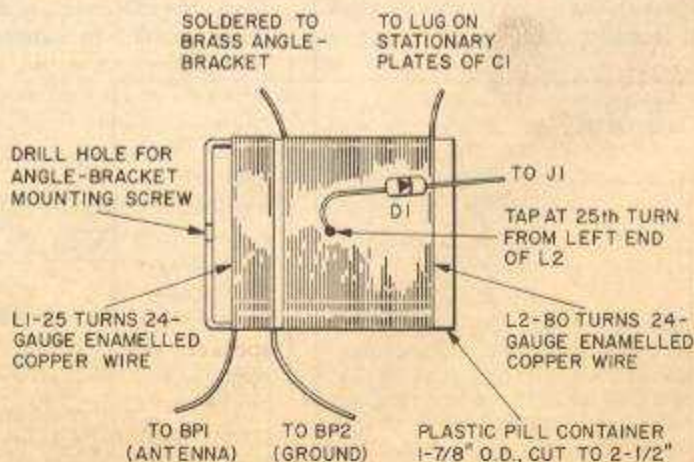
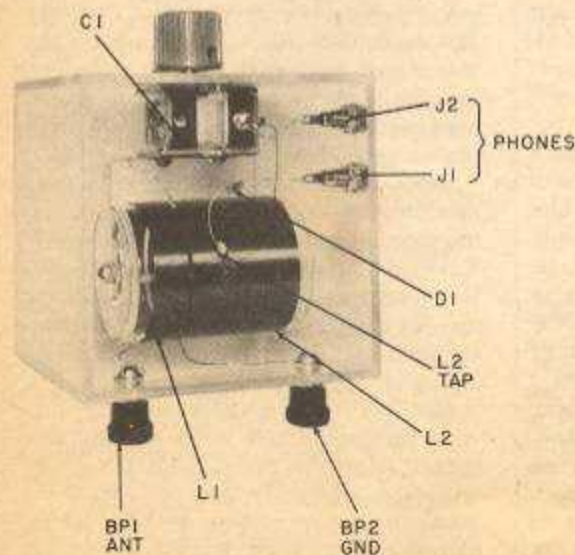

Apart from getting hold of the parts, construction of the See-Through Crystal Set should take you less than two hours in all. You can use any kind of box you want, but the lucite box shown will make it into a real showpiece.



When assembling and wiring this receiver be careful not to scratch the plastic, and keep the soldering iron well away from the plastic. If you use rosin core solder, protect the plastic by covering it with pieces of paper taped in place to keep the rosin from splattering on the plastic.

The completed crystal radio is mounted on a fancy walnut base purchased from a woodworking shop. The plastic box is secured to the wood base by spotting the four corners of the bottom of the box with Duco cement. The dial for the pointer knob is simply a small disc of white double-weight paper held to the plastic box with a spot of Duco cement. Make pencil marks at the places where your local stations come in.

Use of a pair of sensitive high-impedance magnetic or crystal earphones, a good connection to a cold water pipe, and a long outdoor antenna (for best results, put up a long single-wire, random-length antenna.) With a simple crystal set it becomes particularly important that the antenna-ground system be the best possible. Remember, unlike its bigger cousin, the superheterodyne, the crystal set does not have rf amplifiers and other circuitry to help it pull in all those signals floating around out there in the ether. ■

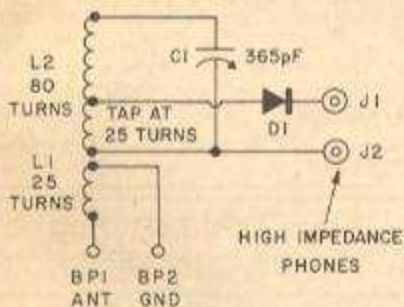

#### PARTS LIST FOR CRYSTAL RADIO

- BP1, 2**—Binding posts for antenna and ground connections, may be any convenient type
- C1**—365-pF variable tuning capacitor, single-gang.
- D1**—Small-signal, general purpose diode, similar to 1N34.
- J1, 2**—Jacks for headphones (dependent on phone(s) selected).
- Misc.**—Headphone(s), high impedance. May be crystal or magnetic, or small earphone as supplied with transistor radios and portable tape machines; plastic photo display cube, approx. 4-in. each dimension; plastic pill container, 1 7/8-in. diameter, for use as coil form; 1/4-lb. 24-gauge enamelled copper magnet wire (Radio Shack 278-004 or equiv.); brass mounting strip, assorted screws, nuts and lockwashers.



# Receptor miniatura a galena

Por M. D.

Habíamos conservado, a título de curiosidad retrospectiva, un receptor a galena que databa de casi veinte años atrás. Sus dimensiones, especialmente la de su bobina, son impresionantes. Comparándolo con el receptor que describimos se constata que, si bien los esquemas de los aparatos a galena han evolucionado poco, las construcciones actuales se han visto beneficiadas por los progresos hechos en la construcción de los elementos constitutivos. Estos progresos han permitido reducir el tamaño y obtener, así, receptores menos voluminosos, más estéticos y de manipulación cómoda.

Sin embargo, gracias a una adaptación juiciosa de los elementos, hay que reconocer que el receptor que se describe bate todos los records desde el punto de vista de la pequeñez, sin que esto, entendiéndose bien, afecte en absoluto sus cualidades radi-eléctricas, que son las mismas que para los mejores aparatos a galena, gracias a la calidad del cristal y el condensador variable empleados.

El interés de este aparato miniatura es, por lo tanto, real para cualquier aficionado que desee un verdadero receptor de bolsillo, ya que, además de sus cualidades propias referentes a su construcción, tiene todas las ventajas de los aparatos a galena: buena reproducción, funcionamiento sin fallas y precio económico.

El aparato es muy simple: y tén-

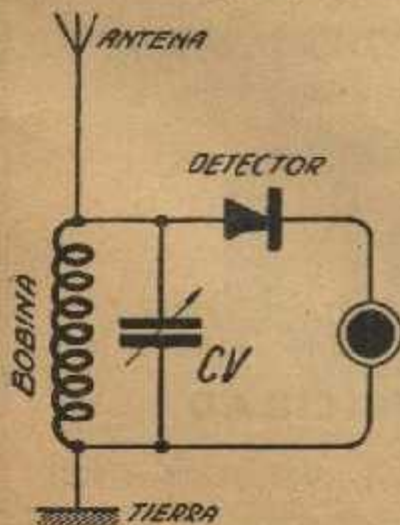

Fig. 1

gase en cuenta que en un receptor a galena, simplicidad es sinónimo de sensibilidad. Examinando el esquema vemos que se trata de un circuito sintonizado «directo», ya que la bobina controlada por el condensador variable se encuentra directamente colocada entre antena y

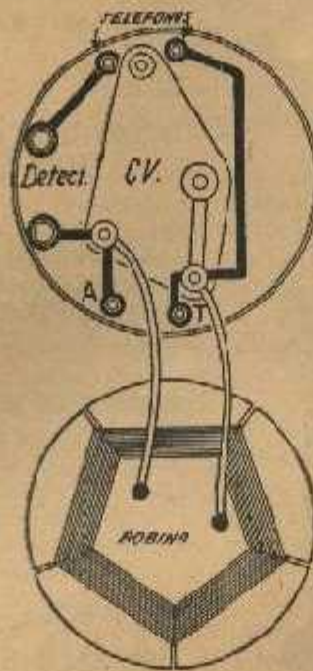

Fig. 2

tierra. El circuito oscilante así constituido presenta máxima impedancia para la frecuencia captada por la antena sobre la cual se encuentra sintonizado y se recoge en los extremos del condensador variable una tensión de alta frecuencia lo suficientemente elevada como para impresionar los teléfonos luego de haber sido detectada por la galena.

## Descripción de los elementos

Los elementos requeridos para la construcción del aparato son los siguientes:

1° Una bobina tipo «fondo de canasta» lo más plana posible, bobinada sobre una hoja de cartón en la cual se practican 5 hendiduras y que tenga exactamente las dimensiones de la caja. Se la recubre con otra hoja de cartón a fin de aislar el bobinado de las demás piezas. Esta bobina es confeccionada para la recepción de la gama de onda de broadcasting con alambre de 3/10,

aislado por dos capas de algodón y comprende en total 36 vueltas, es decir, 18 de cada lado del cartón de soporte.

2° Un condensador variable, con dieléctrico de mica o pertinax, de una capacidad de 0,0005 mfd. (500 mmfd.). Su tamaño es extremadamente reducido.

3° Un cristal con «bigote», este último con brazo articulado y que permita efectuar contactos lo más estables posibles.

4° Teléfonos lo más sensibles posibles.

El armado de este aparato se encuentra al alcance de un escolar de diez años. Los elementos se disponen en una pequeña caja redonda, de bakelita, dividida en dos partes, que ajusten una con la otra. La bobina se dispone en el fondo de la caja y bajo la cubierta se fija el condensador variable, con su perilla de sintonía encima. Como puede verse en la figura que muestra el aparato por arriba, esta perilla no se encuentra en el centro de la caja, sino ligeramente desviada hacia un costado, para dejar espacio libre destinado al montaje del cristal y su «bigote».

Por otra parte, se sujetan a la tapa los bornes correspondientes a antena y tierra, como también los des-

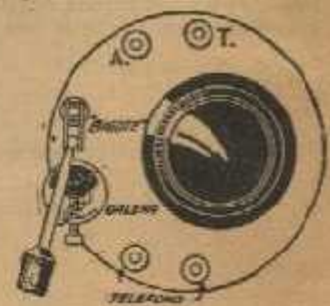

Fig. 3

tinados a la conexión de los teléfonos. En otras palabras, además del agujero correspondiente al eje del condensador variable, la tapa será provista de seis perforaciones cuyo espaciado se encuentra indicado en el esquema de conexiones. En dos de estos agujeros se fijan la galena y el buscador respectivamente y en los cuatro restantes, cuatro tornillos roscados con tuercu y bornes.

(Continúa en la pág. 35)



## ¿Correcto o incorrecto?

1. En un audíocamplificador con acoplamiento a resistencias, cuanto más elevada sea la resistencia de carga de placa, más plana será la respuesta de frecuencia o característica, ya que en ese caso la resistencia fija constituye una mayor parte de la resistencia total y el efecto reactivo de la carga de la válvula queda eliminado.

2. El tubo de rayos catódicos 913 puede trabajar con el mismo devanado de calefactor que el amplificador y las otras válvulas del osciloscopio, debido a que dicho tipo (el 913) está construido en forma tal que cuenta con una gran diferencia de potencial (c. c.) entre cátodo y calefactor.

3. La diferencia de fase entre los circuitos de grilla y placa de una válvula termoiónica es 180 grados, y excepto que se generen muy elevadas radiofrecuencias el ángulo de fase se hace menor pudiendo tener los dos circuitos la misma fase, requiriendo para la oscilación que el devanado de reacción se encuentre conectado en el mismo sentido exactamente que la bobina de grilla cuyo devanado se encuentra acoplado al de placa.

4. Las señales de televisión dependen del ancho de banda presente en el receptor de modo que la amplia variación de amplitud, introducida por la modulación

pueda ser pasada sin mucha atenuación, asegurando así imágenes más claras y reales; por lo tanto, una ligera diferencia entre la f. i., generada en un receptor superheterodino y la frecuencia a la cual se halla sintonizado el canal de f. i., del receptor, mejora la aptitud para manejar modulación de mayor ancho.

5. La característica de respuesta de un amplificador de f. i., o r. f., puede obtenerse solamente mediante la verificación visual sobre un osciloscopio de rayos catódicos y, por lo tanto, el ajuste «achatao» de la parte superior de la curva sin un osciloscopio resulta imposible de lograr.

6. Las frecuencias que son múltiplos enteros de una frecuencia fundamental, son sus armónicas. La fundamental es la primera armónica. La intensidad de las armónicas disminuye a medida que aumenta el orden superior de las mismas, rápidamente al principio, en forma menos pronunciada después, hasta que la diferencia de intensidad entre armónicas de orden superior, consecutivas y otras más elevadas se torna despreciable.

7. Un óhmetro calibrado para una escala es aplicable a valores más alto de resistencia mediante un factor igual a aquel por el cual la tensión externa y resistencia limitadora son multiplicados.

### Respuesta

1. **INCORRECTO.** Debido a la capacidad de salida de la válvula y a la capacidad asociada del circuito en paralelo a la salida, la influencia de esta capacidad resulta aumentada cuanto mayor es la resistencia de carga de placa; la respuesta sobre las frecuencias altas resulta grandemente reducida a medida que se aumenta la resistencia de carga considerablemente por encima del valor normal. La resistencia relativa de la carga con respecto a la propia válvula no guarda relación directa sobre el asunto en el sentido indicado.

2. **INCORRECTO.** El devanado de calefactor es positivo con respecto al menos B por la caída en la resistencia de polarización, por lo general constituida por un potenciómetro en el circuito de drenaje, siendo alimentado el calefactor por medio de un arrollamiento independiente. El tubo 913 posee el calefactor unido al cátodo en el interior del tubo y, por lo tanto, se halla construido para no tener ninguna diferencia de potencial entre calefactor y cátodo.

3. **CORRECTO.** El desplazamiento de fase del circuito

de grilla bajo tales circunstancias ha sido descubierto sólo hace poco tiempo.

4. **CORRECTO.** El mayor ancho de banda del amplificador de frecuencia intermedia ligeramente fuera de sintonía se debe a la característica de respuesta mucho más ancha sobre un lado que sobre el otro, y por lo tanto si se favorece una sola banda lateral, la «acomodación» en esta banda lateral es mucho más ancha que la normal.

5. **INCORRECTO.** En la práctica puede hacerse uso de un generador de señales y de un voltímetro a válvula y obtener fácilmente la característica de respuesta.

6. **CORRECTO.** En la generalidad de los casos la fundamental recibe el nombre de primera armónica.

7. **CORRECTO.** La escala correspondiente al alcance bajo puede multiplicarse por 10 si las resistencias limitadoras son igualmente multiplicadas, o por 100, o cualquier otro factor aplicable a todos los tres.

(De «Radio World»)

### RECEPTOR MINIATURA

Las conexiones a llevar a cabo con cable aislado, son las dos salidas de la bobina que van a las láminas fijas del condensador una de ellas, y la otra a las móviles. Estas últimas están igualmente unidas por un cable aislado a uno de los bornes de los teléfonos y por un alambre, que puede ser desnudo, ya que es muy corto, al borne de tierra.

Por otra parte, las láminas fijas están unidas al borne del «bigote»

### A GALENA (Véase de la pág. 24)

y a la salida de la antena. Finalmente, el soporte del detector (cristal) se conecta al otro borne del teléfono.

Como con todos los aparatos a galena, a fin de obtener una buena audición de las estaciones, se requiere una antena exterior bien despejada y una buena toma de tierra. Con un buen colector de ondas, este aparato permite escuchar emisoras de potencia mediana que se encuentren dentro de un radio de 25

a 75 kilómetros, según las condiciones de propagación. Con una antena muy larga, de 50 metros más o menos, pueden esperarse resultados muy superiores.

Cuando se trata de recepción local, el sector (línea de canalización) puede ser empleado como antena. En tal caso, será necesario intercalar en la conexión de antena un condensador fijo de 0,0002 mfd. (200 mmfd.)

(De «Le Haut Parleur»)



hilo F, pudiendo así dar vuelta alrededor de un eje vertical. Sobre estas superficies caía la radiación electromagnética concentrada por una lente de parafina.

En virtud de un fenómeno indicado por Crooks, el color producido en la superficie de estas cintas metálicas, por la corriente inducida en la maza de metal a la llegada de la onda electromagnética, hacía dar vuelta a todo el aparato, suspendido por el hilo F. Suspendido en el vacío, pesaba menos de un miligramo y era sensible a la diez millonésima parte de un grado. Se podía leer el valor de la rotación, gracias al desplazamiento del espejo M, y el ángulo de rotación estaba en relación con la intensidad de corriente desarrollada en el receptor. Enviando sobre este dispositivo radiaciones infra-rojas, se pudo observar fenómenos del mismo orden, que los dados por la onda electro magnética y verificar la identidad de los fenómenos.

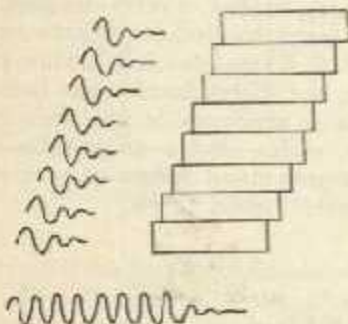

Fig. 18. — Representación esquemática del interferómetro que emplearon los señores Nicholls y Tear. Un tornillo micrométrico permite cambiar el desplazamiento de las distintas partes que constituyen el interferómetro. Las ondas que recorren distintos caminos, según el valor de ese desplazamiento, producen a la recepción refuerzos o debilitamientos, que permiten evaluar el largo de la onda transmitida.

Quedaba entonces por medir la onda transmitida que era una onda amortiguada. Se empleó para ello un interferómetro compuesto primero de dos espejos sobrepuestos y desplazados, el uno con relación al otro, de una cantidad que se podía hacer variar por medio de un tornillo micrométrico, o bien por medio de una serie de

se obraba lo mismo con un tornillo. La onda reflejada sobre este sistema, antes de llegar al receptor, se descomponía en una serie de ondas que recorrían caminos distintos (fig. 18), y cuya superposición daba lugar en el receptor a franjas de interferencias, a reforzamientos y a debilitamientos. Se podía tener una medida exacta del largo de la onda emitida, observando los reforzamientos y los debilitamientos y la diferencia del camino recorrido entre el receptor y el transmisor, diferencia dada por la posición del tornillo micrométrico del interferómetro. Nicholls y Tear han podido así hacer obrar sucesivamente sobre un dispositivo receptor, una onda electro-magnética que tenía un cuarto de milímetro de largo más o menos, y la radiación infra-roja más larga actualmente descubierta, cuyo largo de onda alcanzaba un valor superior, más o menos igual a un tercio de milímetro. Han constatado una analogía absoluta, entre los efectos de esta última radiación y los de la onda electro-magnética.

Se puede pues admitir, en la hora actual, que ninguna discontinuidad existe ya entre el dominio de radiaciones caloríficas y luminosas, prolongado el mismo por el de los rayos X y  $\gamma$ .

Ahora, entrando en la gama de las ondas cortas, industrialmente utilizables, si echamos una ojeada para concluir sobre los resultados ya adquiridos y sobre las investigaciones más directamente útiles que las que acabamos de indicar, podemos decir lo siguiente:

Bajo muchos puntos de vista, las ondas cortas han salido ya del dominio experimental y rinden, desde ahora, señalados servicios.

Bajo el punto de vista comercial se puede contar con ellas, para doblar las estaciones de ondas largas, mucho más regulares, y cuyo empleo si se quiere comunicar a toda hora del día y en toda época, parece ser necesario por largo tiempo todavía por oneroso que sea, comparando los gastos de

de gran potencia. Para comunicaciones lejanas y que no importa si atrasan un poco, las ondas cortas pueden ya considerarse como único medio de comunicación. Es el caso de ciertas transmisiones meteorológicas o transmisiones a las colonias de poca importancia comercial. También es este el caso, para las comunicaciones al interior mismo de ciertas colonias.

Bajo el punto de vista militar el empleo de estaciones de ondas cortas, aumenta la posibilidad de transmisiones simultáneas, siempre más numerosas y permitirá quizás utilizar la radiotelefonía en los ejércitos. Lo que queda por buscar, para que las transmisiones de ondas cortas puedan ser empleadas con más seguridad y más útilmente todavía, es primero conocer las leyes de su propagación, siempre que este fenómeno fuera sometido a leyes.

¿Si no se encuentran más que fenómenos de índole meteorológico, permitirá una observación bastante larga determinar las mejores ondas que deben emplearse en una época y para fines dados? Parece que se hacen actualmente algunos progresos en este sentido y la estación de ondas cortas del porvenir, será quizás una estación de varias ondas transmitidas simultáneamente o sucesivamente y que podrían cambiarse casi instantáneamente. Quizás también se utilizarán industrialmente ondas cada vez más cortas y se descubrirá algo de preciso sobre las propiedades terapéuticas de ellas. Igualmente es posible que la observación metódica y razonada de los fenómenos de propagación conduzca a grandes progresos para la previsión del tiempo. Grandes esperanzas son ciertamente permitidas, y grandes trabajos quedan por hacer. Pero se puede decir desde ahora, que el estudio de las ondas cortas, es un capítulo importante y nuevo en la historia de la técnica hertziana, o que el empleo de estas ondas, cuyas consecuencias son bastantes importantes ya, revolucionarán quizás un día, todas las nociones actualmente adquiridas.

## RECEPCIÓN CON GALENA, por CONSTANTINO GARCÍA

Me animó a escribir esto, el excelente artículo de John English sobre «Recepción de alta calidad», aparecido en el número 176 de REVISTA TELEGRÁFICA.

¿Por qué avergonzarse de un receptor a galena? Muchos poseedores de receptores de varias lámparas solo son capaces de recibir las estaciones locales, cosa que cualquier «galenero» hace, obteniendo mejor calidad.

La calidad única que proporciona una galena (en las locales) es recu-

erida por todo aficionado sin prejuicios siempre que tenga oído. Naturalmente, algunos solo acaban por reconocerlo después de haber ensayado toda la familia de los *dinos* en busca de «EL RECEPTOR»; no son pocos los que emplean galenas calladamente, sin duda por pudor de utilizar cosa tan modesta.

La reproducción que proporciona una lámpara en estaciones locales o con señales muy intensas nunca es exacta a menos de utilizar lámpara de alto rendimiento y alto consumo, en simple detectora con grilla polarizada (Batería «C») y sin regeneración; las lámparas de consumo reducido, tan



extensamente empleadas, no pueden, a menos de forzar el filamento, «mapear» una corriente de placa proporcional al potencial impreso en grilla; es decir, que si bien señales débiles «pasan», las señales más fuertes son disminuidas; resultado: distorsión.

Ahora bien no hay ventaja en utilizar una lámpara de alta emisión y poca impedancia (lámpara de «poder») para obtener el resultado que da una galena; me refiero a galena por ser el cristal más satisfactorio en sensibilidad.

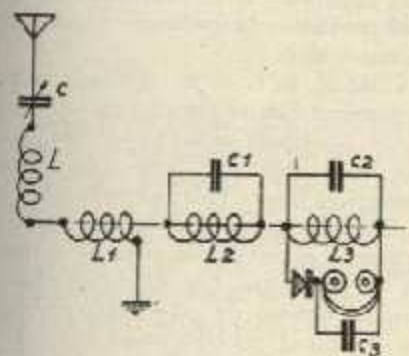

L2 - 14 vueltas, 11 cm. de diam. alambre de mampilla.  
 L3 - 30 vueltas, mismo alambre y diámetro.  
 L1 - 20 vueltas, 6 cm. de diam. alambres de 0.5 mm.  
 L - Según la longitud de antena.  
 C - Cond. variable 45 placas.  
 C1 y C2 - Cond. variable 13 placas.  
 C3 - Cond. fijo 0.002 mfd.

Prácticamente el único defecto de los receptores a galena, en cuanto a recepción local se refiere, es su falta de selectividad y para resultados satisfactorios es necesario emplear circuitos relativamente más complicados, aunque menos caros, que los utilizados con lámpara.

Pero muy pocos aficionados estarían dispuestos, al construir un receptor a galena, a emplear el cuidado, tiempo y dinero que requiere cualquier medio regenerativo; para eso me consultó un Perry, me contestó un galenero a quien aconsejé un circuito algo complicado (menos que éste) pero relativamente eficaz; pasó un año y volvió a la modesta galenita.

Todos los circuitos a galena que hasta el presente ensayé, selectivos como un Perry según sus promotores, me dieron resultados mediocres casados a veinte (20) cuadras de dos poderosas estaciones y no a cuatro o cinco y eso que mi antena es corta; me guardo por lo tanto de decir que el circuito que ofrecen colocado próximo a una estación sea capaz de eliminarla; pero sí sostengo que es lo más selectivo que en esta clase de circuitos pueda esperarse.

Resultados relativamente satisfactorios se obtuvieron con el circuito conocido por Renart y que en forma algo diferente fué publicado en esta revista hace más de un año.

En este circuito se emplea un condensador variable para sintonizar directamente una bobina colocada entre otras dos que corresponden a antena

y detector, más o menos rigidamente acopladas; en realidad los tres circuitos son sintonizados simultáneamente a causa del fuerte acoplamiento, aunque con bastante amortiguamiento; cuando por razones de selectividad las bobinas se separan, el amortiguamiento disminuye, pero los circuitos primario y secundario (llamaremos filtro a la bobina intermedia) pierden sintonía, mejor dicho, impedancia y el rendimiento disminuye bastante.

El circuito. — Ahora empecemos por sintonizar también primario y secundario y aflojemos considerablemente el acoplamiento; empleemos bobinas de poca resistencia total (pérdidas) y tendremos un receptor tan bueno como cualquiera podría desear.

Primario sintonizado: el único medio de obtener real transferencia de la frecuencia a recibir; la sintonía puede obtenerse por el usual condensador variable en serie con una inductancia de valor adecuado; en esta forma un condensador de 45 placas cubrirá toda la gama de Broadcasting, puede igualmente bien utilizarse un variómetro y en este caso quizá sea conveniente colocar en serie un condensador fijo tanto más pequeño cuanto más larga sea la antena e las condiciones de interferencia; la sintonía en paralelo (rejetor) no es satisfactoria en cuanto a selectividad.

En cualquier caso, pero especialmente si se utiliza un variómetro, conviene hacer el acoplamiento por medio de una bobina separada, de poco diámetro, dejando el resto del primario en posición no inductiva con el receptor.

Filtro y secundario: bobinas canasta de buen diámetro; el objeto de emplear bobinas canasta no es precisamente eliminar el tubo soporte, completamente inocente en frecuencias de broadcasting, sino reducir la capacidad distribuida y el efecto superficial (pelicular) responsables de la mayor parte de la resistencia total (pérdidas) de las bobinas; en cuanto al diámetro es para mantener cierta la longitud relativa; por una u otra razón, bobinas largas y de poco diámetro son, a pesar de emplearse menos hilo (proporcionalmente inverso al factor k.)

para una inductancia equivalente, más resistentes que bobinas de gran diámetro que llevan mucho más hilo; esto indica que dentro de límites razonables la resistencia del hilo es sólo una pequeña parte de la resistencia total de la bobina.

Cualquiera que sean las bobinas conviene darles un número de vueltas suficiente para sintonizar toda la gama de broadcasting con condensadores de 13 placas o capacidad equivalente; no hay inconveniente en utilizar condensadores mayores siempre que no se empleen a fondo; es decir, emplear siempre la mayor proporción de inductancia posible.

Acoplamiento: las bobinas van colocadas sobre el mismo eje longitudinal y separadas de diez a quince centímetros unas de otras; un acoplamiento cerrado no produce señales más fuertes y debido al amortiguamiento la selectividad disminuye; una vez hallado el acoplamiento correcto se fijan y toda la sintonía se obtiene por los condensadores.

La única ventaja de este conjunto es que prácticamente no se pierde sensibilidad para obtener la selectividad deseada; esta selectividad se consigue por un filtrado, podríamos decir; el primario deja pasar en parte otras frecuencias que la sintonizada, en proporción de su resistencia (interés en utilizar bobinas de baja resistencia). Ahora el filtro, libre del efecto amortiguador del detector y teléonos absorbe la frecuencia casi pura y la transfiere al secundario y un ajuste de la impedancia de este último trae la selectividad requerida. Es decir, que la frecuencia sintonizada pasa casi íntegramente de un circuito a otro, mientras las frecuencias indeseables son gradualmente desechadas.

Bien, el aficionado que construya este receptor, y muchos tendrán en su cajón de desechos materiales suficientes, se hallará en presencia de un neutrodyno (no rebajo nada) y si lo coloca en un amplio y estético cajón con los tres diales equitativamente distribuidos sobre el panel de madera lustrada imitación hakeita, con algún grabado alegórico, la ilusión será completa.

## ES EL ÚNICO!...

### PLUG Y JACK TRIPLE

Para la antena de cuadro del circuito "SUPER - HARTLEY"

### "PENDOLITA"

Marca Registrada

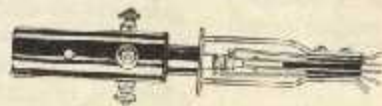

SOLICÍTELO EN LAS BUENAS CASAS DEL RAMO



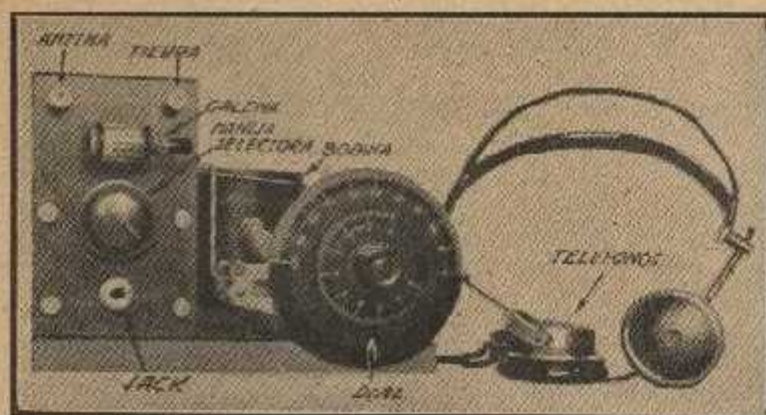

## Un receptor recomendable para el que se inicia

Dichos caños o listones, (este detalle no reviste importancia alguna), se erigirán sobre la azotea del edificio, si éste fuera de una o dos plantas, en cuyo caso deberán adosarse unos 0,50 metro de listón o caño, a una pared o caño de ventilación, sujetándolo luego por medio de lazos o tiros de alambre fuerte, y alternando en cada tiro, un trozo de alambre unido a un aislador, de los empleados anteriormente. De dicho aislador a otro trozo de alambre, de tal modo que queden varios aisladores intercalados alternativamente en la longitud total del alambre, empleándose, una vez así preparados, como lazos o tiros de sostén de los caños o listones. Véase figura 1.

La disposición sugerida en la figura 1 es, desde luego, una de las más comunes y fáciles de realizar, pudiéndose asimismo, utilizar sin ninguna clase de inconvenientes, cualquier caño de ventilación que se eleve sobre el techo del edificio, a una altura conveniente. De ser posible, aconsejo efectuar la bajada hasta el receptor, en una forma sensiblemente directa, es decir, sin

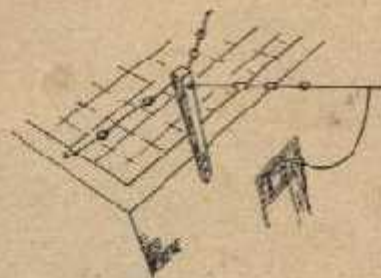

Fig. 1

obligar al cable de bajada, que deberá ser aislado en goma, a efectuar demasiadas vueltas y codas en su recorrido hasta el receptor.

La bajada deberá hacerse por el extremo de antena más próximo al aparato, con el objeto de evitar longitudes excesivas a dicho conductor. Puede adoptarse la dispo-

# Realización práctica de un receptor a galena

Por R. RIPAMONTI

Del Departamento Técnico I. T. T. E. P.

Inicio hoy, con éste mi primer artículo en RADIO MAGAZINE, al par que mi presentación a los lectores, una serie interesante de artículos dedicados única y exclusivamente al principiante, y también a aquellas personas que tengan interés en conocer las maravillas de la ciencia radioeléctrica. Comenzaremos, pues, por el más elemental receptor de radio: se trata de un receptor a galena; que cuidadosamente armado puede proporcionar excelentes resultados.

Las ventajas de este receptor son las siguientes: 1°. Pocos materiales necesarios para su armado; 2°. Sencillez extrema en su construcción y 3°. Casi todas las piezas empleadas en este pequeño receptor servirán para futuras construcciones. Empezaré por describir al lector el más importante complemento de todo receptor de radio, al mismo tiempo que una breve reseña sobre la función desempeñada por tan importante elemento, al que generalmente no se le reconoce en todo su valor su papel esencial en todo aparato de radiorecepción.

## La antena. Instalación

Para que alguna cosa se pueda llevar a cabo es necesario poseer el medio adecuado. Sabemos por propia experiencia que los sonidos son inaudibles sin la existencia de la atmósfera, lo cual es debido a la carencia del agente portador de las ondas sonoras, las que por un proceso fisiológico impresionan la membrana del oído humano. Exactamente lo mismo sucede en la radio: el medio de comunicación entre las distintas emisoras y nuestro receptor está constituido por el éter.

Explicado lo que antecede, pasemos a los detalles prácticos referentes a la construcción del elemento primordial de todo principiante en radio: la antena aérea. Está constituida, principalmente, por un solo hilo de cobre, de 15 a 20 metros de longitud, suspendido por medio de aisladores, formándose, de los extremos superiores de dos caños de hierro galvanizado o simplemente listones de madera, cuyo largo total no sea menor de 5 metros.



sición de la figura 2., aunque este detalle es absolutamente opcional, pero anticipo que en ciertas circunstancias puede resultar de una ayuda eficaz. En ningún caso se considerará como indispensable para el normal funcionamiento del recep-

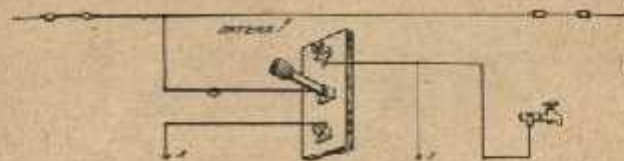

Fig. 2

tor, la disposición sugerida; ya hemos dicho que se trata de un detalle que queda por entero librado al criterio y conveniencias del lector.

No obstante su simplicidad, este dispositivo permite a la antena desempeñarse bajo otro aspecto, es decir, en un momento dado, puede convertirse muy fácilmente en un eficaz pararrayos, pues en caso de tormenta, bastará simplemente invertir la posición normal de la llave, la que según el diseño de la figura 2., es hacia abajo. Conviene aclarar, que con esta u otra disposición de antena, será de mucha utilidad una toma de tierra, efectuada a una canilla de agua corriente; si se está en el campo lo más práctico será hacerla a la tubería de la bomba de agua. El alambre de dicha toma de tierra puede ser aislado o desnudo. Por medio de una abrazadera, de metal, provista de tornillo con tuerca, se sujetará el alambre firmemente a la canilla o tubería, debiéndose raspar su superficie si ésta estuviere oxidada. En dicha toma de tierra pueden efectuarse todos los codos y vueltas necesarios para llevar el alambre hasta el lugar donde se encontrare emplazado el receptor, si bien esta disposición resulta prohibitiva en lo referente a la bajada de antena.

Si se ha seguido con cuidado las instrucciones antes consignadas y de la misma forma se ha contemplado su realización práctica, podrá pasarse ahora, directamente, a la construcción del receptor propiamente dicho, para lo cual se deberán adquirir los siguientes materiales y si es posible de buena calidad.

1 Detector a galena, del tipo encerrado en un tabito de vidrio.

30 metros de alambre esmaltado de 0,5 mm de diámetro, para la bobina.

1 Tubo de ebonita o bakelita, de 75 mm de diámetro y 75 mm de largo.

1 Manija selectora de cuatro contactos.

1 Jack, para los teléfonos.

1 Par de teléfonos de no menos de 1000 ohms de impedancia, por auricular.

1 Dial, del tipo micrométrico o vernier.

1 Condensador variable, de 23 chapas.

2 Bornes, para antena y tierra. Cable, soldadura, tornillos, arandelas, etc.

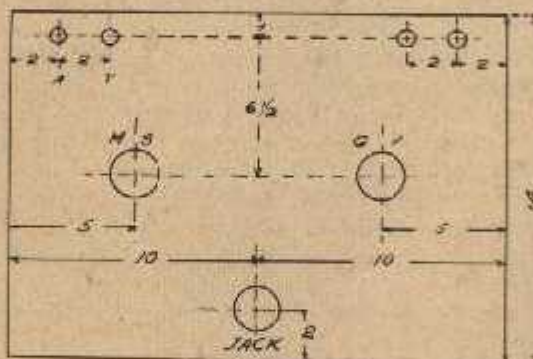

Fig. 3

Una vez provistos de estos materiales, sólo necesitaremos, como complemento, un trozo de madera de las medidas siguientes: largo 20 cm; ancho 13,5 cm; espesor  $\frac{3}{4}$  de pulgada; que será la base de este eficiente receptor.

Mediante escuadritas de aluminio, hierro, etc., uniremos a dicha base un panel de ebonita, o en su defecto, un tablerito de madera terciada, de 4 mm de espesor, 20 cm de largo y 14 cm de alto. Luego de haber unido, por medio de las escuadritas de metal, el tablero y la base, se le dará al conjunto así formado, dos o tres manos de goma-laca, disuelta en

alcohol, con el fin de preservar a la madera de los efectos de la humedad, y hacerla al mismo tiempo, más aislante; si por cualquier razón no se pudiera emplear ebonita o bakelita para el tablerito del frente del aparato.

Si se desea aprovechar dicho tablero para las sucesivas construcciones, que se irán publicando oportunamente, deberán efectuarse los agujeros para los accesorios, de acuerdo a las medidas especificadas en la figura 3.

Las referencias de dicha figura son las siguientes:

A.; Antena T.; Tierra  
M.S.; Manija Selectora  
C.V.; Condensador Variable

Una vez colocados estos accesorios en el panel, (tablero frontal), procederemos a construir la bobina,

poniendo en ello el mayor cuidado, por ser éste uno de los elementos principales del receptor. En primer lugar procédase a dividir en dos rollos el alambre adquirido para la bobina, uno de los cuales tendrá un largo de 14,5 metros, y por consiguiente el otro rollo tendrá una longitud de 15,5 metros. A 1,5 cm del borde del tubo de bobina, haremos un agujero, por el que

pasaremos un tornillito con tuerca, de tamaño adecuado, sujetando por medio de dicho tornillo uno de los extremos del alambre, habiéndole quitado previamente el esmalte a fin de obtener buen contacto.

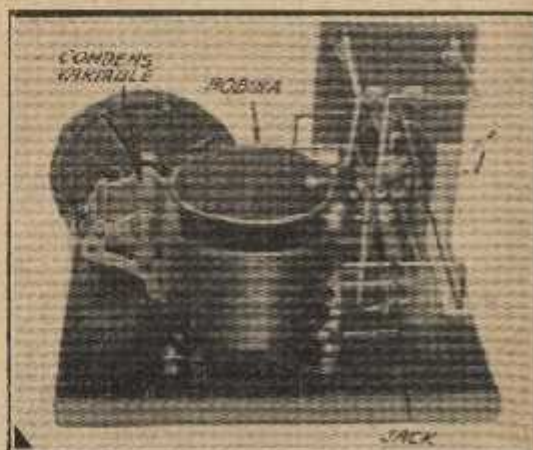

Vista de atrás del receptor terminado



Este bobinado, que lo comenzaremos directamente sobre el tubo, lo llamaremos «primario». Se bobinarán entonces, 65 vueltas de dicho alambre, teniendo especial cuidado de que no se encimen las espiras

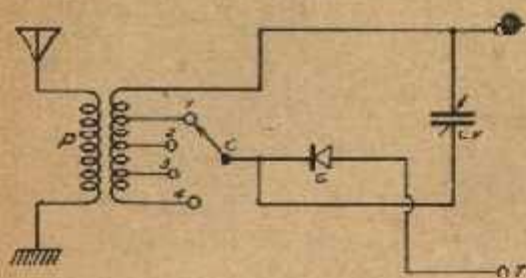

Fig. 4

unas con otras, es decir, que formen una capa de alambre lo más lisa posible, evitando al mismo tiempo la formación de nuditos en el mismo. Al terminar la última vuelta de este bobinado, déjense unos 10 cm más de alambre, a fin de sujetarlo en la misma forma que se hizo al comenzar. Terminado esta operación, conviene darle al conjunto, una o dos manos de goma-laca con el objeto de que las espiras se mantengan juntas.

Péguese ahora, por medio de cola líquida o con la misma goma-laca una tira de papel de seda que cubra el bobinado completamente; una o dos capas de este papel serán suficientes. A 1 cm del borde del tubo, y en un punto opuesto por el diámetro, al comienzo del primario, hágase un agujero, de tamaño adecuado, a fin de sujetar mediante otro tornillito con tuerca el principio de este segundo devanado, tal como se hizo anteriormente. Este bobinado constará de 60 vueltas y 4 derivaciones, tomadas a 15 vueltas cada una, sin contar el borne del comienzo.

Así, pues, se bobinarán 15 espiras y al terminar éstas, sin cortar el alambre, haremos un ojalito, siguiendo luego en esta forma hasta completar el número de espiras requerido. Quedarán, pues, cinco contactos, es decir, el punto común de comienzo del bobinado y las 4 derivaciones antes mencionadas, las que permitirán, por medio de la manija selectora, intercalar en el circuito del receptor, distintas porciones del secundario. Una vez concluida la bobina, ésta deberá

presentar siete bornes; dos de los cuales pertenecen al primario y los cinco restantes al secundario.

La bobina puede sujetarse a la base mediante tres angulitos de metal, situados en la periferia del tubo y en forma equidistante. Puede procederse ahora a efectuar las conexiones del receptor, para lo cual se usará alambre de 1 mm de diámetro, preferentemente rígido, el cual en los sitios donde debe soldarse, será cuidadosamente raspado y pelado, a fin de obtener de este modo buenas soldaduras, considerándolas mecánicamente y eléctricamente. Las uniones se harán de acuerdo al siguiente orden: Borne de antena al comienzo del primario; borne de tierra al final del mismo; un terminal de galena a condensador variable y de este punto al polo fijo de la manija selectora.

Dicho polo fijo es el polo común a los otros en las cuatro posiciones; las cuatro derivaciones del secundario a los cuatro polos de la manija selectora; de las chapas móviles del condensador variable al comienzo del secundario y de este

producirse errores, siempre, claro está, que se hubiere leído detenidamente el texto de este artículo.

Una vez efectuadas todas las conexiones del receptor, conéctense la antena, la tierra y los teléfonos, buscando entonces un punto sensible en la galena, en el cual se escucharán las distintas emisoras, naturalmente que algo mezcladas entre sí, pero haciendo girar la perilla de la manija selectora y la del condensador variable, se podrán separar en forma aceptable. Es éste, un defecto muy corriente en este tipo de receptores, si bien en el que se describe en este artículo, se ha tenido en cuenta obtener una buena selección de broadcastings. En una próxima publicación, daremos el circuito de un receptor a válvula, para pilas y baterías, del tipo regenerativo, también para audición sobre teléfonos, pero mucho más selectivo y de mayor potencia.

En el local de la Administración de RADIO MAGAZINE, está expuesto, para los lectores que deseen observarlo, el modelo construido por el autor, donde podrán apreciar personalmente los detalles de su construcción. Sólo me resta entonces, desearles pleno éxito en la realiza-

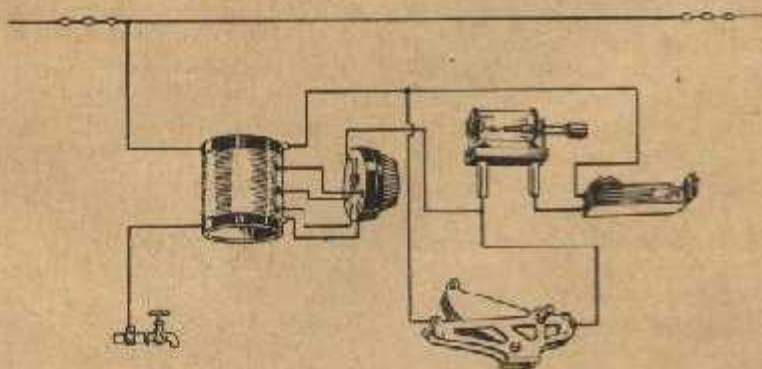

Fig. 5

punto, a un polo del jack de teléfonos; por último el otro polo de la galena, al otro polo del jack. Para mayor claridad consúltese el circuito del receptor, ilustrado en la figura 4, y en la figura 5, están representadas las piezas que lo componen, en forma esquemática. Mediante dichas figuras, y las explicaciones anteriores, no pueden

ción del receptor, no obstante lo cual, si para algún lector las explicaciones contenidas en el texto no fueran lo suficientemente claras, quedamos gustosamente a la espera de su grata consulta, dirigida a nombre del autor o a la sección «Correspondencia» al domicilio de la REVISTA, Perú 165, Capital Federal.



# Wide Range BANDPASS CRYSTAL TUNER

*Construction details on a novel 540 to 1750 kc. crystal tuner. It has 12 to 18 kc. selectivity without using any vacuum tubes or power supply.*

By

**JOSEPH M. BOYER, W6UYH**  
Consulting Engineer



Over-all view of laboratory "breadboard" test set along with its audio amplifier and speaker. The volume control was eliminated in this broadcast band tuner. The one in the audio amplifier is being used in its place. Circuit diagram is shown on Page 112.

**T**HE old-fashioned crystal set is dead—let it go to a well-earned rest. This article will not be another description of the same weary circuit with a modern germanium crystal detector substituting for the "cat whisker" and galena. The broadcast band tuner to be described is capable of 12 to 18 kilocycle selectivity, without benefit of vacuum tubes or power supply. It contributes no additional hum to the amplifier following it and is free of the heterodyne whistles present in superheterodyne tuners.

Simple in construction, the unit can be built for a total cost of seven dollars and a time investment of one or two hours; or the tuner may be "dolled up" with the addition of a slide rule dial and 10 kc. anti-ringing filter for a total of twelve dollars. Connected to a modern high-gain amplifier in a typical American metropolitan area, its performance is indistinguishable from that of many high priced t.r.f. and superheterodyne high-fidelity tuners.

The original model was specifically designed for a large advertising agency, to serve as a fixed frequency, high-quality monitor for spot radio show checks. Later laboratory tests showed it capable of excellent performance over the entire broadcast

band. There is nothing tricky or unusual about the circuit used. It is one of the many well-known bandpass networks with which radio engineers have been familiar for years. The characteristics of such a network are a relatively "flat top" for uniform response over the desired channel and very steep sides or "skirts" to provide good selectivity between adjacent signals. Reference to Fig. 1 will show that special so-called bandpass coils have not been used. Instead high "Q" litz wire r.f. coils, possessing a primary and secondary winding, have been incorporated into the circuit. The primary reason for this is that coils designed for t.r.f. bandpass tuners consist of a single winding usually intended to work into an infinite impedance detector to avoid loading down the network.

In the circuit shown in Fig. 1, severe loading of the output terminals of the bandpass network was avoided by utilizing the J. W. Miller 242 r.f. coil,  $T_2$ , backwards; that is, the primary is used as the output winding and carries the crystal current of the 1N34. This provides a stepdown from the high impedance of the network to the relatively low impedance of the crystal circuit. While the turns ratio and coupling coefficient are not ideal for the

purpose, they are sufficient to give good results. A negative mutual coil  $T_2$  and condenser  $C_2$  complete the bandpass circuit.

Only one caution with regard to circuit values need be stressed, and that is to make sure condenser  $C_2$  is .015 mfd. even if two condensers of standard values have to be paralleled to get this value. While not shown in the illustrations, two precautions in construction were found necessary to avoid hum pickup from random fields. A well bonded bottom plate must be used on the chassis and a double shielded cable, such as war surplus RC5/U, provided to couple the tuner to the amplifier input. With the measured hum level of many good amplifiers down 65 db. and a gain sensitivity of 125 db., such measures are necessary to secure the performance of which the tuner is capable.

It should be pointed out that unlike the familiar crystal set, the tuner described herein is not intended to drive a pair of earphones. Networks of the bandpass type have a given insertion loss, and hence require quite high gain amplifiers to be used in conjunction with them. Another fact which came to light during measurements of the bandpass characteristics of the tuner is that the particular coils used, when placed in the circuit shown in Fig. 1, only give satisfactory 18 to 20 kc. "flat top" response when from 30 to 50 feet of wire is used for an antenna. This is not due to the "pickup" efficiency of such length of wire, but is due rather to the reactance that this antenna places across the input terminals of the network.

Many readers may think this is getting a little fancy with a crystal set, but judgment in this respect should be withheld until the experience of tuning the broadcast band with this unit has been enjoyed. Also note that 18 to 20 kc. selectivity has been mentioned repeatedly. Neither this tuner

(Continued on page 112)



## Crystal Tuner

(Continued from page 31)

nor any other really high-fidelity receiver can separate stations operating closer than this, for such bandwidth is needed for high program quality transmission.

In aligning the tuner, the really ideal instruments for the job are a bandsweeping signal generator used in conjunction with an oscilloscope. In lieu of such aids, however, a 250  $\mu$ fd. condenser should be connected to the antenna post of the tuner, and the lead from a regular signal generator connected to it. The signal generator should share a common ground with the tuner. A 20-watt resistor of a value equal to one of the higher (250- or 500-ohm) output impedances provided by the amplifier is placed across the voice coil terminals in place of the speaker. The output meter, in our case a model 260 Simpson set to the 2.5 volt a.c. scale, is placed across this resistor. With the tuner connected to the amplifier input (at least 50 to 80 decibels gain should be available) the gain control is advanced to about one eighth its full scale setting. Any noise or hum within the amplifier will cause the meter to read. The voltage indicated should be noted as being the "base line" or reference level for subsequent readings.

The modulated signal generator is now tuned to approximately 900 kc. and the tuning condenser of the tuner rocked back and forth to find the signal. Once such a point has been found, the output attenuator of the signal generator should be adjusted until the output meter reads just full scale on the peak response of the signal. Adjust trimmers  $C_{11}$  and  $C_{12}$  until, upon

tuning through the signal, two slight peaks or rises are noticed on each side of the signal generator's frequency. These peaks should be made equal to each other by careful adjustment of the trimmers; this is the proper alignment. The antenna may now be connected and the speaker replaced for an actual air check.

If no signal generator is available, the tuner may still be aligned, at the expense of a little sleep, by waiting until the hour most broadcast stations end their regular programs. It will be found usually that several return to the air in the early morning hours, emitting a steady tone-modulated signal for transmitter adjustments. With such signals available it is then a simple matter to follow the procedure outlined above.

If it is found impossible to make the two slight peaks each side of the center frequency equal in magnitude, the bottom plate of the chassis should be removed and the wires leading from the "grid" connection of each J. W. Miller r.f. coil slowly moved with an insulated probe. It will usually be found that this has an appreciable effect upon the magnitude of the first or second peak. The lead found to have the major effect should be bent away or nearer to the metal chassis and the trimmers adjusted until the two peaks are matched.

So called "monkey chatter" may be noticed when listening to one or more stations in a given locality due to interchannel interference. This effect may also take the form of a very high-pitched ringing sound. If this interference is objectionable, T. should be added to the circuit. This filter is an iron core, parallel-tuned circuit, which should be tuned while listening to a signal until the "chatter" is eliminated.

Fig. 1. Schematic diagram of the low-cost bandpass crystal tuner.

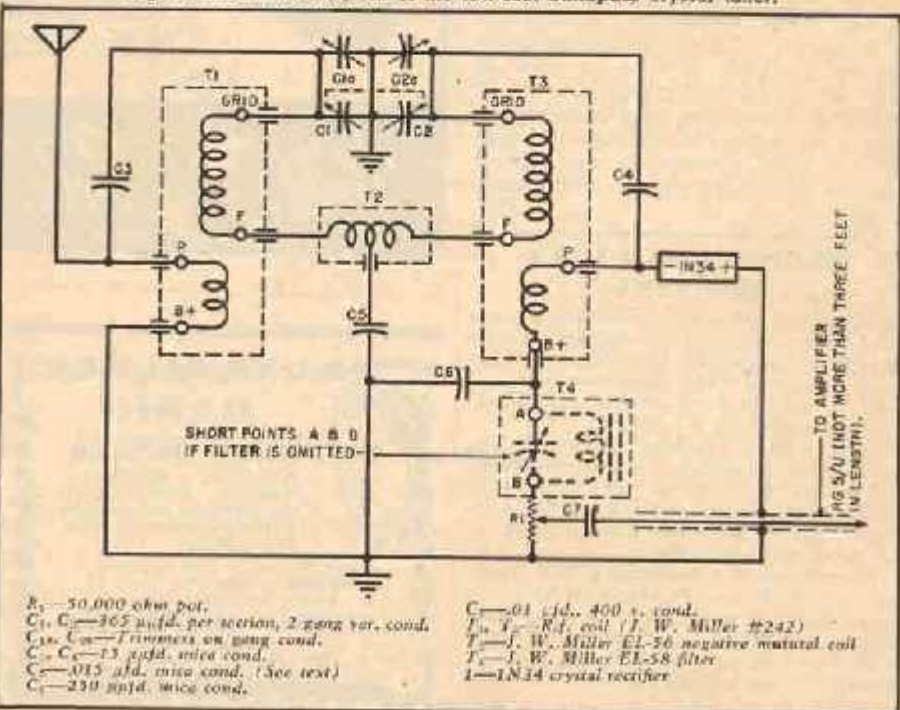



RADIO

 Por el Profesor  
**JOSE SUSMANSKY**

# EL "HOBBY - 53"

## Efficiente receptor a galena para teléfonos

A pesar de haberse publicado, a través de estas páginas, una serie de receptores a galena, los lectores no dejan de insistir sobre el mismo tema esperando ver coronados sus deseos con otros circuitos cuya eficiencia sea superior a los ya conocidos por ellos.

Por las razones expuestas es que nos pusimos a "trabajar" nuevamente para complacer a los amantes de los receptores que recuerdan la época de gloria de la radio, cuando las recepciones de radio debían hacerse en el absoluto silencio...

Veamos lo que damos a conocer a nuestros lectores como un diseño más o menos trabajado a fin de obtener la mayor eficiencia y al mismo tiempo lograr una selectividad que nos permita escuchar las estaciones sin que una moleste a la otra.

Anteipamos que los resultados serán ampliamente satisfactorios si se atienden a las indicaciones que se dan en cada uno de los distintos gráficos. Además, para que los resultados sean realmente los esperados, se agrega un desarrollo completo del receptor a fin de que cada uno de los lectores que desean armar un receptor por primera vez lo puedan realizar sin correr el riesgo de equivocarse y así perder el entusiasmo por una tarea tan grata.

Los elementos necesarios para la construcción del receptor son sumamente reducidos, pues casi alcanzan los dedos para contar todas las partes que lo componen. Son necesarios dos condensadores variables de 17 chapas que probablemente los encontrarán en algún cajón de un amigo dedi-

cado a la radio o bien en alguna casa del ramo; una bobina de construcción casera cuyos detalles indicamos en la figura res-

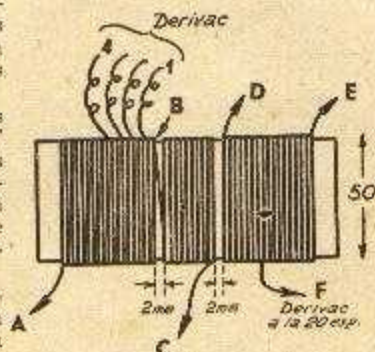

**-BOBINA-**

-Debe usarse alambre ByS 22 ó  
0,64 mm. esmaltado.-

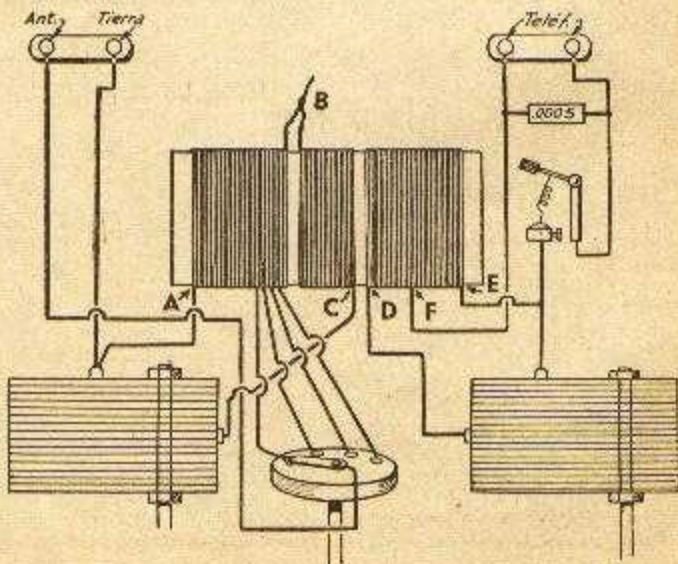

pectiva; dos tableritos, uno para toma de antena y tierra y otro para los teléfonos, una llave selectora y una galena con sus soportes "bigote de gato", etc. Además, necesitamos una base de madera terciada y pintada al óleo o con gomalac o preferiblemente una plancha de ebonita o bakelita sobre la cual se montarán todos los elementos necesarios para la construcción del receptor.

Para la fijación de los controles pueden usarse ya esquadritas como así también un panel del mismo material indicado para la base del receptor mismo.

Los teléfonos que se emplearán podrán ser de cualquier tipo teniendo cuidado de asegurarse que su estado sea bueno, si no se correrá el riesgo de realizar re-



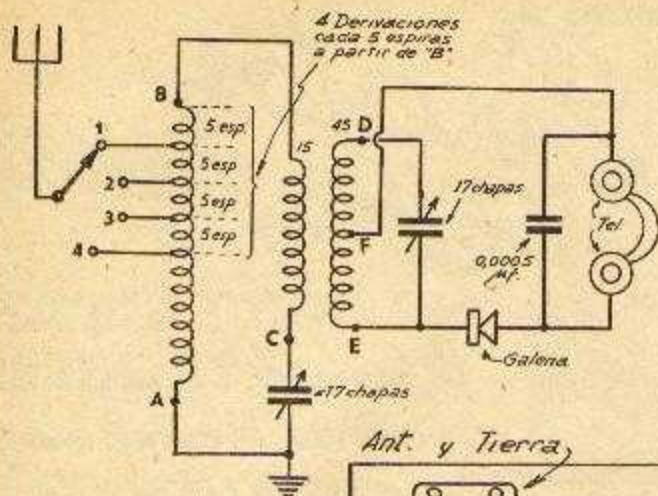

sintonía y de ajuste de señal y así insistiremos hasta lograr que la estación deseada se escuche sin ninguna clase de interferencias. Si aún así no se lograra buena recepción, aconsejamos buscar otro punto en la galena. Lo mismo puede hacerse si la señal deseada se escuchara muy débilmente.

Por lo general, el ajuste del receptor puede darse por terminado toda vez que se consiga para una posición determinada del "bigote de gato", en la cual pueden escucharse casi todas las estaciones con mucha intensidad. Si se quiere evitar el ajuste

cepciones débiles y se creará que es culpa del receptor. No sería la primera vez que un receptor a galena deja de funcionar debido a fallas en los teléfonos. Si se pudiera obtener alguno del tipo de cristal sería ideal, ya que además de su elevada sensibilidad se obtendrá una buena calidad de sonido.

Una vez verificadas las conexiones y teniendo la certeza de la corrección en las soldaduras, etc., conectaremos la antena y la toma de tierra en las bornas respectivas. Nos calzaremos los teléfonos y haremos girar el dial del condensador de sintonía hasta lograr alguna señal. Una vez logrado esto, haremos girar el dial del ajuste de la señal hasta que ésta se escuche con máximo volumen. Si dicha señal se escuchara molestada por otra estación se pasará la llave selectora

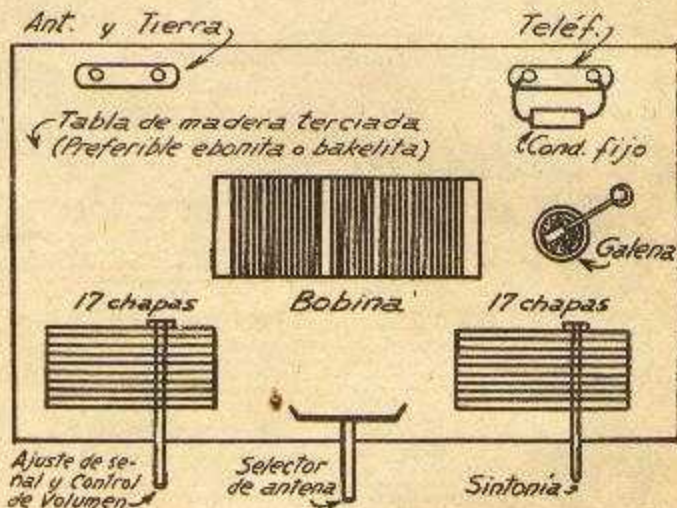

### - DISTRIBUCION de MATERIALES -

a otro punto, que corresponde a otra derivación de la bobina y volveremos a retocar el dial de

del "bigote de gato" podría emplearse una galena "carbonúndum", especial para estos usos, la cual elimina el "bigote de gato" indicando y hace del detector un elemento fijo.

Sólo agregaremos ahora algunos detalles sobre la antena y la toma de tierra a fin de asegurarse una buena recepción.

La antena, para que sea eficiente, debe estar muy bien montada, es decir, a una altura respetable del suelo y por ende

**ACADEMIA de**  
**ENCUADERNACION**

**"HOBBY"**

**APRENDA**  
**ENCUADERNACION**

**CLASES PRACTICAS PARA PRINCIPANTES, TODOS LOS MARTES Y VIERNES A LAS 18.30**

**CUOTA MENSUAL: TRES PESOS**  
**VENEZUELA 668 — Bs. Aires**



lo más alejada del techo, sobre todo si es de chapa de zinc.

Además, es fundamental que la aislación de la antena con respecto a sus soportes sea lo más buena posible. La bajada de la antena deberá ser soldada a la antena; si los soportes no son del mismo alambre, la bajada de antena deberá también estar aislada correctamente evitando que pase cerca de cualquier pared y si tuviese, por razones especiales, que tocar la pared en algún punto deberá colocarse un aislador. Si la bajada ha de atravesar

una pared o una puerta deberá emplearse una boquilla de porcelana a fin de que el alambre de la bajada esté aislado de cualquier parte que pueda ponerla en cortocircuito a tierra en casos de humedad.

Respecto a la toma de tierra, debe adelantarse que en ningún momento la cañería de aguas corrientes resulta ideal, y se empleará en los casos en los cuales no existe otro remedio, pero en cuyo caso debe soldarse el cable de la toma de tierra al caño respectivo y además el diámetro del

alambre deberá ser superior a dos milímetros y no deberá tampoco ser excesivamente largo.

Una buena toma de tierra la constituirá una plancha de metal o un tanque de metal enterrado a más de un metro de profundidad de tierra húmeda y cuya conexión se hiciese mediante cables de mucha sección y la distancia entre la toma de tierra y el receptor sea muy pequeña.

Estimados lectores, será entonces hasta la próxima, y buena suerte.

## FILATELIA

y \$ 1.80. Todos los tipos llevarán además de la indicación de su valor, la inscripción siguiente: "CORREOS DE CHILE". Centenario de O'Higgins - 1842-1942".

### FRANQUEO DE LA CORRESPONDENCIA

Se agradecerá a los lectores que nos envíen correspondencia tanto con mensajes de canje como con preguntas para el Correo, franquear sus cartas con sellos conmemorativos o aéreos, ya que los sellos servirán para darles utilidad en un concurso que se realizará próximamente.

El uso de sellos conmemorativos y aéreos en la correspondencia es una buena costumbre que beneficia al destinatario, sin aumentar los gastos del remitente.

Haga, pues, una costumbre fran-

queando su correspondencia con valores conmemorativos y aéreos.

A los coleccionistas del norte de nuestra América, indicamos remitir su correspondencia por vía aérea, ya que ello los beneficiará, pues la correspondencia marítima llega muy retrasada y los avisos de canje dejan de tener efectividad.

### AVISO DE CANJE N.º 2000

Publicamos en este número el aviso de canje N.º 2000, lo que había por demás en lo que se refiere a la gran cantidad de aficionados a la filatelia que lee nuestras páginas.

La popularidad que esta afición está adquiriendo cada día, es fiel reflejo de lo que los mensajes de HOBBY nos manifiestan.

Esperemos, por lo tanto, que a la llegada del N.º 3000 estemos en un mundo de paz y que por lo tanto la filatelia pueda adquirir todo el des-

arrollo que merece, por su obra cultural e intelectual.

## GALERIA DE HONOR

Damos publicidad a la fotografía del Sr. Mario Sandoval M., de Santiago de Chile, integrante de la Lis-



ta de Oro, a la que ha llegado merced a sus dotes de buen cajista y excelente caballero.

## SOLICITAN CANJE FILATELICO

2009. — Hasta 50 Sud y Centro Americanas, doy igual cantidad de peruanas o 20 o 20 más en universales a elección. L. Alvarez, Apartado 2095, LIMA.

2010. — Canjea cantidades 50, 75, 100 ó 125 estampillas peruanas diferentes por igual cantidad de cualquier país americano. Envíos certificados. Inconverso Emilio Tupaud, Apartado 89, CAJAMARCA.

2011. — Joven estudiante peruano desea

canje de sellos, fotos, revistas, ambos sexes. Respuesta inmediata. — Isabel Olivares F., La Victoria, Av. Sáenz Peña 982, LIMA.

2012. — Principiante avanzando desea canjear enviar de 25 a 30 de su país y recibirán igual cantidad del mio. — Oscar Cárdenas Rascho, HUANCAYO.

2013. — Envíen de 30 a 40 estampillas de su país y recibirán igual cantidad del mio. Contestación a vuelta de ca-

2010. — J. Rafael Salas Mantilla, calle 7.º N.º 206, SAN CRISTOBAL.

2014. — Envíen hasta 60 sellos de su país y recibirán igual cantidad del mio. — Francisco A. Flores, C. Carrera 13 N.º 206, SAN CRISTOBAL.

2015. — Solicito Argentina: Minilateral (sin peso); Uruguay, aéreos y conmemorativos; Paraguai y Guaytemala, Yvert 1941, Scott 1942. Correspondencia preferente aérea. — Enrique A. Pimentel, Fe a Esperanza 25, CARACAS.

VENDO colección "HOBBY", números 11 al 85, en perfecto estado.

\$ 30.—

GONZALEZ - Goya 678 - CAPITAL

COMPRO Revista "HOBBY", números 42 - 43 - 44 - 45 - 46 - 49 - 50 - 51 - 52 - 54 - 55 y 61. Ofertas al:

JOSE CAPRA

Av. 9 de Julio N.º 967, piso 3. Dp. 28  
Buenos Aires

VENDO Colección "HOBBY", números 17 a 86, por \$ 15.—

ANTICO - Piedras 682 - CAPITAL



## RECEPCION - DISTINTOS DISEÑOS DE RECEPTORES A GALENA

En la figura 104 se presenta un diseño simplificado de un receptor de galena que es de gran utilidad para el principiante y consta de una inductancia  $L$  de unos 250  $\mu\text{h}$ , un condensador variable  $C$  de una capacidad de

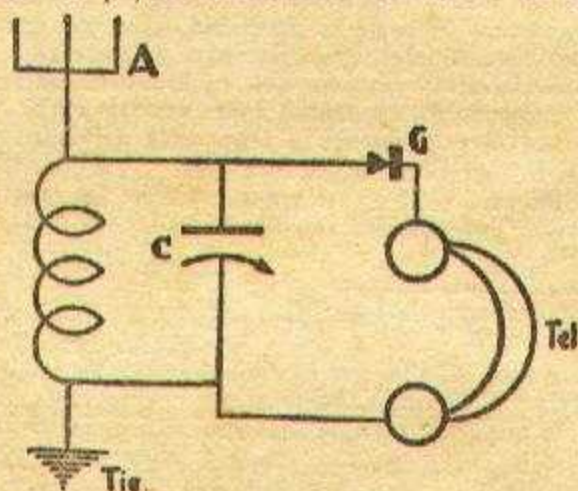

Fig. 104

0,00035  $\mu\text{f}$ , una galena  $G$  con su respectivo soporte y "bigote de gato", un teléfono  $Tel.$  del tipo empleado en radio, de unos 400 Ohms, por ejemplo. Además, se necesita, para el buen funcionamiento del receptor, una buena antena (larga y bien aislada) y una buena toma de tierra (lo más corta posible).

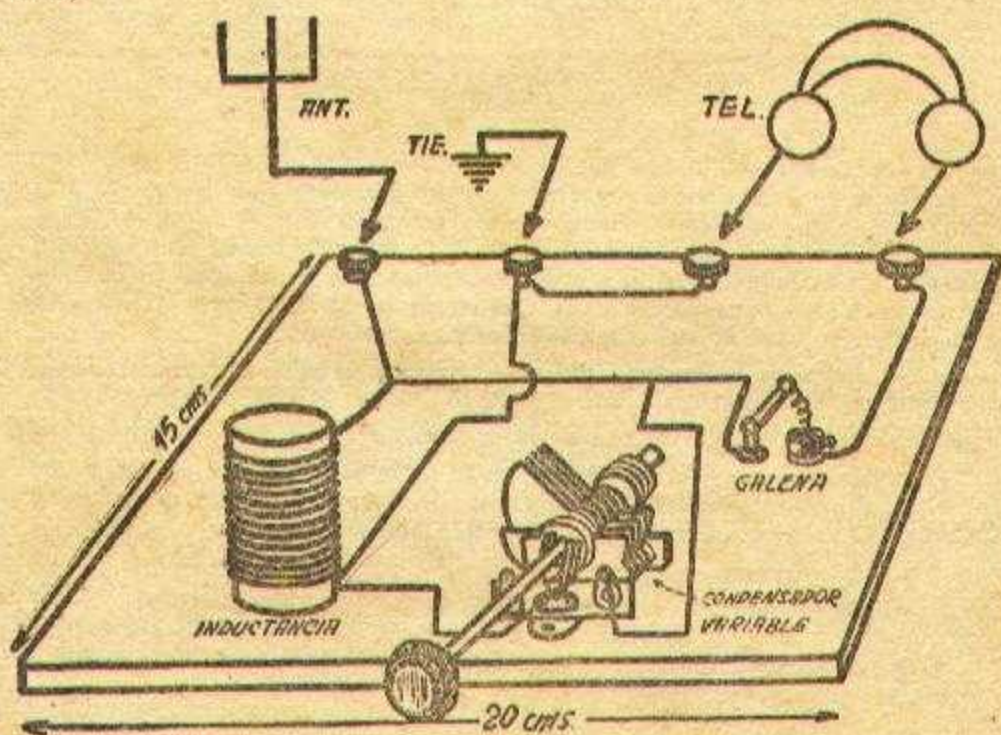

Fig. 105



Todos los elementos que componen el receptor propiamente dicho podrán ir montados sobre una tabla cuyas dimensiones se dan en la figura 105 y donde además se indican las conexiones, entre los elementos y las bornas para la antena, tierra y teléfonos respectivamente.

Conviene calcular previamente la inductancia que se emplea en este circuito y darle las dimensiones que cada cual creyera más conveniente y, si fuese posible, construir dos o tres del mismo valor, pero de distintas dimensiones, a fin de elegir entre ellas la más conveniente o sea la que mejor funcione.

El armado no requiere enclavados especiales. Bastará seguir el desarrollo de la figura 105. Se notará en su funcionamiento que la selectividad, es decir, la propiedad de "separar" una estación de otra, es débil. Por lo tanto, será conveniente buscar una disposición y dimensión especial para la inductancia  $L$  que será distinta para cada caso particular debido a que las antenas, las tomas de tierra y el lugar de recepción son distintos para cada caso.

El condensador variable nos permite sintonizar las estaciones que se encontrarán a distintas posiciones del mismo.

Aconsejamos al experimentador que deje constancia en un cuaderno de notas de todas las observaciones, cálculos y resultados obtenidos para cada experiencia realizada, pues dichas anotaciones son de un inapreciable valor para el caudal de sus conocimientos.

En la figura 106 presentamos otro modelo de receptor a galena, pero de diseño más avanzado que permita obtener mayor selectividad y quizás ma-

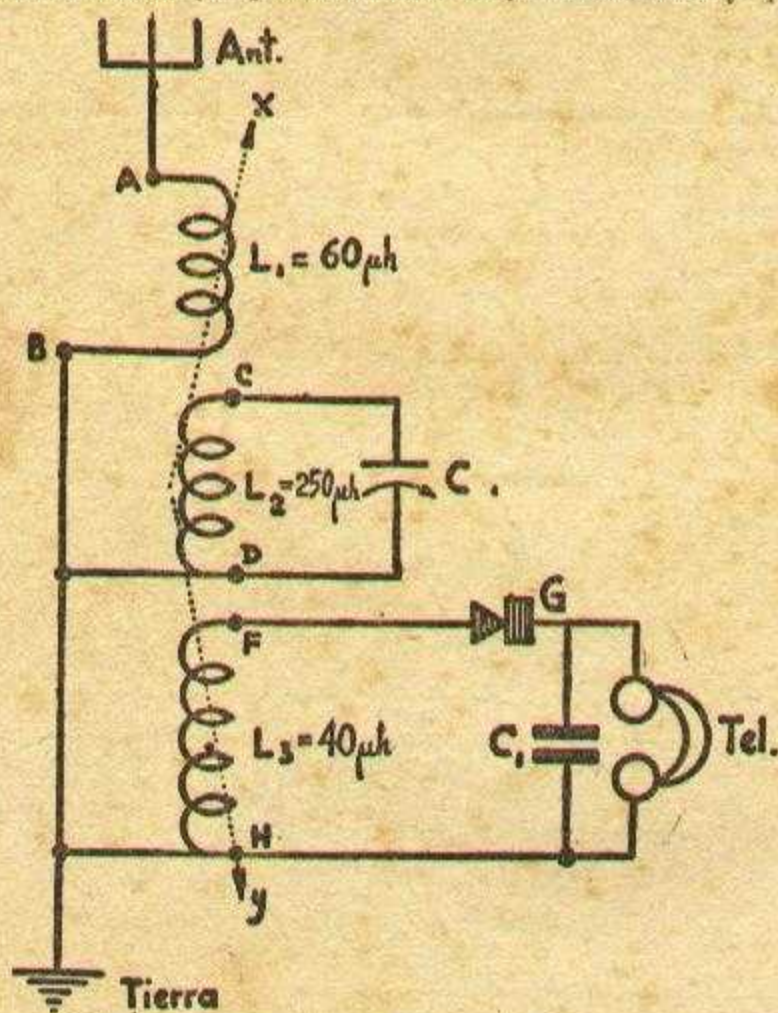

Fig. 106



por rendimiento en lo que a volumen se refiere. Dicho receptor tiene 3 bobinas  $L_1$ ,  $L_2$  y  $L_3$ , siendo fija la  $L_2$  que podría estar bobinada sobre un tubo de unos 10 cm. de diámetro. Las  $L_1$  y  $L_3$  se fijarán por su diámetro a dos ejes

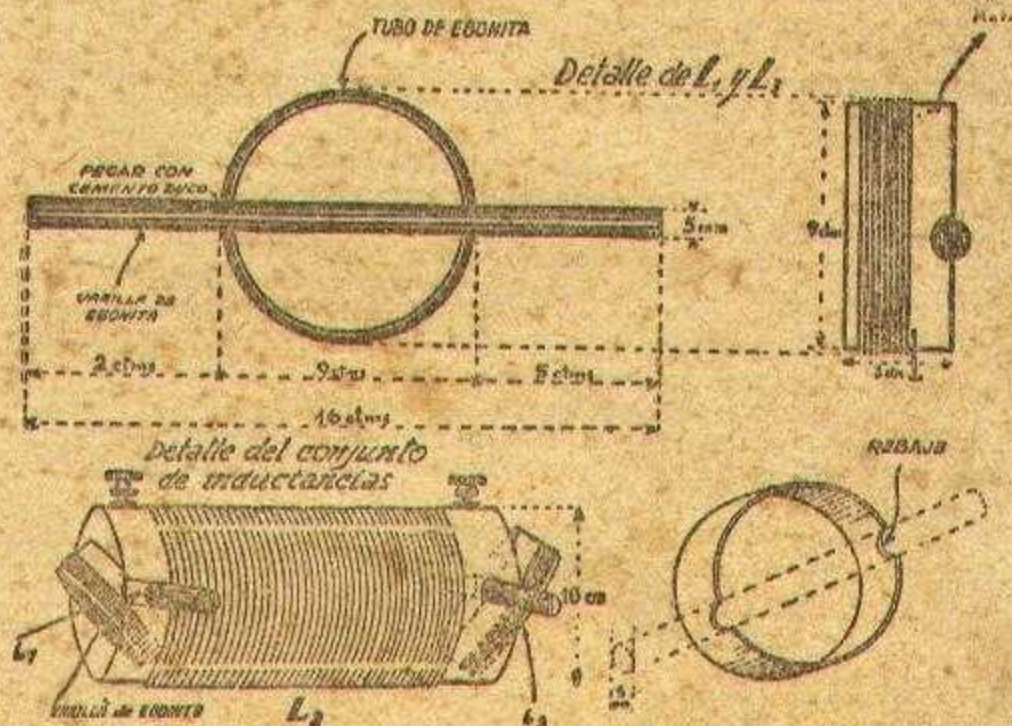

Fig. 107

distintos de material aislante (ebonita, bakelita, etc.), en la figura 107 se dan todos los detalles de la preparación de la inductancia. Estos dos bobinados van dispuestos a ambos lados de  $L_2$ , y sus diámetros deben ser inferiores al de  $L_2$ , de manera que cuando  $L_1$  y  $L_3$  tendrán que colocarse en posición ho-

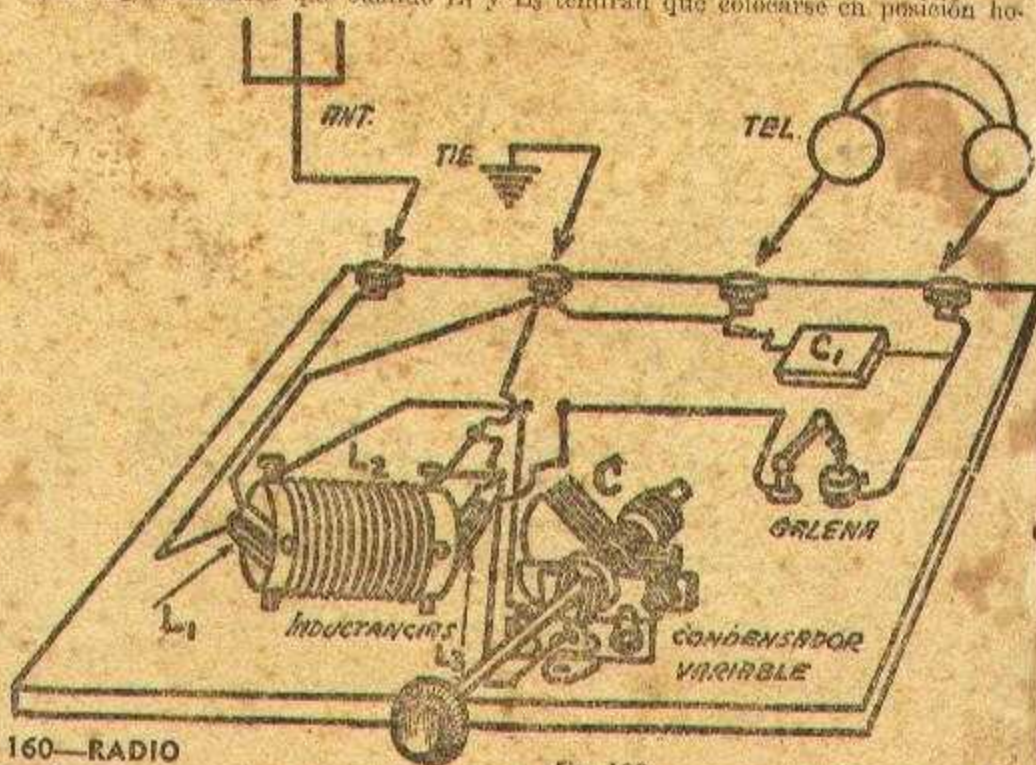

Fig. 108



horizontal por razones de sintonía, parte de ellas quedarán dentro del espacio de  $L_2$ . Las inductancias de las bobinas serán de los siguientes valores:

El condensador C tendrá una capacidad de 0,00035  $\mu\text{f}$ , o sea unas 17 placas en total. La galena, como los teléfonos, la antena y la tierra pueden ser los mismos que para el receptor anterior y C, de 0,0005  $\mu\text{f}$ . La figura 198 indica cómo deben realizarse las conexiones y la disposición de los elementos y el detalle de los bobinados, sin que por esto sea necesario ajustarse estrictamente a la disposición de la figura 108. El manejo de este receptor es muy simple. Se trata de sintonizar una estación, por ejemplo, por la mitad del dial, o sea en la posición media del condensador variable, logrado esto se hace girar lentamente primero  $L_1$  hasta obtener el máximo de volumen y selectividad y luego  $L_2$ . Si la estación que se desea recibir está molestada por alguna otra muy próxima, se gira  $L_1$  de manera que la bobina quede casi horizontal. Entonces se reajusta  $L_2$  y de esta manera queda el receptor en condiciones óptimas de recepción. Por lo dicho, se ve que la construcción y manejo de este receptor son muy sencillos. El alcance que puede lograrse con este aparato puede llegar hasta unos 100 km., siempre que la antena y la toma de tierra sean buenas.

---



Both young and old radio buffs usually start out with a crystal set . . .

# OATMEAL BOX CRYSTAL

**Fig. 1**

Sliding contacts made from brass and steel.

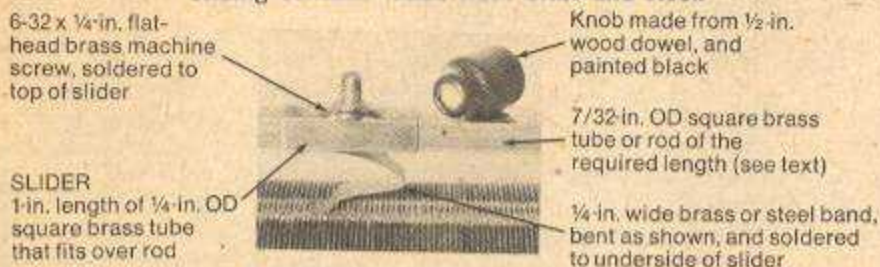

**Fig. 2** Antenna and ground end of the Quaker Oats radio.

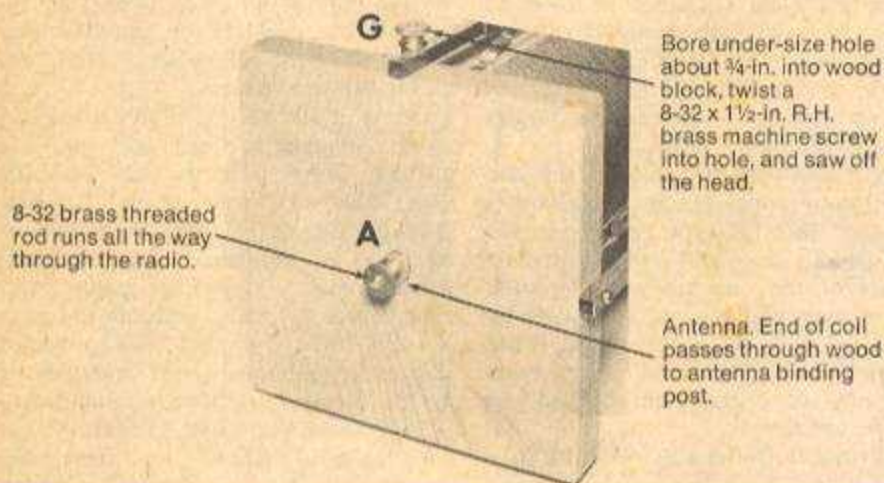

**A**SK JUST about any radio old-timer, including this writer, and he will probably tell you that his first radio was a home-brew slide tuning coil wound on an oatmeal box, a cat whisker and galena crystal detector, and a pair of earphones. This picture shows how to make such a radio, and it looks much like the writer's first radio built not long after World War I.

First, make the coil. Remove the two end covers from an 18-ounce, round Quaker Oats box, and cut the tube to a length of about 6 1/2-in. Give the tube a coat of shellac inside and out to moisture-proof it.

The writer used #21 single-cotton-covered enamelled copper magnet wire, and after the coil was wound the cotton was colored green by painting it with India ink to make it look like the old-time green silk-covered wire which is no longer being made. If you prefer, use #20 or #21 enamelled or nylon-coated copper magnet wire, and one pound should easily do it.

**Get Going.** Punch two small holes through the tube at each end, about 1/2-in. from the ends, to anchor the ends of your coil. To do a tight, smooth and neat job of winding the coil, tie the end

**Fig. 3**

Crystal detector end of the Quaker Oats radio.

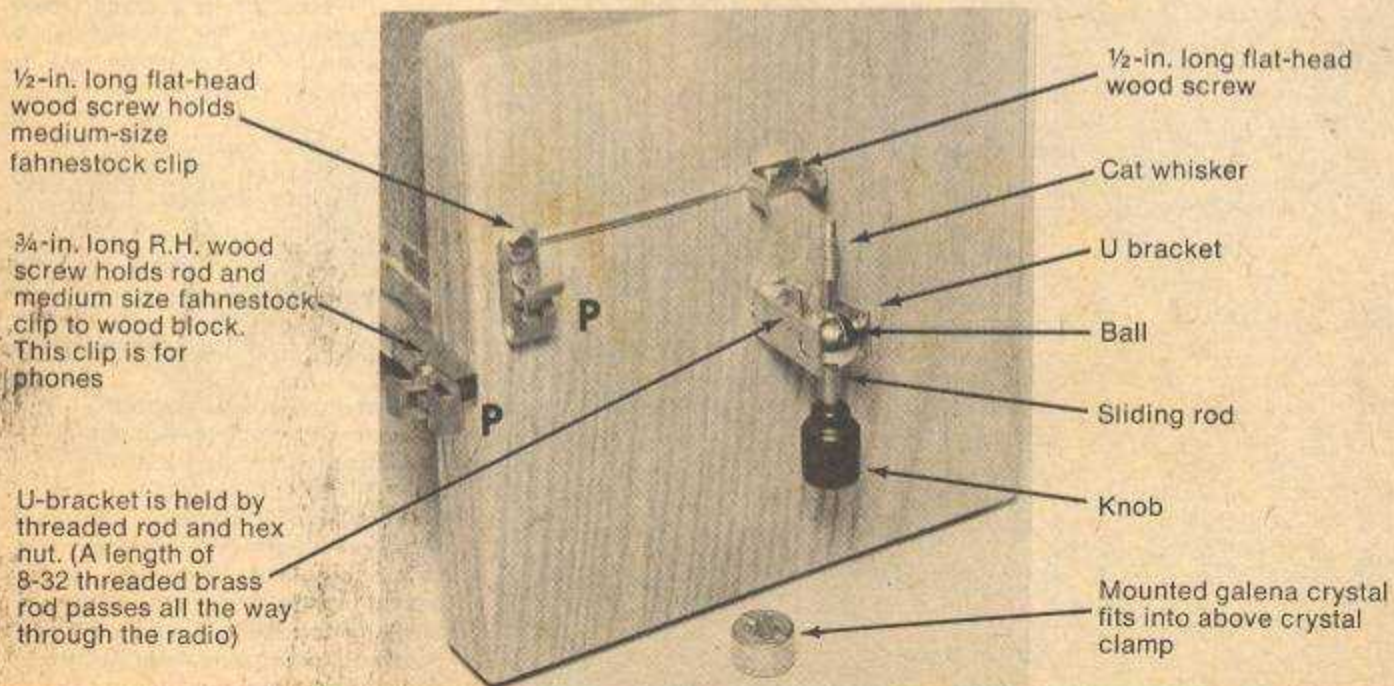



if your "taste" dates to earlier days, try—

# RADIO

by Art Trauffer

of the wire to some object outdoors where there is plenty of room, and unwind a couple hundred feet of wire, and pull the wire tight to stretch out any bends in the wire. Cut off the wire and anchor the end in the two small holes near one end of the tube, and dab a bit of cement to hold it fast. Now wind the coil by turning the tube slowly while you walk towards the tied end of the wire, and when the tube is full of wire cut off the wire and anchor the end in the two holes at the other end of the tube and put on a dab of cement. This trick will give you a neat professional-looking coil.

As shown in the photos, the two wood end blocks for the coil measure 5 x 5 x 3/4-in. and are sanded smooth, stained, and varnished. The writer's first project used oak.

Bore a 3/16-in. hole through the exact center of each wood block; these are for the length of 8-32 threaded brass rod that passes through the coil and holds the wood end blocks. One end of the threaded rod holds the U-bracket of the crystal detector (Fig. 3), and the other end of the rod serves as the antenna binding post (Fig. 2).

Note in Fig. 2 that the end of the coil nearest to the antenna binding post passes through a small hole in the wood block and is clamped between the two washers of the antenna binding post; this automatically connects the coil end to the U-bracket of the crystal detector also.

Figs. 2 & 3 give details for mounting the slide rods, the earphone Fahnestock clips, the ground binding post, and the clamp that holds the galena crystal. The simple hook-up is shown in Fig. 4. Fig. 1 gives all details for making the two sliders that will contact the coil.

**Contact.** Perhaps the hardest job of all is to do a neat job of removing the insulation from the coil when making the two bare wire paths for the sliders. Use fine sandpaper and be careful not to sand off too much of the copper. When you are through brush away any fine copper dust between the turns of the wire. You will get a neater job if you use enamelled wire instead of cotton-covered wire.

For best results with this crystal radio, use a long antenna, a cold water pipe ground, a sensitive galena crystal, and a sensitive high-impedance pair of magnetic earphones.

Your basic materials may be the same, but the bucks required to buy them have certainly bounced upward from bygone days! It cost the editor 49¢ for this box which had four different prices on the top ranging from 49¢ up to 55¢.



Fig. 4 Simple schematic for the crystal radio.

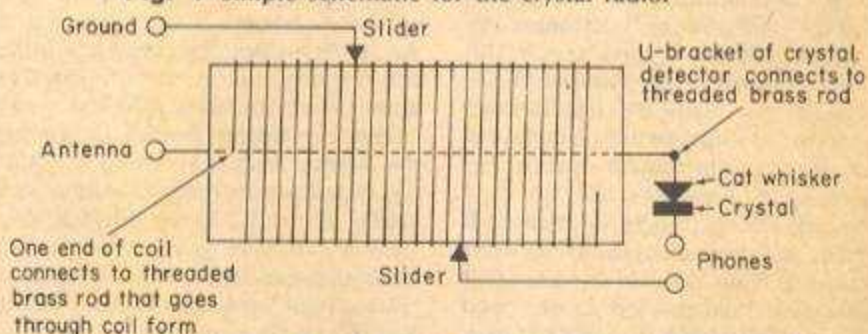

#### BILL OF MATERIALS FOR QUAKER OATS BOX CRYSTAL RADIO

- 1 round Quaker Oats box (18 oz.)
- 1 lb. #20 copper magnet wire, for winding coil (see text)
- 2 pieces 5-in. x 5-in. x 3/4-in. oak, walnut, or mahogany (for coil end blocks)
- 1 foot of 8-32 threaded brass rod (to pass through coil form)
- 1 8-32 brass hex nut (holds crystal detector U-bracket to wood block)
- 2 12-in. lengths 7/32 OD square brass tubing or solid rod (for slider tracks)
- 3 3/4-in.-long round-head wood screws (hold brass rods to wood blocks)
- 1 8-32 x 1 1/2-in. round-head brass machine screw, with hex nut and ornamental thumb nut to fit (for ground binding post)
- 3 inches of square brass tubing to fit snugly over slider rods (for making the two sliders)
- 2 6-32 x 1/4-in. flat-head brass machine screws (to hold knobs to top of sliders)

- 3 inches 1/2-in.-wide brass band (for slider)
- 4 inches of 1/4-in.-wide brass band (for making slider contact blades)
- 2 medium-size fahnestock clips (for phones binding posts)
- 1 1/2-in. long flat-head wood screw (holds one fahnestock clip to wood block)
- 1 unmounted crystal detector stand (K/D Stand 9-14, Modern Radio Labs.)
- 1 mounted galena crystal for above detector stand (9-1 MRL Steel Galena, Modern Radio Labs., P.O. Box 1477, Garden Grove, CA 92642)
- 1 1/2-in. long flat-head wood screw (holds crystal clamp to wood block)

Note: Those who do not have near-by hobby shops or large hardware stores can get most of the above hardware from MRL, P.O. Box 1477, Garden Grove, CA 92642. Send them 25¢ for a copy of their catalog.



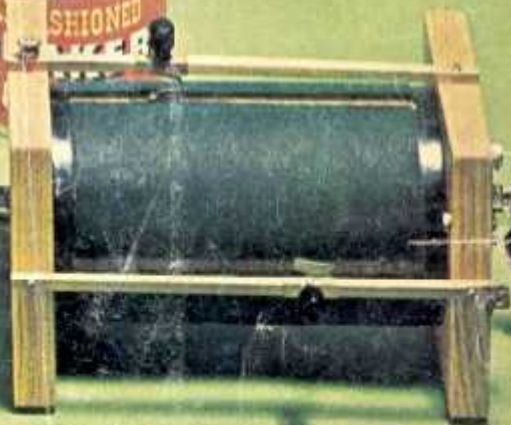





# RADIO

## FOR EVERYBODY



L. J. MARKUS, Editor

## How to Build a Loudspeaker Crystal Receiver



Figs. 1-2. This loudspeaker crystal receiver, front and rear views of which are shown here, will bring in programs day and night on the loudspeaker with amazing clarity and volume if you live reasonably near a radio station. No batteries are needed. Features include a two-gang tuning condenser, new type ultra-sensitive magnetic loudspeaker, beautiful walnut veneer cabinet, indefinitely long life with no operating cost, variable selectivity and sensitivity adjustments, no panel controls, optional fixed crystal and optional head-phone connections. The set is ideal for forest rangers in look-out towers.

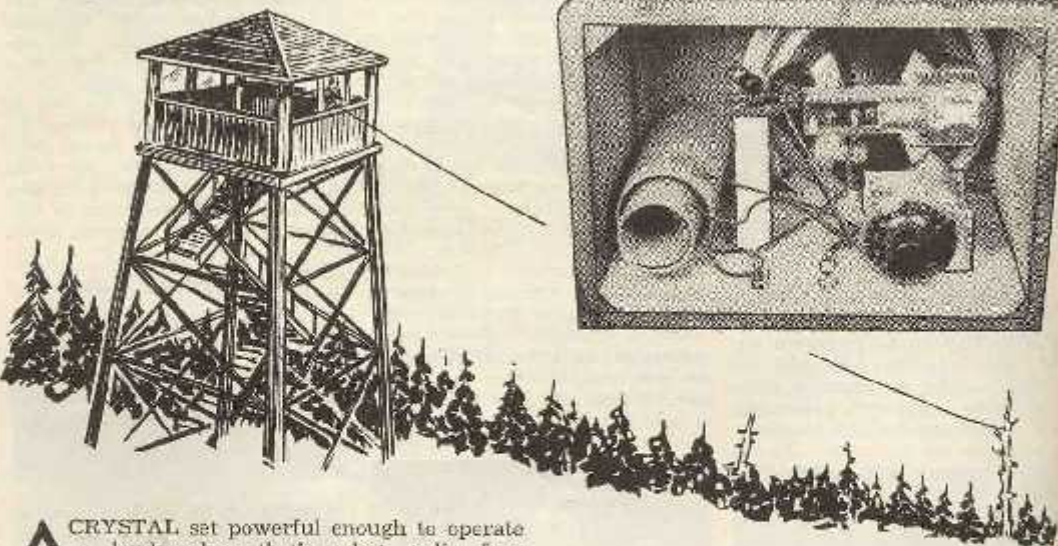
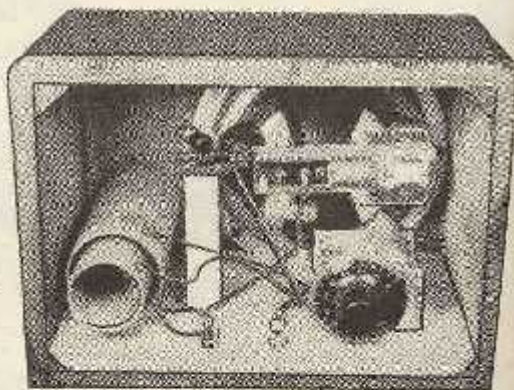

**A** CRYSTAL set powerful enough to operate a loudspeaker—that's what radio fans have been clamoring for since the very first days of wireless. Radio engineers said it couldn't be done, and gave long lists of reasons why the power needed to operate a loudspeaker just couldn't be snatched out of the ether merely by tickling a hunk of shiny rock with a wire cat's-whisker.

This spring we came across a most interesting

paragraph, on this subject, in a letter from SCIENCE AND MECHANICS reader Michael B. Young of Phoenix, Arizona, added as if an after-thought:

*"One of our local stations is being received on a crystal set with a loudspeaker. The station wakes me up each morning at 6 o'clock and is*



loud enough to really enjoy. Am using over 500 feet of aerial and a series of 10 grounds, which I give more credit for the amount of volume than I do the set itself, an ordinary crystal receiver circuit."

This letter definitely indicated that a loud-speaker crystal set could be made. We wrote immediately to Mr. Young for more details, and received by return mail a highly interesting letter telling about his crystal set experiments. Here are excerpts from his second letter:

"I was located about 15 blocks from KTAR, operating on 629 kc. with 1000 watts of power. I used a simple set consisting merely of a single small coil, crystal and cat's-whisker. I added more and more aerial, with better results each time. Both the direction and the length of the aerial seemed to affect volume.

"Next I tried adding grounds. Although the addition of one ground could not be noticed, there was an improvement when I changed from one to five grounds, and another small improvement when I went from five to ten grounds.

"The first loudspeaker I tried was a borrowed 16-inch cone unit. This really worked better than the smaller magnetic loudspeaker I now have.

"I taught Sunday School for a while, and started many of the boys to making crystal sets. None of these worked quite as well as mine, probably because the boys couldn't get up enough aerial. All were able to use loud-speakers, though; if they couldn't, I went out and experimented with the installation until we secured results.

"After the local station went off the air at night, I could get KPO in San Francisco, KFI in Los Angeles and KOA in Denver on the headphones but not on the loudspeaker.

"I generally left the loudspeaker connected all night. Occasionally KTAR would come back on the air about 2 a.m. for tests, waking me up. This station never failed to get me up in the morning when it came on the air for the day.

"Have tried a fixed crystal but so far have not had as good results as with an adjustable unit."

With this encouraging information to start with, an application of radio theory to the problem soon brought forth the fundamental principles involved. Then came experimentation with various circuits, followed by field trials in various locations. From all this was evolved the

highly successful SCIENCE AND MECHANICS loud-speaker crystal set presented for the first time in this article.

Rare indeed is the person who cannot find some use for a radio set which costs only a few dollars initially, yet operates a loudspeaker day and night, year after year, with no batteries or power connections whatsoever and no operating costs.

Place the set on your bedside table and let it lull you to sleep at night. In the morning, it will wake you up again as faithfully as any alarm clock but with none of the ear-splitting clatter to spoil an entrancing dream.

A loudspeaker crystal set is ideal for use in a basement workshop or darkroom. Place it at the back of the bench and listen to favorite programs and to news flashes while pursuing your favorite hobby.

And what could be more perfect than this set for those who must keep lonely vigil in some roadside booth, forest ranger look-out station, gate house or other place fairly near a radio station but not on a power line? The set can be operated continually or turned off at times, as you prefer; either way, there are no battery charging or replacement problems and no worries about the size of next

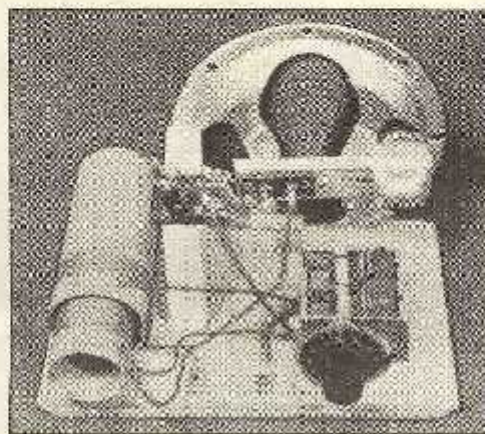

Fig. 3. Rear view of completed loudspeaker crystal set. Note that the crystal detector is mounted on the wood block which supports the loud-speaker. All parts needed will cost only a few dollars. You can wind the coils yourself by following instructions given in this article.

month's electric bill.

This set was designed primarily for those living in the outskirts of cities and on farms fairly near a radio station, for considerable room is required in which to erect the required length of antenna. It is principally a personal radio for use by one person or at most a small group of quiet persons. Obviously, you cannot expect the volume to be comparable to that of a 6-tube electric set feeding 3 watts or more of audio power into a loudspeaker. In our tests, however, the volume was found to be entirely adequate for the average room in a fairly quiet location.

### How It Works

Although this crystal set is considerably more efficient than the single-circuit receiver used by Mr. Young in his experiments, the pictures and diagrams indicate that it is by no means complex. With the pictorial wiring diagram as a guide, any one who knows how to solder should have no trouble whatsoever in building this crystal set.

As the schematic circuit diagram indicates, the set is designed for use with what is known as a



half-wave antenna, with a voltage feed connection to the lead-in. In other words, the lead-in wire is connected to the end of the antenna wire in the usual manner, and the total length of the antenna system from the far end to ground is made equal to one-half the wavelength of the station which is to be received with loudspeaker volume.

With a half-wave antenna, maximum signal voltage exists at the ends, with zero voltage and maximum current at the center. Keep these facts in mind, for they are essential to the success of your installation.

As you can see from the circuit diagram, a parallel resonant circuit is used at the input of this crystal circuit. Having a very high resistance at resonance (when tuned to the frequency of an incoming signal), this resonant circuit matches the high resistance of the antenna. This match insures that the maximum possible amount of signal voltage will be transferred from the antenna to the receiver.

With so little signal loss, practically the entire antenna voltage is developed across resonant circuit L1-C1. The resulting current through primary coil L1 induces a voltage in secondary coil L2. This voltage undergoes resonant step-up in secondary resonant circuit L2-C2, and the output voltage across the circuit is applied to the loudspeaker in series with the crystal detector.

The crystal rectifies the incoming modulated r.f. carrier signal, as it allows current to flow in only one direction. The condenser across the loudspeaker by-passes r.f. pulses to ground, so that only the desired audio signals pass through the loudspeaker and are converted into sound.

The two-gang tuning condenser permits adjusting both tuned circuits simultaneously. Provisions are made for varying the amount of coupling between the coils, as this varies both the selectivity and the sensitivity of the receiver. When two stations interfere, the coils can be moved apart to improve selectivity; when a weak station is desired and there is no interference, the coils can be brought together to give maximum sensitivity.

### Building the Set

First of all, let me emphasize that there are many possible arrangements for the parts in this set, all giving equally good results. You can use the cabinet and mounting arrangement shown here, or can rearrange the parts to fit into a cabinet of your own design, as you prefer. The

important thing to keep in mind, however, is that stray capacities between parallel resonant circuit L1-C1 and ground should be kept at a minimum. In other words, keep this coil well away from any grounded object such as a metal chassis or metal cabinet, and keep its ungrounded lead a half-inch or so away from grounded leads and parts.

A 6" x 9" piece of  $\frac{3}{8}$ " plywood serves as the base on which all parts are mounted. Trim the sides at an angle so they will fit neatly into the cabinet, if you decide to use the attractive walnut veneer cabinet shown in the photos.

Mount the loudspeaker first, cutting a notch for it at the front of the base, and mounting a  $3\frac{1}{2}$ " x  $3\frac{1}{2}$ " x  $\frac{3}{4}$ " block on the base with wood screws for use as a vertical support. Two screws, one into the base and one into this block, will support the loudspeaker rigidly. Because of the rounded top of the cabinet, it will be necessary to cut away a small amount of wood inside the cabinet at the top in order to get the loudspeaker flush against the back of the panel.

Although almost any good magnetic loudspeaker can be used, best results will be obtained with one of the new high-impedance units like that specified on the diagram, having a rated impedance of 10,000 ohms or higher, and having a screw adjustment which controls the position of the armature or moving element. The permanent magnet in this unit

is made from the new high-strength magnet alloy, far superior to that used in older magnetic loudspeakers.

Any desired type of crystal detector can be used. Mount it on the loudspeaker supporting block with a single wood screw.

It is best to use a new two-gang .000365 mfd. tuning condenser with this set, but a unit of the correct size taken from an old radio set should give acceptable results if in good condition. Mount

the unit in back of the loudspeaker, using either wood screws or countersunk bolts inserted from the bottom of the base as required. Any small knob or tuning dial can be placed on the condenser shaft for convenience in tuning. A calibrated dial is not necessary.

Faderstock clips mounted on the base with wood screws will serve nicely as antenna and ground terminals.

### Winding the Coils

Commercial coils are not available for this set, but it is a simple matter to wind your own. Get two 5" long coil forms, one  $2\frac{1}{2}$ " in diameter and the other  $1\frac{1}{2}$ " in diameter. (Specify inside

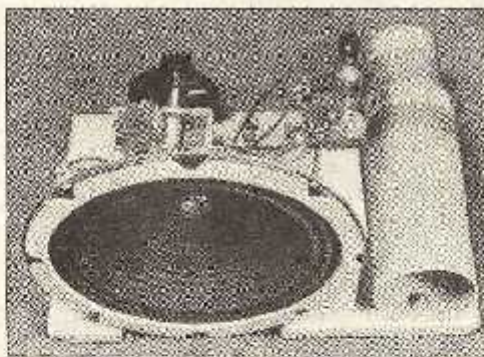

Fig. 4. Front view of completed set. Note the mounting hole for the large coil, and the method of notching the base so the loudspeaker sets into it.



diameters when ordering; these will be 2" and 1½" respectively.) In addition, you will need about 100 feet of No. 32 double silk-covered copper wire, a small piece of beeswax, and a 10-cent roll of 1" wide gummed brown paper (sold at dime stores).

Drill two holes in the large coil form for the mounting bolts, each 5/16" in from an end. Starting 5/8" in from one end, wind on 65 turns of No. 32 wire. Anchor the start of the winding with a small piece of beeswax pressed over the wire, allowing about 8" of wire to project for connections. Anchor the end of the winding with beeswax in the same manner, leaving another 8" for connections.

Wind 130 turns on the smaller form in exactly the same manner, starting the same distance from one end. Now cover both windings with beeswax, using your soldering iron to melt and spread the wax. You'll be surprised at the ease and speed with which you can spread a neat covering of wax over the entire winding, anchoring the turns and making them moisture-proof. Extra wax at each end of a winding, heated only slightly so it will not spread too much, will provide ample anchorage for the fine wire used in the coils.

Although the photos show heavy hook-up wire going to the coils, this is by no means necessary. It was done simply to make the wires show more clearly in the photos.

The method used for providing variable coupling is truly simple. Moisten the end of your strip of gummed paper, then wind it neatly over the unused end of the smaller coil form, until the diameter is exactly equal to the inside diameter of the larger coil form. Cut the paper strip now, and anchor the end by moistening. The smaller form should now slide freely inside the larger, without wobbling. Remove or add gummed paper as required to get a good sliding fit.

### Mounting the Coils

Mount the large coil next. Insert the rear bolt first, after drilling and countersinking a hole for it in the base. Use washers or a dry cell terminal nut to support the coil about ¼" above the base board. Cut or file off the projecting end of the bolt inside the coil after the nut has been tightened, for the small coil must clear the bolt. Insert the small coil from the front, then insert and tighten the front bolt (nearest the loudspeaker). The mounting bolts will prevent the inner coil from being pushed out in either direction, while still permitting ample movement away from the maximum-coupling position (when the centers of the windings coincide).

Connections come next. For convenience, use solid push-back hook-up wire. Solder each connection, using rosin-core solder. Coil leads can be soldered directly to their respective terminals. Use soldering lugs on the Fahnestock clips if they do not already have lugs. Allow enough extra

length in the leads from the small coil so these leads will not break when the coil is pulled all the way out.

An on-off switch is not essential, for the set can be silenced simply by detuning the variable tuning condenser. If you prefer, however, you can insert a s.p.s.t. toggle switch in the crystal detector lead for this purpose.

### Erecting the Antenna

Length, direction and height are all important factors in the erection of a satisfactory antenna

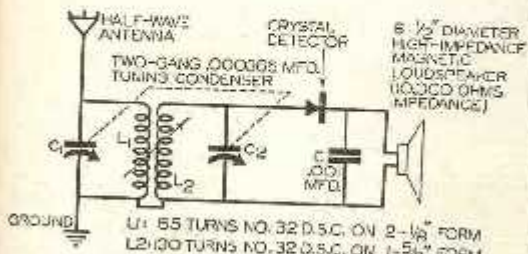

Fig. 5. Circuit diagram of loudspeaker crystal set.

for this loudspeaker crystal set. The length is determined by the frequency of the station which is to be received with loudspeaker volume. To be more specific, the length of the antenna system in feet should be equal to 490,000 divided by the station frequency in kilocycles. This length should be measured from the far end of the antenna to the ground rod along the antenna proper, the lead-in wire and the ground wire.

Extreme accuracy in the length is not essential, for variations of a few per cent either way will have no noticeable effect upon performance. The table in this article gives examples of correct antenna lengths for various station frequencies.

The antenna wire can be of any size and type insofar as performance is concerned. For initial tests, No. 24 enamelled wire is inexpensive and entirely satisfactory, but for a weather-proof permanent installation it is best to use regular antenna wire. Seven-strand No. 23 bare or enamelled wire is standard for antennas, and is ideal for this set. You can also consider solid No. 14 enamelled wire. If you cannot purchase the entire antenna as a single length, be sure to

Station	Frequency	Computation	Ant. Length
KOY	550 kc.	490,000 ÷ 550	891 ft.
WMAL	630 kc.	490,000 ÷ 630	778 ft.
WLW	700 kc.	490,000 ÷ 700	700 ft.
WLS	870 kc.	490,000 ÷ 870	564 ft.
KDKA	980 kc.	490,000 ÷ 980	500 ft.
ESL	1130 kc.	490,000 ÷ 1130	433 ft.
XSTP	1450 kc.	490,000 ÷ 1450	338 ft.
WQPC*	1610 kc.	490,000 ÷ 1610	304 ft.
KDIX*	1712 kc.	490,000 ÷ 1712	286 ft.

\*Police stations. To get one of these or any other police station in the 16-0-1712 kc. police band, use 50 and 130 turns for the large and small coils respectively (instead of 65 and 130 turns).



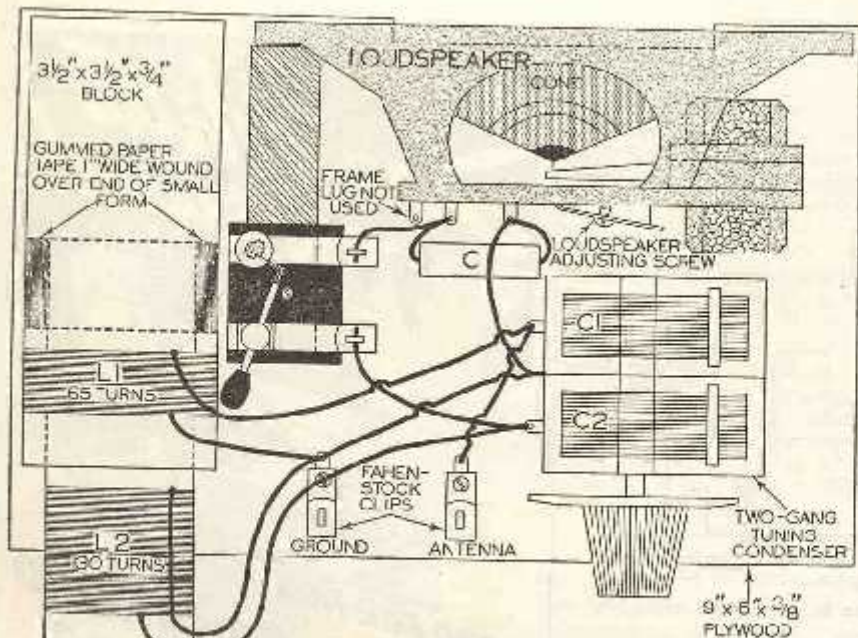

Fig. 6. Pictorial wiring diagram for this loudspeaker crystal set. Connections to either coil can be reversed without affecting the performance.

make strong splices between the pieces, soldering each one carefully. The heavier the wire you use, the farther can be the distance between supports without danger of breakage during high winds or steel storms.

The half-wave inverted-L type antenna for which this set was designed will give best results when broadside to the station (at right angles to a line connecting station and antenna) and poorest results when pointing in the direction of the station. The difference in performance for the two extremes of position is not so great, however, as to warrant neglecting existing high supports which are ideal except for direction.

In our own tests, excellent results were obtained in one instance with the antenna about one mile away from 1000-watt station and pointing directly toward it. This shows that even the poorest antenna direction will work if you are sufficiently near the station.

The end supports for your antenna should be as high as possible, particularly if you are using long spans between supports. Keep the antenna well above objects such as trees and buildings, and at least 20 feet above the ground at its lowest point if at all possible. Since a wire will sag considerably at the center of a long span, an extra support will generally be necessary at the center of a half-wave antenna designed for a broadcast band frequency. For stations below 1000 kc., two or even more extra supports may be needed.

Insulators should be used at all supports, and should be of particularly good quality at the ends, where r.f. voltage is a maximum.

The entire lead-in wire is at high r.f. potential (high with respect to other points in the antenna system; the actual voltage will never be more than a few volts with respect to ground, and hence is perfectly harmless). Stray capacities to ground will lower this voltage, so keep the lead-in at least a foot away from buildings and trees by using long stand-off insulators. You can mount insulators on hardwood strips, projecting outward from a building. Use regular insulated copper lead-in wire such as

solid or stranded No. 16 or No. 18 wire, soldering it carefully to the antenna and using as few insulators as possible. Avoid using a window strip; instead, bring the wire into the house through a porcelain tube or through a hole drilled in a glass window pane.

### Loading Coils

If there is not sufficient room available between supports for the required length of antenna, erect as long an antenna as you can, connect it to the lead-in as usual, then wind the left-over antenna wire on a large form to make a loading coil, and insert this in the lead-in wire near the receiver. This "loads" the antenna, making it in effect a half-wavelength long and giving very nearly the efficiency of the correct longer antenna. The turns of wire on the loading coil should be spaced apart a distance equal to twice the wire diameter. A smaller size of wire can be used for the loading coil than for the antenna if desired, for length rather than diameter is the important factor here. A large cylindrical paper container such as is used for oatmeal makes a good coil form; any paper box about 10" square could also be used. The loading coil should be mounted at least a foot away from all walls and grounded metal objects. A loading coil should not contain more than about one-fourth the total required length, for the greater the proportion of wire in it, the lower will be the efficiency of your antenna system.

Experimentation with a temporary antenna will tell whether a given combination of antenna and loading coil will give sufficient signal pick-



up for a particular antenna direction in your locality.

## Making the Ground

A clean water or gas pipe about 10 feet long, driven almost entirely into the earth in a location where it will contact moist earth continually, makes an ideal ground for this receiver. Use a good ground clamp for connecting the ground wire to the pipe. The ground wire should be of an insulated type, but no special care need be taken in mounting it on the house.

Be sure to use an approved type of lightning arrester. An inexpensive unit employing an air gap is entirely satisfactory. Mount it outside the building at the point where antenna and ground enter the building. Connect one terminal to the ground wire, the other to the lead-in, without cutting either wire.

You can try extra grounds if you like, connecting them all to the same ground wire. In the average fairly moist location, however, the improvement in reception will hardly be enough to warrant the extra trouble and expense if your first ground is properly made.

## Operating the Receiver

It is a good idea to use headphones when first trying out your receiver. Simply connect them across the loudspeaker terminals; this can be done most easily by slipping one phone tip into the Faberstock ground clip, and the other phone tip into that crystal detector clip which goes to the loudspeaker. Slightly greater phone volume will be obtained by disconnecting the loudspeaker; this can be done by removing the loudspeaker lead from the crystal detector temporarily.

To tune in a station after antenna and ground wires have been connected to the proper terminals, adjust the cat's-whisker until it just touches the crystal. With the small coil entirely inside the larger (maximum coupling), rotate the gang tuning condenser slowly. If no station is heard, try different settings for the crystal detector and for the coil. When a station is heard, readjust each control carefully for maximum volume, then disconnect the phones and reconnect the loudspeaker to see if you are getting sufficient loudspeaker volume.

If two stations are heard together when the small coil is all the way in, pull it out a small amount and retune the condenser. Repeat until you hear only the desired station. Separating the coils reduces volume, but at the same time improves the selectivity (station-separating abil-

### WHERE TO GET PARTS

For information as to where you can secure, at unusually low prices, the various parts needed for crystal sets, just drop a letter to Radio Editor, *Science and Mechanics*, 800 North Clark St., Chicago, Ill., asking for a free copy of the data sheet on loudspeaker crystal sets. This contains a complete list of parts needed, along with data on capacitors and fixed crystals. Enclose a stamp for the reply.



ity). Experiment with various coil and condenser settings until you are thoroughly familiar with the operation of your set.

### Front-Panel Controls

Since this crystal set was designed primarily for loudspeaker reception from a single station, no controls were mounted on the front of the cabinet. Once the set has been properly tuned to the chosen station, it will remain in tune indefinitely, so there is really no need for panel controls except possibly for an on-off switch.

If front-panel control is desired in order to change from one station to another conveniently while using headphones, mount the tuning condenser where the coil now is, with its shaft projecting through the panel. Mount the crystal detector above the condenser on a small shelf, with its handle projecting through a one-inch hole drilled in the front panel. Mount the coil crosswise across the back of the base, with a wood dowel rod attached to the sliding coil and projecting out through one side of the cabinet to give push-pull control of the coupling. The loudspeaker can remain where it now is.

### Volume-Increasing Hints

Sharpening the point of the cat's-whisker carefully with a nail file or small metal file will make it easier to find a sensitive spot on your crystal.

Grease or dust on a crystal impairs its sensitivity. Washing the crystal in denatured alcohol will remove any grease left by your fingers when handling the crystal.

After a crystal has been used for some time and has been scratched up considerably, try chipping off a portion of it to expose fresh rough surfaces.

The loudspeaker specified for this set has an adjusting screw. Rotate this slowly a half-turn or so in either direction while the set is in operation, until you find the setting which gives maximum loudspeaker volume.

### DX Reception with Headphones

Excellent distant reception on headphones can be obtained with this crystal set provided the antenna is tuned to resonance for each station. The antenna is naturally resonant (is one-half wavelength long) at only one frequency, but can be tuned to resonance at any other frequency in the broadcast band by inserting either a coil or condenser of the proper size in series with the lead-in wire.

If the antenna is too long for the frequency you wish to receive, insert an ordinary .000365 or .0005 mfd. variable condenser in the lead-in wire and adjust this for maximum volume. If too short, insert an ordinary broadcast band coil (or any other coil you have on hand) in the lead-in along with the variable condenser, and adjust the condenser for maximum volume. A coil and a condenser have opposite types of reactance, so that one cancels out part or all of the other, depending upon their relative sizes. Variable coils

are not easy to make, hence we use the condenser to vary the amount of inductance which is effective in the circuit.

Always readjust the crystal set controls after tuning the antenna, for there will be some interaction between the various adjustments. Keep the antenna tuning units away from grounded objects. If volume is a maximum with the antenna condenser either all the way in or all the way out, try other sizes of coils to see if you can get still better results. This antenna tuning procedure will improve loudspeaker volume if the antenna is shorter or longer than the required length for a station.

If you plan to use headphones frequently, mount two extra Eohentstock clips or tip jacks on the plywood base. Connect one to the ground terminal, the other to the loudspeaker terminal of the crystal detector. A single-pole, double-throw toggle switch can be connected for instant change-over from phones to loudspeaker.

### Limitations of Crystal Sets

If you will be satisfied with headphone reception, you can set up this crystal set practically anywhere and receive at least one station. If you are within 10 miles of a station having a power of 1000 watts or more, and design your antenna specifically for it, you can be sure of good headphone reception of that station.

If you are within a few miles of a station having at least 1000 watts power, you can also expect good loudspeaker volume. The closer you are to a station and the greater its power, the greater will be the volume.

In general, signal strength varies inversely as the square of the distance from a station, at points within its service range. This means that if there is a given signal strength at one point the signal will be only about one-fourth as strong at a point twice as far away.

Loudspeaker reception with a crystal set can be enjoyed only in a relatively quiet room. Any number of persons can gather around the set to enjoy a broadcast provided they remain quiet, but when several begin talking or there are disturbing noises outside, you require more volume (more power) than can possibly be secured with a crystal set.

A fixed crystal will, as a general rule, have slightly less sensitivity than an ordinary crystal detector. Once you get everything properly adjusted and find that you are getting ample volume, try connecting a fixed crystal in place of the crystal detector. It will eliminate the need for resetting the cat's-whisker each time someone bumps the receiver. Some fixed crystals are better than others, so try several if you can.

Adjustable crystals likewise vary in sensitivity, but are sufficiently low in price so you can order several, try them all out, and choose the best.

If you don't expect too much right at the start, and have the patience to make all the experiments and adjustments needed to snatch the very



last micro-volt of signal strength out of the ether, you'll be agreeably surprised with the performance of this little receiver. Remember, however, that you must be at least within ten miles of a high-power station, and preferably within one or two miles, before you can expect good volume.



# Loop Crystal Set

Just aim the loop at the station you want, and then enjoy yourself

By ARTHUR TRAUFFER



watt stations, no conventional antenna or ground is needed. The loop crystal set can be carried around playing, and used anywhere in the house; just aim the loop at the desired station.

Interfering stations, which are at right-angles to the desired station, can be greatly reduced in volume simply by pointing the loop at the desired station with the loop broadside to the interfering station. In some cases, a loop crystal set will prove to be more selective

than most crystal sets using a conventional antenna and ground, but don't expect the same sensitivity with a loop that you will get with a long outside antenna and a cold water pipe ground. A binding post on the side of the cabinet provides for an additional antenna for those living outside the range of the loop, and for those desiring to pick up more distant stations after the locals have signed off for the night.

The extreme simplicity of this set is demon-

**I**N THESE days of powerful transmitters, sensitive germanium diodes, and sensitive earphones, a loop crystal set for local stations is practical and sometimes a distinct advantage. For example, for those living within about 4 miles of 5,000 watt stations, and 5 or 6 miles from 50,000

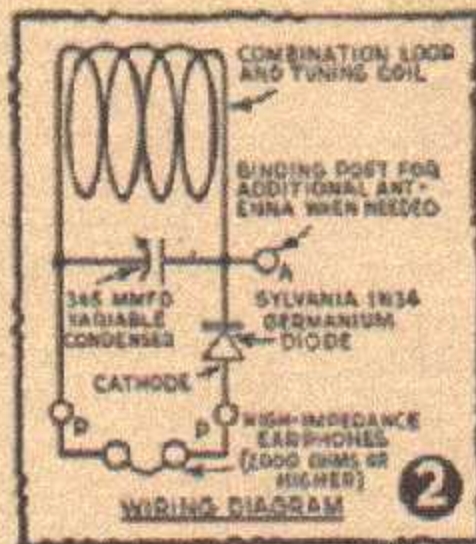

TO RIGHT-HAND PHONE POST AND FRAME OF VARIABLE CONDENSER  
 TO ANTENNA POST, AND STATOR OF VARIABLE CONDENSER

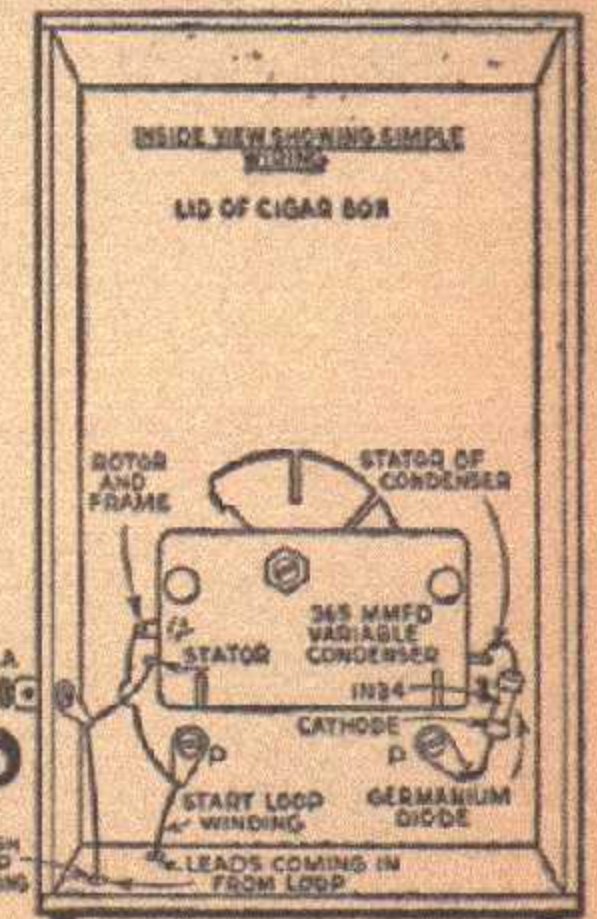
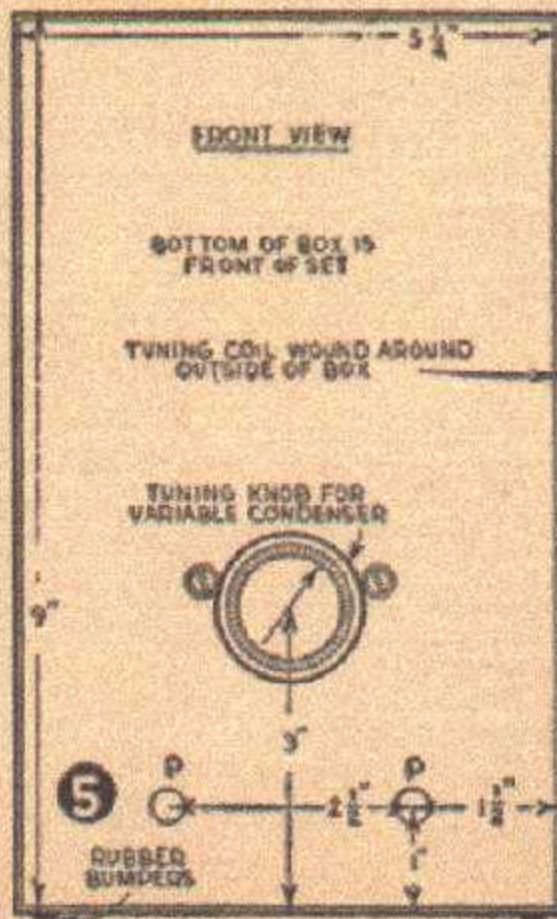
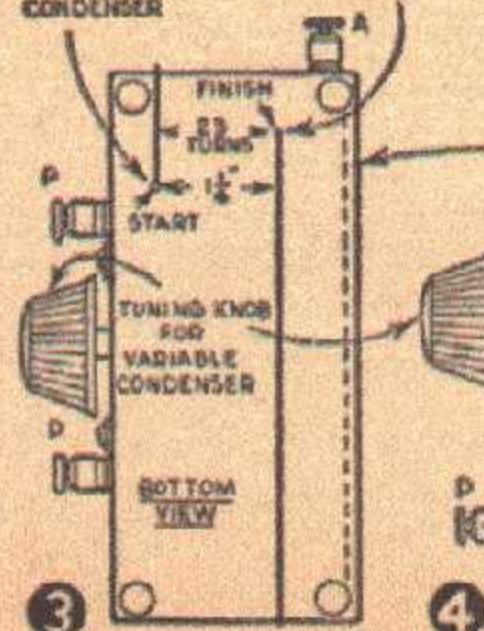



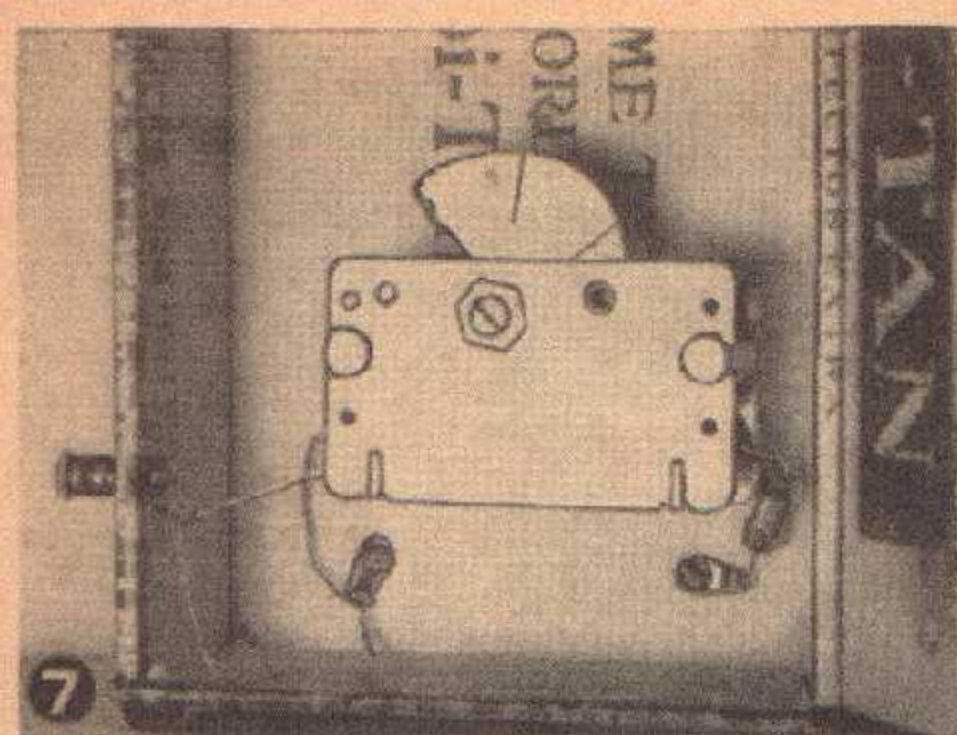

strated by the fact that the set shown (Fig. 1) was assembled and wired by a child under the supervision of the author.

This set differs from other crystal sets in that the tuning coil is wound around the outside of a cigar box to form a loop antenna (Fig. 2), instead of on a small Bakelite or cardboard tube inside the set. Figs. 5 and 6 show the simple layout for the 365 mmfd. variable condenser, the 3 post-type binding posts, or Fahnstock clips for the earphones, and the extra antenna connections. Fasten a soldering lug under the head of each binding post screw. Wind the loop, consisting of 23 turns of #24 gage enameled or double-cotton covered magnet wire, around the outside of the cigar box (Figs. 3 and 4). To start loop winding, connect to right-hand phone post (as seen from front view of set) and to variable condenser rotor and frame (Figs. 3 and 6). Then wind 23 turns clockwise around outside of box and connect the other end of loop

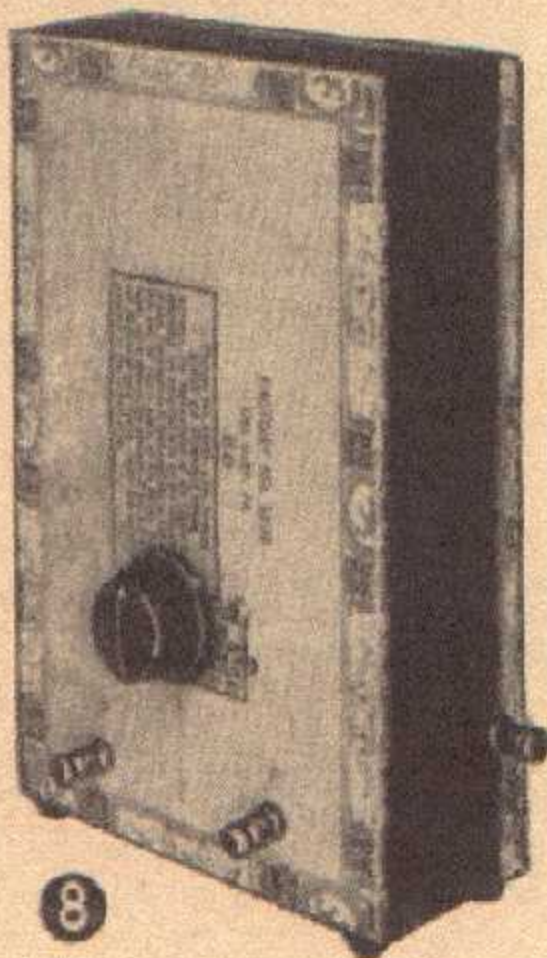

to antenna post and stator of variable condenser. The width of loop winding will be about  $1\frac{1}{4}$  in. with the turns spaced the diameter of the wire apart. Connect germanium diode cartridge from another variable condenser stator lug to left-hand phone binding post (Figs. 6 and 7). Mount a pointer knob or a graduated turning dial, on the variable condenser shaft, and tack or glue 4 small rubber bumpers onto the bottom of the cabinet. The set is now completed (Fig. 1).

Wind a few turns of Scotch tape over the loop wires to protect the wires (Fig. 8), or brush a couple of coats of shellac over the loop wires. The writer tried shunting a small by-pass capacitor across the phone terminals, but no improvement was noted. This loop crystal set will give you slightly more volume indoors than outdoors, due to RF energy picked up by induction from the house wiring circuit. There will be some variation in signal strength in different parts of the room and different rooms in the house, due also to the house wiring circuit.

Glue a disc of heavy white paper or thin white cardboard onto the panel under the pointer knob on the tuning condenser so you can log your stations. When an additional antenna is used, however, the log will shift somewhat due to the added capacity introduced into the tuning circuit by the antenna. A water pipe or gas pipe connected directly to the antenna post makes a very efficient antenna for picking up distant stations. To obtain better results on distant stations connect a water pipe to the antenna post and use a bed spring as a counterpoise. Connect the bed spring to the right-hand phone post, which is the other side of the loop.

If you use a variable condenser larger than the one specified, you may have to remove 1 or 2 turns from the loop in order to cover the entire broadcast band. If you use a smaller capacity condenser you may have to add 1 or 2 turns to the loop. It is best to use a condenser not smaller than 365 mmfd., which is a standard size for the broadcast band. A little experimenting will give the desired results.

#### MATERIALS LIST—LOOP CRYSTAL SET

- 1  $5\frac{1}{2}$ " x 9" x  $2\frac{1}{2}$ " cigar box
- 1 365 mmfd. variable condenser, single gang, any good make. The one used by the writer was made by Insuline
- 1 Sylvania 1N34 germanium diode, or any other sensitive crystal
- 60 ft. No. 24 or 26 enameled or double-cotton-covered magnet wire
- 3 post-type binding posts or Fahnstock clips
- 3 soldering lugs
- 4 small rubber bumpers
- 1 Bakelite knob or tuning dial for  $\frac{1}{4}$ " shaft



# An Inexpensive Crystal Set

## Local Broadcast Stations Can Be Received With Pure Tone Quality

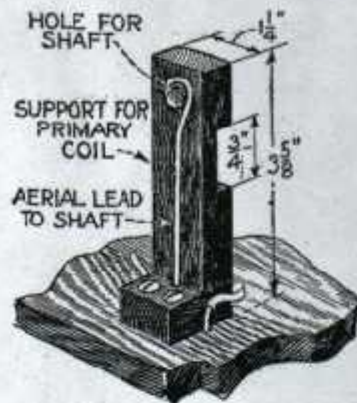

several stations are on the air at the same time, and the average crystal receiver will not tune sharply enough to give satisfaction.

For local stations, a few turns of bell wire around the room behind the molding will answer for the aerial, and a wire clamped to a water pipe makes an ideal ground. The revolving coil makes the set easy to tune. This primary coil is rotated with the finger as indicated in the illustration. It is mounted on the wooden support, de-

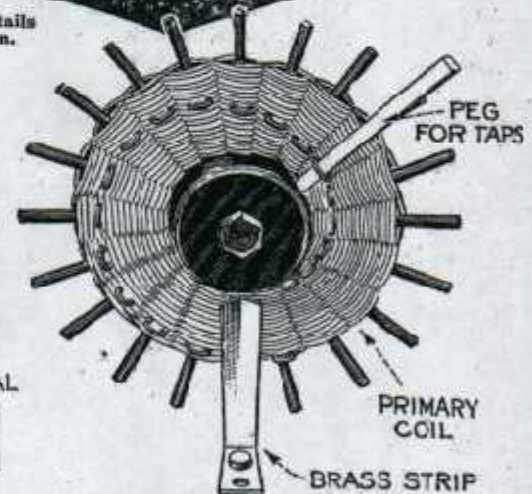
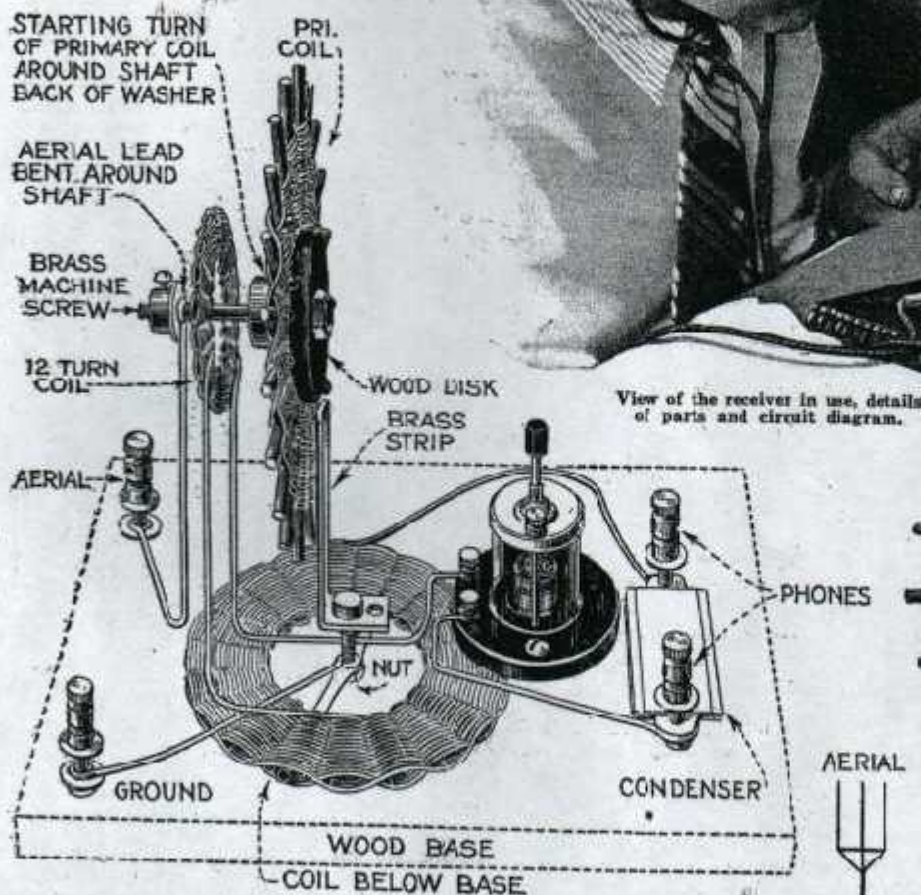

**T**HE crystal receiving set has much to recommend it when the purpose is to receive local broadcasting. This set is easy to construct and simple to operate. It costs little to build, does not require batteries and has a justly deserved reputation for producing clear, undistorted tone quality. The crystal set described below by Will H. Bates which appeared in *Popular Mechanics* magazine, has the additional advantage of being able to separate the "close together" stations, giving the sharp tuning usually obtainable only in vacuum tube sets.

This simple, selective crystal receiver will bring in the broadcast programs within a range of 35 or 40 miles, and can be built for less than \$1, exclusive of the headphones and the aerial and ground supplies. No variable condenser is used, yet the set will separate the local stations. This is of particular advantage in the larger cities, where

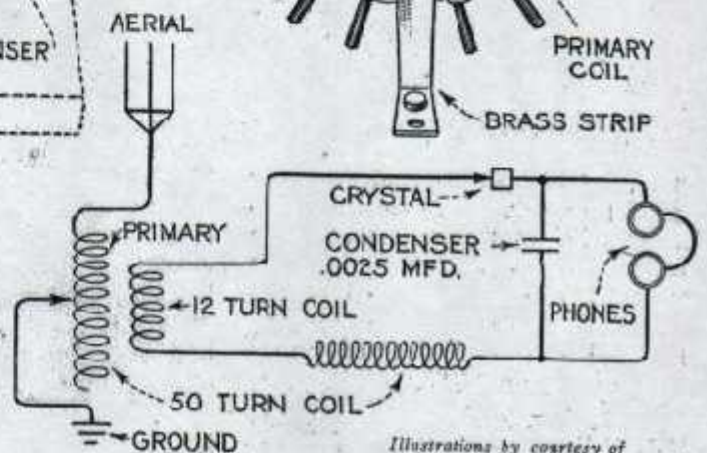

Illustrations by courtesy of *Popular Mechanics*, Chicago, Ill.

tailed in the upper left-hand corner. The shaft is a 1 1/2-in. brass machine screw, and if an old discarded rheostat

(Continued on page 152)



## An Inexpensive Crystal Set

(Continued from page 150)

is available, its shaft, or that of a switch, will serve.

As the coil is turned, the taps are brought in contact with a thin spring-brass strip on the baseboard. The details of the primary coil are clearly shown and the winding is very simple. The form for the coil is the sawed-off end of a large spool,  $1\frac{1}{4}$  in. in diameter. Holes are drilled in the edge for 20 burned-off matches, equally spaced. For the coil No. 22 d.c.c. magnet wire is used. Leave 1 in. or more at the beginning and wind over one spoke, under two spokes, and so on, for two complete turns. At the start of the third run insert a wood wedge to form a flat loop in the wire,

When the turn is completed remove the peg. Every second turn on

the coil will now bring the over-one turn on the adjoining spoke, and the peg is again inserted in the same way, thus advancing the taps in a spiral to the outer edge of the coil and forming 20 in. all. The winding is then continued a part of the way around the coil, clipped and secured around one of the spokes. This end of the wire is not connected in the circuit; the loops are then scraped free of insulation and the spokes withdrawn from the coil. Heavy thread or light string is used to bind the coil, threading it in and out of the openings left by the spokes and tying the ends. The spokes are then re-

(Continued on page 154)

### MATERIAL LIST

- 1 baseboard,  $\frac{1}{4}$  by 7 by 7 in.
- 2 wood strips,  $\frac{1}{4}$  by  $\frac{1}{2}$  by 7 in.
- 2 wood strips,  $\frac{1}{4}$  by  $\frac{1}{2}$  by 6 in.
- 1 wood block,  $\frac{1}{2}$  by  $1\frac{1}{4}$  by  $1\frac{1}{4}$  in.
- 1 piece of wood,  $\frac{1}{2}$  by  $1\frac{1}{4}$  by 3 in.
- 1 crystal detector.
- 1 .0025-mfd. condenser.
- 4 binding posts.
- 1 piece of thin spring brass,  $\frac{3}{8}$  in. wide and  $2\frac{1}{2}$  in. long.
- 1 brass machine screw,  $1\frac{1}{2}$  in. long, with nut to fit.
- 3 small washers.
- 1 small bearing with set screw.
- 1 large spool,  $1\frac{1}{4}$  in. in diameter at ends.
- 1 small spool No. 22 magnet wire.

## An Inexpensive Crystal Set

(Continued from page 152)

placed and the unit is complete and ready for mounting.

The starting wire of this coil is bared and looped around the shaft back of the wood disk, a large nut and washer holding it in place. The aerial wire is brought up through the base and looped around the shaft at the rear of the support, and held in place with a lock bearing and washer. The wooden baseboard is  $\frac{1}{4}$  by 7 by 7 in. and rests on four  $\frac{1}{2}$ -in. strips tacked around the outer edge, so as to allow the larger secondary coil clearance underneath it.

The secondary coil, in two sections, is wound on a form made from the remainder of the spool, the rim of which is drilled to take 19 nails, as shown. The smaller section has 12 turns and is mounted directly back of the primary, and supported by its lead wire but not touching the shaft, spaghetti tubing being used to strengthen the supporting leads. The inside lead of the small coil is taken through the baseboard to the inside turn of the larger coil, and the outside end of the small coil to one side of the crystal detector. Both sections of the secondary are wound with No. 22 d.c.c. wire, the method of winding being over two spokes, and under two. Leave a start and finishing end about 8 in. long, remove from the form and sew together as before. The second section of the secondary has 50 turns, and is made in the same way. It is supported below the baseboard by a thin strip of wood; the author used a paper soda straw. The brass machine screw that supports the spring-brass strip also holds the supporting strip for the large secondary and forms the grounding terminal from the primary through the metal strip. The brass contact strip is bent to form a  $\frac{1}{2}$ -in. mounting piece drilled for the machine screw, and mounted on the baseboard so that it will make good contact with the primary taps when the coil is rotated.

The .0025-mfd. condenser is mounted across the phone posts, under the baseboard. The outside end of the large secondary coil is connected to one phone post, and the other phone post is connected to the other side of the crystal detector, completing the instrument.



# How to Build a Crystal Set

Fig. 1. Front view of the crystal set, showing tuning coil, dial, and the crystal mounting.

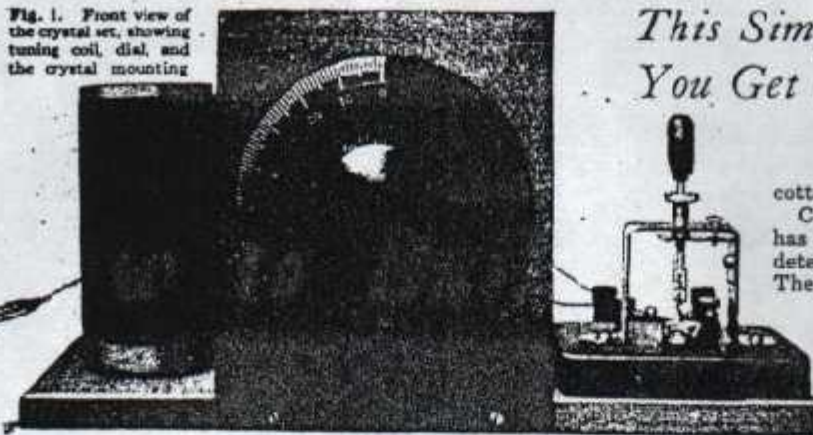

*This Simple Receiver Will Help You Get Started Right in Radio*

By Alfred P. Lane

**T**HERE are many millions of people in this country who live within five miles or less of a powerful radio broadcasting station. And, judging from the total sales of complete radio receivers and the parts from which to make them, a surprisingly large number of these people have not yet taken any interest in radio.

Building a simple crystal radio receiver is a mighty good way to get started in radio. You can build such a set at a minimum of expense and the upkeep cost is practically nothing. Then when you decide later to build a vacuum-tube radio receiver, the whole subject will be much less mysterious and difficult.

A friend of mine started in radio by way of the crystal-receiver route, and while he now possesses a remarkably good five-tube receiver, the old crystal set still is kept in commission and he uses it a great deal. He lives within a mile or two of one of our best broadcasting stations and when he happens to be alone at home and wishes to listen to the program from the local station, he dons the ear phones, adjusts the crystal until he finds a sensitive spot, and settles back in his armchair to enjoy the music while he reads the evening paper.

**A**S HE puts it: "Why should I wear out my tubes and use up my batteries just to hear station WXYZ when the crystal set brings in the music with perfect quality and the ear phones shut out all the street noises?"

The crystal radio receiver shown in Figs. 1 and 4 was designed and built to show how simply and easily a good set of this type can be constructed. No tools were used other than those to be found in every household, such as a small wood saw, a gimlet, a penknife, and a screwdriver. No soldering-iron was used and all the connections were made with the same wire used to wind the tuning coil.

Here are the parts of the set as indicated by letters on the illustrations:

A and B—tuning unit; C—variable condenser, .0005 mfd. (23-plate); D—crystal detector; E—fixed condenser, .0005 mfd.; F—

wooden panel for variable condenser; G—wooden baseboard, 6 by 11 inches; four binding posts, dial for variable condenser, screws, etc.

You will have to buy about a quarter-pound of No. 22 double silk-covered wire for the tuning unit A-B, and of course you also will have to purchase the variable condenser C, the crystal detector D, the fixed condenser E, and the binding posts and dial for the condenser.

It is a mighty good idea to buy a really good variable condenser and dial, because these parts can be used later in a vacuum-tube receiver. Get a dial of standard make so that you will have no difficulty in matching it if the vacuum-tube design calls for more than one dial.

**T**HE rest of the parts can be of low-priced type and of course the baseboard and the panel for the variable condenser can be cut out of an old packing-case or any stray half-inch board that happens to be handy.

The tuning unit A-B is wound on a piece of cardboard tubing two inches in outside diameter and four inches long. There is no magic in this particular size, however. You can use smaller or larger tubing if it happens to be convenient, although you will have to change the number of turns of wire to correspond. The larger the tubing, the fewer the number of turns of wire needed. Cotton-covered wire or enameled wire can be used if you prefer. Use more turns with

cotton-covered and fewer with enameled wire.

Coil A consists of 30 turns of wire and coil B has 85 turns. The number of turns in coil B is determined by the variable condenser you use. The number of turns in coil A, on the other hand, should be adjusted so that you will get the proper degree of sensitiveness and selectivity, and these factors are in turn governed by the distance from the broadcasting station and the size of your antenna.

Two small holes are punched through the cardboard tubing at the point where each coil begins and ends. The coils are wound as close together as convenient. The end of the wire is passed in one hole and out the other, leaving a long end that can be connected directly with the other instruments. The completed coil is held in place by a small brass right-angle bracket in the model receiver, but it is equally satisfactory to glue the end of it to the baseboard. Don't do this until

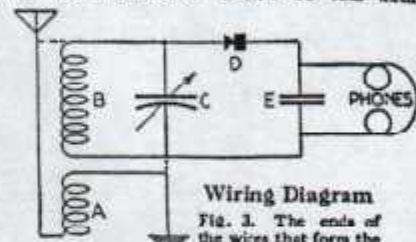

Wiring Diagram

Fig. 3. The ends of the wires that form the tuning unit are connected directly with the binding posts of the other parts. No soldered joints are used.

you are sure that you have the windings right for your particular conditions.

**I**F YOU are very close to several broadcasting stations and you can put up a long outdoor antenna, you may have to cut down the number of turns in coil A. I would suggest that you wind the specified number and then take off turns until you can separate the different broadcasting stations.

Perhaps you are as much as five miles away from the nearest station. In that case you should increase the number of turns in coil A, or you can decrease the number of turns in coil B and connect binding posts Nos. 1 and 2 directly with the ends of coil B, thus eliminating coil A altogether. How to do this is shown in dotted lines in Fig. 2.

The reason for decreasing the number of turns in coil B when coil A is eliminated is because in the latter case the antenna and ground become part of the tuned circuit and their capacity is added to that of the variable condenser C. Eliminating coil A also is desirable if you have to use a

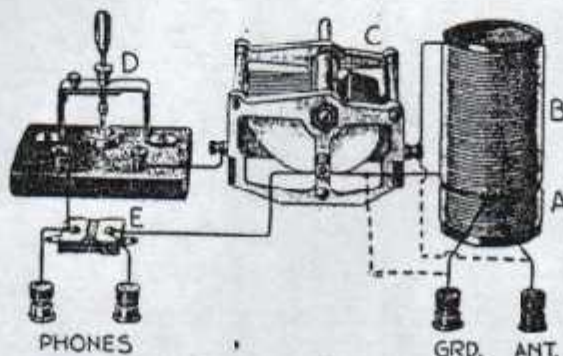

Pictorial Wiring Diagram for Beginners

Fig. 2. Dotted lines indicate connections when very short antenna is used or when broadcasting station is far away.



at  
elp  
radio

wire,  
coil B  
il B is  
u use.  
hand,  
ill get  
and se-  
n turn  
broad-  
your

through  
where  
dials are  
venient,  
ne hole  
ad that  
e other  
is held  
t-angle  
it is  
d of it  
s until



m  
of  
the  
on-  
the  
rts.  
sed

indings  
is.

broad-  
out up  
have to  
coil A.  
nd the  
ff turns  
different

as five  
est sta-  
ould in-  
s in coil  
number  
connect  
directly  
us elim-  
How to  
lines in

sing the  
B when  
cause in  
ins and  
ie tuned  
is added  
ondenser  
also is  
o use

short antenna of, say, 40 feet or less. You cannot expect to get good reception with any crystal set, however, on such a short antenna unless you are within a mile of the broadcasting station.

I AM giving these possible variations so that you can adapt the crystal set to your own particular needs. If you are in doubt about how to do it in your own case, I shall be glad to advise you if you will let me know the actual distance to the nearest broadcasting station and the length and height of antenna you can put up.

After the coil A-B is wound, study Figs. 1 and 4 and mount the rest of the instruments as shown.

The wiring is extremely simple. The wire from the upper end of coil A goes to binding post No. 2 and the other wire from coil A goes to binding post No. 1. Then scrape off the insulation on the wire from the lower end of coil B so that you can connect it with the binding post that is on the metal framework of the variable condenser C. This wire continues to one side of the fixed condenser E and then to binding post No. 3.

Now connect the top end of coil B with the binding post on condenser C, which is fastened to the stationary plates of the condenser. Many types of variable condensers have a binding post at each end of the stationary plates. If yours is of this type, connect the other binding post on the stationary plates with one terminal of the crystal-detector stand.

COMPLETE the wiring by connecting a wire from the other terminal of the crystal detector stand with the remaining terminal of fixed condenser E and continue it to binding post No. 4.

The antenna should be as long and as high as you can get it and should be insulated at every point where it touches any support. Connect it with binding post No. 1. Then connect binding post No. 2 with the nearest cold-water pipe.

The head phones should be connected with binding posts Nos. 3 and 4. Buy good head phones. The quality of your reception depends on them and they always will be useful, even with a vacuum-tube set, for tuning in distant stations and for listening in late at night when you do not want to disturb the neighbors by running the loudspeaker.

Most head phones are adjusted so that they will clamp tightly on the smallest size of head.

## \$225 in PRIZES

### Remarkable Contest for Radio-Set Builders

WATCH for the December number of POPULAR SCIENCE MONTHLY. It will give you all the rules for a new and decidedly unique radio competition.

It will show you how you can build yourself a fine radio receiver and at the same time compete for a first prize of \$150, a second prize of \$50, and a third prize of \$25.

You need not be a radio expert to stand a chance of winning one of these prizes. And even if you do not win a prize, you are sure to have a highly efficient radio receiver as compensation for your trouble.

This contest will give you a chance to exercise your mechanical ingenuity, your skill as a home craftsman, and actually to do intensely interesting and practical experimental work in developing an excellent radio receiver.

### Don't miss this unusual contest IN NEXT MONTH'S ISSUE

You will find much more comfort in wearing them if you will bend the frames very carefully until they will just stay in place on your ears. Additional comfort may be secured by bending the headbands so that they touch your head evenly for several inches instead of just at one or two spots.

To get the set into operation after everything is connected properly, check up the radio program in your daily paper and make sure that the station you want to hear actually is broadcasting. Place the head phones on your head and with one hand turn the dial of condenser C back

and forth very slowly, while with the other hand lightly touch the fine wire, called the "catwhisker," to the surface of the crystal at various points. Eventually you will find a sensitive spot and you will hear music or speech in the head phones.

When you finally locate a really sensitive crystal, it should be treated carefully. Protect it from dust and do not handle it with your bare hands. Use pliers to pick it up or use a piece of dry cloth over your fingers.

Since this crystal radio receiver will be your first introduction to radio at first hand, you probably will be a bit curious as to how the radio signals that come down the antenna are converted into sound waves that you actually can hear.

To begin with, the radio waves are oscillating back and forth at enormously high frequencies. At a wave length of 200 meters they are sliding up and down your antenna and through the A coil of your receiver at a rate of 1,500,000 times a second. This current, moving back and forth through the wire in the A coil, sets up a rapidly changing magnetic field about the coil and the changing lines of force cut through the turns of wire in the B coil and induce a current in them. This current in turn flows back and forth through the wires of coil B to the plates of variable condenser C. Turning the dial

(Continued on page 146)

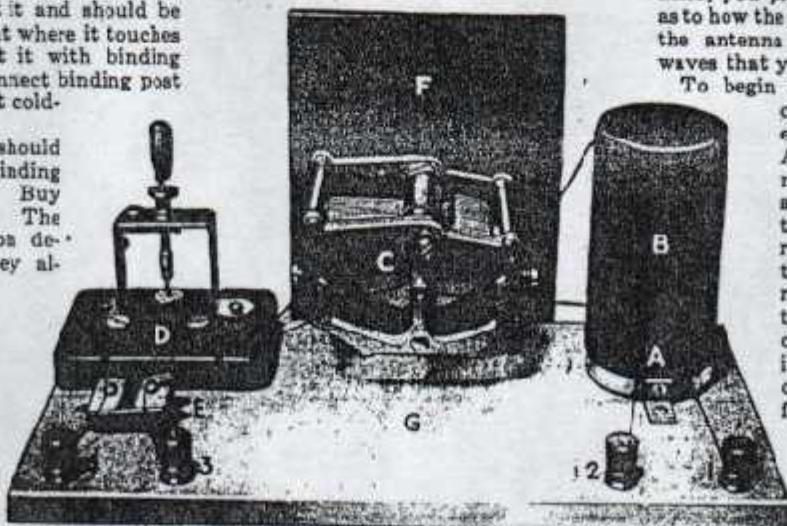

How to Assemble the Parts on Baseboard

Fig. 4. This view shows how to assemble the instruments on the baseboard and wooden panel. Note that the connections from binding posts to the fixed condenser E are made by means of 6-32 brass screws passed through the holes in each system as illustrated.



## A Simple Crystal Set

(Continued from page 59)

of condenser *C* alters the electrical capacity of the condenser and when the signal becomes loud, it is because the capacity of the condenser has been so adjusted that the combination of coil *B* and condenser *C* has been tuned so that the current flowing back and forth can keep time with the changes in the current in coil *A*.

Naturally you cannot hear vibrations in the air that are changing as rapidly as 1,500,000 times a second. In fact, the highest note the human ear can hear has about 30,000 vibrations a second.

The voice or music going into the microphone at the broadcasting station has the effect of chopping the radio wave into sections and the sections are in time with the music. This is where the crystal detector comes in. Its function is to block off half of each radio wave so that the whole group of rapidly changing waves that form one vibration of the music will act together to pull the diaphragm of the head phone in one direction. Then the next group of radio waves comes along and gives it another pull, so that it moves back and forth in time with the music and you can hear it.

The reason that a crystal radio receiver will bring in music only from short distances is because the sound in the head phones when you use a crystal set actually is produced by the energy of the radio waves themselves. In a vacuum-tube receiver, on the other hand, the radio waves simply are used as triggers to release relatively far more powerful bursts of energy from your batteries. And this explains why reception with a crystal receiver is so true to life. There is no chance for distortion to creep in, due to faulty vacuum tubes or batteries.

## What Our Readers Say

### Downright Enjoyment

I believe that for downright enjoyment to a man of mechanical inclination there is no better magazine published. Certainly I enjoy nothing more than keeping abreast the world of science and invention, made possible by POPULAR SCIENCE MONTHLY.—A. K. M., Bowden, Alta., Can.

### From a Home Worker

I have made a good many things that I have learned how to build from POPULAR SCIENCE MONTHLY. I have made foot-stools with springs, hatracks, kitchen tables, workshop bench, writing-desk, chest, tool cabinet, trellises for the house, just in my spare time, and I am very interested in your magazine.—J. J. B., Binghamton, N. Y.

### Mines of Information

I always have taken the greatest interest in the Home Workshop and Ship-shape Home sections and for a long time have been cutting out the "tidbits" of special interest and putting them in scrap albums. Consequently my albums are regular mines of information, and the envy of my mechanically minded friends.—E. B. R., Regina, Sask., Can.



**H**ERE'S a pint-sized crystal radio with enough comph to drive a  $2\frac{1}{2}$ " speaker. This little unit's selectivity is far better than you'd expect to find in a crystal receiver and volume is equal to that obtained with sets using a transistor. No external power source is required.

The unusual selectivity of this radio is due to its special double-tuned circuit. A pair of diodes connected as a voltage-doubler provides the extra kick to operate the small speaker. An output jack is provided for headphone listening and for connecting the set to an amplifier.

**Construction.** The model was built on a  $2\frac{1}{2}$ " x  $4\frac{1}{2}$ " wooden chassis with a  $3\frac{1}{2}$ " x  $4\frac{1}{2}$ " metal front panel. However, size is not critical, and other materials can be substituted if desired.

Two standard ferrite loopsticks,  $L_2$  and  $L_3$ , are used. Both must be modified by the addition of a second winding,  $L_1$  and  $L_4$ , respectively. Each of the added windings consists of 22 turns of No. 24 cotton-covered wire wound on a small cardboard tube as shown on the pictorial. (Actually, any wire size from No. 22 to No. 28 with cotton or enamel insulation will do the job.) The

# High-Power Crystal Set

*Voltage-doubler circuit drives miniature speaker.*

By WALTER B. FORD

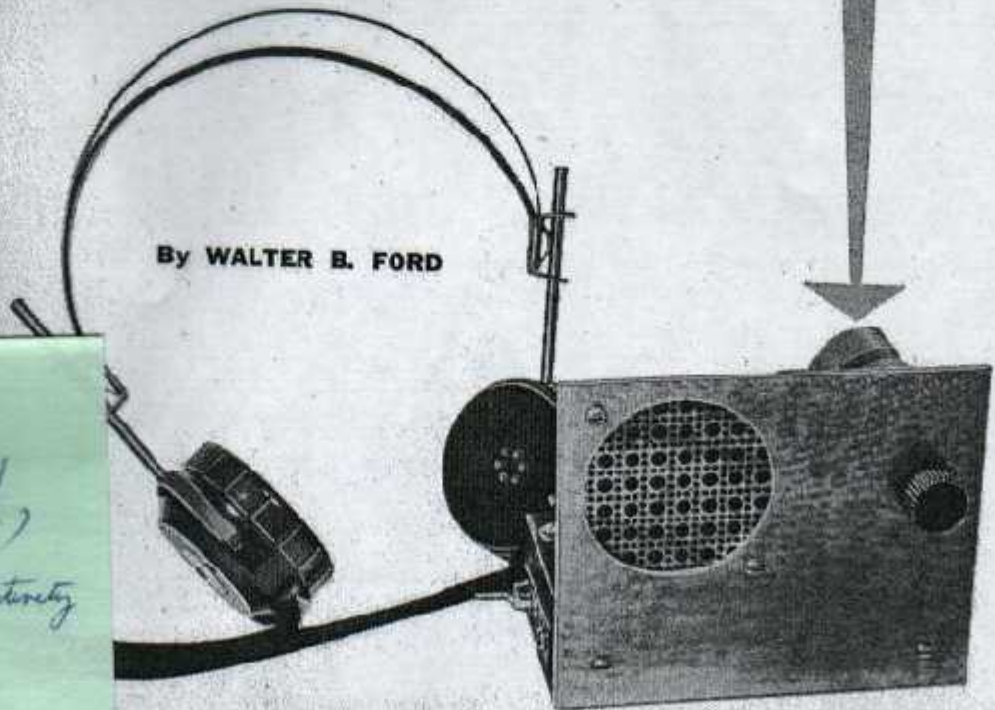

ELECTRONIC EXPERIMENTER'S HANDBOOK

one of the best designs around, full wave, good selectivity, good sensitivity





Layout is not critical but L2 and L3 should be mounted at right angles to each other.

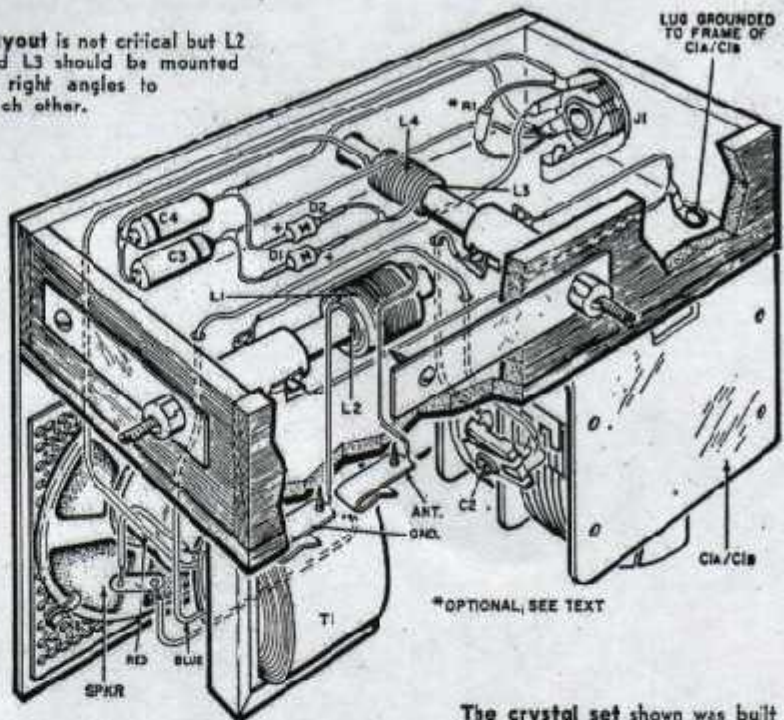

The crystal set shown was built on a wooden chassis. If a metal chassis is used, be sure to insulate the Fahnestock clips (antenna and ground) from the chassis.

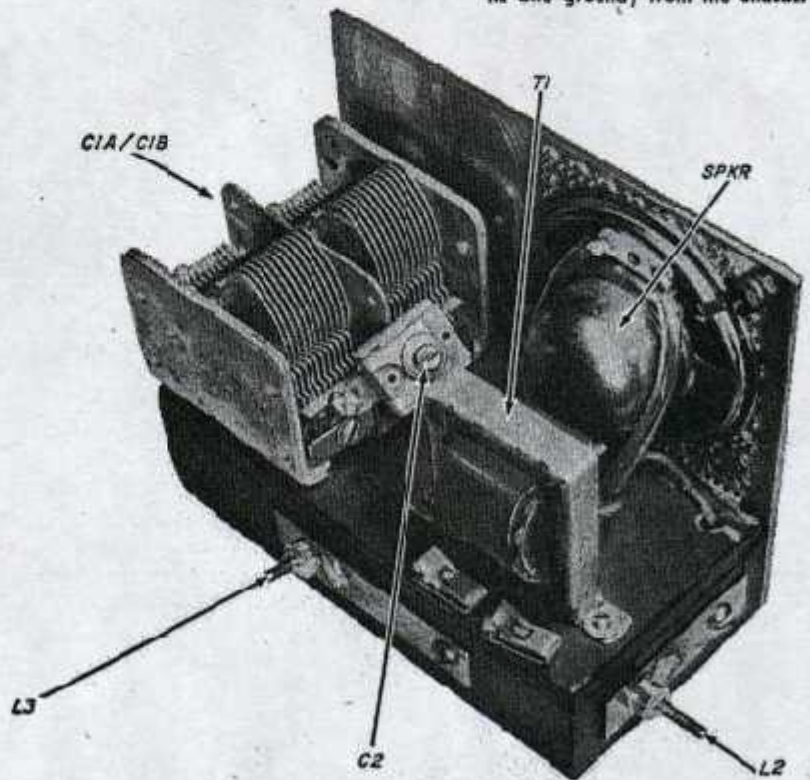



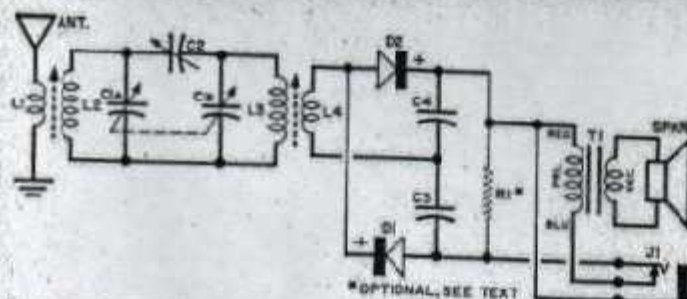

For phone operation only, the speaker, transformer, and resistor  $R_1$  can be omitted. In this case, connect high-impedance phones in place of  $R_1$ .

diameter of the cardboard tube should be slightly larger than  $L_2$  and  $L_3$  so that  $L_1$  and  $L_4$  will slip over  $L_2$  and  $L_3$  easily.

Resistor  $R_1$  is used only for feeding the set into an amplifier; it should be omitted for both earphone and loudspeaker operation. Trimmer capacitor  $C_2$  should be soldered across the stator terminals of two-gang variable capacitor  $C_{1a}/C_{1b}$ , as shown. The speaker and output transformer can be mounted wherever convenient.

After all of the parts have been mounted on the chassis, wire them together following the schematic and pictorial diagrams. Be sure that diodes  $D_1$  and  $D_2$  and capacitors  $C_3$  and  $C_4$  are correctly polarized.

**Alignment and Operation.** To align the receiver, first connect it to an antenna and ground. (The optimum length of the antenna varies with location, but 50 feet will usually be suitable in areas serviced by several broadcast stations.) Next, plug in a high-impedance earphone at jack  $J_1$ . Tune in a station near the high-frequency end of the broadcast band—say 1500 kc.—and adjust the trimmer capacitors on variable capacitor  $C_{1a}/C_{1b}$  for the loudest signal.

Trimmer capacitor  $C_2$  should then be adjusted for the best selectivity and volume over the entire broadcast band. Finally, coils  $L_1$  and  $L_4$  can be optimally positioned by sliding them back and forth over coils  $L_2$  and  $L_3$ . If a nearby station interferes with reception of a weaker one, tune the slug on  $L_2$  for minimum interference.

For loudspeaker operation, simply unplug the earphone from  $J_1$ —strong local stations should come in with fair volume. To operate the set as an AM tuner, wire  $R_1$  in place and connect  $J_1$  to the crystal-phono input of a preamplifier or integrated amplifier. The set should give excellent results with a quality hi-fi system.

—30—

## PARTS LIST

- $C_{1a}/C_{1b}$ —2-gang, 365- $\mu$ f. variable capacitor (Lafayette MS-142 or equivalent)
- $C_2$ —180- $\mu$ f. compression-type trimmer capacitor
- $C_3, C_4$ —0.05- $\mu$ f. fixed capacitor
- $D_1, D_2$ —1N34A diode
- $J_1$ —Closed-circuit phone jack
- $L_1, L_4$ —22 turns of No. 24 cotton-covered wire (see text)
- $L_2, L_3$ —Ferrite antenna coil (Miller 6300 or equivalent)
- $R_1$ —67,000-ohm, 1/2-watt resistor (see text)
- $T_1$ —Replacement-type output transformer; 3000- to 10,000-ohm primary; 4-ohm secondary
- Spkr.—2 1/4" speaker; 4-ohm voice coil
- Misc.—Hardware, wood, aluminum sheet, Fahnestock clips, etc.



## HOW IT WORKS

The receiver employs a double-tuned circuit feeding a crystal-diode voltage-doubler/detector which drives a small speaker. In operation, r.f. signals picked up by the antenna system are induced into coil  $L_1$  from coil  $L_2$ . The desired signal is selected by tuned circuit  $C_{1a}-L_2$  and coupled through capacitor  $C_2$  to a second tuned circuit,  $C_{1b}-L_3$ , which improves the selectivity by narrowing the r.f. bandpass. The twice-tuned r.f. signal is then induced into coil  $L_4$  from coil  $L_3$ .

The positive half of the r.f. signal appearing across  $L_4$  passes through diode  $D_2$  to charge capacitor  $C_4$ ; the negative half of the signal passes through diode  $D_1$  to charge capacitor  $C_3$ . Polarities of the charges on  $C_3$  and  $C_4$  are such that the effective voltage is doubled. This voltage appears across the primary of output transformer  $T_1$ , which changes the high impedance at the output of diodes  $D_1$  and  $D_2$  to the low impedance required by the speaker.

When high-impedance earphones are plugged into closed-circuit jack  $J_1$ , the speaker is disconnected and the output from the diodes feeds directly into the earphones. Optional load resistor  $R_1$  is placed across the output of the diodes when the receiver is used with an amplifier.



# GRANDPA'S WHISKER

Build a carborundum detector from the days of the not-so-ancient mariners

by Charles Green

IN THE BEGINNING OF this century, when radio was still called "wireless," the crystal set was used by most of the early radio pioneers. The simple "catwhisker" touching a piece of galena or silicon crystal, and a coil wound on an oatmeal box, formed a primitive yet effective radio receiver that stayed popular for many years. Even the later development of the vacuum tube could not entirely bury the crystal set; it still remained popular as a first set for many radio experimenters who later went on to more complicated electronic developments. Even today, the simple crystal set is still being built using modern germanium or silicon diodes in place of the moveable catwhisker and crystal.

Back in the old days, the popular galena and silicon crystals had a rival for the more specialized ship-to-shore communication work. It was the carborundum crystal detector. The carborundum

crystal detector did not require a light touch with the catwhisker, but instead required a heavy contact pressure. This heavy catwhisker pressure was more suitable for the early radio stations on ships. The lesser sensitivity of the carborundum detector was compensated by the crystal's ability to take stronger radio signal energy (such as leakage from nearby spark transmitters) without burning out, then the galena and silicon crystals could. What is really different about the carborundum detector, is the requirement for a bias battery. This bias battery is normally not used with galena and silicon crystals.

You can experiment with the carborundum detector by building our *Grandpa's Whisker*, which is patterned after the early crystal sets. The receiver uses a tapped coil and two variable capacitors (one capacitor tunes the antenna) to allow coverage of the entire

broadcast band and for maximum signal coupling to the detector. A separate assembly is provided for the carborundum detector and a control is mounted for convenient adjustment of bias battery voltage for maximum detector sensitivity. The receiver is built "breadboard style" on a 8½-inch by 7¼-inch by ¾-inch wood base which is similar to the style of construction used by early radio experimenters.

**The Receiver Circuit.** Signals from the antenna are fed through J1 and coupled through C1A-C1B to the parallel tuned circuit of L1-C2. C1A-C1B is in a series tuned circuit with L1, and serves to tune the antenna for maximum RF current flow. The resultant tuned signals are detected by D1 and the audio is fed through the R1 bypass C3 to J5-J6 and external headphones. R1 adjusts the D1 bias voltage from B1 and C4 is the RF bypass for the headphones.

**Carborundum.** Not a natural mineral like galena or silicon, carborundum is the name given to a compound of silicon carbide by its American inventor, Edward Goodrich Acheson (a former assistant of Thomas Edison). Acheson was experimenting with a primitive electric furnace in 1891, when he fused a mixture of clay and powdered carbon. He found that the resultant crystals would cut glass similarly to a diamond (silicon carbide is next to a diamond in hardness), and he called his discovery Carborundum, thinking it was a substance composed of carbon and corundum (a crystallized form of alumina). Scientific analysis later showed it to be silicon carbide, but the designation Carborundum was kept as a trade name. Industrial usage of carborundum is primarily grinding compounds and grinding wheels.

Its use as a detector was discovered by experimenters around the beginning

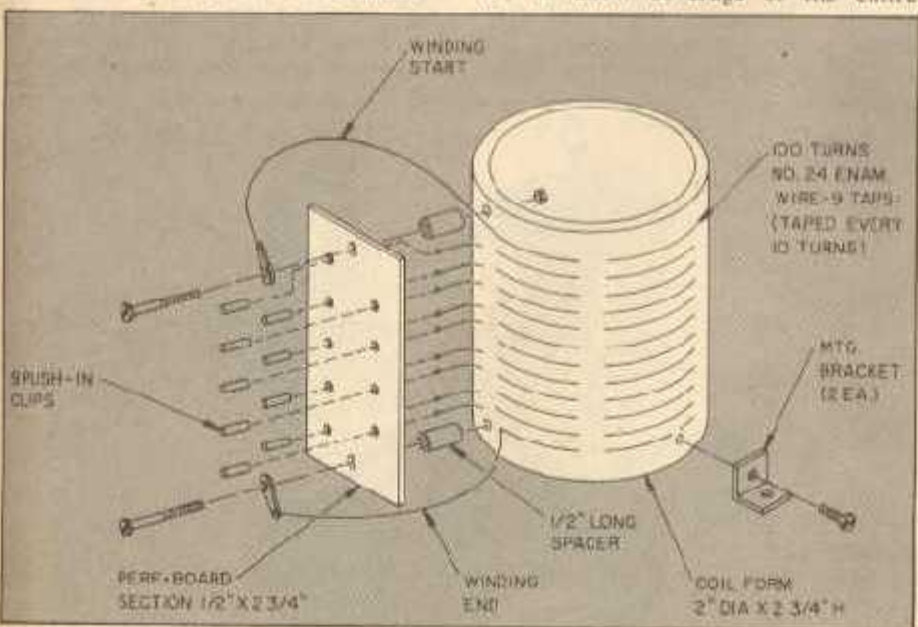
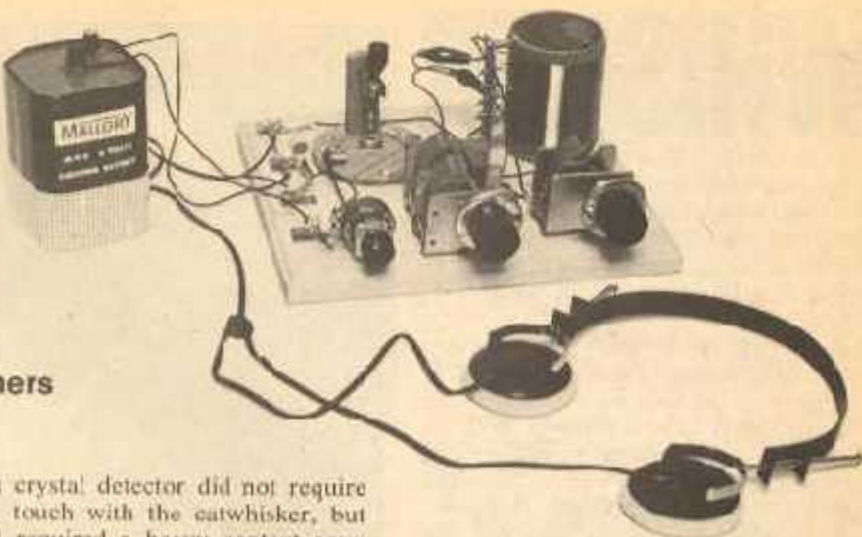

The tuning coil is wound on a cardboard mailing tube section for 100 turns of #24 enameled wire, tapped every ten turns. The taps should be stripped bare with sandpaper before soldering to the clips which are mounted on a section of perfboard. See the text.



# WHISKER

of this century who tried various minerals and substances in their search for better types of radio wave detectors; much as Edison tested many materials in his search for the proper material for his incandescent lamp filament.

A crystal diode has a high current flow with voltage applied so that it conducts in the forward direction (cat-whisker to crystal), and a very low current flow in the reverse direction. The amount of current flow in the forward direction depends upon the characteristics of the crystal material and the applied forward voltage. As shown in the Crystal Forward Conduction Curves graph, Germanium minimum voltage is approximately 0.3 V, Silicon is 0.6 V, and Carborundum is 3 V. (The high Carborundum voltage is the reason why a bias battery is necessary to move the firethreshold down so that the weak RF signal voltages can be detected.)

**Tuning Coil (L1) Construction.** Look at the drawing of the L1 construction details. The tuning coil is wound on a cardboard mailing tube section 2-inches in diameter and 2 3/4-inches long. Start winding approximately 1/4-inch from the form edge with #24 enameled copper wire. Punch a small hole to feed the wire into the cardboard before you start winding, then wrap the wire around the edge of the form to hold it in place while winding; or, a section of plastic tape can be used to keep the wire from moving.

As shown in the drawing, the tuning

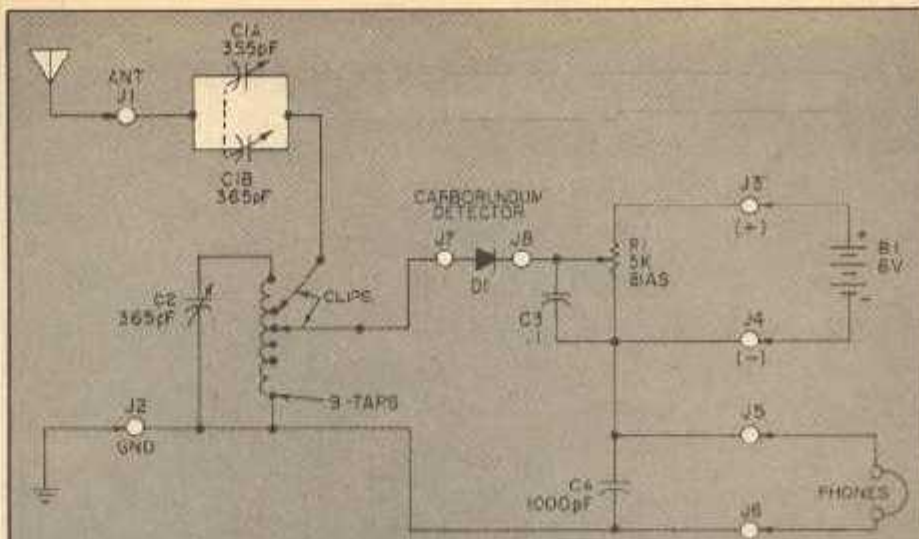

## PARTS LIST FOR GRANDPA'S WHISKER

- B1—6 V battery
- C1A-C1B—Dual 365-pF tuning capacitor (dual gang)
- C2—365-pF tuning capacitor (single gang)
- C3—0.1- $\mu$ F capacitor
- C4—1000-pF capacitor
- D1—Carborundum Crystal (Modern Radio Labs, P.O. Box 1477, Garden Grove, CA 92642), and Crystal Detector Assembly (Philmore #7003 open type detector, or equiv.)
- J7-J8—Fahnestock Clips

- L1—See drawing and text
- R1—5,000-ohm potentiometer, (linear taper)
- MISC: 2000-ohm earphones, 2 1/4-in. x 2-in. dia. coil form, clips, #24 enam. wire, 1/2-in. long spacers, perfboard strip, push-in clips, solder lugs, mtg. brackets, wood sections for detector assembly, knobs, 8 1/2-in. x 7 1/4-in. x 3/4-in. wood base, hook-up wire, wood screws, headphones (2000-ohms), and a 1N34A germanium diode for equiv. for initial adjustment of the receiver.

coil is wound with 100 turns and is tapped every 10 turns. An easy way to make the taps is to twist the wire together for a half-inch and position the free end out. Then, when all of the taps have been made, used sandpaper to take the enamel off the tap-wire ends. At the end of the winding, punch another hole in the coil form and after cutting a three inch lead, thread the free end of the coil wire through the

hole and wrap it one turn around the coil form edge (or tape it in place).

Mount 9 push-in clips in a 1/2-inch by 2 1/4-inch perf board section and mount it on the coil form with machine screws and nuts and two 1/2-inch long spacers (as shown in the drawing). Then solder the coil taps to the push-in clips. Connect the coil start and end wire leads to solder lugs mounted on the perf-board screws. Punch two holes



Most of the crystal detector assemblies you can turn up will be of the horizontal type. You will need a heavier pressure for the carborundum crystal, so convert the assembly to a vertical format. None of the dimensions shown are all that critical.

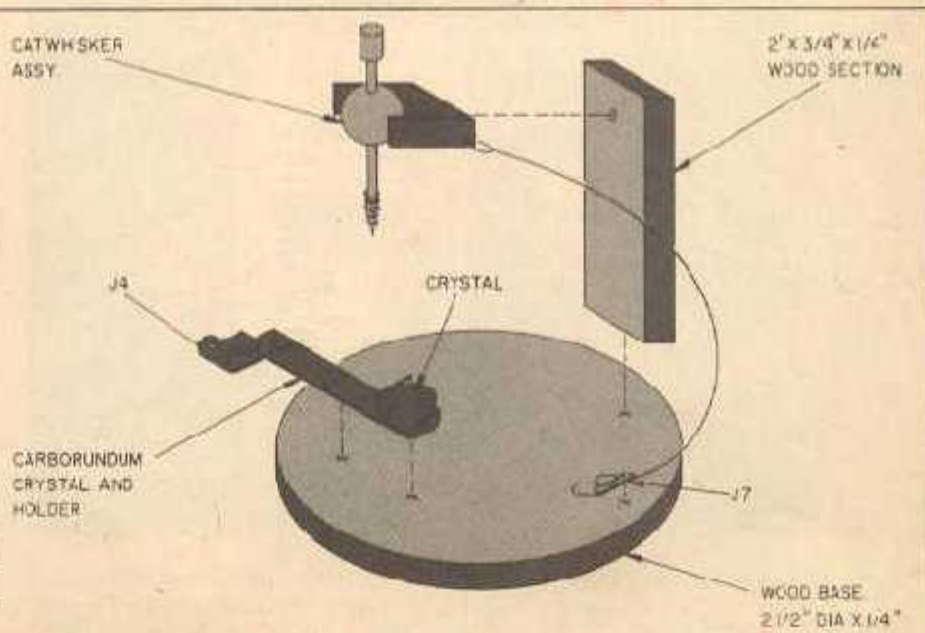



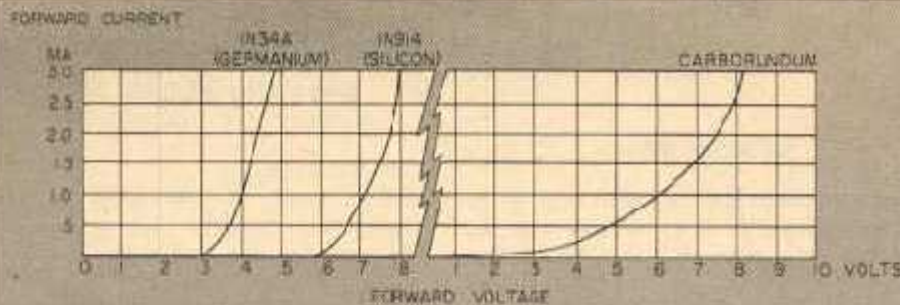

As you can see, the minimum forward voltage for carborundum to forward conduct is very nearly ten times that for germanium. This is the reason that our Grandpa's Whisker requires a bias battery. Moving the threshold down allows weak RF signals to be detected.

on opposite sides of the base of the coil form, mount two brackets, and the tuning coil is completed.

#### Detector Assembly Construction.

Most of the crystal detector assemblies available nowadays are of a horizontal type; designed for fine adjustment of a galena crystal. The carborundum crystal requires a heavier catwhisker pressure than the galena crystal, so the detector assembly (as shown in the drawing) is constructed in a vertical configuration.

Begin construction by cutting a 2-inch x 3/4-inch x 1/4-inch wood section, and then gluing or using wood screws to fasten it to a 2 1/2-inch diameter x 1/4-inch high wood base. This wood base is readily available from art, or hobby, supply stores that stock wood plaques. Or, a suitable base can be cut out of a section of plywood. The dimensions of the detector assembly are not critical and should be modified as necessary to fit your particular crystal mount and catwhisker configuration. If necessary, the rivets holding the catwhisker mount to a metal strip can be

drilled or ground out, and then reassembled with a solder lug as shown in the drawing.

Mount the crystal holder on the base of the detector as shown in the drawing and photos, and then mount the catwhisker assembly on the vertical section with small wood screws, or machine screws and nuts. Make sure that the crystal holder screws do not protrude below the base bottom. Connect a lead between a solder lug on the catwhisker assembly and a terminal clip mounted on the base. If the crystal cup does not have an attached metal strip and terminal clip as in our model, it will be necessary to mount a solder lug with the cup and connect a lead to a terminal clip mounted on the base.

**Receiver Construction.** Most of the receiver components are mounted on a 8 1/2-in. x 7 1/4-in. x 3/4-in. wood base. The base dimensions are not critical and any size wood base can be used that will be large enough to mount the components as shown in the photos. The model wood base shown was obtained from an art supply store and was

originally intended for use as a wood plaque. Small wood screws were used to hold most of the components on the base, except the variable capacitors C1A-C1B and C2 are mounted with machine screws in countersunk holes drilled through the base bottom, if the particular capacitors in your model do not have tapped bottom holes, metal brackets must be fabricated to fit either front or back capacitor mounting holes. The Bias Adjustment Control R1 is also mounted on the wood base with a metal bracket.

Begin construction by locating the component mounting holes on the wood base, and then mounting the parts as shown in the photos. Install solder lugs on all of the terminals J1 to J6 and also on the metal frames (rotors) of the variable capacitors C1A-C1B and C2. Install the detector assembly with three wood screws to the wood base and then install L1 positioned as shown in the photos (with the taps facing the detector assembly).

Wire the components as shown in the schematic diagram and position the wiring for short, direct connections. Install a clip on the lead to C1A-C1B and also on a lead to J7 of the Detector Assembly (the connection to the catwhisker). These clips will be connected to the coil taps during operation of the receiver. Install knobs on the variable capacitors and also on the Bias Adjustment Control, then mark the terminals with rub-on lettering or with small slips of type, paper designations cemented on to the board.

**Operation.** All types of crystal set receivers require a good, outside antenna and a good ground for best results. If you are located near a high-power radio station, an inside antenna and a waterpipe ground will probably work. For distant stations, an outside antenna, 50 to 100 feet long will be necessary. Check the mail order houses for supplies and antenna kits.

The taps on L1 are provided to compensate for antenna loading as well as for the loading effect of the carborundum detector. The position of the clip leads on the coil taps must be determined by experiment as they will vary according to the length (loading) of your antenna and the frequency of the radio station being received. Inasmuch as the carborundum detector also requires adjustment (both in determining a sensitive crystal point and in the proper bias voltage adjustment), a saving in initial L1 tap set-up time can be achieved with the use of a fixed crystal diode (IN34A, or equivalent germanium type).

Grandpa's Whisker is a nostalgic look back at the days when a ship's radio lifeline to shore was dependent on no more than a coil, a battery, a catwhisker, and carborundum.

(Continued on page 116)



## Grandpa's Whisker

*(Continued from page 31)*

*CAUTION. Make sure that the battery is disconnected for this initial adjustment.*

Connect an antenna to J1, a ground to J2, and a pair of high-impedance headphones to J5 and J6. A pair of 2000-ohm phones was used with our model; do not use low impedance headphones (8, or 16 ohm stereo types). Do not connect the 6-volt battery at this time.

Make sure that the catwhisker is not touching the crystal or the crystal cup (open circuit to the carborundum crystal), and then connect the crystal diode across J7 and J8 (the polarity is not important; it will work either way). Connect both of the clip leads (lead to J8 and lead to C1A-C1B) to L1 coil taps; any of the mid-coil taps will do for an initial start. Set C1A-C1B to mid-capacity range; and then tune C2

until you hear a radio station in the headphones. Readjust the setting of C1A-C1B for best headphone volume. Then readjust each one of the clip leads for best headphone volume of the received radio station. All of the adjustments and coil tap settings will interact, and will require careful retuning of both C1A-C1B and C2 for best results.

When a radio station is tuned in for best headphone volume, carefully disconnect the germanium crystal diode from J7 and J8 without disturbing the tuning capacitor settings or the positions of the L1 tap connections. Then place a carborundum crystal in the detector assembly and connect the 6-volt battery to J4 (negative lead) and J3 (positive lead). Adjust the catwhisker until it touches the carborundum surface and then set the bias control R1 to mid-range.

Carefully adjust the catwhisker for a sensitive spot on the crystal surface at the same time adjusting R1 for best volume of received signal. If this seems like a lot of trouble to hear a radio station, remember the radio pioneers

around the turn of the century would spend considerable time with equipment even cruder than Grandpa's Whisker in order to capture the elusive wireless signals. After a station is found with the carborundum detector, it may be possible to achieve a bit more received volume by readjusting the coil taps and tuning capacitors.

You can experiment with different types of silicon and germanium crystals as well as other materials with this circuit; but remember, do not use the battery unless it is with a carborundum crystal. The battery will burn out the more conventional germanium and silicon crystals. You can also try chips of carborundum broken off of sharpening stones, etc. and held with melted solder or lead. Or you can also try packing the crystals with sections of crumpled aluminum or lead foil in place of the melted lead bodies. The received crystal set volume will vary according to the type of crystal used; generally germanium will be loudest, and silicon a bit less, and the carborundum crystal will usually be lower in volume. ■



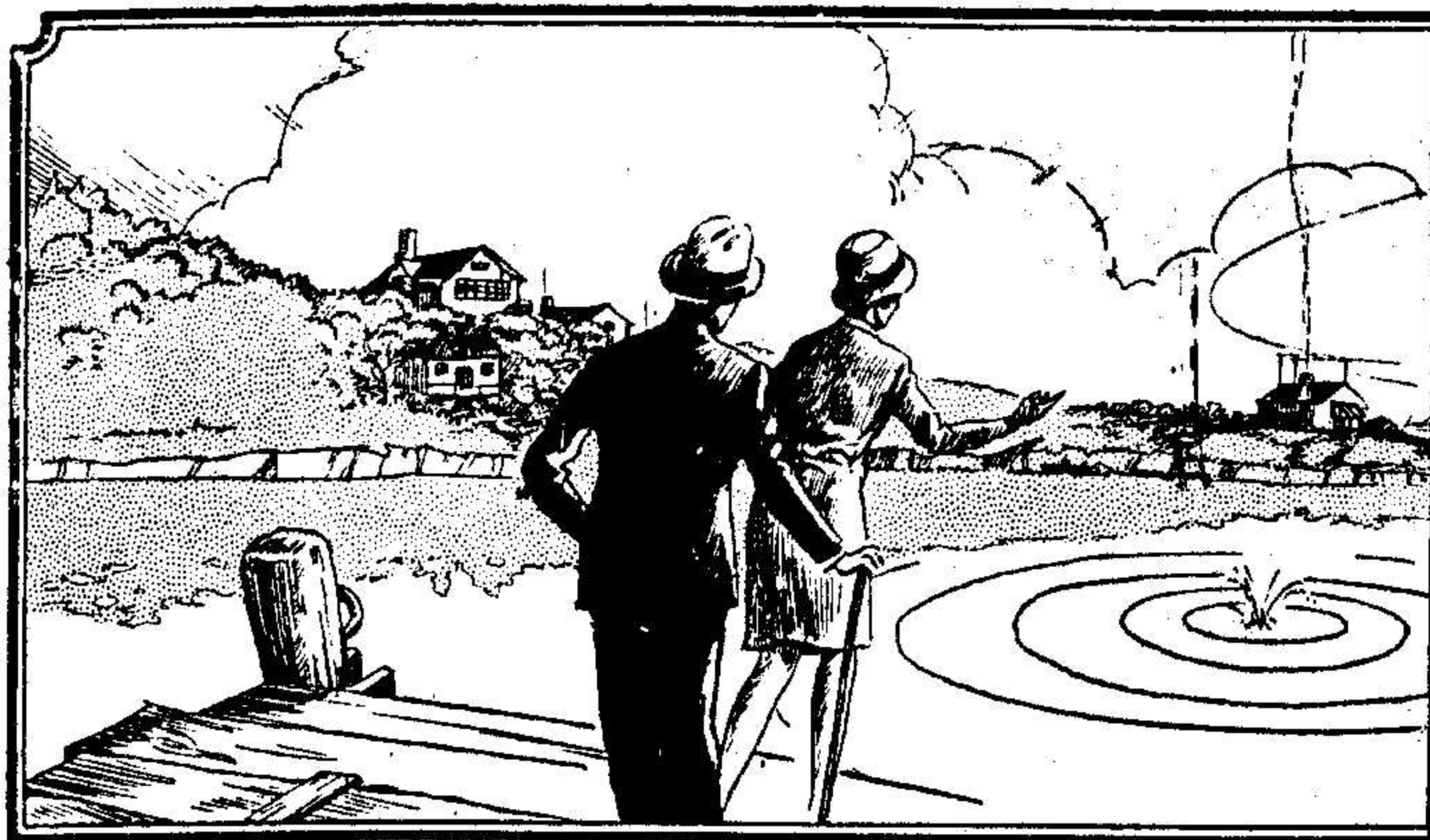

A stone, thrown in the water, causes waves to radiate in ever-widening circles

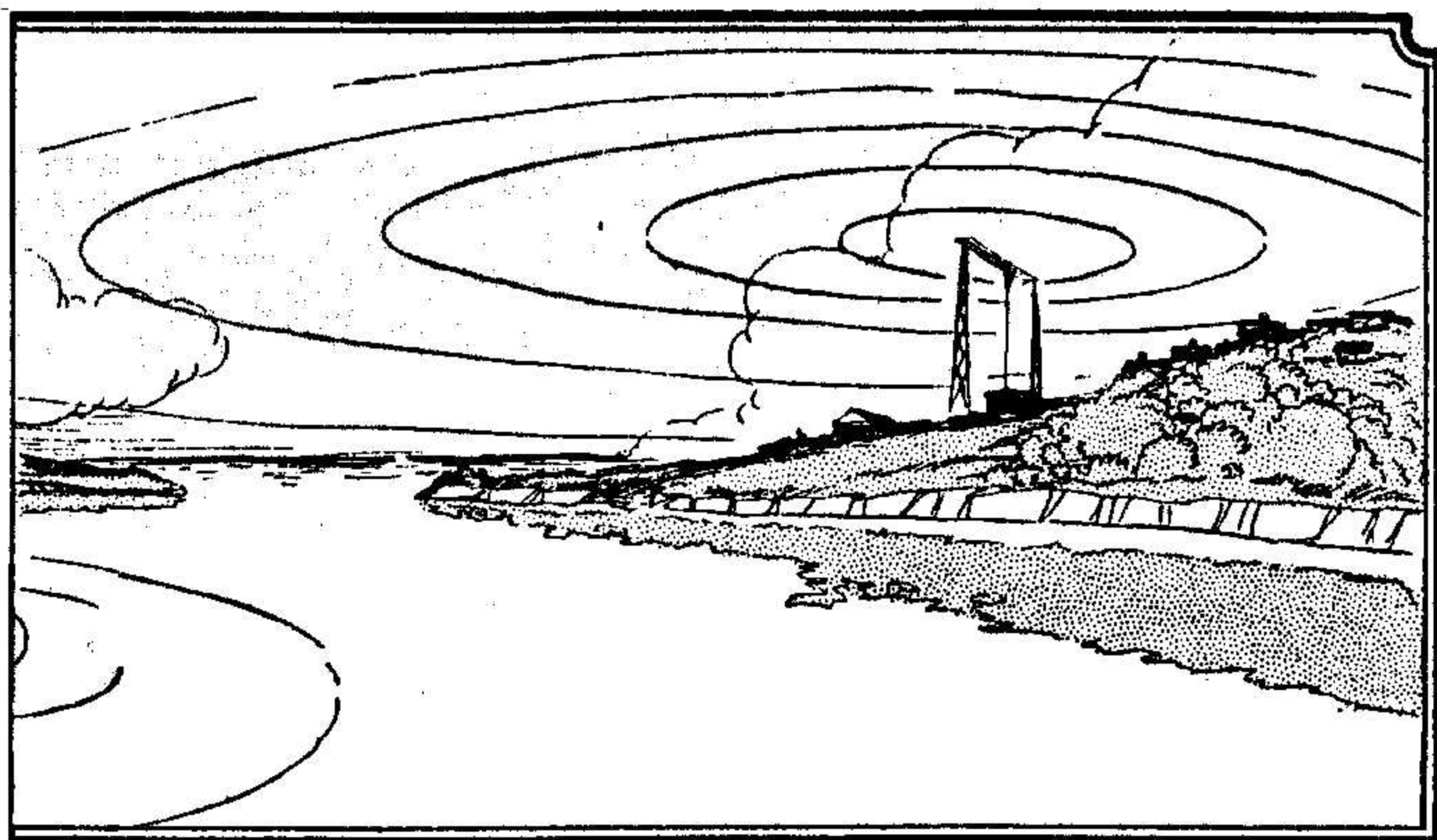

The waves from the antenna of a radio station, while not visible, are radiated in much the same manner



# The Junior RADIO Guild



LESSON NUMBER SIX

## The Fundamentals of Radio

ONE of the first questions which the beginner in radio is apt to ask is "how does a radio station send out its signals?" To answer this so that you will get a clear idea of the action involved, suppose we make use of an analogy for an example. Time and again this simple analogy has been employed and will serve again here. Supposing you throw a stone into a body of water, say, a lake. You will notice that as the stone strikes the water, waves of a circular form are set up and slowly expand in radius until perhaps the force of the impact is totally expended. (See the picture above, to the left).

In general, this is what happens when a signal is sent out from the antenna of a radio station. That is, the waves, carrying the signal, radiate into space, only the speed with which they travel is very rapid—186,000 miles per second.

Now, going back to our lake, supposing at some distance from where the stone struck there was a bit of wood floating quite serenely. When the waves radiated by the stone reached the wood it would bob up and down on the waves. In other words, the waves set up by the throwing of the stone have imparted a motion to the bit of wood.

Similarly, if we can have an antenna erected on our roof, then the waves set up by the broadcasting station's antenna will strike it and a portion of the wave will be absorbed and passed along to whatever receiving apparatus is attached to it.

If there are many pieces of wood in our lake, all within range of the waves set up by the stone, each one will be affected and will bob up and down. Similarly if there are many antennas within range of the waves broadcast by the antenna of the radio station, then each one will absorb a minute

**THE** Junior Radio Guild is an organization whose membership is composed of boys who are interested in learning more about radio.

This organization, under the direction of the Technical Staff of RADIO NEWS, has prepared a series of lessons for beginners. The lesson printed here deals with the fundamentals of radio.

Future lessons will show you how to build another type of radio receiver.

If you wish to join the Junior Radio Guild, fill out and send to us the coupon on page 672.

portion of the wave and will affect the receivers attached to them.

This, of course, will explain only roughly the general way in which broadcasting stations and receivers affect each other. There are many ramifications which enter into the rather complicated system of radio transmission, but for the purpose of drawing a simple parallel here it will not be necessary to go into the technical details involved.

### At the Other End of the Receiving Antenna

The radio signals which are absorbed by the receiving antenna are of such a nature as to be inaudible to the human ear. They are composed of vibrations which occur so rapidly that, without the proper kind of apparatus, we cannot hear them directly. Therefore, what this apparatus does is to convert these rapid vibrations into sounds that are intelligible to us. This apparatus we call our receiving set, and during all the years of progress in the radio art these receiving sets have grown from simple crystal sets to the rather complicated multi-tube receivers we have with us today.

To the beginner, however, the crystal receiver, so called because it makes use of a piece of galena or silicon crystal to convert or rectify the transmitted signals so that we can hear them, still commands a great deal of interest because it is simple to build, easy to operate and requires no batteries to make it function.

The wave which is transmitted from the antenna of the broadcasting station is what is called a carrier wave. That is, it carries the voice or music vibrations, which are superimposed upon it, from the microphone which is in the broadcasting studio. The carrier

Fig. 1

The circuit of a simple crystal receiver. S1 and S2 are contact switches; L is a coil wound as described in the text; C1 is a variable condenser of .00035 mfd.; R is a crystal detector; C2 is a .002 mfd. fixed condenser, and P a pair of headphones

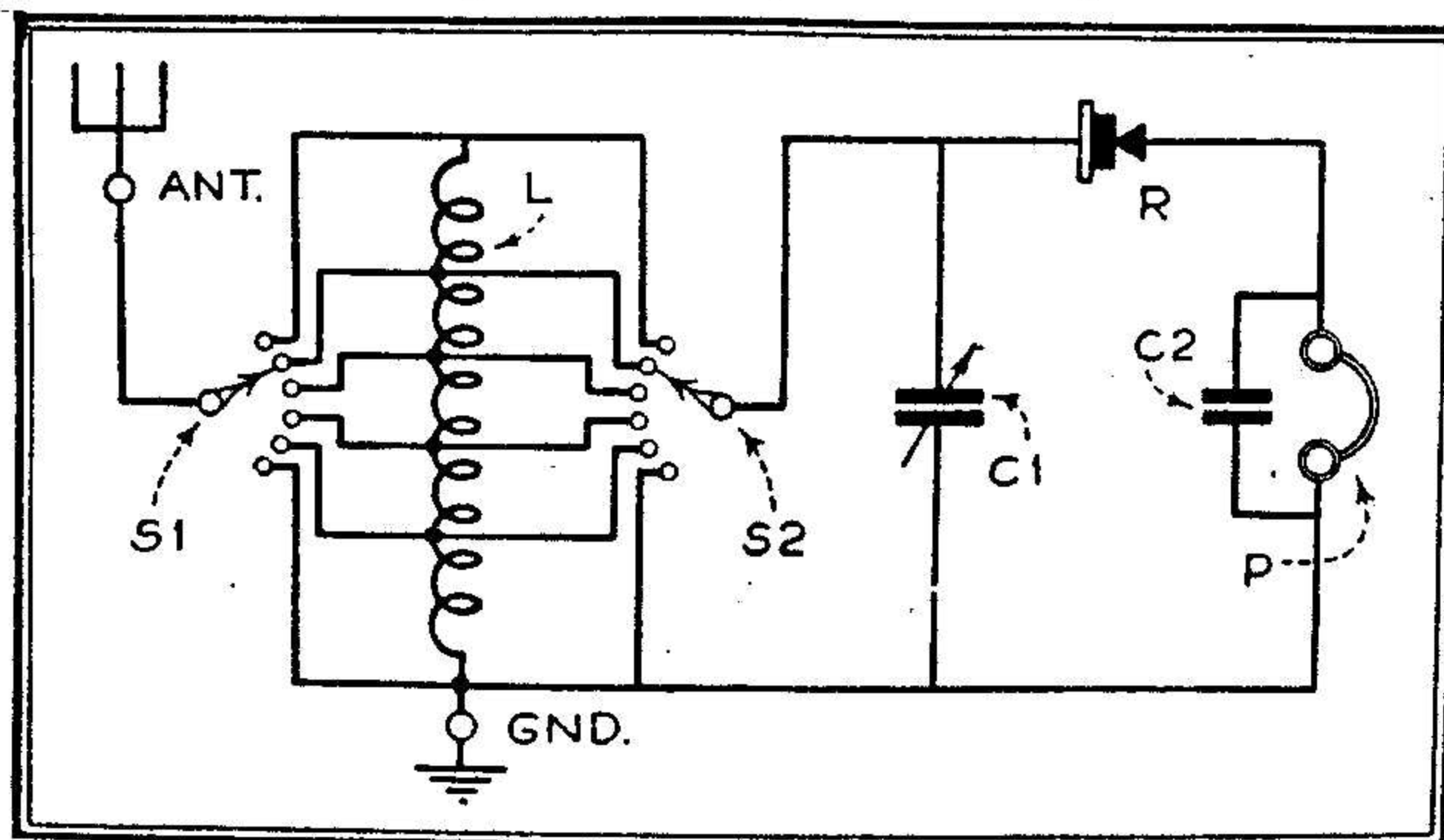



FRONT PANEL LAYOUT

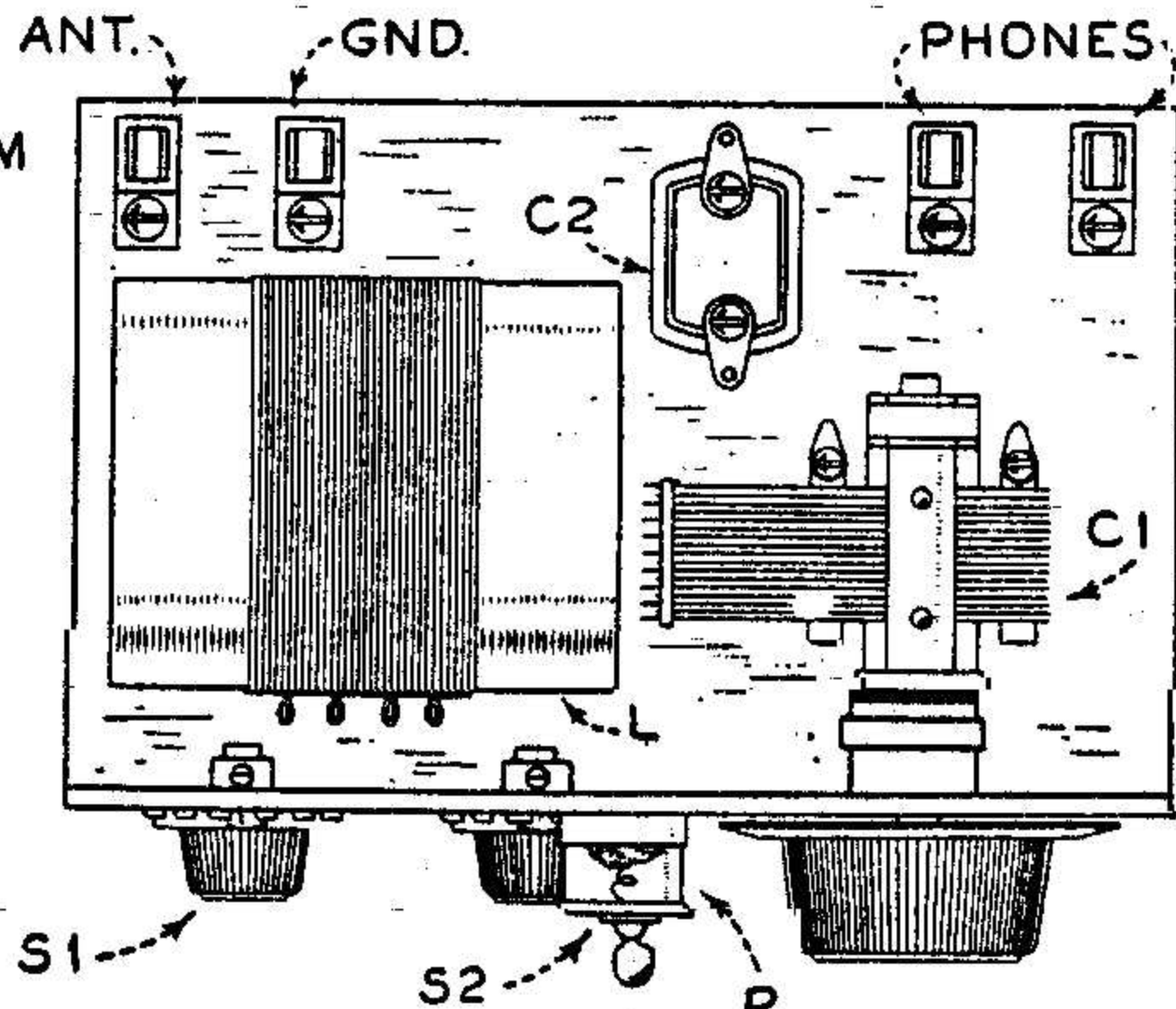
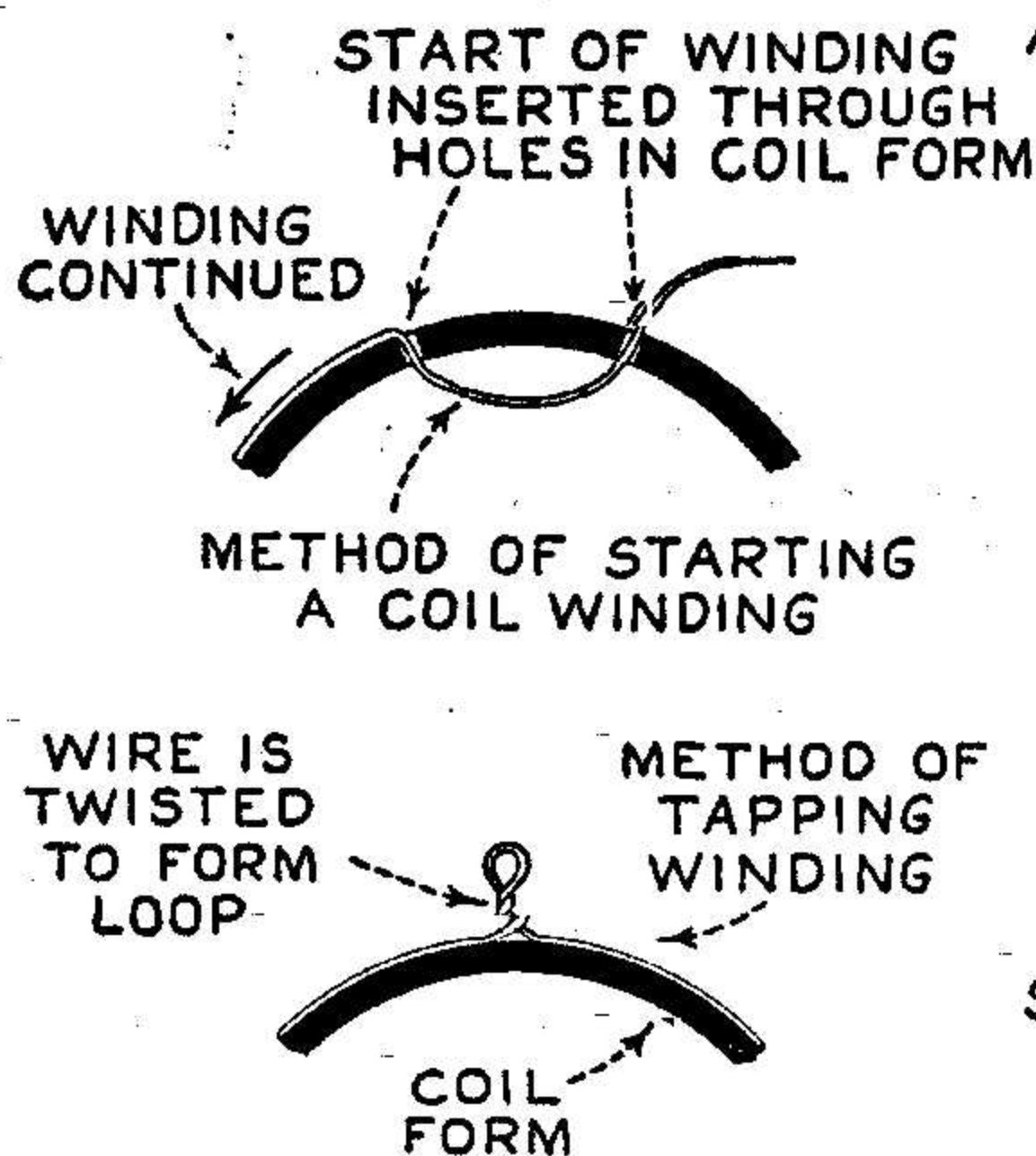
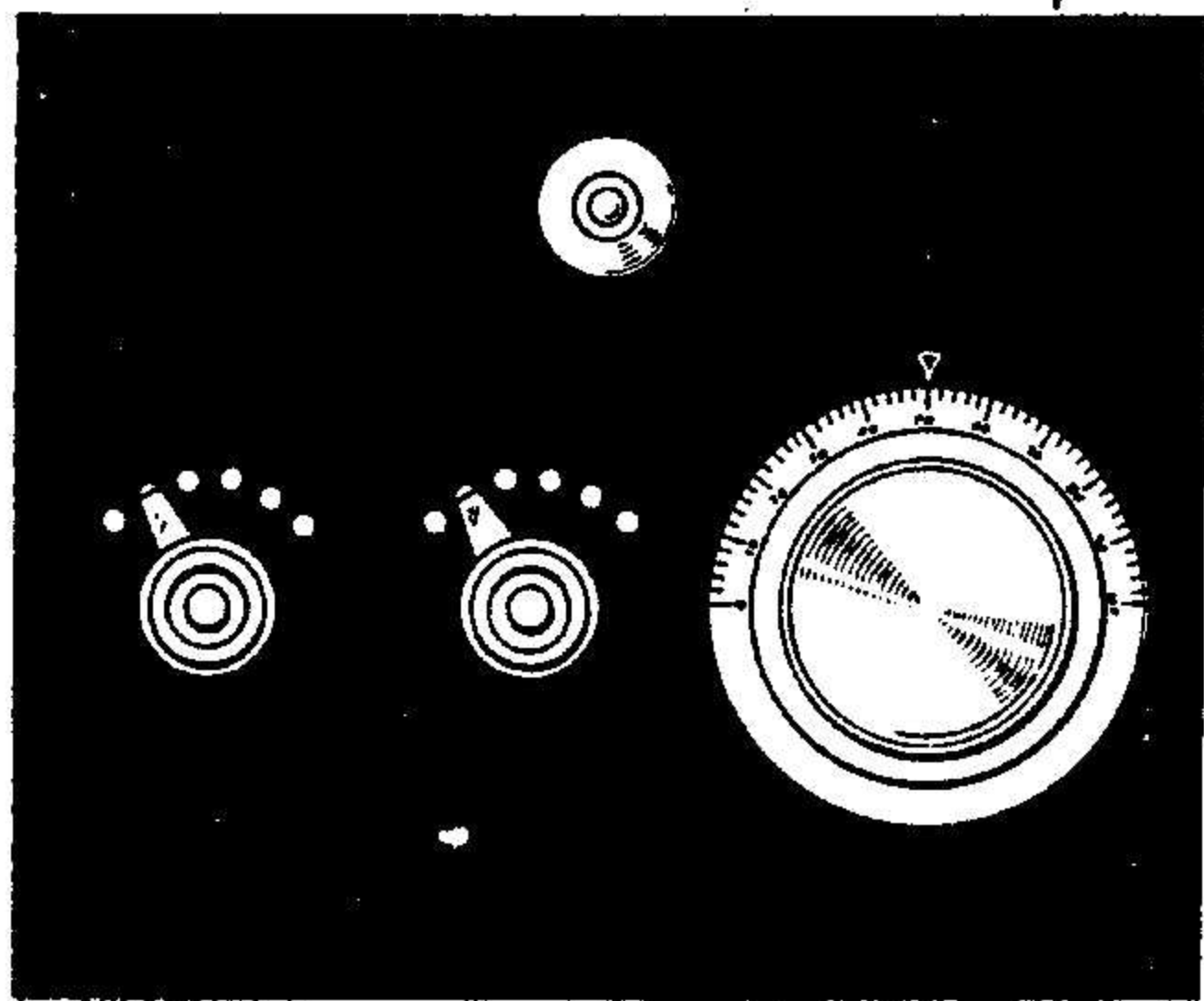

ASSEMBLY OF A SIMPLE CRYSTAL DETECTOR UNIT

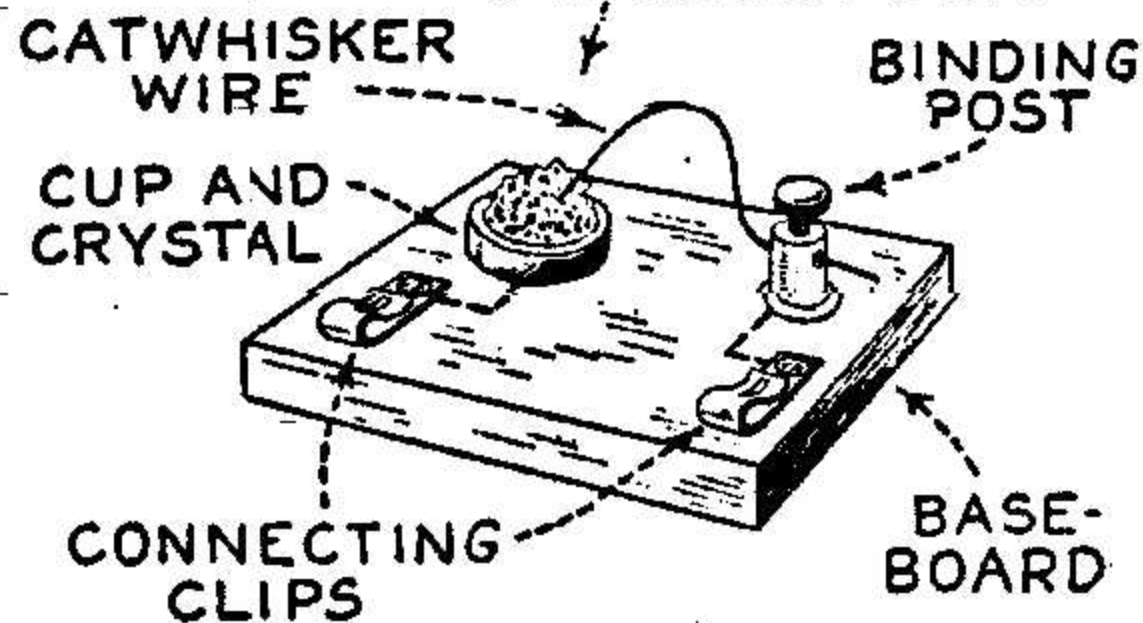
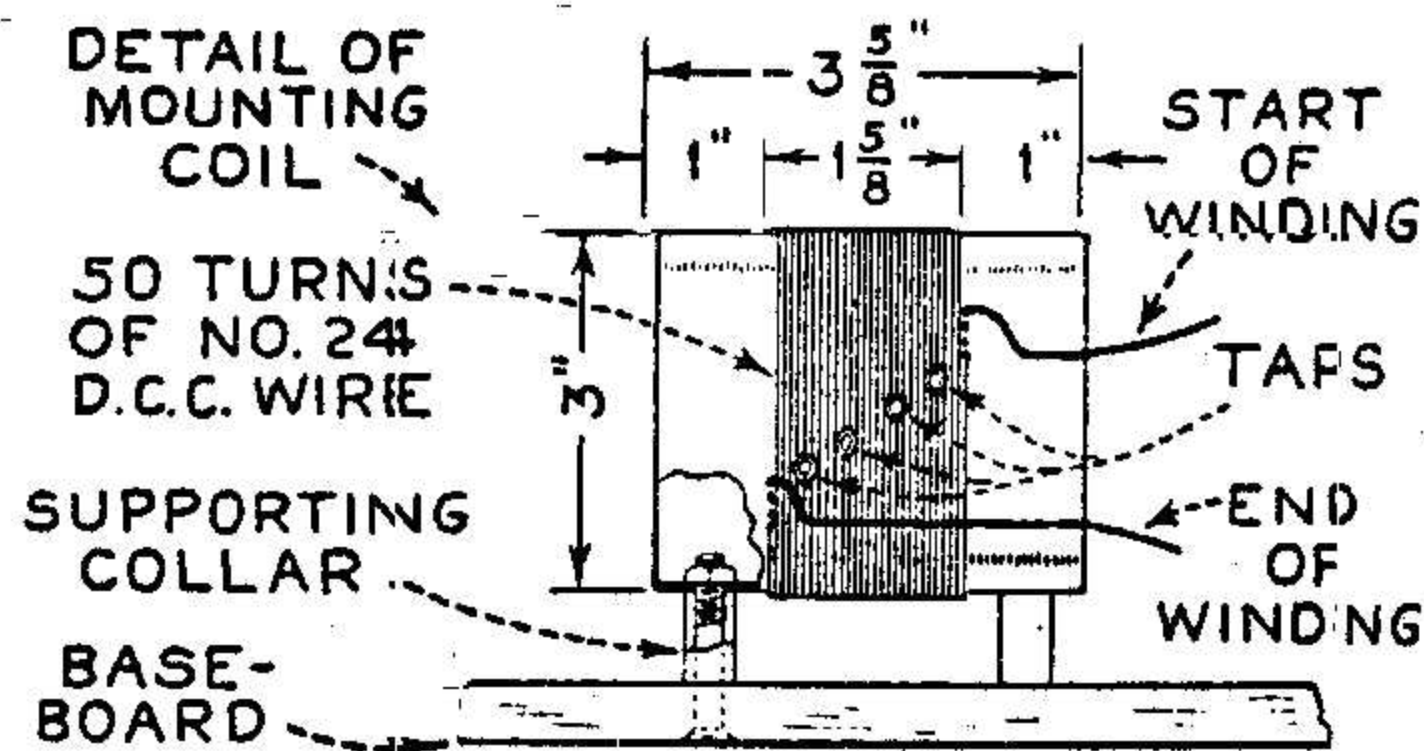

Fig. 2

All the information you need for building the simple crystal receiver whose circuit is shown in Fig. 1 is given here. If you do not wish to buy a manufactured type of crystal detector one can easily be made as shown here



wave form is shown in A, Fig. 3. Note that the amplitude, or in other words, the strength of one vibration, is as strong or equal to the others. However, when the voice currents from the microphone are passed along to it through the various amplifiers which are employed in the studio control room then the shape is varied as shown in B. Here the minute variations of current, or vibrations of different amplitude, change the shape so that there are various heights of hill and valley, so to speak, on either side of the center line.

These rapid vibrations, occurring at such a speed as to be inaudible to the human ear, are radiated from the antenna of the station and, as explained previously, are radiated into space.

When they reach a receiving antenna where the receiving apparatus, that is, the coils and condensers, have been adjusted to tune to those particular signals, they are absorbed and passed on to the crystal detector. Here, they are caused to operate the crystal detector so that, while it does not register the minute changes of each vibration, it does register the difference between vibrations, or in other words, only passes on to the phones that current which may be indicated by the envelope-shaped curve in C of Fig. 3.

The amount of signal which is heard in the phones depends largely upon first, the tuning qualities of the coil and condenser to tune only to the desired signal, and secondly, upon the sensitivity of the crystal detector. Through practice, a sensitive contact can be found on the crystal which will give the maximum amount of signal.

**How to Build a Crystal Receiver**

One of the simplest of these crystal receivers is described here and is repre-

sented diagrammatically in Fig. 1. Here we have a coil, L, consisting of 50 turns of No. 24 d.c.c. wire on a cylinder 3 inches in diameter by 3 5/8 inches long. The actual winding space occupies 1 5/8 inches, leaving a margin at each end of 1 inch.

The coil is tapped at every fifth turn, the tap being brought out to a double set of switch taps, indicated by S1 and S2. To the end of the coil and S2 is connected a variable condenser C1 which, with the two switches, tunes the receiver to the desired signal. The tuned-in signal is then rectified by the crystal R and fed to the headphone P. Across the headphones is connected a fixed condenser so as to make the signals of stronger intensity in the headphones.

All of the apparatus can be mounted on a board about 9 inches square and arranged as shown in Fig. 2.

end of the wire through the holes to fasten it and then begin winding.

At every fifth turn, as the winding of the wire advances, the wire is twisted in a loop as shown, until all fifty turns are completed.

Connection of the various pieces of apparatus is shown quite clearly in the accompanying sketches.

To operate the receiver some random adjustment of the switch S1 will have to be made until you become acquainted with the manner of operating the set. Set switch S2 at the top of first tap and then slowly rotate the knob of the variable condenser until a signal is heard. If you have a manufactured type of crystal detector, then all that will be necessary to obtain a clear signal is to touch the fine pointed wire to various spots on the surface of the crystal until the most sensitive one has been found. The drawing shows how a home-made one can be made.

Next month the Junior Radio Guild Lesson No. 7 will describe radio symbols as used in the preparation and reading of circuit diagrams and will outline the first unit of a vacuum tube receiver which will be described in future lessons.

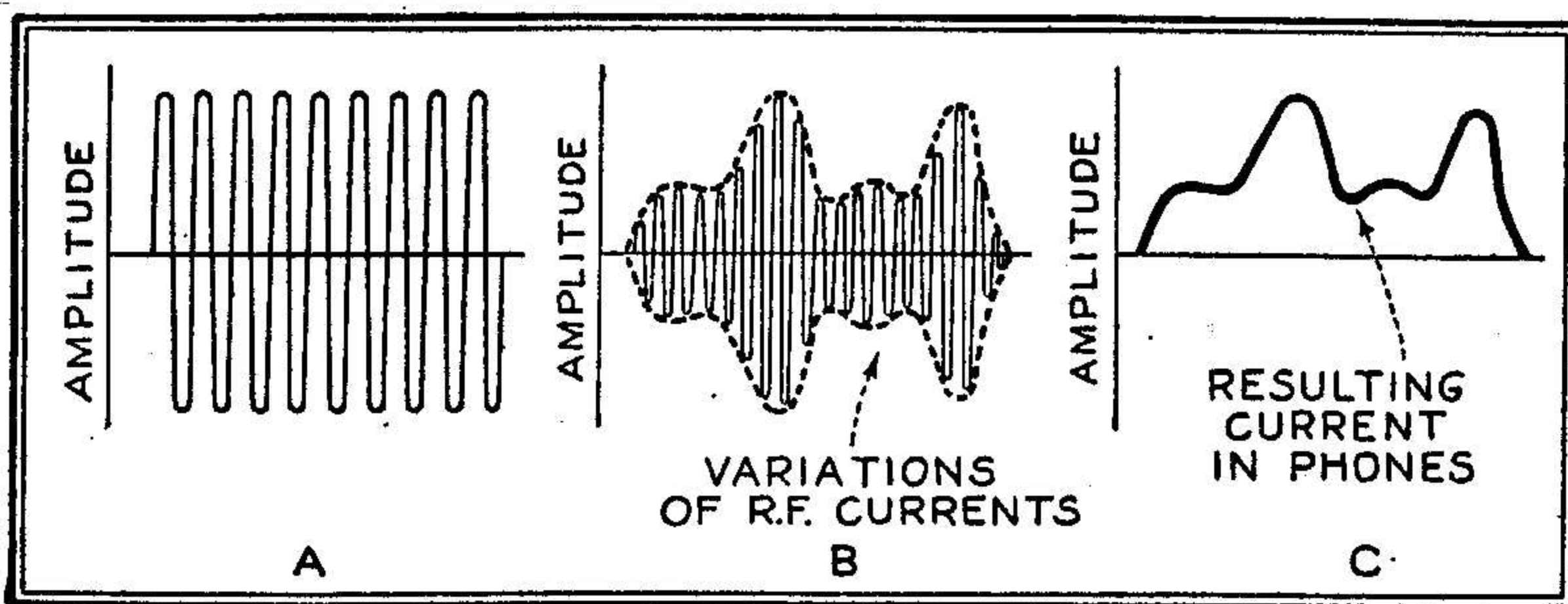

Fig. 3

At A we show the continuous wave or carrier waves set up by the oscillators at the transmitter; in B the microphone current has changed the form of this wave to conform with the variations in the speech or music which is being broadcast; at C is shown the form of the current variation which operates the diaphragm of the headphones attached to the crystal set

The coil for this simple receiver is wound as follows:

Punch two holes close together about 1 inch from the edge of the tube, pass an

**YOU** or your friends may join the Junior Radio Guild merely by sending us the membership coupon (properly filled out) which is printed on page 672 of this issue. There is no age limit, nor do we require that you have any previous training in or knowledge of radio. Of course, if you are familiar with radio, know how to read circuit diagrams or build a set, so much the better. The lessons will then help you to review what you already know.



## LESSON XIX

### RADIO

---

**Radio on the Farm**—The progress has been so rapid with radio in recent years that it has now become possible to enjoy the advantages of radio on almost any farm. The family in the country which not long ago seemed far away from public life and the many influences which make life worth living, may now sit in a comfortable room in the farmhouse and enjoy concerts by some of the best artists in the country, lectures by men of prominence, sermons by big church men, and weather forecasts and market and crop reports, as well as daily signals of correct time. Besides this, there are many other phases which interest young people on the farm. Many young people are not able to attend the athletic contests in the colleges and universities but still have great interest in them. By means of the radio, they can have accurate reports of the contests, play by play, even hearing the sound of the referee's whistle and the cheers of the spectators as well as other noises of the game.

The weather forecasts and the market and crop reports probably mean more than any other phase of the use of the radio on the farm. Unless the farmer is very near a large city, he can secure these reports a full day or more ahead of the reports in the newspapers, and sometimes this advance information will enable him to get a much better price for his stock or farm produce than he would get if he had to wait for later reports.

**Fundamental Principle of Radio**—A radio sending station sends messages by means of the antennae in the form of aerial currents or electric waves which spread in all directions from the point, at intervals. The space or distance between each successive current or wave is commonly called "wave length." Certain stations are confined to sending messages with a certain wave length. This is done to avoid conflict or interference on the part of different stations in the air. These waves, in spreading through the air over the country, affect the antennae or aerial wires, which are over or in the house where a receiving radio set is located. These vibrations are carried down by means of a wire connection to the receiving device in the room of the person who wishes to listen to the message. The problem of the receiving station is to select the particular



series of waves from the station to which it wishes to listen and to sift out the undesirable waves from all other stations. A device which is called the "coupler" will help a great deal in shutting out the undesirable waves.

### Radio Receiving Outfits

**Crystal Detector Set**—The Crystal detector sets are inexpensive and can be very easily made by the beginner. However, messages cannot be received by these outfits at a greater range than from twenty-five to fifty miles. With some of the more simple outfits, sometimes messages are not very distinct at even five or ten miles. With the addition of various devices, the messages can be amplified and brought in stronger at a considerable distance. Unless one is within twenty-five miles' radius of a large city, he cannot hope to do much with a crystal detector outfit from the standpoint of actual service as a business investment. It is well for a boy, however, to start with a crystal detector outfit and learn the operation and care of the receiving device before an investment is made in expensive apparatus. There are so many kinds of outfits on the market, and so many concerns that manufacture different parts with which a receiving set can be constructed, that exact prices cannot be given with accuracy. Dissatisfaction usually results from investment in a very cheap set which is sold by unscrupulous dealers from fifty cents up to several dollars. As a general rule, one can construct his own outfit after having purchased the necessary parts at nearly half the price which is asked for the assembled outfits.

### A Homemade Crystal Detector Outfit

(")=inches; (')=feet

#### Materials Needed for a Simple Set—

- 3 pieces  $\frac{1}{4}$ " x  $5\frac{1}{2}$ " x 6" for sides of cabinet
- 2 pieces  $\frac{1}{4}$ " x 6" x 8" for top and bottom of cabinet
- 2 pieces  $\frac{1}{4}$ " x 6" x 8" for the back and front panel
- 2 pieces  $\frac{1}{4}$ " x  $5\frac{1}{2}$ " x  $5\frac{1}{2}$ " for ends of coil box
- 2 small cleats 6" long
- Some small brass brads
- 1 oatmeal box
- 2 rotary switch levers
- 12 switch points
- 4 binding posts
- 2 small brass wood-screws
- A small phone condenser
- 1 large brass binding post



- 1 brass rod  $\frac{3}{8}$ " x 2"
- 4 brass bolts and nuts
- 65 ft. No. 22 cotton-covered copper wire
- Several feet of "spaghetti tubing"
- 1 small piece No. 28 copper wire, about 8 in.
- 1 piece galena, as a detector

**The Cabinet**—When constructing a radio set, extreme care must be used throughout as the pieces must fit accurately. While oak makes a better appearance, most any kind of wood may be used. With the brass brads, nail the cabinet together so the sides are between the top and bottom. Then nail the back on, bringing all edges flush,

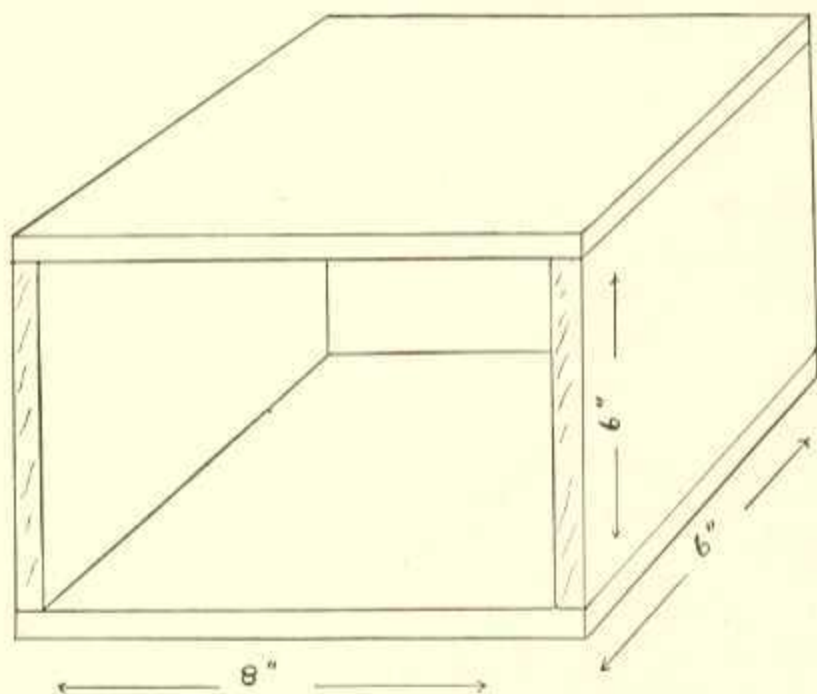

FIG. 1.—The Completed Cabinet without the Panel or Front Piece.

**Making the Panel**—The panel can be made either of bakelite or of some hardwood, such as oak. Bore four  $\frac{1}{4}$  in. holes in the panel, as suggested by the illustration. Two of the holes are for the switches. These two are 2 in. up from the bottom of the panel and  $2\frac{1}{2}$  in. in from each end. The other two holes are for the detector. These are drilled 2 in. down from the top and 3 in. in from each end. The cabinet and panel should now both be given a coat of shellac. Do not use a stain with lampblack or any sort of paint. If bakelite has been used, the shellac will not be necessary.



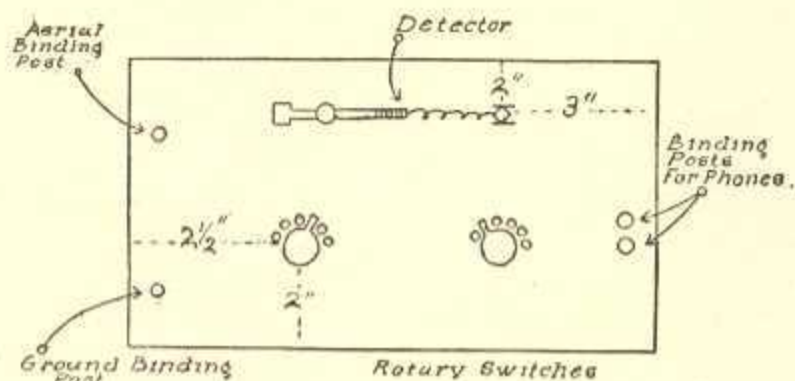

Fig. 2.—The Completed Panel.

**Winding the Coil**—The tuning coil for the Crystal Detector is wound on a cardboard tube 6 in. long and 4 in. in diameter. Usually, a small oatmeal box or some round paper box can be cut down to 6 in. and used for this purpose. No. 22 cotton-covered, copper wire is wound around this sixty times. First make two small holes about an inch apart at one end of the tube and run the end of the wire in and out of this to hold it in place. Then wind five turns of the wire, making a loop each time a turn is finished. See illustration for method of making loops. To make a loop, punch two holes in the box, make a fold as illustrated, push it in the one hole and out the other and twist it several times. From here on, make a loop at the end of every ten turns, repeating this process until five more loops have been made, or ten loops in all. Finally, make five more turns. Run the end of the wire in and out of two holes as you did at the beginning, to keep in place.

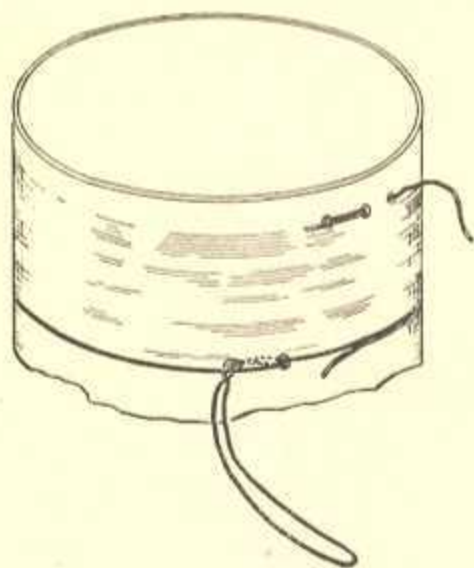

Fig. 3.—Method of Making a Loop.

**Assembling the Tuner**—Cut two pieces of  $\frac{1}{4}$  in. material 5 in. square. With small brass brads, fasten a cleat on each end and cut a hole in the end of the oatmeal box on each side, through which this cleat will slip, in order to hold the end piece to the oatmeal box.

**Mounting Switches**—The two rotary switches are mounted in the holes as shown by the drawing, and the six switch points are mounted



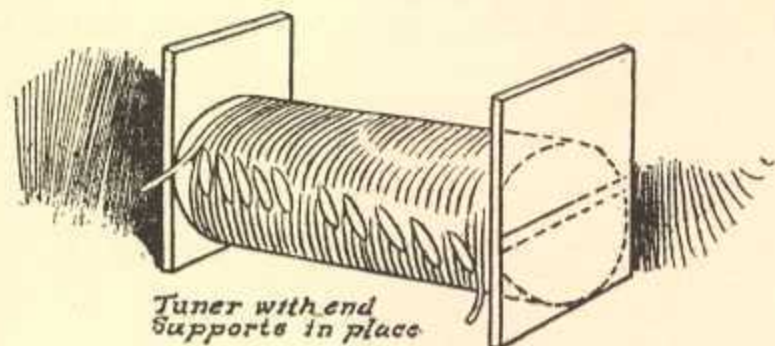

Fig. 4.—How to Fasten Ends to Oatmeal Box.

in semi-circular fashion around each lever. Two binding posts are mounted on the left side of the panel, one for the aerial and one for the ground. The other two binding posts will be mounted later.

Connect a wire from the left hand switch lever to the upper binding post at the left. Also connect a wire from the right hand switch lever to the lower binding post. These wires must be insulated and placed on the back of the panel. Use the same wire for this as you used for winding the tuning coil.

**Hooking up the Tuner**—The tuner is fastened to the back of the panel with brass screws. The screws pass through the front of the panel into the end supports.

Next connect the end of the coil wire with the first switch point of the left hand switch. The five loops close together are connected in succession to the five remaining points. The loops on the right hand side are connected with the five switch points in a similar way. Remember to scrape the insulation from the wire in making these connections. It is usually advisable to solder every connection.

**Mounting the Crystal**—The small brass strip is bent into a "U" shape and a brass bolt placed through the side holes. The other bolt is placed through the bottom to hold it to the panel. The "U" is mounted in the right hand upper hole, which was bored in the panel. Wrap a fine copper wire around the end of the brass rod and solder into place. Then wrap the wire around a small nail or something in order to coil it into a spring. Finally place the rod through the binding post and clamp the crystal in the end of the brass "U"-shaped piece.

**Mounting the Binding Posts for the Phones**—The two binding posts for the phones are mounted on the panel along the right hand edge. They should be near the middle, about one inch in from the edge, and about one inch apart.

**Mounting the Phone Condenser**—The phone condenser should be mounted on the back of the panel between the end support of the tuner and the phone binding post by means of brass screws. If there are no



eyelets or holes in the condenser for screws, it may be held in place by means of strips of tape.

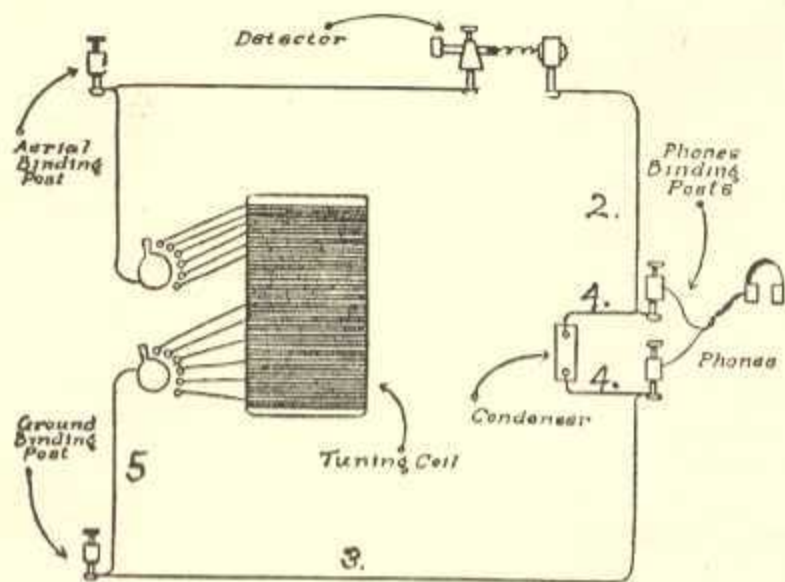

FIG. 5.—Showing the Connections.

**Making the Connection**—No. 22 wire will be used for making the connections. It is advisable to cover the wire with what is known as "spaghetti tubing." Then make the following connections:

1. Run a wire from the aerial binding post to the detector binding post.
2. Run another from the detector clamp to one of the phone binding posts.
3. Connect the ground binding post to the other phone binding post.
4. Connect the condenser to the phone binding posts as shown in the illustration.
5. Connect the right hand switch to its ground binding post.

The cabinet should then be fastened to the back of the panel by means of small brass screws. Use round-headed screws, or countersink flat-headed screws. The illustration (Fig. 6) shows how the aerial is run through the window frame to the detector outfit. Also how the ground wire is connected. The construction of the aerial consists in putting up a 50 or 100 ft. length of single wire stretched between buildings or poles, 25 to 50 ft. above ground, carefully insulated and equipped by a switch of lightning arrester at the entrance to the house.

**Directions for Operating**—To find a sensitive spot on the galena crystal, move the small wire about on its surface. In "tuning in," move the right hand switch over the switch points slowly, one at a time. After



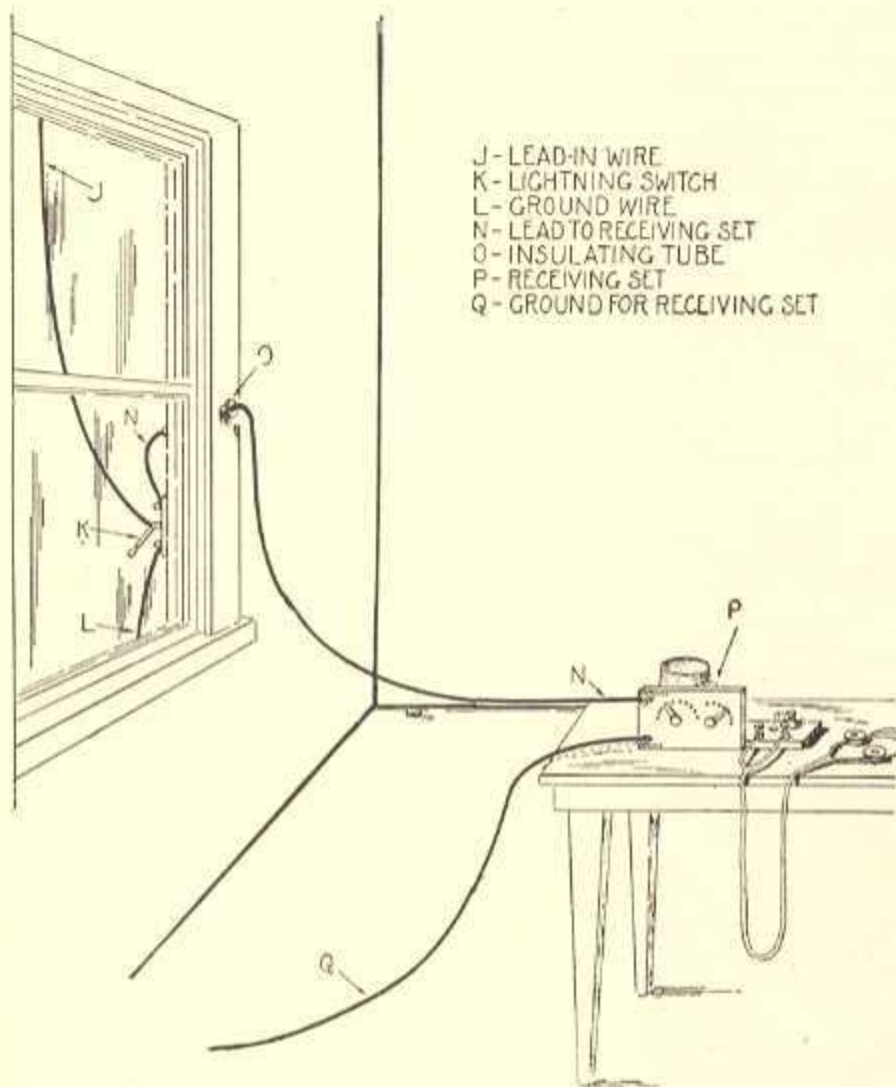

Fig. 6.—Showing How the Aerial is Brought into the House and Connected.

each move, rotate the other switch lever over all points and stop when the desired station is heard.

It is wise to keep a note book at hand and jot down the right location of the switch lever for hearing certain stations.

#### Electron Tube Receiving Outfit

The difference between this and a detector outfit is that an electron tube is used instead of a crystal detector. The tube is more sensitive and has a much greater receiving range, in fact, it is possible to receive messages for thousands of miles with an electron tube set. Various assembled outfits are sold on the market and it usually proves more



satisfactory to purchase the assembled outfit than to try to make one yourself. Various devices have been invented for amplifying the waves, thus making the messages audible to all the people in a room. With all

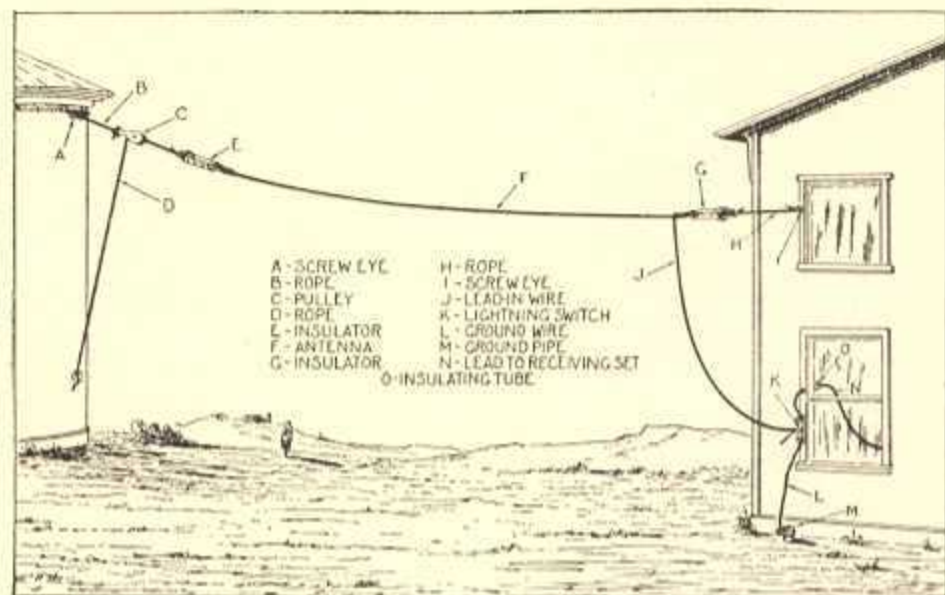

Fig. 7.—Showing How the Aerial is Put Up.

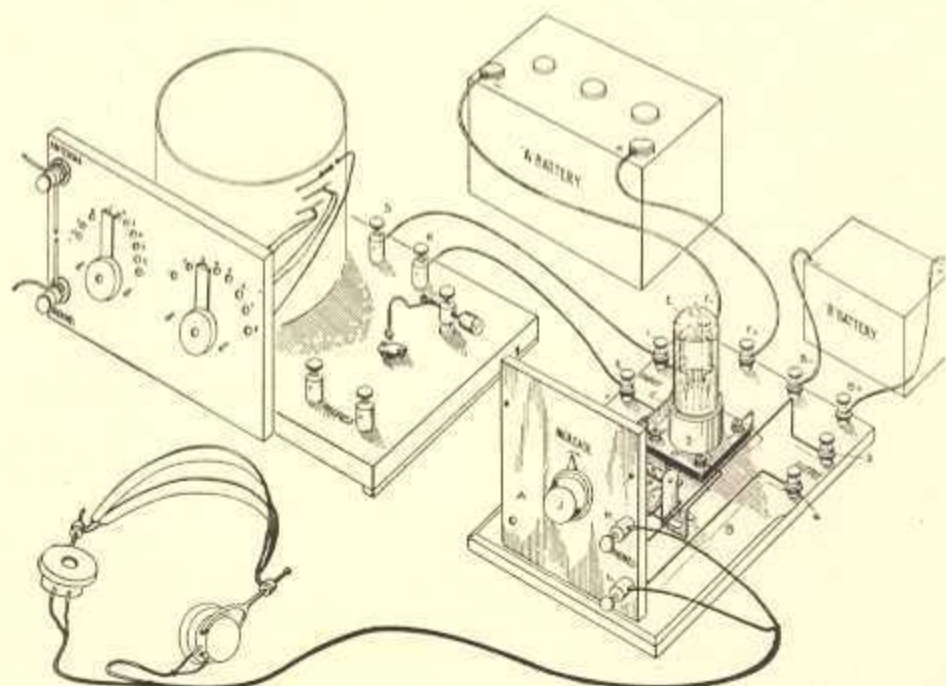

Fig. 8.—Electron Tube Detector Outfit.



these additional devices, it is possible to invest several hundred dollars in a very good outfit. The illustration describes the different "hook-ups" which are possible by adding additional parts to make the set more efficient.

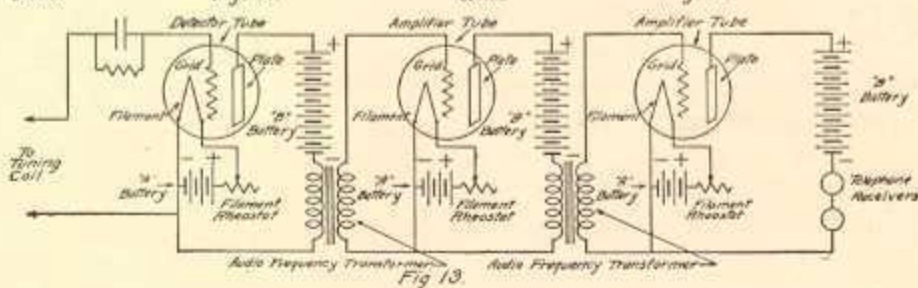
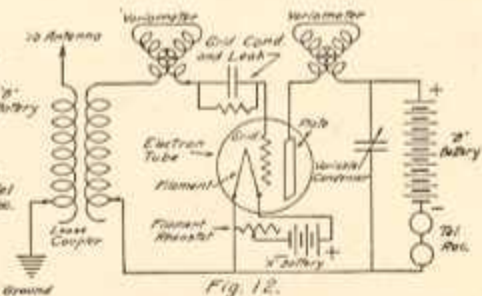
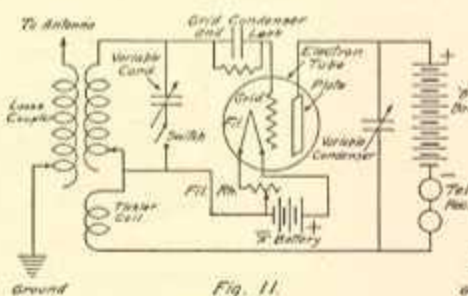
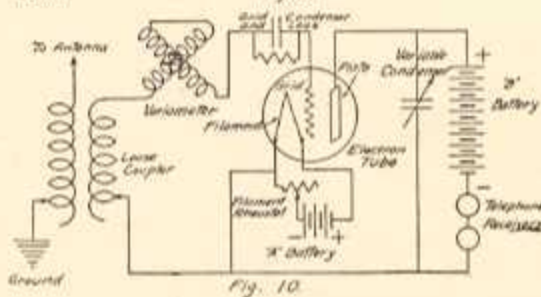
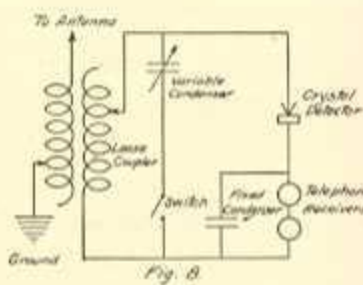
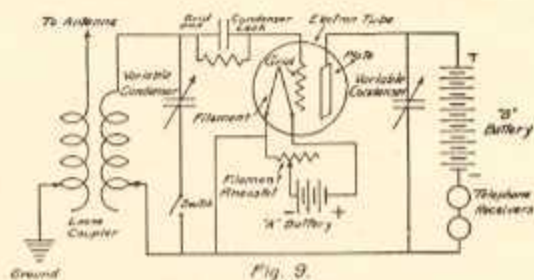
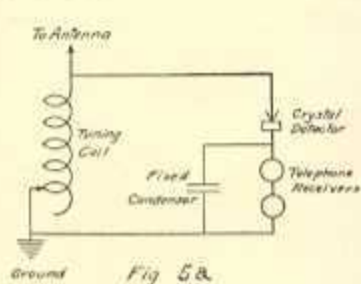

Fig. 9.—Showing Different Hook-Ups.



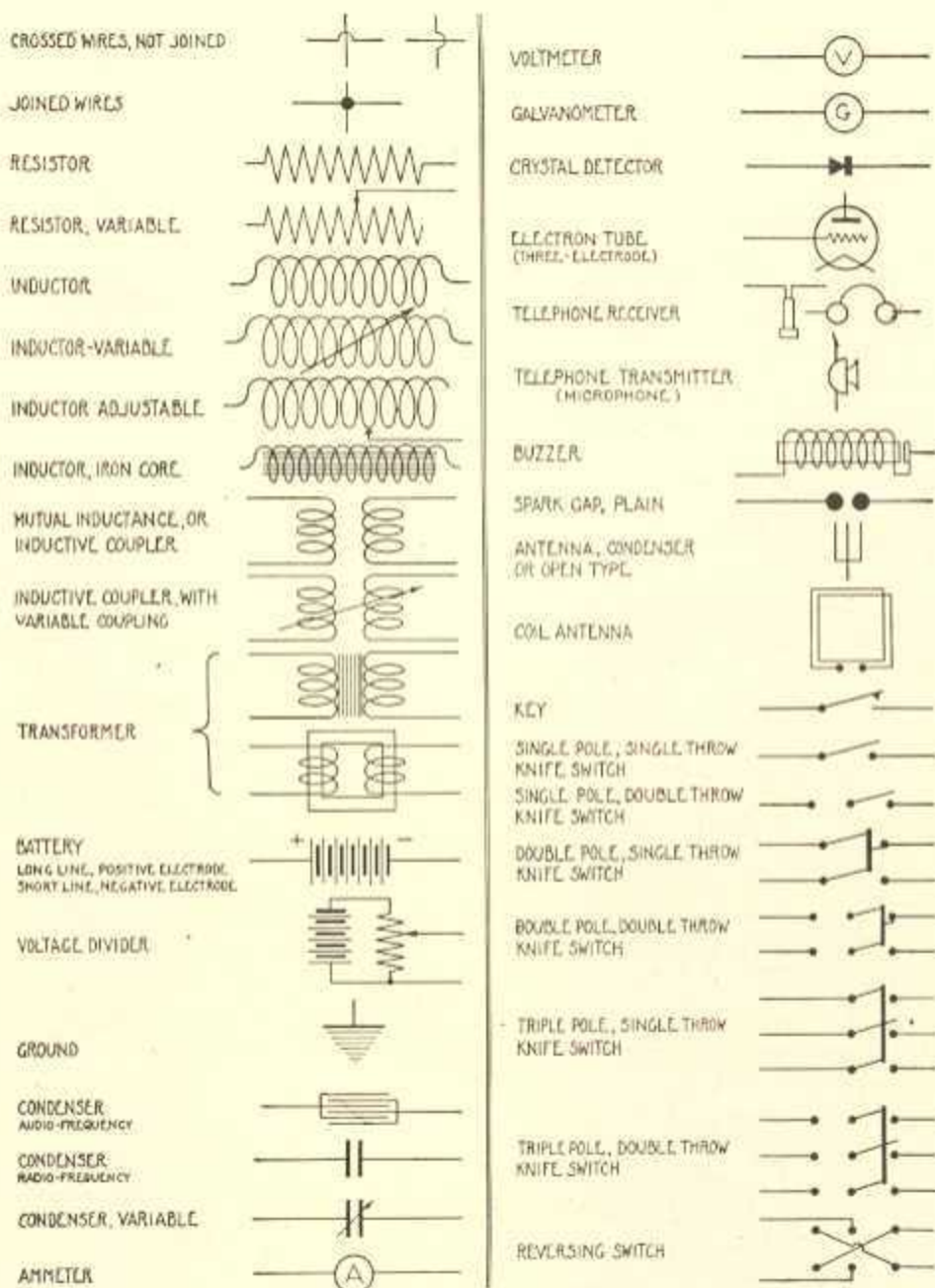

Fig. 10.—Symbols Used in Radio.



# 10-DAY TRIAL

OF THE BEST-PERFORMING  
LOW-PRICED, ALL CHANNEL  
ANTENNA ON THE MARKET!

THE FRINGE AREA

**B** *Butterfly*  
TRADE-MARK

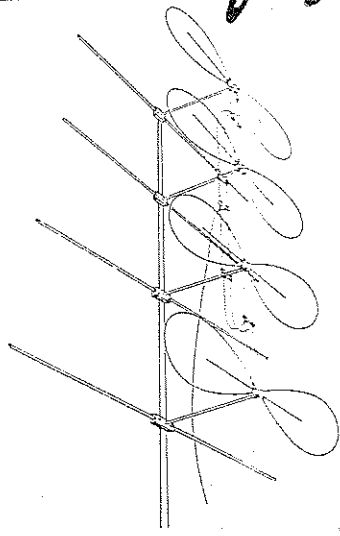

You can enjoy perfect long-range television reception for 10 days with a Fringe Area Butterfly — and it won't cost you a cent for its use.

To acquaint you with this outstanding new all-channel antenna, Tel-a-Ray will send you a Fringe Area Butterfly you can use for 10 days.

If you want to keep the Butterfly after 10 days, you may do so at a price of only \$29.95 (list price) for the four-bay array shown above. If not, send it right back.

Your only cost for using this matchless, long-range, all-channel antenna for 10 days is the shipping charge.

Give your family or customer TV reception at its best. Try a Butterfly! It's a Tel-a-Ray exclusive.

**TEL-A-RAY**  
ENTERPRISES, INC.

# DX CRYSTAL RADIO RECEIVER

By JOSEPH AMAROSE

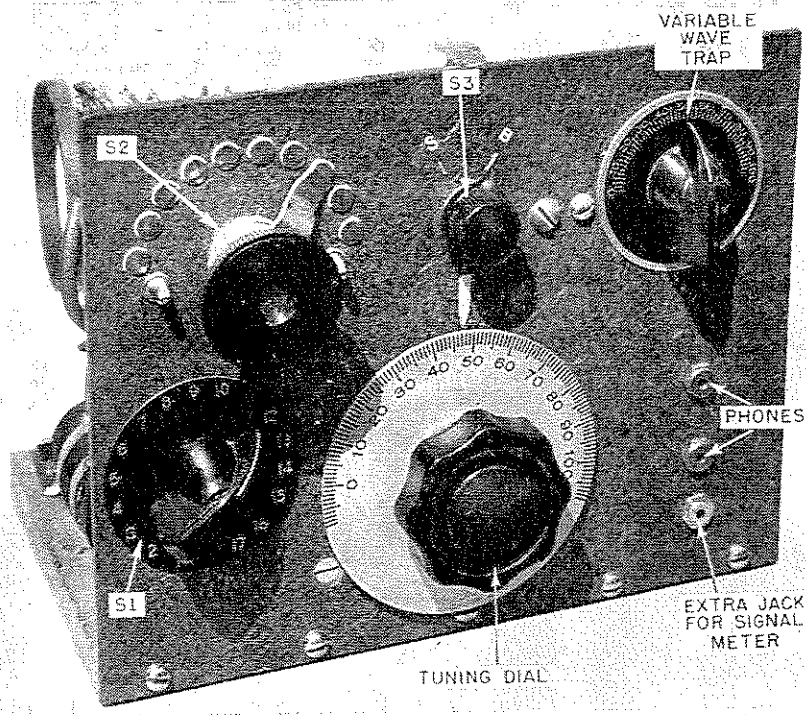
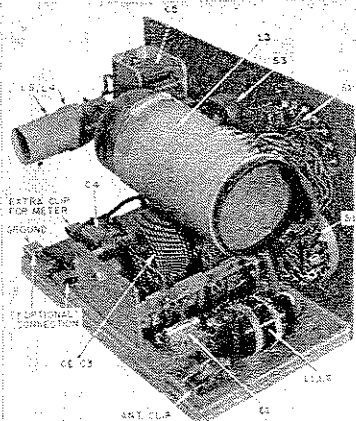

CRYSTAL radio fans follow a pattern. They search everlastingly for a newer, better circuit that will excel their previous best effort. They want better volume, greater selectivity, higher sensitivity. Everlastingly, too, they must compromise, for no such optimum state can be achieved. Occasionally, an experimenter does find a circuit that is outstanding. Such is the hookup shown. No novelty is claimed, however; basically the circuit is old—only a few embellishments have been added. Nor must the reader expect that this receiver combines all the desired characteristics. What the writer (who has spent some 30 years testing and building the latest crystal "super-doopers") does promise is an unusual, versatile receiver that has consistently given fine results.

All last winter (in Virginia) this receiver tuned in stations from Canada to Cuba and from the Atlantic to the state of Utah, sometimes as early as 8 pm. Transmitters in Atlanta, Louisville, Chicago, Detroit, New York, New

Orleans and Cleveland were most frequently logged. Even on the hottest summer nights, dx came in with impressive regularity.

No less impressive is the selectivity of this rig. All six of the Richmond locals are received clearly with no annoying hash or cross-talk. And three of these stations are only 40 kc apart! Worse still, one is a weak sister between two strong ones. Yet this set gets all with ease. With proper co-ordination of controls all locals (from 910 to 1480 kc) can be tuned in with just the one main tuning dial. Tested in Baltimore by M. M. Schuman, another old-timer (who built this set), the receiver tuned in all eight locals clearly there, plus the more distant WTOP in Washington, D. C.

Volume on the locals is high. Richmond's WRNL, 5,000-watt transmitter, five miles away, operates a magnetic speaker loud enough to be heard clearly 15 feet from the reproducer. It doesn't shake the rafters but every word of speech is intelligible at that distance.



How are these results achieved? First and foremost, for good dx, the antenna system should be of the best. A 125-foot aerial was used, 31 feet high, with the lead-in taken from the far end; this proved better than the usual "L" type. Total antenna wire to the set was 260 feet. Shorter aerials are O.K., if high. The fixed antenna wave trap, L1, L2 and C1, is to be used only when two strong stations interfere. Set C1 so it confines the most troublesome station. For dx work, eliminate this trap entirely! Sensitivity is higher.

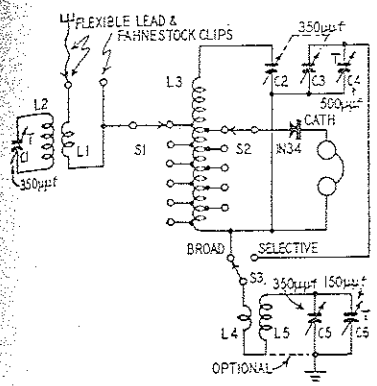

**PARTS LIST**

- C1—350-μf trimmer.
  - C2, C3—2-gang 350-μf variable capacitors.
  - C4—500-μf trimmer.
  - C5—350-μf variable capacitor.
  - C6—150-μf trimmer.
  - S1—7-point switch.
  - S2—10-point switch, or 10 switch points and lever.
  - S3—S.p.d.t. panel switch.
- Other materials needed are coils as given in the table, a crystal, a pair of sensitive phones and the necessary panel, breadboard, hardware, etc.

The main tuning coil, L3, is an MRL (Modern Radio Laboratories, 1181 Valota Drive, Redwood City, Calif.) "low-loss" type. The constructor can make his own by winding 90 turns of No. 22 double-cotton-covered wire on a 2-inch plastic coil form 4 inches long (actual winding is 3 inches). Brush on a layer of very thin coil cement to make it stick to the coil and tap both antenna and secondary sides. Tap the antenna side every three turns from the 3rd to the 51st, and tap the secondary every five turns from the 5th to the 50th. Lift the turns with an ice pick to solder.

A standard 2-gang capacitor is used for C2 and C3, with a 500-μf trimmer across the second section, for hand-spreading on high frequency end. Adjust this trimmer, C4, for best volume on a 1000 kc station.

Switch 1 selects the proper antenna primary-coil tap. Switch 2 is used to match the impedance of the crystal. Tune in all locals, select the setting that gives best selectivity with good volume, and *leave set*. From ground end switch 3 provides a choice between peak sensitivity and high selectivity.

In the variable trap, L4, L5 and C5, a Carron S-645 coil is used. The primary, secondary and variable capacitor are series hooked. An "optional connection" is shown. If used, it makes a conventional wave trap of the section. Not used, another tunable circuit is provided, acting like a series-tuned loading coil and capacitor. With this arrangement, tuning is better.

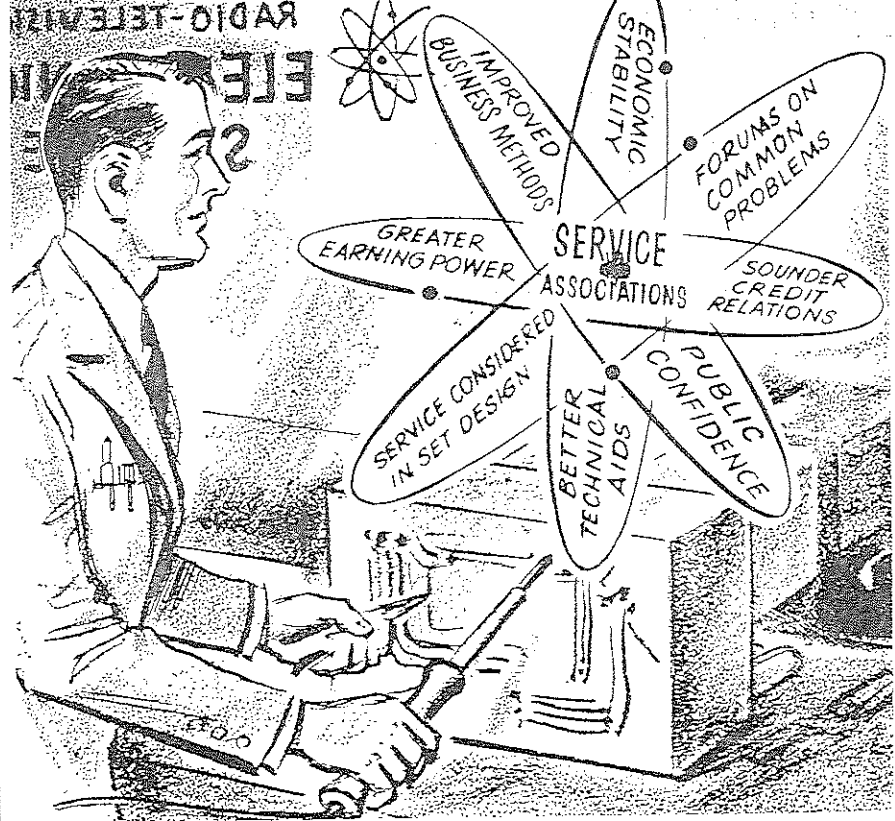

## THE MODERN ELECTRONIC TECHNICIAN HAS A NEW VIEWPOINT!

A changing attitude on the part of the radio and television service technician is the thing that is pulling the electronic service profession out of the doldrums. He is learning that he cannot call himself a success, as an individual, until he can look around and see other technicians who have assets he can admire or compare with his own. As long as there are too many in his profession operating without scruples, and trying to get along under a "hand to mouth" economic operation without adequate testing instruments and other technical aids, there is not much to measure one's success by.

His interest and attendance at the local service association meeting shows that the modern Electronic Technician is beginning to look beyond the "tip of his soldering iron." Through these associations, he is rapidly gaining recognition, not only in his own community, but also in the vast electronic industry, as being an essential link between the manufacturer and consumer.

In addition to getting valuable technical "know-how" from non-commercial sponsored lectures and demonstrations, he is finding out how to make his business bring a fair return on his rather large investment in training, experience,

and testing instruments. He is also learning how to be fair to both his customers and himself by keeping his "know-how" and test equipment up-to-date and not resorting to price cutting for his service in diagnosing trouble.

As technicians gain that feeling of mutual respect and esteem among themselves by regarding each other as business associates instead of raw competition, their most valuable asset—technical "know-how"—will no longer be obscured. The technician's interest in matters which affect his economic welfare will lead him and the entire service industry to greater economic stability.

The time and money you devote to your service organization is not an expense—it is an investment in your future that will be paid back many, many times.

Our 25th Year

# SUPREME

Testing Instruments

"SUPREME BY COMPARISON"

TUBE TESTERS • SIGNAL GENERATORS  
PANEL METERS • MULTI-METERS  
OSCILLOSCOPES

Supreme, Inc. Greenwood 2, Mississippi



# PHOTOFACT USERS TELL THE EXPERT WAY TO TACKLE ANY TV-RADIO SERVICE JOB

here's what you do:

**1**

Determine the make and model number of the set on your bench. Use your PF INDEX to find the applicable PHOTOFACT Folder—takes just 60 seconds.



**2**

Reach into your PHOTOFACT library for the proper Folder. You're ready for time-saving, work-saving, expert service action.



**3**

**YOU HAVE YOUR HANDS ON THE  
ONE TOOL YOU'LL USE ON EVERY JOB**

Here's what you find in PHOTOFACT Folders: A uniform, consistent presentation of *complete* service data, *accurate* because it's based on actual analysis of the production receiver. And here are the exclusive features—Standard Notation Schematics with voltages and wave forms right on the diagrams; chassis view photos, top and bottom, with all parts and relationships shown, all alignment points given, all parts identified; tube placement diagrams, top and bottom, all tubes and functions indicated, even socket pin locations shown, including fuse location guide and rating; tube check chart showing common troubles and tubes responsible; complete alignment instructions, including oscilloscope patterns; resistance measurements taken at every tube socket; separate photos of TV tuner, showing all parts locations and alignment points; photos of cabinet showing service controls; complete disassembly instructions; complete parts lists, each part identified by circuit symbol and keyed to schematics and photos—showing ratings, manufacturer's original part number and proper replacements available from 29 leading components manufacturers—plus—dial cord stringing instructions; special service instructions (such as horizontal sweep circuit adjustments, etc.)—everything you have a right to expect in the world's finest TV-Radio service data . . .

**4**

**NOW HERE'S HOW YOU  
SAVE TIME AND EARN MORE**

You're ready to tackle the job—any job—because you have *all* the answers *instantly* at your finger tips in PHOTOFACT. Here are the *practical* ways it works for you: Suspect a tube? Diagnose and replace the defective tube in seconds



—the tube location chart shows you which one and where. Operating voltages correct? The exact answers are right on the schematic—available at a glance. Need fuse replacement? The answer's right on the tube location guide. Defective component? There's the *right* replacement in the parts list. For these and a hundred other problems, PHOTOFACT provides the *instant, correct* solution. That's why the experts use PHOTOFACT—the practical way to *save time and earn more.*

Yes, your PHOTOFACT Service Data is the

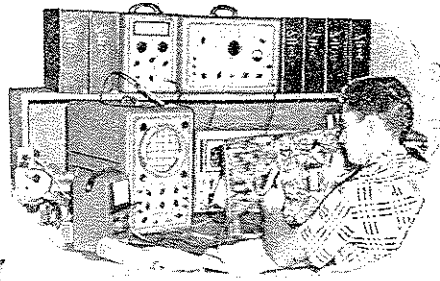

if you're not using the Expert Way—  
we'll prove you'll save time and earn  
more with PHOTOFACT service data

**FREE SERVICE TECHNICIANS  
HERE'S OUR OFFER:**

We'll send you any Photofact Folder listed in the "PF INDEX and Technical Digest." If you haven't an Index, get a Free copy from your local Photofact distributor or write us for it today. To obtain Free Folder, be sure to state Photofact Set and Folder Number exactly as shown in the Index.

NOW—learn for yourself how PHOTOFACT makes your TV and Radio repair work *quicker, easier, more profitable.* We want you to get and use an actual PHOTOFACT Folder. We want you to know why over 35,000 expert service technicians count on this invaluable data daily—count on it for *successful, profitable* business. Get your FREE Folder now. Examine, compare. Then try the Expert Way on your very next job. You'll discover why you can't afford to be without PHOTOFACT!

NOTE: Our FREE Folder offer is limited to Service Technicians only. Attach coupon to your letterhead or business card, and mention your jobber's name. Experimenters and others may obtain the Photofact Folder by remitting amount shown below.

## HOWARD W. SAMS & CO., INC.

HOWARD W. SAMS & CO., INC.  
2205 E. 46th St., Indianapolis 5, Ind.

I am a Service Technician. Send me Free Folder No. . . . . which appears in Photofact Set No. . . . . (as listed in the PF Index).

I am an Experimenter. Enclosed \$ . . . . . Send Folder No. . . . . which appears in Photofact Set No. . . . . (TV—\$1.00. AM/FM—50c. Record Changer or Communications Receiver—75c).

Name . . . . .

Address . . . . .

City . . . . . Zone . . . . . State . . . . .

**EASY  
PAY**

PAY AS YOU EARN! Ask your distributor about this desirable plan. Only \$18.39 puts the entire profit-boosting Photofact

## Construction

The ground for this set was the pipe in a well. This makes the best possible ground connection; a signal meter showed almost twice as much signal strength as with other grounds. The urban dweller should use *cold water* pipes, with the wire attached close to the earth. Additional grounds also boost signal strength and are recommended.

### Operating the set

The settings obviously will differ in each locality, depending upon the frequencies employed by the local transmitters. Individual experiment is necessary to determine optimum settings of controls. Generally, for dx work, eliminate the antenna wave trap, throw S3 to the BROAD position, and do not make the "optional connection." For best selectivity, use the antenna wave trap, move S3 to the SELECTIVE position, and hook up the OPTIONAL CONNECTION. With the connection closed, tune the trimmer C6 to loudest volume on a 1000-ke station. This completes all adjustments on this set.

In constructing the receiver, it is important to position both wave-trap coils as far as possible from the main tuning coil. The selectivity will be poor if their magnetic fields are allowed to affect each other.

A word about "signal meters." The serious dx fan will do well to consider using a sensitive microammeter across the phone posts, to determine peak signal strength. All the unusual results achieved by this receiver are due to the use of such a meter. Many months were spent making changes until the present circuit arrangement was arrived at; more time was spent in determining the best aerial and ground arrangements. All the optimum conditions were quickly revealed by the meter readings. By the cut-and-try aural method usually used, optimum conditions could not be very readily determined. These meters are still available at prices under \$10 in surplus houses. A 200-microampere instrument is ideal. Especially useful is this device in picking out the most sensitive detector; some crystals give twice as much output as others, and a meter can spot your best one in an instant. For weak stations and dx work, this is most important. The value of such an instrument in helping to get distance cannot be overemphasized.

Finally, super-efficient as the aforementioned receiver might be, no extravagant claim is made for it. All the writer can say is, that, of the large crop of radios tested through the years, this one stands head and shoulders above the crowd. Made according to specifications, it should provide the hobbyist with no end of pleasure and entertainment.

### COIL TABLE

L1—25 turns No. 30 enameled-wire wound over L2.  
L2—125 turns No. 30 enameled wire on 1-inch form.

(A low-impedance antenna coil will work well here. The constructor used a Carron S-645.)

L3—90 turns double-cotton-covered wire close-wound on 2-inch coil form.  
L4—Low impedance primary of Carron S-645



# Crystal detectors and how they work

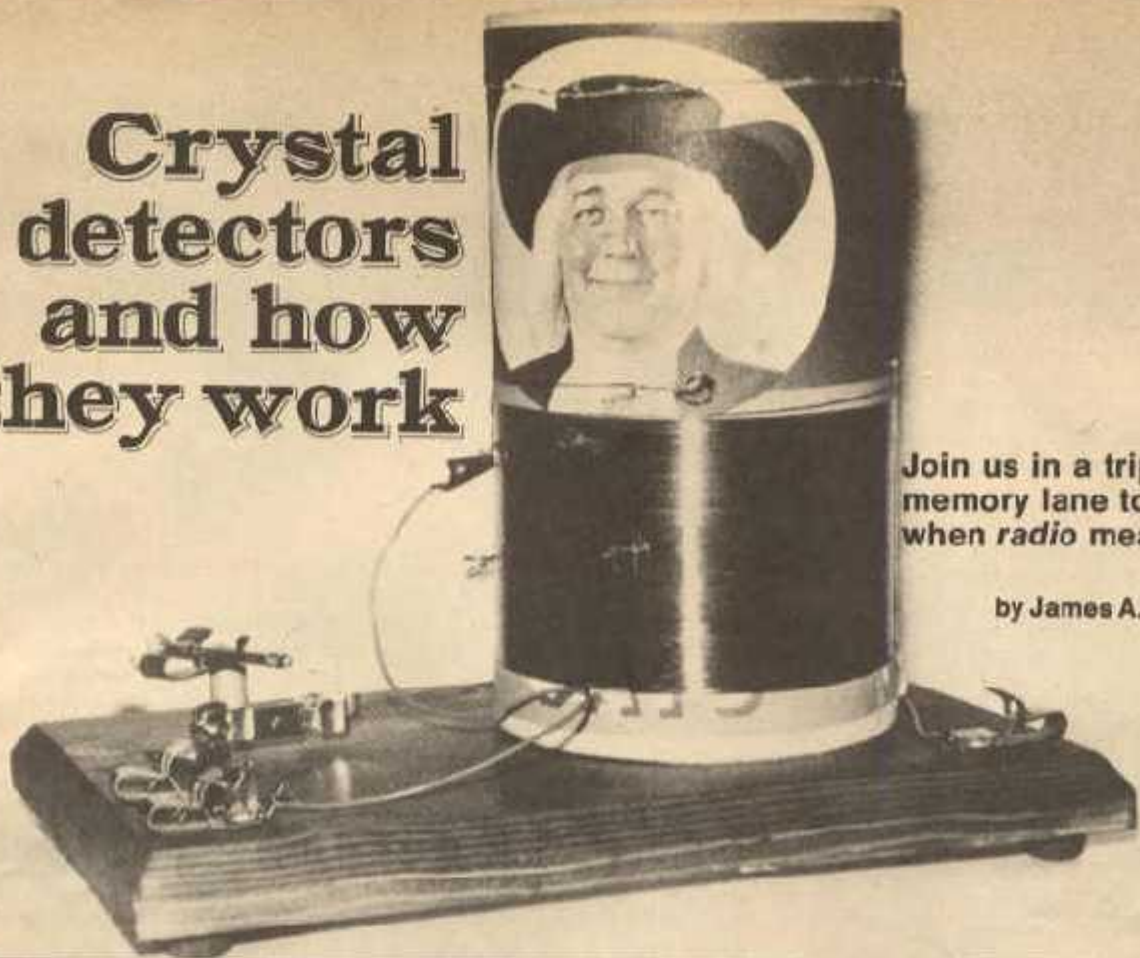

Join us in a trip down memory lane to the time when *radio* meant *crystal*

by James A. Fred

**R**ADIO WOULD NOT BE POSSIBLE without a means of detecting the signals. Detection of a signal refers to the separation of the audible signal from the radio frequency carrier signal. Over the years since 1873, many kinds of detectors have been used. The first really sensitive and stable detector was the mineral detector of Dr. Greenleaf Whitier Pickard. Utilizing the research of Professor Braun which showed the "unilateral" conductivity of certain minerals such as Pyrite and Galena, Dr. Pickard developed the crystal detector. During the developmental process, Pickard found over 250 different minerals that would detect radio signals when used in conjunction with metal contacts. He actually tested over 31,000 combinations, finding many hundreds of useful pairings.

**Early Development.** The crystal detector developed by Dr. Pickard between 1902 and 1906 was the first truly sensitive and fairly stable detector. The crystal detector was more sensitive than the Fleming Valve (diode) and even the deForest Audion (triode). As testimony to that fact, many radio operators kept a crystal detector on standby for their vacuum tube receivers. The one drawback to any detector, including the crystal detector, is that they do not amplify signals, but merely detect the signals received.

**Ups and Downs.** This lack of amplification requires that every possible step be taken to provide the highest level of signal to the receiver. The antenna gathers in the radio signals and the higher it is and the longer it is (to a point) the stronger the signal is. Of course in this day and age there has to be a limit to the height and length of the antenna. These limits will vary with where you live and how far you are from radio stations. For use with the crystal radio we are about to describe, your antenna should be from 10 to 25-foot high, and from 50 to 100-foot long.

Lack of caution in erecting antennas has caused some fatal accidents, so we urge that you use care when making your installation. No antenna should cross, go under, or even be erected near power lines, or even telephone lines. Keep your antenna in the clear. Not only will this prevent an accident, but it will help avoid picking up power line noises that could drown out the radio signals.

A good ground is next in importance, since the ground completes the antenna circuit. Usually a connection to a cold water pipe is considered an acceptable ground, but today this is not always true. The pipe could have a plastic section, or could be separated from the earth by a meter or other device. A better ground can be obtained by driv-

ing a copper-plated rod at least six-feet long into moist soil. Try to avoid sandy or dry soil, as it makes a poor ground. Don't drive the rod under the eaves of the house, because the rain will not moisten the ground there. The old-time radio experimenters sprinkled a few crystals of copper sulphate around the upper section of the ground rod. The copper salts would improve the soil conditions and make a better ground. Use a good ground clamp to attach your ground lead-in or better yet solder it to the ground rod.

**The Human Connection.** With further respect to the fact that crystal detectors do not amplify, and that every possible way to improve the strength of the received signal must be taken advantage of, the need for a set of the most sensitive headphones available must be recognized. You cannot use crystal headphones or the low-impedance (4 to 16-ohms) dynamic phones found on today's market. Most of the mail order radio parts catalogs will list 2000-ohm headphones, which are the ones you should buy. If you can find 4000 to 8000-ohm units, you will hear an even stronger signal on your crystal radio.

While the preceding tells us what to do to receive the best signal possible, we have not discussed the crystal detector itself. If a crystal detector is examined, it will be found to be merely a



# Crystal detectors

stand that holds the mineral in place with electrical contacts probing the mineral. Most minerals are mounted in a metal cup filled with a low melting-point metal, called Woods metal. The low melting-point prevents damage to the mineral crystal, which could cause it to lose its sensitivity. The adjustable electrical contact probing the mineral is called a "Cat Whisker," since it is a fine, springy wire. These two contacts to the mineral form a junction that permits electrical current to flow in one direction, or, as Pickard called it, "unilateral conductivity." This is a form of rectifier diode, and its action detects the audible signal which operates the headphones and permits us to hear the program material.

Now that we have all the necessary background for building and using crystal detectors, let's build a simple Cat Whisker crystal set which requires no parts beyond the wire and crystal, which we in jest have called the "No Parts Crystal Set."

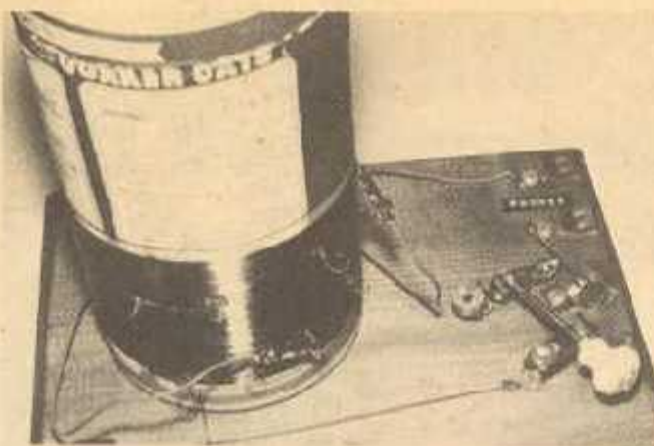

You can't make a simpler, or less expensive BCB receiver than this one. Even the coil winding isn't terribly critical, but the value we selected gave the best result.

**Construction.** You can build your crystal receiver on a piece of pine board, just as the oldtimers did. If you follow our layout, you won't need any fancy hardware, and in fact, you can use the exact same materials which were used years ago to build the first sets. Don't laugh! They actually worked, as you will see.

First, mount 4 terminals. You can use Fahnestock clips, or make your own with four wood screws and washers on them. Run the antenna wire, etc. between the washers and tighten the screws. Build your crystal detector stand at the right-hand side of the board. Use the small battery clip to hold the mounted crystal, and attach this battery clip

to the board with a small angle bracket. Connect this to one headphone terminal. Take a 3-inch piece of wire, strip away the insulation, and mount it about 1/2-inch from the mounted crystal. Form a cat whisker with this wire so that it touches the surface of the crystal. If you want to go first-class, you can buy a complete, mounted detector, but this is not necessary. Connect this catwhisker to the ground terminal on your board.

Wind your coil on the empty oatmeal box, making a tap every 10 turns. You will need a total of 120 turns to cover the broadcast band, since this set does

*(Continued on page 118)*

ANTENNA

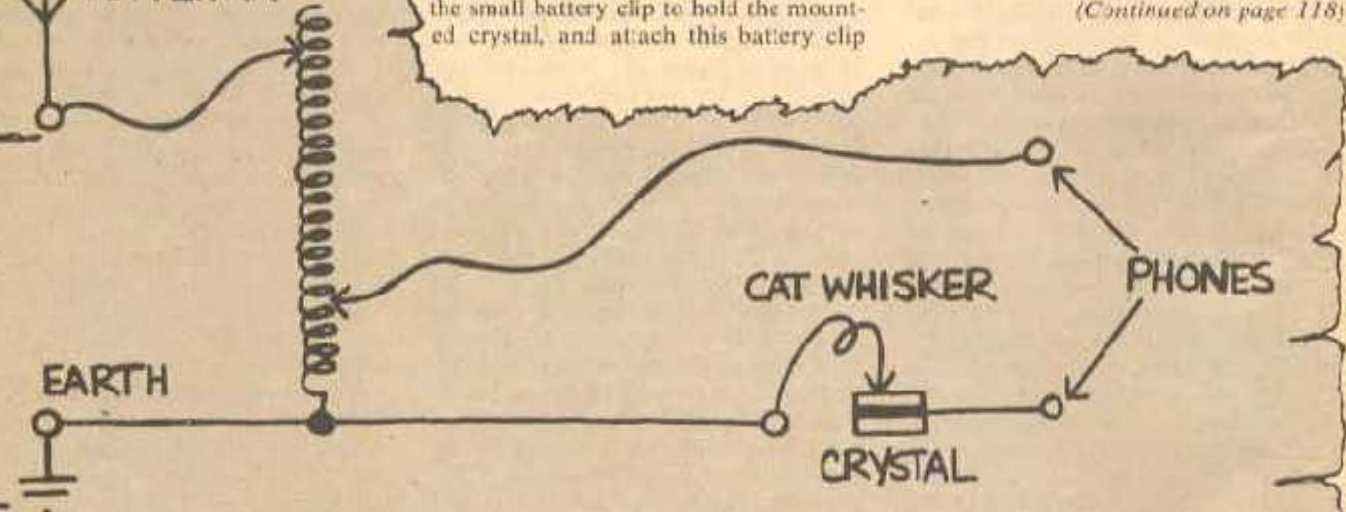

## Materials

One Oatmeal Box (empty)

Four Fahnestock Clips

One Mounted Crystal

One Spring Clip (to hold crystal)

Two Small Alligator Clips

One Cat Whisker and Holder

[not from a neighbor's cat]

Hookup Wire, Solder, Wooden Base

130 feet of #22 Enameled Wire

This "authentic" schematic was found in Grandfather's trunk in the attic, wrapped around a stack of Grandmother's love letters. Grams was never too much of a sentimentalist anyway, except when it came to radio. For good, clean fun in his day, radio couldn't be beat.



## Crystal Detectors

(Continued from page 84)

do not use a variable capacitor for tuning. You make the taps while winding the coil, by twisting the wire, at the proper turn, to form a small loop of about  $\frac{1}{4}$  to  $\frac{1}{2}$ -inch in diameter. Wind your coil so that connections can be made to the wire at each end of the coil.

Now, use a little cement on the coil around each tap to strengthen it. When the cement is dry, use fine sand paper to clean away the insulation, so a bare copper loop will be exposed. Fasten your coil form to the board with cement, or with thumb tacks thru the bottom of the box. Connect the wire at the bottom of the coil to the ground lead that runs between the cat whisker and the ground terminal on the board.

Next, prepare two short lengths of wire (about 10-inches long). Solder one end of one wire to the antenna terminal and solder a small alligator clip to the other end. Take the other piece of wire and solder it to the headphone terminal, and then solder the other alligator clip to the other end of this wire.

**Operation.** Now your set is finished and the fun begins. Connect an antenna

and ground to the terminals, and connect your headphones to the other two terminals. You will use the two small alligator clips to tune your set. Clip the one from the headphone terminal to a tap near the upper end of the coil, and the one from the antenna terminal to a tap near the lower end of the coil. Move the end of the cat whisker over the galena crystal until you find a sensitive spot where you can hear a station. Now move the alligator clips up and down the coil to get maximum volume. You will be surprised at the clarity and tone of the signal. You see, a crystal detector doesn't amplify, so it doesn't distort the signal.

This is truly a basic crystal set. It has but one tuned circuit, therefore it is *not* selective. In fact, if you live near several strong broadcast stations, you may hear more than one signal at a time. While not intended to be the centerpiece of your home's sound system, you have learned, by building it, crystal theory and some of the history of radio development during the early part of the century.

As you listen to your crystal receiver, you will get a feeling of satisfaction akin to the thrill the experimenter of the early 1920's got when he built his first crystal set.



# Construction and Operation of a Simple Homemade Radio Receiving Outfit

The 1922 Bureau of Standards publication, *Construction and Operation of a Simple Homemade Radio Receiving Outfit* [1], is perhaps the best-known of a series of publications on radio intended for the general public at a time when the embryonic radio industry in the U.S. was undergoing exponential growth.

While there were a number of earlier experiments with radio broadcasts to the general public, most historians consider the late fall of 1920 to be the beginning of radio broadcasting for entertainment purposes. Pittsburgh, PA, station KDKA, owned by Westinghouse, received its license from the Department of Commerce just in time to broadcast the Harding-Cox presidential election returns. In today's world where instant global communications are commonplace, it is difficult to appreciate the excitement that this event generated.

News of the new development spread rapidly, and interest in radio soared. By the end of 1921, new broadcasting stations were springing up all over the country. Radios were selling faster than companies could manufacture them. The demand for information on this new technology was almost insatiable. The Radio Section of the Bureau of Standards provided measurement know-how to the burgeoning radio industry as well as general information on the new technology to the public. Letters to the Bureau seeking information on radio technology began as a trickle, and then soon became a flood. Answering them became a burden.

Circular 120, published in April 1922, began: "Frequent inquiries are received at the Bureau of Standards for information regarding the construction of a simple receiving set which any person can construct in the home from materials which can be easily secured. This publication has been prepared to meet these inquiries." The circular also noted that the Bureau was cooperating with the Bureau of Markets and Crop Estimates of the Department of Agriculture. In the early days of radio, broadcasts to farmers of crop price reports were an important public service.

In 1921 factory-made radios were very expensive. Many of them cost more than \$2000 in today's dollars, and less affluent families could not afford to have one. When the Bureau published this circular (which sold for only five cents) on how to build a simple crystal radio at home, it was an instant success. Thousands of orders

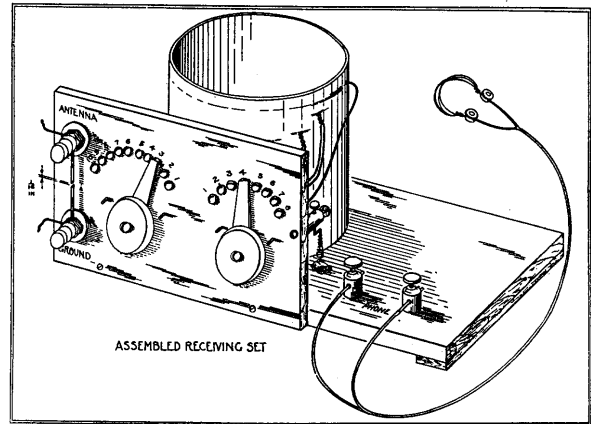

Fig 1. The crystal radio described in Circular 120.

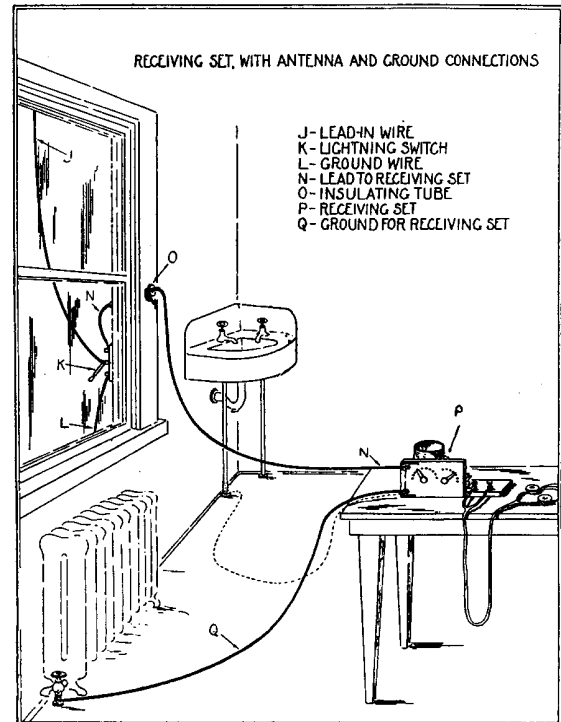

Fig. 2. Diagram showing the antenna and ground connections to the radio.



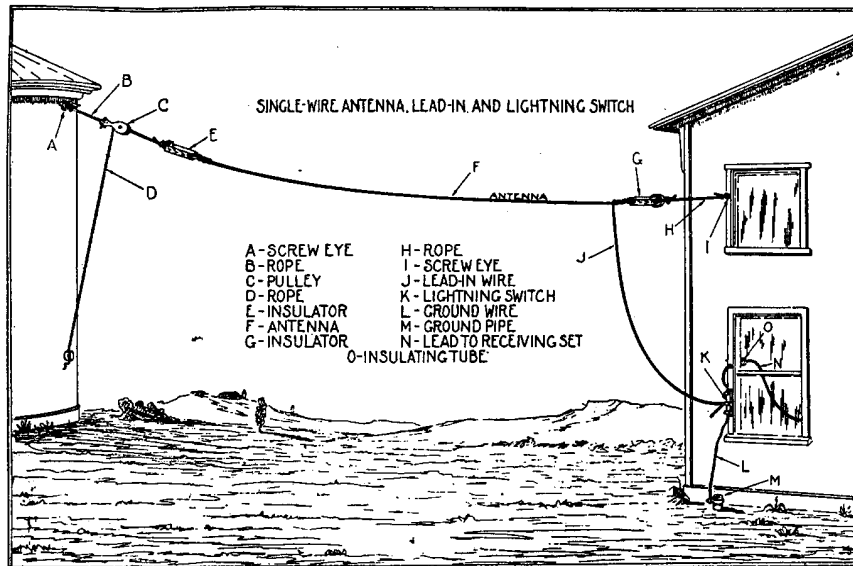

Fig. 3. Details of the outdoor antenna recommended for use with the crystal radio.

flowed in from every state. The circular showed how almost any family having a family member handy with simple tools could make a radio. The circular states “Satisfactory results have been obtained from sets constructed according to these instructions by persons having no previous experience with radio.” The authors stated that the cost of the materials for the radio and associated headphones and antenna system should not exceed \$10.

Newspapers around the country urged readers interested in radio to order a copy, and in many cases they reprinted the entire article. Even today, antique radio collectors searching attics and basements often come across dusty home-built crystal radio sets that were obviously constructed using the Bureau’s plans. No doubt the remarkably rapid growth of the radio industry in the U.S. during the 1920s (analogous to the growth in Internet-related businesses today) was aided considerably by information provided to the public by the Bureau, such as this circular and the other items noted in the bibliography [2-6].

Circular 120 proved such a success that the Bureau published a number of other circulars on radio technology intended for the general public, as noted in the bibliography. All were popular. In some cases, commercial radio manufacturers copied the circuits proposed by the Bureau. During the same era, other radio publications of the Bureau captured public attention as well, though perhaps in smaller quantities than Circular 120. *Radio Instruments and Measurements* [7], Circular 74, published first in 1918 with a second edition published in 1924, became a best seller in the

post-WW I era. Its principal authors were most likely J. H. Dellinger, J. M. Miller, F. W. Grover, and G.C. Southworth. The authors of Circular 120 are not stated, but some of those same individuals likely contributed to it. J. Howard Dellinger’s story is particularly interesting. He came to the Bureau in 1907 as a laboratory assistant at \$900 per year, and retired as Chief of the Central Radio Propagation Laboratory in 1948. He headed the Radio Section for much of its existence. Appendix D of Reference [9] is a biography of Dellinger.

*The Principles Underlying Radio Communication* [8], Signal Corps Radio Communication Pamphlet No. 40, published in 1919 and issued in a revised edition in 1922, is another interesting example of a popular radio book. Written by the Bureau of Standards for training Army Signal Corps officers, it was an expanded and updated version of Circular 74, noted above, but was also widely used by college students and others studying radio. In spite of the “pamphlet” designation, it was actually a 600-page book. Thomas Edison said “. . . This is the greatest book on this subject that I have ever read, and I want to congratulate you and your Bureau on its production.”

While the general public was interested in radio information for the lay person, the fledgling radio industry needed in-depth technical assistance from the Bureau, which it got. The Bureau helped radio manufacturers make better measurements for quantities such as resistance, capacitance, voltage, and frequency. Results of Bureau research on antennas and radio wave propagation, direction finders, vacuum tube characteristics, and testing were eagerly utilized by major



companies such as General Electric, Westinghouse, Western Electric, and RCA, as well as by a myriad of small radio companies no longer in existence. At the same time that the Bureau was providing information to people constructing radios on their kitchen tables, Radio Section staff members were presenting technical papers on radio at conferences and in journals such as the *Proceedings of the Institute of Radio Engineers*. A good example of the latter is the classic work by John Miller, who discovered and explained “the Miller effect”—a feedback effect in triode vacuum tubes that limited their ability to amplify at radio frequencies [9].

Circular 120 described in detail not only the crystal radio itself but also how to construct an antenna and ground system. To minimize the cost, the circular suggested winding the tuning coil on a discarded cylindrical oatmeal box. For years afterwards, home experimenters used oatmeal boxes as coil forms for homemade radios. The crystal radio did not require batteries, but it did require the user to purchase a commercially made set of headphones (or telephone receivers as they were called in those days), since that accessory was not suitable for home construction.

One can just imagine the thrill of a farm family that had never heard a radio broadcast before trying the new set for the first time, and one of the family members crying out, “Come listen! I am hearing something!” The electronics revolution was underway and the Bureau played a significant part in accelerating the new technology.

*Prepared by Brian Belanger.*

## Bibliography

- [1] *Construction and Operation of a Simple Homemade Radio Receiving Outfit*, Circular of the Bureau of Standards, No. 120, U.S. Government Printing Office, Washington, DC, April 24, 1922.
- [2] *Construction and Operation of a Two-Circuit Radio Receiving Equipment with Crystal Detector*, Circular of the Bureau of Standards, No. 121, U.S. Government Printing Office, Washington, DC, July 17, 1922.
- [3] *Sources of Elementary Radio Information*, Circular of the Bureau of Standards, No. 122, U.S. Government Printing Office, Washington, DC, June 22, 1922. (Updated to second edition, Sept. 12, 1923.)
- [4] *Description and Operation of an Electron-tube Detector Unit for Simple Radio Receiving Outfits*, Circular of the Bureau of Standards, No. 133, U.S. Government Printing Office, Washington, DC, November 10, 1922.
- [5] *Auxiliary Condensers and Loading Coil Used with Simple Homemade Radio Receiving Outfits*, Circular of the Bureau of Standards, No. 137, U.S. Government Printing Office, Washington, DC, Feb. 23, 1923.
- [6] *Description and Operation of an Audio-Frequency Amplifier Unit for Simple Radio Receiving Outfits*, Circular of the Bureau of Standards, No. 141, U.S. Government Printing Office, Washington, DC, March 24, 1923.
- [7] *Radio Instruments and Measurements*, Circular of the Bureau of Standards C74, U.S. Government Printing Office, Washington, DC, 1918. (Second edition published in 1924.)
- [8] *The Principles Underlying Radio Communication*, Signal Corps Radio Communication Pamphlet No. 40, U.S. Government Printing Office, Washington, DC (1919). (Written by Bureau staff members.)
- [9] W. F. Snyder and C. L. Bragaw, *Achievement in Radio: Seventy Years of Radio Science, Technology, Standards, and Measurement at the National Bureau of Standards*, NBS Special Publication 555, National Bureau of Standards, Boulder, CO (1986).



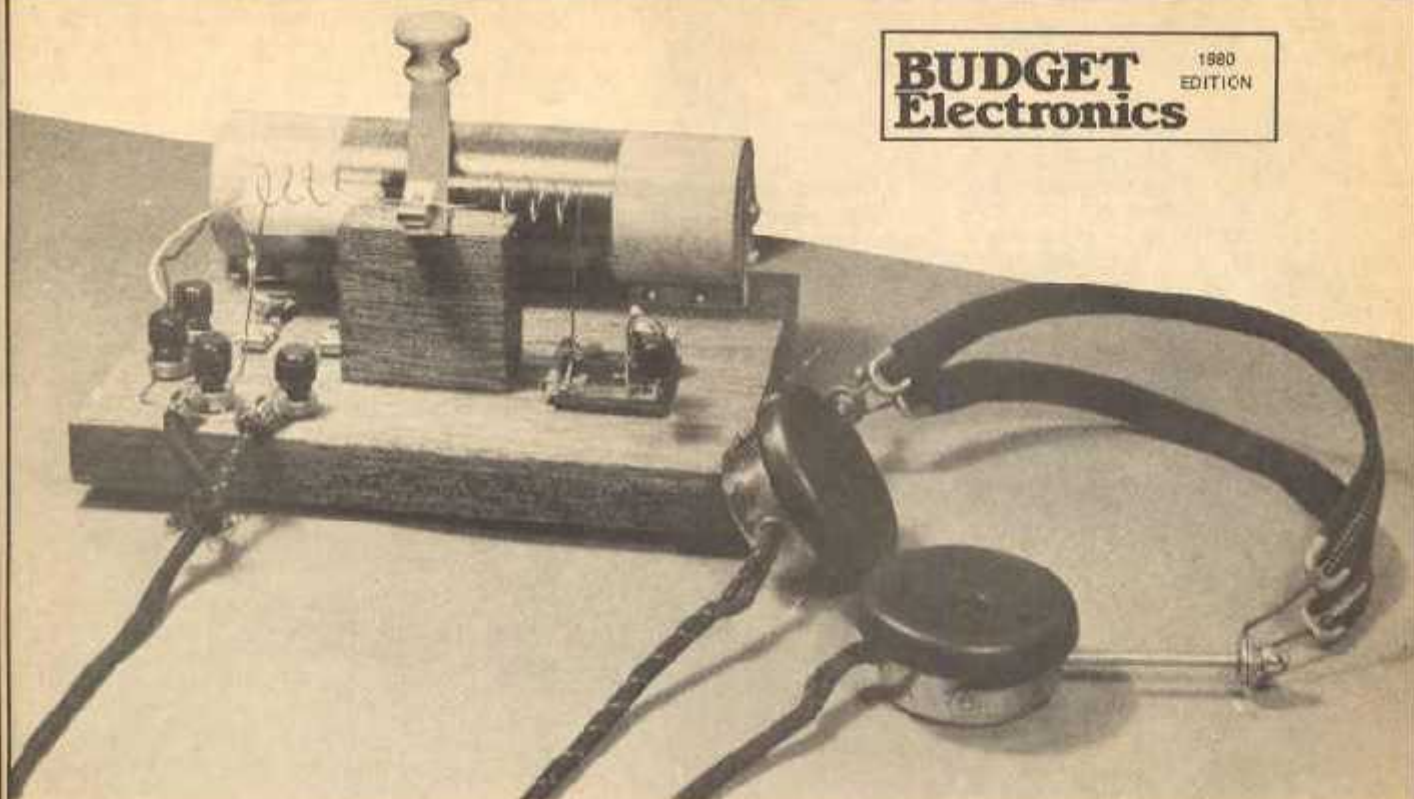

# CLASSIC CRYSTAL

A low-cost crystal set that will enrich any collection.

by George Campbell

**Y**OU CAN RELIVE THOSE EARLY days of broadcasting by building this authentic reproduction of a crystal radio from the early part of this century. This afternoon's project uses the same components, mostly hand-built, that your grandfather used to use, and costs less than \$10 to build.

The heart of this receiver is an authentic crystal detector, using a natural galena crystal and a cat-whisker. It is available by mail order (see parts list for ordering information). The coil and the condenser are also handmade, using original techniques from the early '20s.

**Old-Style Components.** Begin by lay-

ing out the wood base according to the drawing. You may use any wood you choose, as long as it's dry and well-seasoned. Drill 3/32-inch pilot holes for the screws and 5/32-inch holes for the binding posts. Counterdrill the binding post holes 3/4-inch deep with a 1/4-inch bit. Glue the slider support block to the base, then give the entire base two coats of shellac, the original finish for most of those old-time sets.

While the base dries, make the coil and condenser. The coil is wound on 4 inches of a 7-inch section of a rolling pin. Remove the handle from one end and withdraw the iron rod that passes through the rolling pin. Cut the rolling pin to length, and put the nylon bearing from the unused end of the pin in the hole in the 7-inch section.

Drill 1/16-inch holes completely through the wood, 1 1/2 inches from each end. Use the original rod from the pin as an axle, and carefully wind a single, smooth layer of No. 25, coated copper magnet wire between the holes. The coil must be tight, with no overlaps. Pass the wire ends through the pre-drilled holes to anchor the coil, then give it two coats of shellac.

Next, cut the parts of the condenser as shown in the diagram. On a hard surface, stack the strips together, beginning with the Kraft paper, then waxed paper, then foil, waxed paper, foil, waxed paper, and Kraft paper.



The roll-your-own capacitor is made of metal foil and paper—just like the old days.



The crystal/whisker act as a rectifier diode to detect audio from the tuned LC circuit.



# CLASSIC CRYSTAL

The L-shaped ends of the foil should be at opposite ends of the stack, and protrude from opposite sides. Make sure the foil is centered between the layers, then bind the edges of the condenser together up to the foil with masking tape. Roll the bundle up tightly. Cover the completed condenser with masking tape and crush the protruding foil into wire-like leads.

Make the slider from a 1/8-inch by 1/2-inch brass strip, 6 inches long. Round the

corners with a file and drill a 5/32-inch pivot hole, 1 inch from one end and a 3/16-inch hole for the knob at the other. Solder a 3-inch piece of No. 12 bare copper wire to the underside of the slider to make contact with the coil.

**Assembly.** Mount all components on the base, using No. 5 x 1/2 inch brass, round-head wood screws. Place a fiber washer under the tuning slide pivot to reduce friction. Locate the tuning coil so that the holes in the nylon bushings line up with the top holes in the brass L-brackets. Use a No. 8 wood screw here. Attach the rubber feet to the bottom of the base.

Wire the receiver according to the drawing, using No. 20 copper wire. Remove the insulation and shellac from the top of the tuning coil with fine sandpaper, and bend the tuning slide slightly to provide good contact with the bare wire of the coil.

To use your crystal set, connect the antenna-binding post to a good antenna (one side of a TV lead-in works well). The ground post must be connected to a good ground, such as a cold water pipe. The headphones used with this set must be the high impedance type. Normal stereo headphones will not work with this primitive receiver. If you wish, you can attach the center conductor of a shielded cable to binding post J3, the shield to J4, and plug the other end into an amplifier to provide loudspeaker reception and easier listening.

Locate a sensitive spot on the galena crystal by slowly dragging the cat-whisker spring over its surface with the tuning slide centered on the coil. Once a sensitive spot is found, you should hear a local station clearly. Tuning this receiver takes time and patience, so don't give up.

Don't be surprised if you hear more than one station at once. Crystal sets are not very selective. However, careful adjustment of the tuning slide should separate stations reasonably well. And who knows? One day you may even hear a voice from the past.

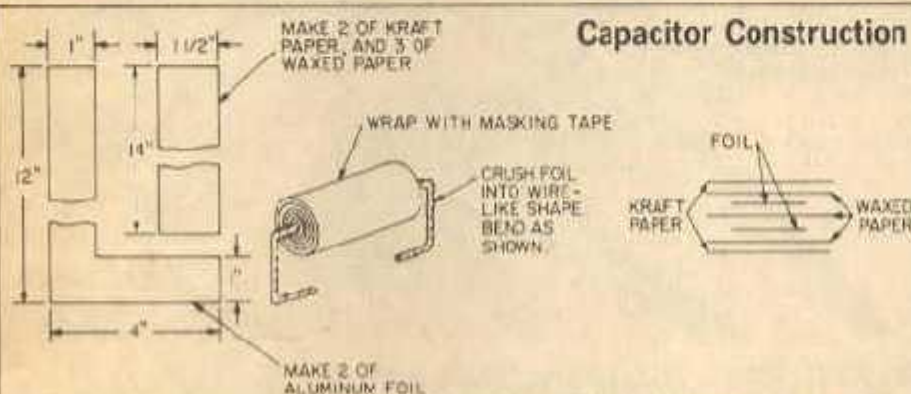

To build the capacitor (C1) cut strips of aluminum foil, kraft paper, and wax paper according to the patterns above. Then interleave the strips as shown above, with the L-shaped ends of foil at opposite ends of the bundle, facing in opposite directions. Bind the edges with masking tape and roll the bundle tightly. Test it with a VOM; if the meter moves and then goes back to infinite resistance then C1 is OK. If not, rebuild C1.

## Parts Placement

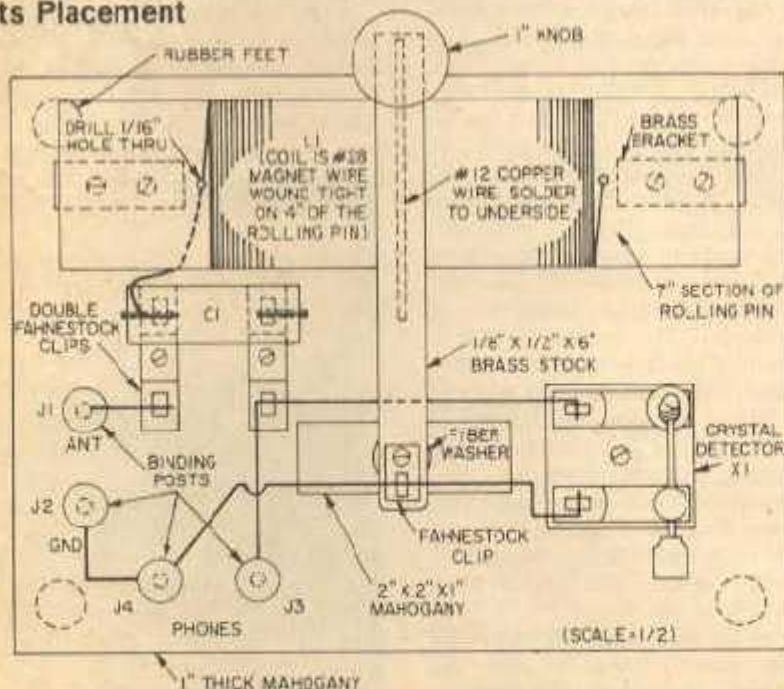

This parts' location diagram shows the relative positions of all the parts. It is drawn to half-scale, so multiply any distance by two to get the full-scale measurements. The wire connections are the bold lines. Wind the coil for four inches along the rolling pin. The non-functional coils on each side of the wiper in the photograph are for decoration.

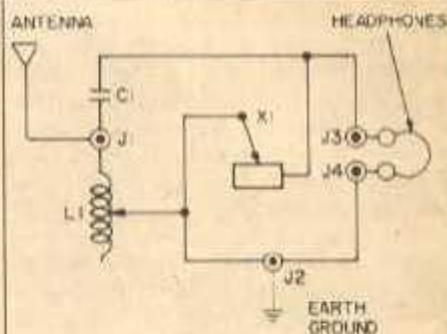

## PARTS LIST FOR CRYSTAL SET REPLICA

- C1—capacitor (see diagram)
- J1, J2, J3, J4—binding posts
- L1—tuning coil (see text and diagram)
- X1—Crystal detector, available from: Johnson Smith Company, 35075 Automation Drive, Mt. Clemens, MI 48043. Order catalog No. 6590, Enclose \$1.95 plus \$0.60 for postage and handling. Allow 3 weeks for delivery.
- Misc.—6- x 8-inch wooden base, 2- x 2- x 1-inch wood slider support block, aluminum foil, wax paper, kraft paper, 150 feet No. 26 coated, copper magnet wire, 3 feet No. 20 copper wire, 3 inches No. 12 copper wire, wooden rolling pin, 2 No. 18 double Fahnestock clips, 1 No. 18 single Fahnestock clip, 1/8- x 1/2- x 6-inch brass strip, fiber washer, rubber feet, wooden knob, two 1 1/2-inch brass "L"-brackets, assorted brass round-head wood screws.



# Cigar Box Radio

**B**ACK in the early days of radio, it was a common sight to see the entire family crowding around and taking their turn at the earphones of the latest marvel of the age—the crystal set radio. It seemed so uncanny how it was possible to get music and voices in the room from afar without the use of wires. With the advent of newer radios the crystal set slowly lost its popularity. However, it still is lots of fun to turn the pages of time back and build a simple crystal set. Anyone with but average workshop skill can easily construct such a set in an evening or two, and, if located about ten miles from a broad-

casting station reception should be good.

The first step is to make the tuning coil inductance that is used in the antenna circuit. Take a piece of  $\frac{3}{4}$  to 1 in. diameter mailing tube or fibre tubing about 6 inches long and closely wind on a single layer of No. 26 to 28 gauge enameled wire. For winding the coil make the simple jig shown in Photo 1. The jig consists of a base board with two L-shaped metal brackets. The coil tube is set between the brackets with a screw holding one end and a piece of  $\frac{1}{8}$  in. steel rod which acts as a handle, imbedded into the other end. Both screw and handle rod are driven into a round piece of wood pressed into the tube for a center core. The wooden center is left in place and later permits mounting the finished coil permanently in the cigar box. The end of the steel rod, which forms the turning handle, is flattened where it is driven into the wood.

The start and finish of the coil are secured from unwinding by drilling a small hole at each end of the tube and passing a loop of the wire through each hole. The coil is then given a coat of thin shellac, as illustrated in Photo 2.

The next job, shown in Photo 3, is to



Winding the coil. Coil tube, with its wooden center core, revolves when the handle is turned.



After the ends of the coil are made secure, apply a thin coat of shellac to the entire surface.



Carefully solder a wire lead to each end of the coil. Use No. 18 or 20 insulated flexible wire.

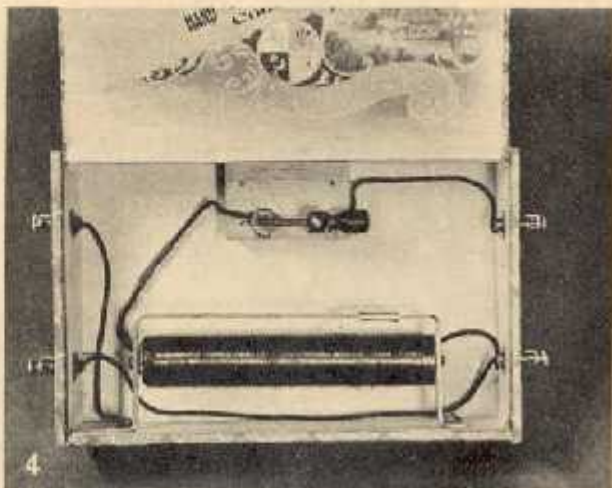

Arrangement of parts within the cigar box. Note the coil mount, slider, and crystal detector.





tical store. At each end of the box binding posts are fitted. The upper one at the left side is for the antenna connection and the lower one for the ground. The right hand terminals are for the phones. The antenna comes in and connects to the brass slider at its bottom foot. The ground connects to one phone terminal and also to one end of the coil. The other end of the coil goes to the crystal and the detector arm to the remaining phone terminal.

solder a piece of No. 18 or 20 insulated flexible wire to the start and finish of the coil to act as leads. Each wire lead is made secure by inserting the end through the hole drilled for the winding ends.

Next mount the coil to the front side of the box with short bolts inserted through a combination support and slider arrangement, as pictured in Photo 4. The support is merely a strip of  $\frac{1}{4} \times \frac{3}{16}$  in. brass bent to fit the coil. The slider, built up from sheet brass, slides freely on the strip. Clean the coil over which the slider rides with fine sandpaper, down to the copper, so a good contact will be made with every turn. Wood screws are used at each end of the coil to hold it in place.

The detector is a common mounted galena crystal and an adjustable arm with a "cat whisker," obtainable from any radio or elec-

For best results a long outside antenna of about 75-100 ft. long is recommended. The earphones should be sensitive and wound to a fairly high resistance, such as 2000 ohms. Adjustment is provided by the sliding contact which varies the tuning inductance. It should be possible to get several local stations on different spots on the coil, but selectivity will be only fair so in some cases interference may be experienced. The detector must be very carefully adjusted to find a sensitive spot by moving the cat whisker around to touch different places on the crystal.

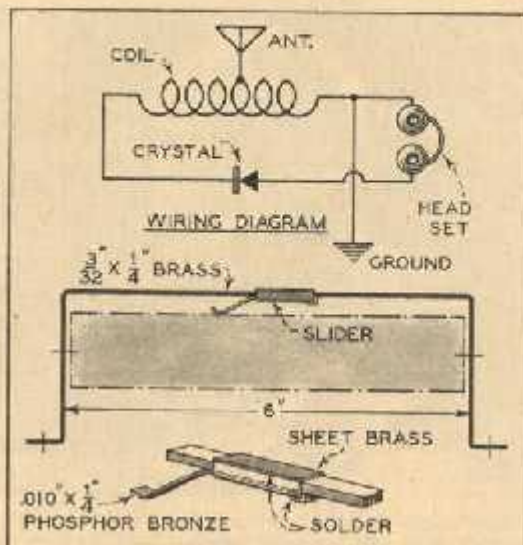
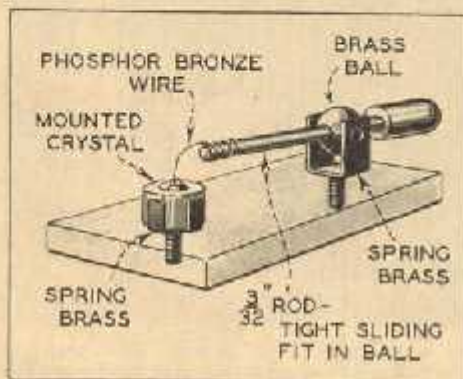



4/6  
45c  
A9

BECK BOOK CO. LTD.  
New and Secondhand Booksellers  
53 PULTENEY STREET,  
ADELAIDE, S.A.

# THE BOYS' BOOK OF CRYSTAL SETS

with practical circuits

by  
W.J.MAY

Medium, Long, and Short Wave designs  
12 different circuits to suit all areas and  
conditions · Complete practical wiring diagrams  
Comprehensive information on Aerial and  
Earth Installation · There are suitable designs  
for the beginner and advanced constructor  
BERNARDS RADIO MANUALS



# **THE BOY'S BOOK of CRYSTAL SETS**

BY

**W. J. MAY**



**BERNARDS (PUBLISHERS) LTD.**

**THE GRAMPIANS  
WESTERN GATE  
LONDON W.6**



*General Editor*  
**WALTER J. MAY**

First Published—March, 1954  
Second Impression—June, 1954  
Third Impression—April, 1955  
Fourth Impression—January, 1956  
Fifth Impression—February, 1957  
Sixth Impression—August, 1957  
Seventh Impression—March, 1958  
Eighth Impression—October, 1958  
Ninth Impression—April, 1959  
Tenth Impression—December, 1959  
Eleventh Impression—April, 1960  
Twelfth Impression—October, 1960  
Thirteenth Impression—March, 1961  
Fourteenth Impression—August, 1961  
Fifteenth Impression—January, 1962  
Sixteenth Impression—November, 1962  
Seventeenth Impression—August, 1963  
Eighteenth Impression—September, 1964



*Printed by V. Cooper & Partners, Ltd., Flitcroft St., W.C.2*  
*for Bernards (Publishers) Ltd., The Granpians, Western Gate, London, W.6*



# CONTENTS

	<b>Page</b>
<b>Preface</b> - - - - -	<b>4</b>
<b>Introduction</b> - - - - -	<b>5</b>
<b>Receiver No. 1</b> - - - - -	<b>12</b>
<b>Receiver No. 2</b> - - - - -	<b>13</b>
<b>Receiver No. 3</b> - - - - -	<b>14</b>
<b>Receiver No. 4</b> - - - - -	<b>16</b>
<b>Receiver No. 5</b> - - - - -	<b>19</b>
<b>Receiver No. 6</b> - - - - -	<b>20</b>
<b>Receiver No. 7</b> - - - - -	<b>23</b>
<b>Receiver No. 8</b> - - - - -	<b>24</b>
<b>Receiver No. 9</b> - - - - -	<b>26</b>
<b>Receiver No. 10</b> - - - - -	<b>27</b>
<b>Receiver No. 11</b> - - - - -	<b>30</b>
<b>Receiver No. 12</b> - - - - -	<b>31</b>



## P R E F A C E

**The Publishers make no apology for reviving interest in the crystal set. For too long the technical press has immersed itself in an orgy of complex superheterodyne receivers and television equipment, all of which is necessarily expensive. In the 1920's, crystal set construction was a fascinating and inexpensive pastime indulged in by the majority of boys of that day. Today this pleasurable hobby can be even more attractive, the introduction of the germanium crystal diode and high performance coils, has opened up new paths which will capture the interest of boys of all ages. Perhaps most important of all, not only can a receiver capable of impeccable reproduction be produced without any technical knowledge; but the cost is no greater than that of a few visits to the cinema**





# INTRODUCTION

Before any attempt is made to construct a receiver, it is necessary to examine the problems which surround the crystal set, so that the best can be obtained from any of the designs attempted.

Firstly, it must be understood that the crystal set as it is to-day does not provide any amplification. It relies entirely on what is fed into it via the aerial and earth system and gives a very faithful replica of the original transmission.

From this it will be obvious that the aerial and earth system must be as efficient as possible if the final results are to be in any way outstanding. This because these are the only means by which the signals are fed to the receiver.

Secondly it is necessary to understand the nature of the transmitted signal, then it will be easy to understand the working of the set and to appreciate the function of each of the components.

When crystal sets first became popular, very little information was generally available, at least, not in a form that school-boys could understand.

We all built sets of all shapes and sizes, with coil designs that had to be seen to be believed, but very few of us had much idea of how they worked.

I well remember the case of a cousin of mine who, in those days acquired a magnificent variable capacitor or condenser as it was then called, this instrument had a most impressively engraved dial of polished ebonite, brass vanes and nickel plated end plates. Having observed similar dials on several highly priced commercial receivers in the town, he at once ripped out the somewhat tattered coil from the family receiver and replaced it with this device. The profound silence which ensued caused considerable amazement and dismay until a better informed adult explained the mysteries of L and C to him. Readers of this manual, however, will be better informed and there is no risk of failure with any of the designs described provided the instructions are carefully followed.

## The Signal

To commence, we will assume that an orchestra

is playing in a broadcasting studio. Since the principle of radio transmission is electrical it is necessary to change the sound produced by the orchestra into an electrical equivalent. This is carried out by the microphone, which picks up the sound and changes it into minute electric currents.

As they appear at the output of the microphone they are too small to be of use and accordingly are passed through a high power amplifier. These amplified currents could now be transmitted, but unfortunately, as we shall learn, owing to the inherent nature of the signal in this state, transmission over any useful distance would be impractical.

When the music from the orchestra is transformed into electrical currents they are in the form of alternating currents, usually called A.C., that is they rise to a maximum in one direction, fall to a minimum, rise to a maximum in the opposite direction and then fall to minimum again. This process is repeated over and over again. One complete rise and fall in each direction is called a cycle and is drawn in Fig. 1. Every time a note is struck on a piano, vibrations are sent out which reach the ear enabling you to hear it. These vibrations are also spoken of as cycles, they rise and fall in intensity the same way as an alternating current. The number of cycles radiated by any given note over a period of one second are referred to as its frequency. Middle C on the piano sends out 261 cycles every second and is known as having a frequency of 261. The microphone also "hears" the note and in the case of middle C produces minute A.C. at 261 cycles. This can be drawn as in Fig. 2, the only difference between Fig. 1 and 2 is, that the time factor is given so that the frequency can be identified. The higher the pitch of a note the higher the frequency and the lower the pitch the lower the frequency. On a piano the frequency of the top note is 3515 cycles and that of the lower 27 cycles. Those of you who have listened to an organ in a concert hall will have noticed that when a very deep note was played, it sounded like a growl to the ear, but the vibrating fre-



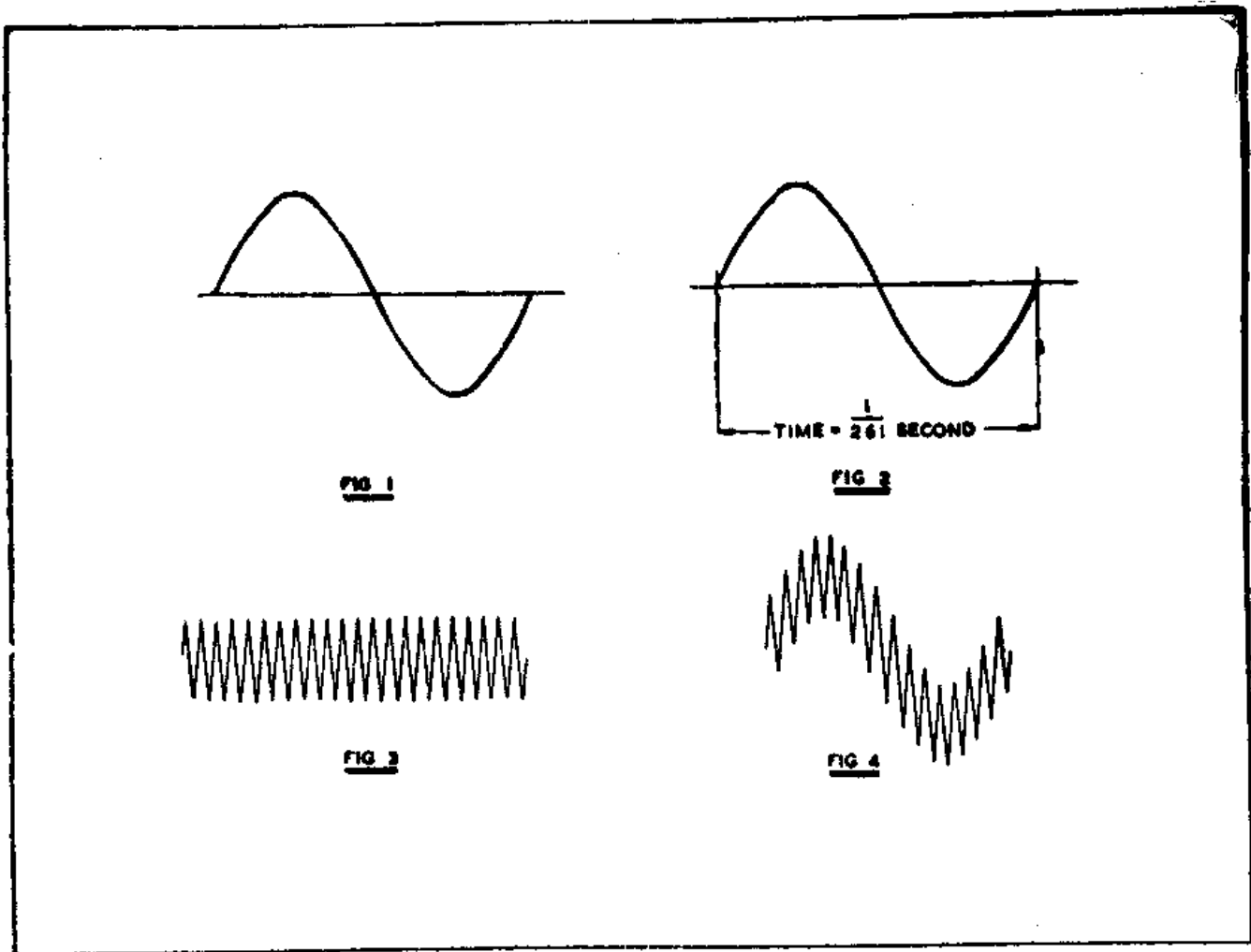

quency could be distinctly felt through the seat. Higher notes have too high a frequency to be observed in this manner.

The range of sounds which can be detected by the human ear are known as audio or low frequencies. From this you will understand that a low frequency amplifier is one which amplifies sound.

So that the transmitter will carry the programme over a useful distance it is necessary to radiate high frequencies. Now, as explained, the programme to be transmitted consists of low frequencies, and to overcome the difficulty, the transmitter generates A.C. of high frequency and combines it with the low frequencies. It will now be understood that the transmitted signal consists essentially of two different parts, a high and a low frequency content.

Fig. 3 gives a representation of the high frequency signal generated by the transmitter. In the case of the London Home Service, the frequency is 908000 cycles.

When referring to a high frequency signal on the medium or long wave-band it is usual to express the frequency in thousands of cycles, thus

908000 cycles becomes 908 kilo-cycles, which in turn may be abbreviated to 908 k/cx. It might at first be thought that by adding the low frequency or L.F. signal to the high frequency or H.F. carrier a form such as in Fig. 4 would result, such a combination is useless, and, so that the original L.F. content can be satisfactorily extracted by the receiver, the L.F. signal must vary the amplitude or output power of the H.F. signal as in Fig. 5.

It is in this form that the signal arrives at the receiving aerial. The aerial in itself is incapable of discriminating between one signal and another, and countless signals will be collected by the aerial at any one time. Many of these are too weak to be of use but the stronger ones must be sorted out since there is no point in receiving several programmes at once.

Fig. 6 shows the basic circuit of the input to a crystal. The coil L possesses a quality known as inductance, and the capacitor C, that of capacitance. If the coil had no capacitance whatever across it, all signals arriving at the aerial would be effectively short circuited to earth. As a matter of interest, it is impossible to obtain this state of affairs since even without any additional capa-



citor any coil **must** contain a certain amount of self capacitance.

By combining a coil and capacitor as in Fig. 6 a peculiar effect is observed, at one particular frequency, the signals are not short circuited to earth, but are developed across the coil. In other words the combined effect of L and C no longer provides a short circuit, **but only at one particular frequency**. If the value of C is altered the effect will be observed at a different frequency; likewise by altering L the frequency at which the effect will take place can be changed. There is a name for this phenomena, the frequency at which it occurs with any given L and C combination is known as the **resonant frequency**.

The values of the coils and capacitors shown in this manual have been carefully chosen so that resonance will be obtained at all frequencies where stations are broadcasting. Broadcasting stations work in bands of frequencies, those of major interest to crystal set constructors are the medium wave-band 1200 k/cs—600 k/cs and the long wave-band 300 kc/s—150 k/cs.

Usually a variable capacitor is used with a fixed inductance to cover one band and an additional

coil switched in to increase the inductance to cover the other. In this way the L and C combination can be adjusted to provide resonance at the desired frequency of any given station. In other words you can **select** the station you want by varying C, that is turning the dial of the variable capacitor. This procedure is referred to as tuning. Having selected or tuned the required station it still remains necessary to change the form of the signal back to that of the original transmission. This process is called detection or de-modulation.

Examination of Fig. 5 will show that the signal has been duplicated, in other words, as it rises in one direction it also rises equally in the other. In this form the signal is useless since each half of the signal cancels the other, and if this signal is applied to a pair of headphones silence will result. Obviously some provision must be made to get rid of the unwanted half of the signal, and it is here that the crystal detector must be considered. This device will pass current in one direction only, ignoring any signal in the opposite direction, so that if the signal of Fig. 5 is passed through such a crystal, that of Fig. 7 will result. There is still the H.F. content to be reckoned

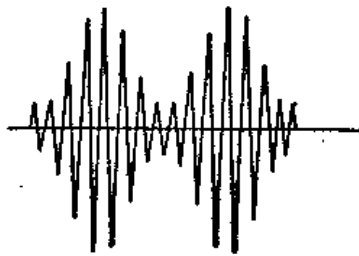

FIG 5

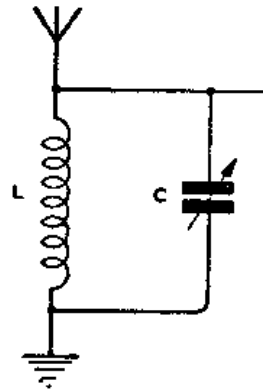

FIG 6

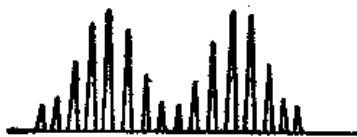

FIG 7



FIG 8



with, fortunately this is easily dealt with, a capacitor connected across the headphone terminals effectively disposes of this, leaving only the audio or L.F. content, as shown in Fig. 8. This audio content, which is a faithful replica of the original transmission is fed to the headphones. These in turn reverse the process of the microphone and transform the electrical currents into sound waves acceptable to the human ear.

Briefly then, your requirements are as follows:—

- (1) A good aerial and earth installation, to make the most of the available signals.
- (2) A receiver containing:—
  - (a) Some form of coil and capacitor (L & C) combination to select or tune in the wanted station.
  - (b) A crystal to get rid of the unwanted half of the signal (detection).
  - (c) A fixed capacitor across the headphones to get rid of any remaining carrier.
- (3) A pair of sensitive high resistance headphones.

### Aerials

By this time the intending constructor will be able to appreciate the necessity of a good aerial. It is a point which cannot be over-emphasised. Assuming that you are in the fortunate position of being able to erect an outdoor aerial there are two main considerations, height and length.

One of the best that can be used is the inverted L shown diagrammatically in Fig. 9.

It should be erected as high as is practical, every foot counts. The horizontal wire, that is the aerial proper, should have a minimum length of 60' to which of course the length of the down lead is added. Where it is impossible to erect an aerial with an ideal horizontal length, a compromise must be effected.

Fig. 10 shows a three wire spreader aerial which gives quite a good effective length.

Suitable wire for a receiving aerial will not set any problems, stranded copper about 7/22 gauge is the best. 7/22 means that it consists of 7 strands of 22-gauge wire. This wire may be obtained covered, and for the present purpose is better than the plain or enamelled kind.

Note that insulators are used between the actual aerial wire and its anchoring supports, it is important that these are used, otherwise leakage will occur which will of course spoil its efficiency. Fig. 11 and 12 show how the wire may best be attached to two of the most common types of insulator available. Fig. 11 is of porcelain and is usually referred to as an egg insulator, whereas Fig. 12 shows a more modern (and more expensive) type in glass. If you are using

the glass pattern, one is usually sufficient at each end of the aerial, but with the egg type two should be used. No doubt many readers will not be in a position to erect an out-door aerial, and must necessarily be content with an indoor installation.

The next best thing to a good out-door aerial is a replica constructed in a loft. If this form of construction is used, care must be taken when feeding the down lead to avoid close contact with the wall of the house. At the point where the lead feeds under the eaves, a length of rubber tubing can be used to cover the wire. The lead is fed through one of the small spaces left for ventilation purposes. A general idea is given by Fig. 13.

A less elaborate but quite effective aerial can be obtained by using a bed-spring. A length of 7/22 copper insulated wire is connected between the receiver and the spring. The spring should first be cleaned with emery cloth. Remove about 2" of insulation from the wire and bind it tightly round the prepared spring. The joint may be covered with insulating tape which is obtainable from all electrical stores for a few pence.

Such aerials are quite popular since so many crystal sets are built for bedroom use.

When an aerial is required in the living room, the picture rail can be conveniently used. Insulated screw-eyes are fixed at intervals of about 3 feet along the rail, the wire is firmly anchored to one of them, and stretched right round the room until you arrive back at the starting point. By use of one of the insulated screw-eyes, the wire is secured and the down lead fed to the receiver. The idea is illustrated in Fig. 14.

### Soldering

Before leaving the subject of aerials, a few words on soldering will not come amiss. Down leads on outdoor aerials should be soldered, and the same applies to loft types. Apart from aerial leads; earth leads and all the connections in the receiver will require soldering.

For the type of soldering necessary in radio construction an electric iron is the best solution. One of the small types marketed by Adcola or Henleys will be found admirable for the job. These are excellent for actual set construction but are hardly large enough for soldering the down lead to an outdoor type of aerial. Here the heat is dissipated much more quickly and a larger iron is required in order to get the solder to flow.

Ordinary irons which may be heated by a gas flame can be obtained very cheaply from most ironmongers' stores. Assuming the use of such an iron, first heat the iron until the copper bit is giving off a green coloured flame, the iron is now at the correct operating temperature. The bit is now discoloured or oxidised and its tip



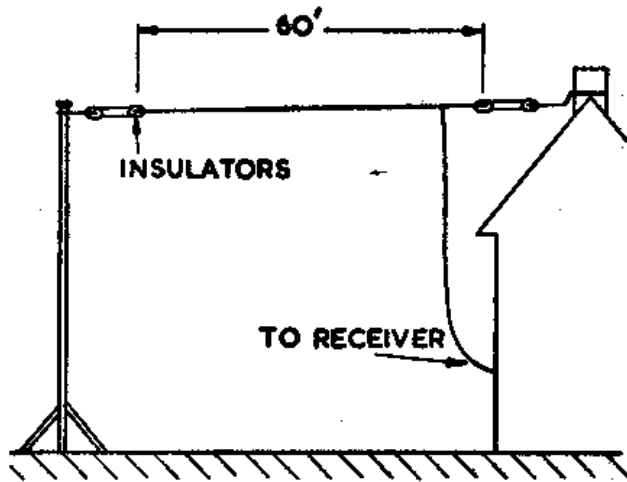

INVERTED 'L' AERIAL

FIG. 9

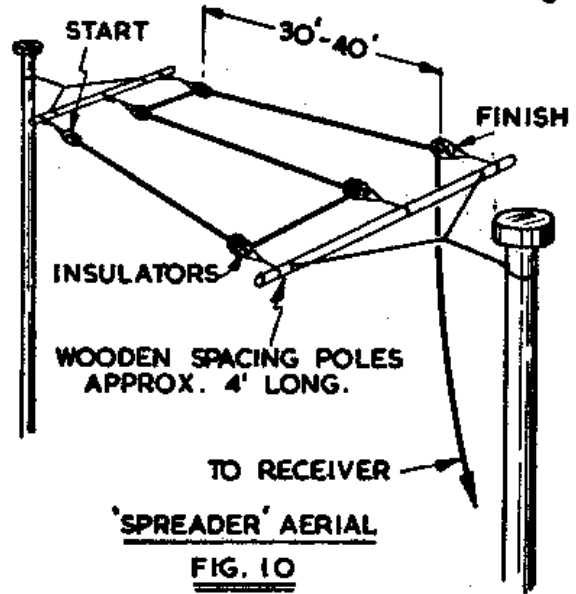

'SPREADER' AERIAL

FIG. 10

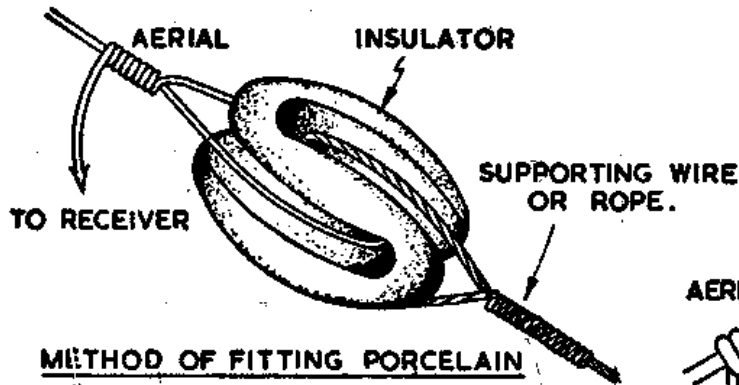

METHOD OF FITTING PORCELAIN  
INSULATOR

FIG. 11

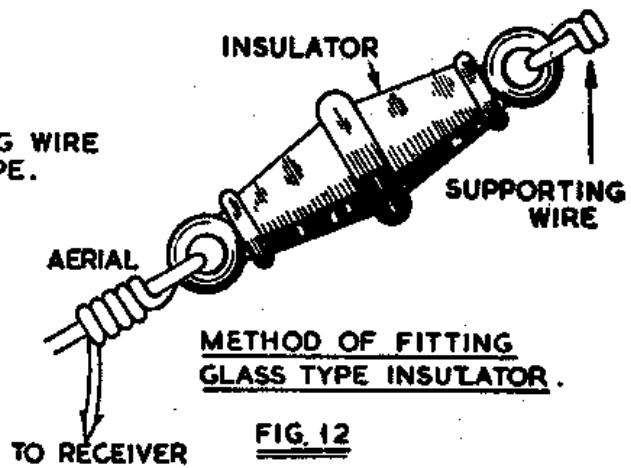

METHOD OF FITTING  
GLASS TYPE INSULATOR.

FIG. 12

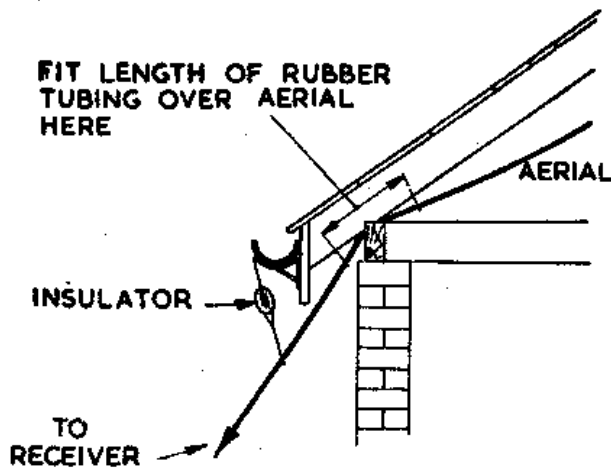

LOFT AERIAL.

FIG. 13

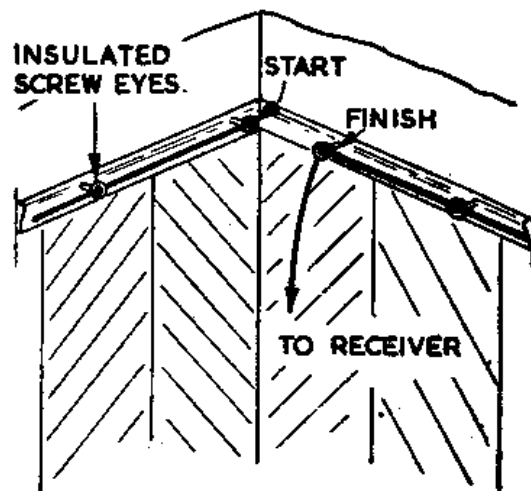

'PICTURE RAIL' AERIAL.

FIG. 14



should be quickly cleaned with an old file which should be kept specially for the purpose. A better idea is to obtain a small block of sal-ammoniac and rub the tip of the hot iron on it. This will clean the tip of the bit perfectly. Next take a length of cored solder such as Ersin Multicore, and melt a little on to the prepared tip faces, now smooth it evenly over the surface with a piece of old rag (be very careful not to burn your fingers) the iron is now "tinned" and ready for use. When heating the iron, be very careful not to let the bit overheat or get red hot, otherwise the tinned surface will be destroyed and the whole process will have to be gone through again.

An electric iron will not overheat, and the tinning will last much longer than with ordinary types, and since the heat does not deteriorate there is less likelihood of making faulty joints.

Having obtained a tinned iron, the process of soldering joints is remarkably simple and anyone with a little patience can acquire the art in a very short time.

To solder two copper wires together: clean the wire with emery cloth, apply a prepared iron and some cored solder to it, the solder will flow evenly over the wire thus tinning it. Repeat the

process with the remaining wire and then twist the two together. Now apply the iron to the joint from the underside and the cored solder to the joint on top. Solder will flow evenly over the joint. Remove both iron and solder and allow to set. The solder will harden or set in a few seconds but during this period the joint must not be touched or moved, as otherwise the joint will be "dry" and quite useless mechanically or electrically. On radio components, tags for soldering are already tinned though if they are old, or discoloured it is best to re-tin them. Normally, however, it is only necessary to twist the connecting wire to it and apply the iron and solder as explained.

Remember: never apply the solder to the iron and then the iron to the joint, always apply the iron and the solder to the joint. It is however a good thing to apply a little solder to the iron tip even when it is perfectly tinned just before making a new joint.

One final "DON'T," you will have noticed that the solder referred to is "cored," that is, it contains resin and other substances through its centre, plain solder as used by electricians and plumbers will not do, as it is the resin or flux

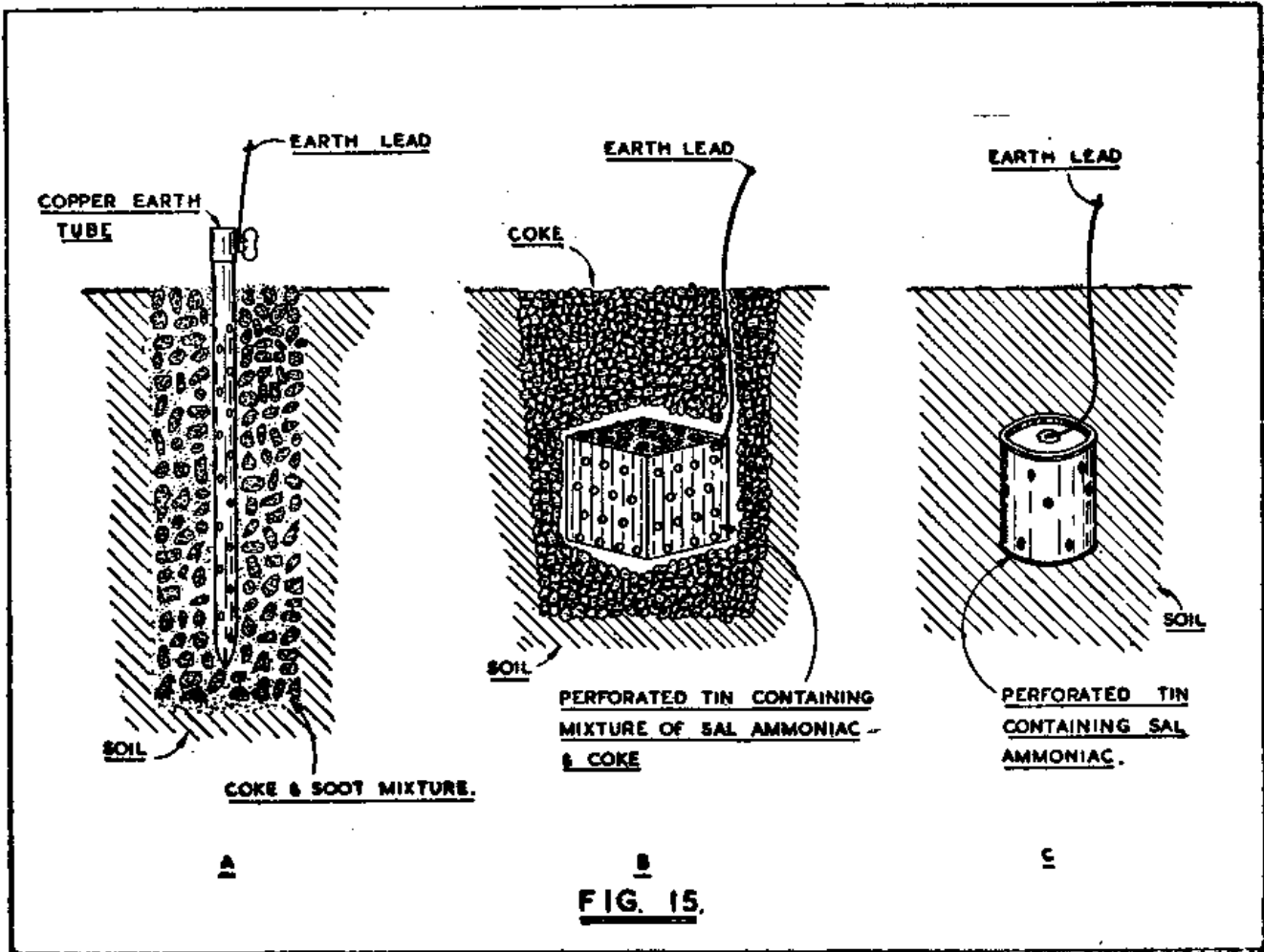



as it is called which makes the solder flow evenly and permits a good electrical joint.

Equally important do not attempt to use a separate flux or soldering fluid with plain solder or to "help" the cored solder, since these are almost certain to cause eventual corrosion and will destroy any components that have been contaminated.

### Earths

The provision of a good earth is just as important as the rest of the installation.

Much disappointment would be avoided if this fact were not lost sight of, to avoid any slip up in this direction I am proposing to outline several well tried and efficient earth systems.

If it can be obtained, an earth rod, specially designed for the purpose provides the basis of a good earth connection. These were very popular some years ago when the majority of receivers were either crystal or battery operated, but in these days of modern mains driven sets they are not often used and consequently not always readily available.

Fig. 15 shows how it is used. First excavate a hole to a depth of three feet and fill with a mixture of soot and coke. Drive in the earth rod, which is a hollow copper tube, perforated. The lead to the receiver is connected at the top, and should be of covered 7/22 gauge, as used for the aerial system. Though not obvious it is important that this lead-in should be in covered wire, otherwise a number of indifferent earth contacts are likely to be made at various points along its length until it reaches the set. This is very undesirable and will spoil the efficiency of the system. It is essential to keep the soil surrounding the rod moist, which is one reason why the tube is hollow, and care must be taken to pour water into the tube at intervals.

A very efficient earth is the percolative type also popular at one time. Due to the chemicals used, it will extract moisture from its surroundings, thus maintaining a permanently moist earth.

It should be installed as in Fig. 15b.

The container is of copper or zinc, anything else will quickly rust away, again a good quantity of coke is used. Fill the container with a mixture of sal-ammoniac and coke, and then bury in coke as illustrated. This earth will not require further attention. It is possible to use powdered calcium chloride instead of sal-ammoniac but unless a chemist can be persuaded to make some up it is better to stick to sal-ammoniac.

If a zinc container is not available and you do not use or cannot easily get coke, Fig. 15c should be used. This makes a better earth than many so-called "earths" that I have come across. Obtain as large a tin as possible, make a number of holes as shown. Solder the lead in the bottom

and fill it with sal-ammoniac. Replace the lid and bury in the ground. The tin will eventually rust away, but the replacement cost is negligible.

If it is quite impossible to make direct contact with the ground, a water pipe must be pressed into service. This should be a main pipe feeding straight to ground and not a hot water pipe or one fed from a tank. Scrape the pipe clean and twist the lead in tightly around it, a copper clip is even better. Do not attempt to solder on to the water pipe; since cold water is flowing through the pipe, it is extremely unlikely that your soldering iron will heat up the water supply sufficiently to allow a sound electrical joint, though you may spring a leak.

No attempt should be made to utilise gas pipes; the possibility of causing a fire is certainly very remote but, they make incredibly bad earth connections due to a number of joints made before true ground is reached. These joints are at best only semi-conductors, at least from an electrical standpoint.

### Headphones

Since the late war there have been a large number of head-phone sets available on the surplus market. These may be roughly divided into two types, high-impedance and low-impedance. For the crystal sets detailed in this book high-impedance 'phones are required and the low-impedance pattern will not be suitable unless a matching transformer is used. As this is likely to cost more than the rest of the installation including the set, it will be as well to avoid them.

High-impedance types have an impedance of 2000  $\Omega$  to 4000  $\Omega$  whereas the low-impedance types are usually 600  $\Omega$ .

The remaining consideration is weight; often cheap headphones are very heavy and uncomfortable to wear, every endeavour should be made to obtain 'phones as light in weight as possible.

### Crystals

All the sets shown in this book have been designed to work with modern germanium crystals rather than the older galena crystal.

These germanium crystals require no adjustment, which, in itself, removes the main objection to this class of receiver. Suitable crystals are available from the following manufacturers and on the surplus market: Mullard, G.E.C., Brimar, Westinghouse and B.T.H. They are of robust construction, some in glass, others in ceramic or plastic, but must not be subjected to heavy knocks, otherwise the contact point may become dislodged.

From the information given, you should now be able to install an excellent aerial and earth system, and have some idea of how the crystal set works, so it is time to pass on to the actual receiver construction.



# CONSTRUCTION 1

If you examine the following circuits you will find that each one is different. In most cases the difference lies in the coil design and/or the method by which the crystal and aerial is tapped into it. Each of these circuits has its own particular advantage to suit different conditions and the ideal circuit in some localities is not necessarily the best in others. It is not just a matter of a given circuit giving louder results than another, if it were there would be no point in showing more than one.

The main problem is to obtain adequate selectivity without reducing the volume level.

A receiver is said to be selective when it tunes sharply, a set with poor selectivity allows the stations to spread over the dial and when used near a transmitter will receive the local stations mixed together, which of course is useless.

Consider Fig. 16a, this is a very simple receiver, with no special attempt to provide any great amount of selectivity. In areas where signal

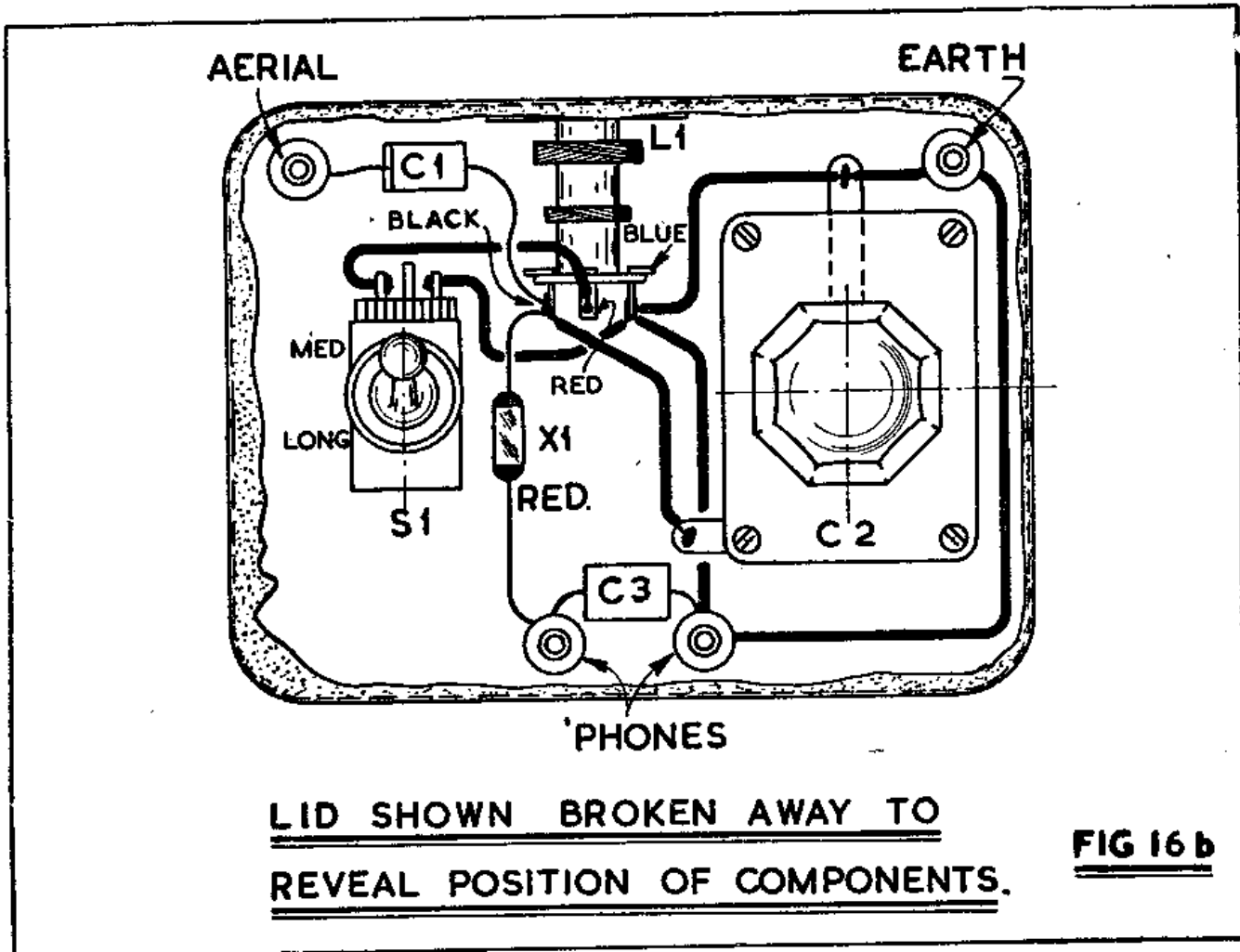
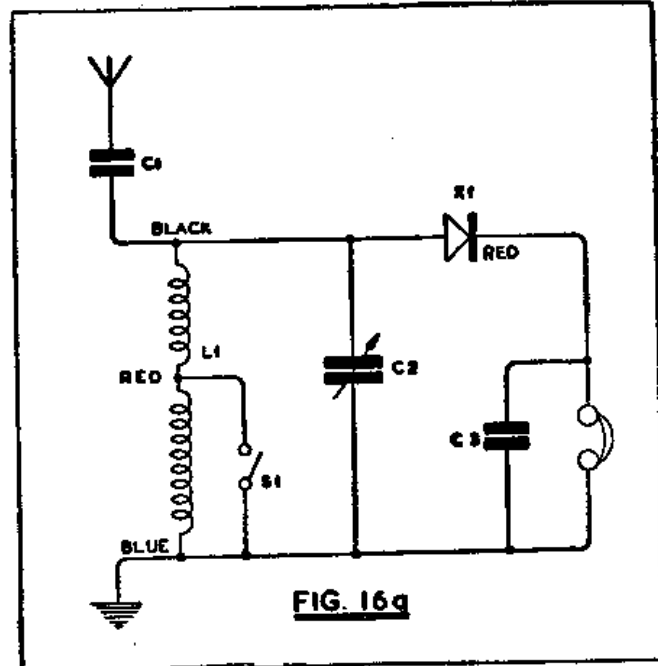



strength is not high, or a short aerial is used, it will probably be ideal.

It would have been quite easy to increase the selectivity by providing a tap on the coil for the aerial as in Fig. 17a, but unfortunately, as the selectivity is increased overall volume is likely to decrease, so that unless you live close enough to the transmitter to have a large signal available and therefore need the selectivity, the circuit of Fig. 16a will be quite satisfactory.

Capacitor C1 is to prevent the aerial damping the circuit too heavily because this would flatten the tuning unnecessarily, however with small aeriels it may be better to take the aerial direct to the black tag on L1. The signals are selected or tuned by L1 and C2, X1 is the crystal and C3 the capacitor across the 'phones to prevent unwanted carrier or R.F. reaching the 'phones.

A practical diagram (Fig. 16b) is provided showing the layout and all the wiring. You will require nuts and bolts to fix the coil, about 1/2", 4BA size will do, the other parts have locking nuts provided. An old 2-oz. tobacco tin makes a very good container and keeps the size down. Note that the metal box is connected to earth. With the exception of AC/DC receivers the metal

work on any receiver or amplifier is connected to earth.

When S1 is open as in the diagram, the set will tune in long-wave stations, but when closed the medium wave-band will be received.

Components List, Fig. 16a

- C1 100pF mica capacitor.
- C2 500pF tuning capacitor, solid dielectric.
- C3 1000pF mica capacitor.
- X1 Germanium crystal.
- L1 Crystal Set Coil. R.E.P.
- S1 Single Pole toggle switch.
- 4 Insulated wander-plug sockets and plugs.
- 1 2-oz. tobacco tin (or similar container).

Make sure that the wander-plug sockets are of the insulated type, otherwise the metal case will join all the sockets together electrically.

Try to follow the theoretical diagram when wiring, a little practice will soon enable you to wire up a set without a practical diagram, which is a great advantage because often only the theoretical diagram is given when circuits are detailed in the technical press.

Fig 28 on page 34 gives a list of symbols used on the theoretical diagrams, so that you can readily identify the components.

2

Fig. 17a circuit is similar in many respects to that of Fig. 16a. The difference is purely one of selectivity, tuning will certainly be sharper, and even with comparatively inefficient aeriels the design will put up a very good performance. There is no reason why the construction should not follow the same lines as the previous receiver but, by enlarging the set a little and using an air spaced tuning capacitor, the efficiency is improved. Observe that the colour coding on the coil, an R.E.P. Dual Range (Blue Box) is different from that of the Crystal set coil used on the previous design, and make sure it is correctly wired in.

C1 is a mica compression capacitor, often referred to as a "trimmer" and because it is adjustable, permits the set to be matched to aeriels of varying lengths. Construction is carried out on a square panel of bakelite, perspex or wood, as shown in Fig. 17b. Perspex being clear like glass presents a most attractive finish, provided the set is neatly wired. It must be drilled slowly, however, otherwise the generated heat of the drill will make the hole wander, and spoil the panel.

After the set has been wired and tested a small wooden container can be made to house the completed set.

When carrying out reception tests, a little experiment is well worth while, to get the best out of the set. Try removing the germanium crystal

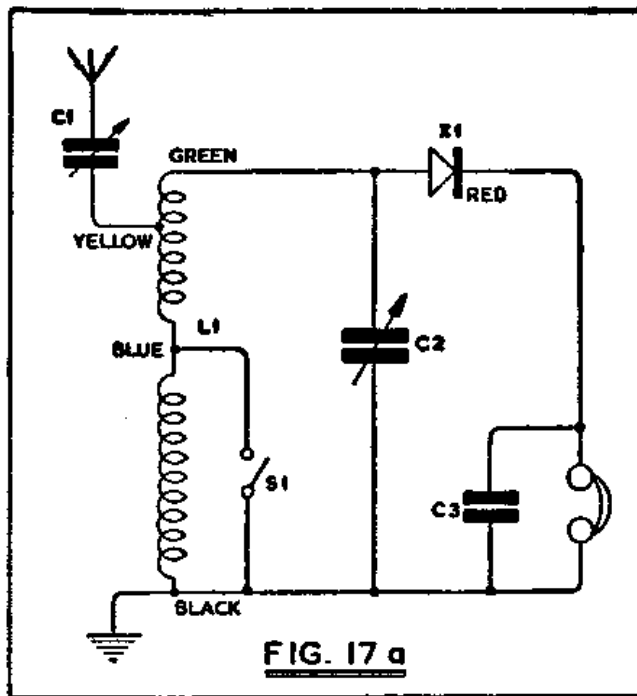

from the green tag on L1 and connecting it to yellow, at the same time removing the lead from C1 to yellow and connecting it to green. Once the best arrangement has been found the wiring



can be left permanently in that position. Note that two tags on the coil are unused, this is intentional because on this circuit the extra winding connected to these tags is not required. With the switch S1 closed, the coil will cover the medium wave-band, and when open, long wave stations can be received. It is customary to abbreviate the expression medium wave-band to M.W. and long wave-band to L.W.

**Components List, Fig. 17a**

- C1 100pF mica trimmer capacitor.
- C2 500pF variable capacitor (air spaced).
- C3 1000pF mica capacitor.
- L1 Dual Range Coil R.E.P. (Blue Box).
- S1 Single Pole toggle switch.
- X1 Germanium Crystal.
- 4 Terminals or wander-plugs and sockets. Perspex, bakelite or wood for mounting panel.

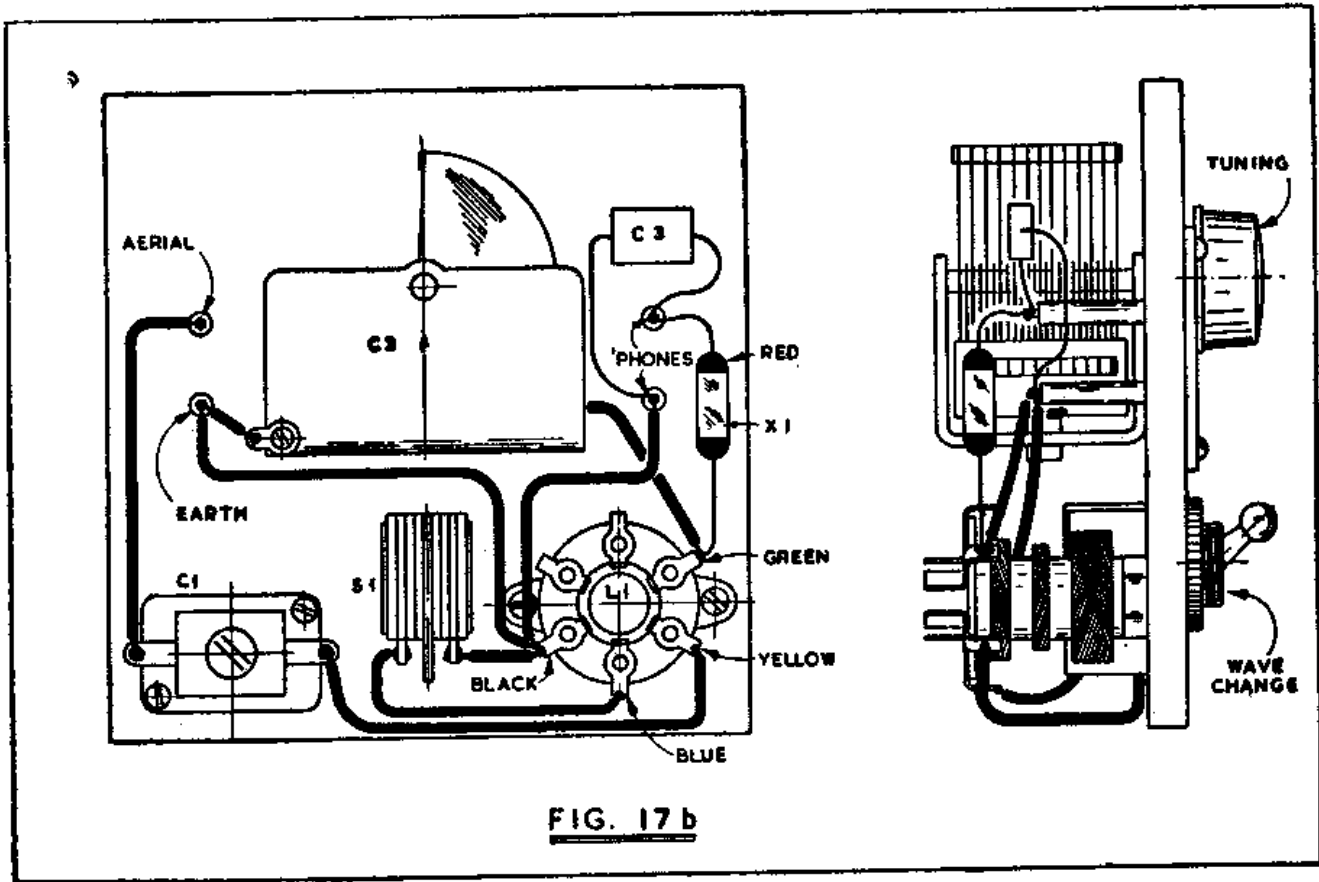

3

The design shown in Fig. 18a and 18b is more flexible than either of the preceding sets. That is, it can be varied to suit local conditions to a greater extent than the first two sets. This is made possible by the large number of taps provided on the coil.

You will notice that in this instance the coil is home-constructed on a cardboard former and is much larger than commercially produced coils. Coils wound in this manner are called solenoids, the turns are wound on side by side; in this case to a depth of some three inches. The diameter of the coil is made purposely large so as to obtain high efficiency. Modern commercial coils are invariably wave-wound and quite often are litzendraht which is the German for litz wire.

This wire is made up of a number of strands of fine copper wire, each strand is enamelled to insulate it from the others, the whole is then silk covered. Litzendraht is more efficient than solid copper wire, and by using this and wave-winding, manufacturers can produce an efficient coil which is also small. Unfortunately wave-wound coils cannot be produced without a complex winding machine and home-constructed coils must take the solenoid form. It would be possible to use litzendraht but it is not easy to obtain by the reel, it is most expensive, and is difficult to handle. This last point is because at termination points, each strand must be cleaned of its enamel before a joint is made, and if one strand is broken, its advantage over plain copper wire is lost. How-



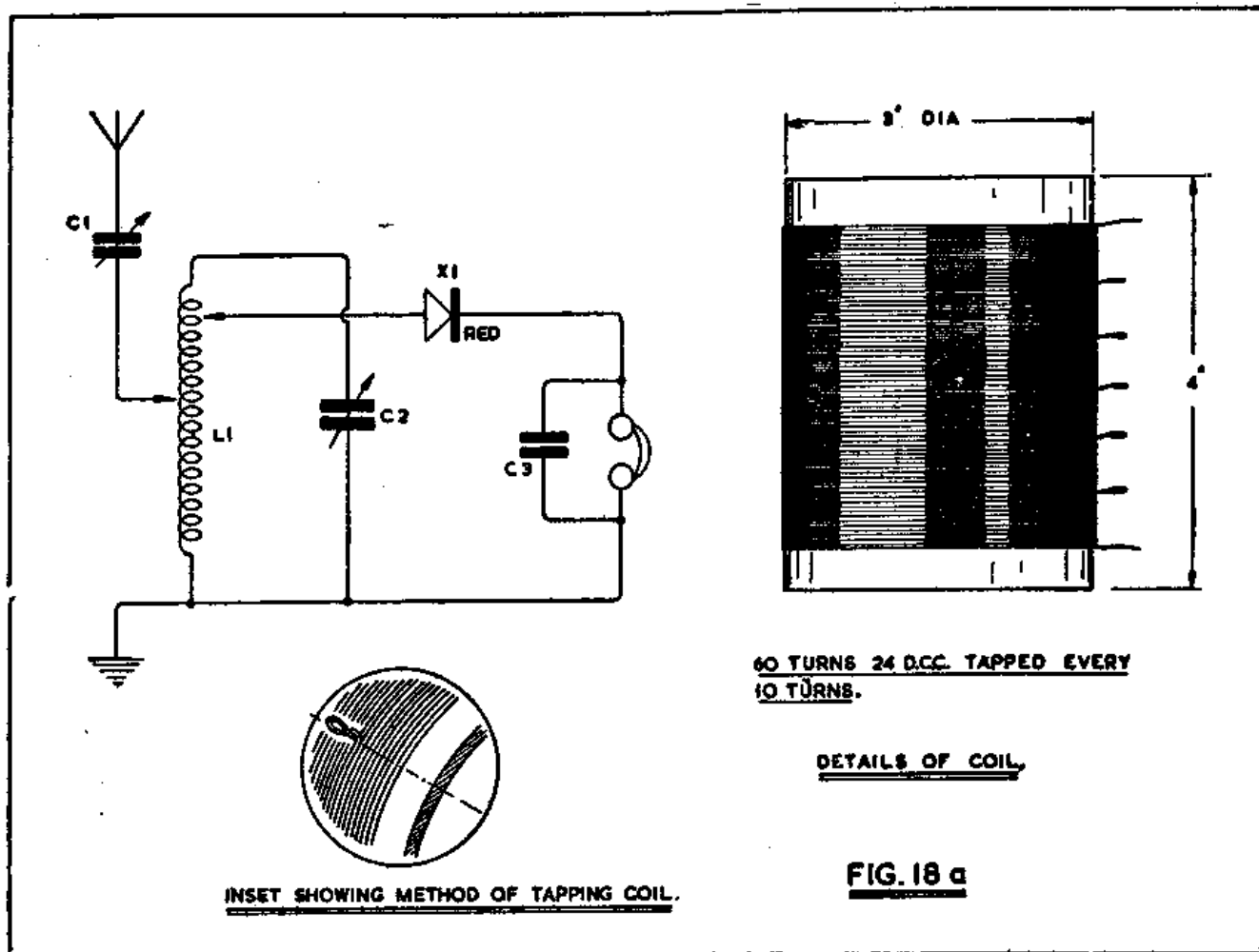

ever, by using a former of reasonably large dimensions an efficient coil can be produced cheaply using ordinary copper wire.

The wire must be firmly secured at the start and finish of the windings. Pierce three small holes about  $\frac{1}{4}$ " apart  $\frac{1}{2}$ " from the end of the former. Pass the wire through the first from the outside, return it through the second and pass it back again through the third. Leave some 6" of wire at the end to make off the connection. It will now be possible to wind the turns on tightly without wire slipping.

Count on ten turns and make a loop 1" long. The method of preparing loops is shown in Fig. 18a, loops or taps should always be made in this manner, never by baring the wire and soldering a further length of wire to it. Carry on with the winding, making off the taps every ten turns as directed until the coil is complete.

Construction is carried out on a wooden base-board and front panel. Secure the coil to the base-board as shown on Fig. 18b, mount the remaining components and proceed with the wiring.

When testing out, it will be found that the further the aerial is tapped down the coil towards the earth end, the greater the selectivity. A position should be found which permits separation of local stations without excessive loss of sensitivity.

The crystal tap is adjusted for best results and different settings of C1 tried out, when choosing the best position for the aerial tap.

**Components List, Fig. 18a**

- C1 450pF padder.
- C2 500pF variable capacitor.
- C3 1000pF mica capacitor.
- L1 See text and Fig. 18a.
- X1 Germanium Crystal.
- 2 Crocodile Clips (to connect leads to coil taps).
- 4 Wander-plugs and sockets.



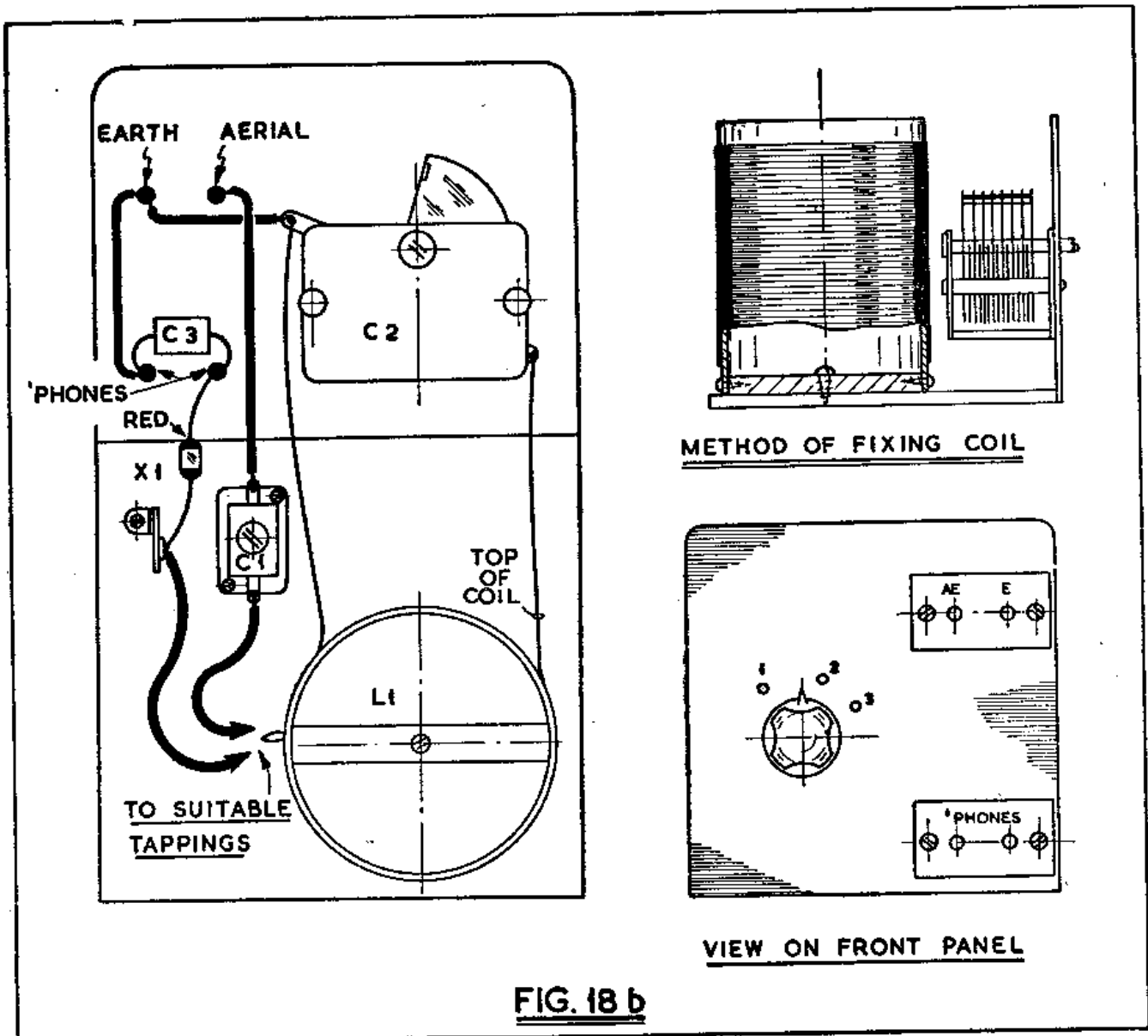

FIG. 18 b

4

A most unusual design is reproduced in Fig. 19a.

It first appeared in America about three years ago, and it certainly does offer some advantage over more conventional sets. The tuning circuits are duplicated and two crystals are used, so the circuit may be described as a full-wave receiver. Signals received will certainly be louder than with simple sets, but care must be taken with the coil winding, as with the other receivers using home-made coils, otherwise results will be disappointing. Be very careful to ensure that all three windings are in the same direction, this is very important.

The distance between each winding should be  $\frac{1}{4}$ ". After the coil has been wound it is a good

plan to warm it before a fire and paint the windings with "Durafix." Heating the coils makes the "Durafix" run freely. This substance sets quite hard and there will be no risk of the windings loosening. A small quantity of enamelled wire will cover the requirements of this coil, a 2 oz. reel will provide more than sufficient.

Before wiring in the germanium crystals, examine them carefully, note that one end is coloured red or in some cases marked with a positive sign thus +. You will notice, the sign is the same as the addition symbol used in arithmetic.

It is essential that both the red or positive ends are connected together, note that this is clearly marked on Fig. 19b. The receiver cannot work if



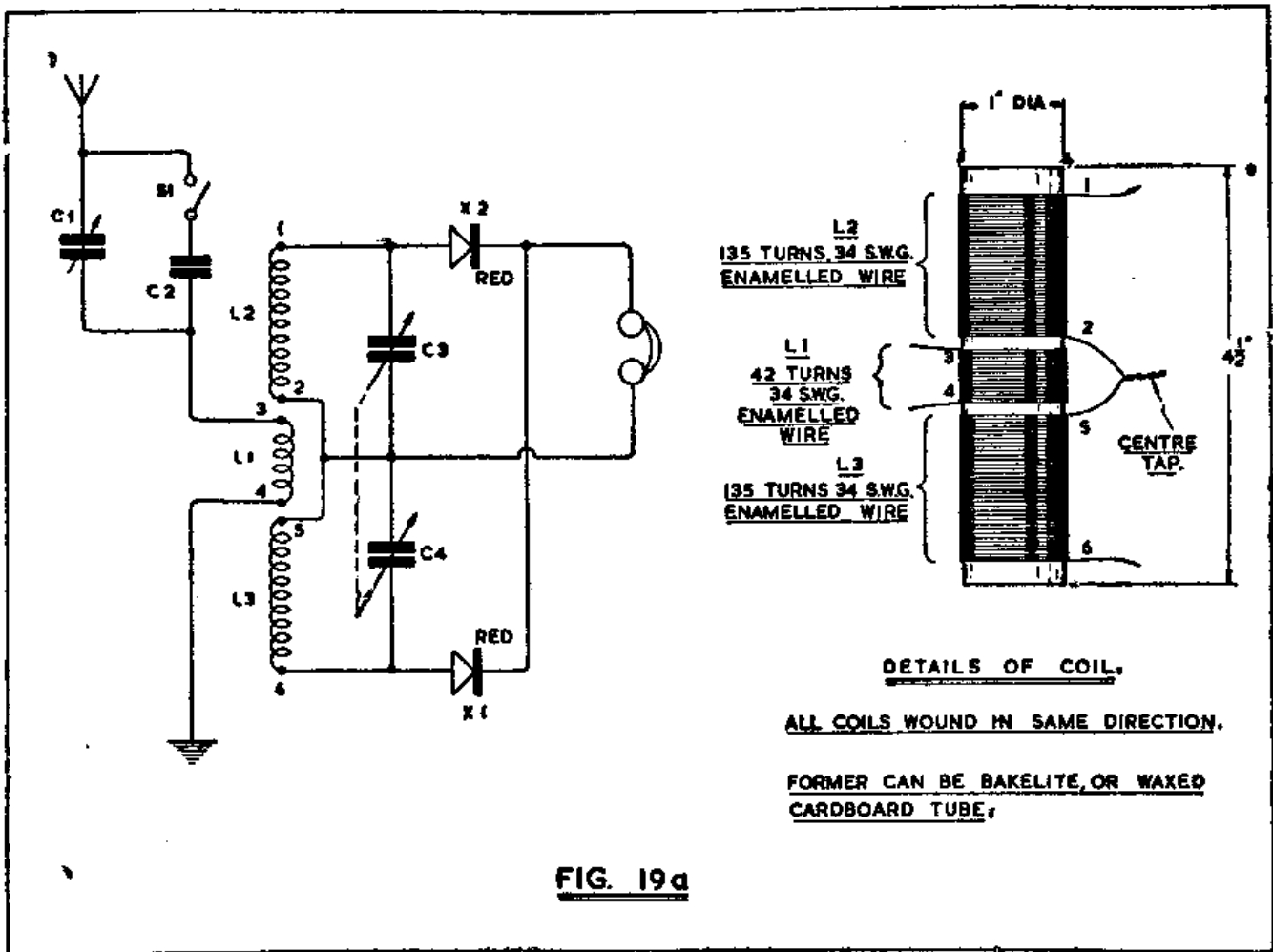

one of the crystals is connected the reverse way round.

A baseboard and panel form of assembly is used for this set which looks quite attractive if housed in a small polished cabinet. Dimensions are not at all critical but Fig. 19b gives a general idea of the layout that should be used. To avoid any unnecessary losses the coil should be mounted on perspex.

Obtain two strips of perspex  $5\frac{1}{2}$ " long by  $\frac{1}{2}$ " wide, drill fixing holes at both ends of each strip. It is best to clamp the two together when drilling these holes. Place one strip on the board in position, then put the coil and remaining strip over the first one and screw down. The coil will be clamped neatly and rigidly into position.

Twin socket bakelite strips are used to carry the aerial/earth and 'phone connections, if de-

sired terminals mounted on pieces of bakelite could be used. These socket strips can be purchased from most shops selling components. If feet are not provided, drill two holes and screw into the edge of the base-board. Tag-strips are used to anchor some of the wires from the coil, and the germanium crystals. These also can be purchased for a few pence. At least two tags are necessary on one, and three on the other, though if the strips have more tags than required it is of no consequence. C3-C4, the ganged tuning capacitors have trimmers fitted, this should be stipulated when purchasing, and when first operating the set these small trimming capacitances are set about half-way. The idea of these trimmers is, that they compensate for any difference between the self-capacity of the tuning coils. With the switch S.1 open, that is in the OFF position, tune



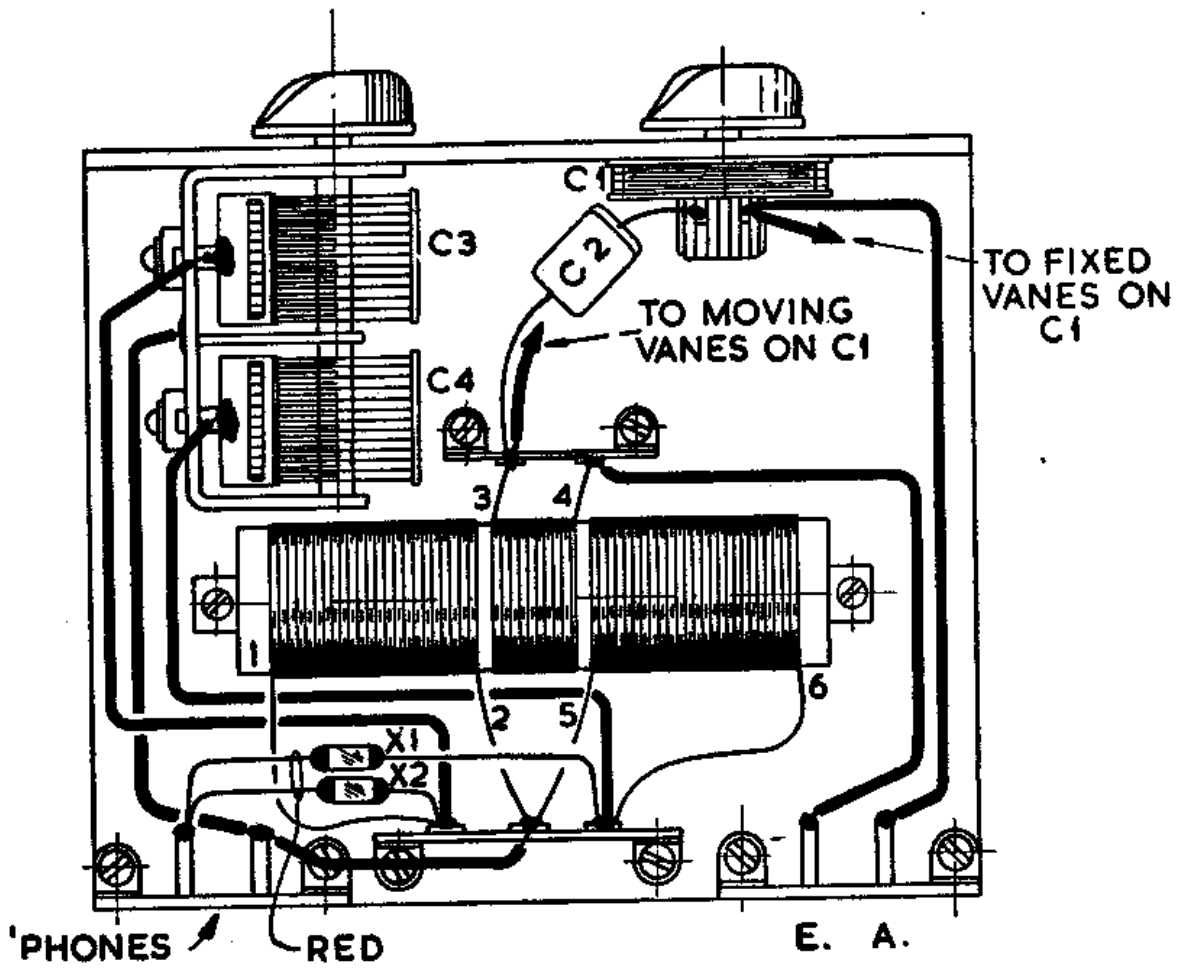
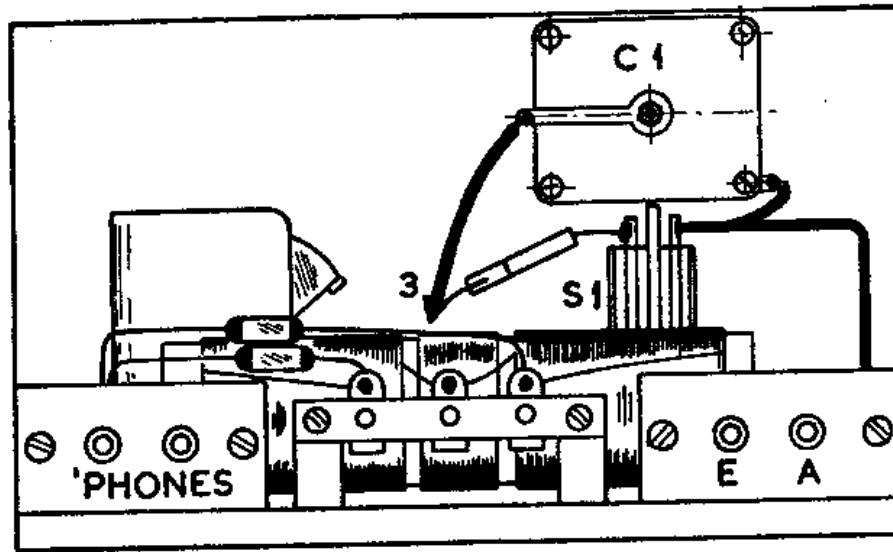

FIG. 19 b



in a station at the high-frequency end of the band, that is with the vanes of C3-C4 towards the disengaged position. Adjust C1 for maximum volume, without interference from other stations. Now adjust the trimmers for loudest headphone strength. It may be necessary to run over the adjustments several times for best results. Once they are correctly set, the trimmers require no further adjustment. The tuning coil covers the M.W. band, 1500 kc/s. to 600 kc/s., as the capacitor C3-C4 is advanced and the vanes start to mesh, the frequency to which the receiver tunes decreases so that with the vanes disengaged the set is tuned to 1500 kc/s. approximately and at full mesh, 600 kc/s. Switch S1 is used as follows, for stations lower in frequency than 850 kc/s it should be in the ON position with the contact closed, but for stations higher in frequency, it is in the OFF position. As an example both the London Home Service and London Light Programme transmitters on the M.W. band operate at a higher frequency than 850 kc/s. If any doubt exists as to the operating frequency of a given

station, reference should be made to the Radio Times which quotes both wave-lengths and frequency. If you know the wave-length in metres, it is simple to find the frequency. Divide 300,000 by the wave-length in metres, the dividend equals the frequency in kilocycles, i.e.,  $300,000 \div 300 \text{ metres} = 1,000 \text{ kc/s.}$  In the same way, dividing 300,000 by the frequency in kilocycles will produce the wave-length in metres.

To use the receiver, tune in the signal by C3-C4, adjust C1 for maximum volume without allowing stations to overlap.

**Components List, Fig. 19a**

- C1 300pF solid dielectric variable capacitor.
- C2 1000pF mica capacitor.
- C3-4 500pF twin gang variable capacitor.
- L1-2-3 See text and Fig. 19a.
- X1-2 Germanium Crystal.
- 2 Tag-strips.
- 2 Twin socket strips.
- S1 Single Pole toggle switch.

**5**

Whenever crystal sets are discussed, constructors are apt to think in terms of medium-wave reception. When you consider that at least 98% of published circuits are designed for this band (sometimes with the long-wave band thrown in as an afterthought) it is understandable. However, if you can provide a good outdoor aerial (and an equally good earth) there is a lot of fun to be had listening to the short-wave bands. This receiver is designed specially for short-wave reception.

A metal chassis is used for construction, these can be obtained ready made in aluminium from most good supply houses. It can be quite small and on the original model a 6" x 4" was used. Low loss components are used so as to obtain greatest efficiency on the short wave bands. The coil is a commercial product which plugs into a 4-pin base. Best results were obtained on the 3mc/s to 7mc/s band though coils covering other bands are available.

Note that the tuning capacitor C1 is smaller than normally used and has a maximum capacitance of 140pF.

Coil type 706/R covers the 3mc/s to 7mc/s band, but the set is equally satisfactory on the M.W. band, and to cover this coil type 706P should be used. This coil has an iron dustcore which can be adjusted to make the coil cover the required band. The effect of the core is as if turns were being added or removed from an or-

dinary coil. When dealing with the short waves it is customary to refer to the frequencies in terms of mega-cycles (mc/s) rather than kilo-cycles. One mega-cycle is equivalent to 1000 kilo-cycles, that is 1,000,000 cycles.

Layout and wiring can be clearly followed from Fig. 20b and a theoretical diagram is shown in Fig. 20a. Care should be taken when arranging a mounting for the aerial terminal. The best plan is to cut a 1" hole in the chassis, mount the aerial terminal on a piece of perspex and screw into the chassis. This avoids any unnecessary losses between aerial and chassis. The earth terminal is screwed directly into the chassis.

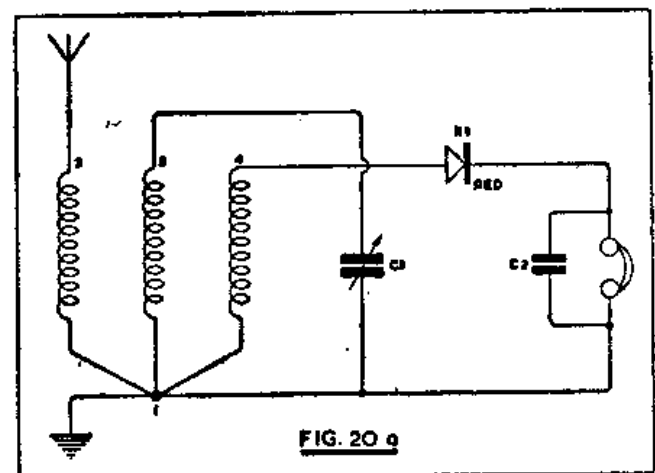
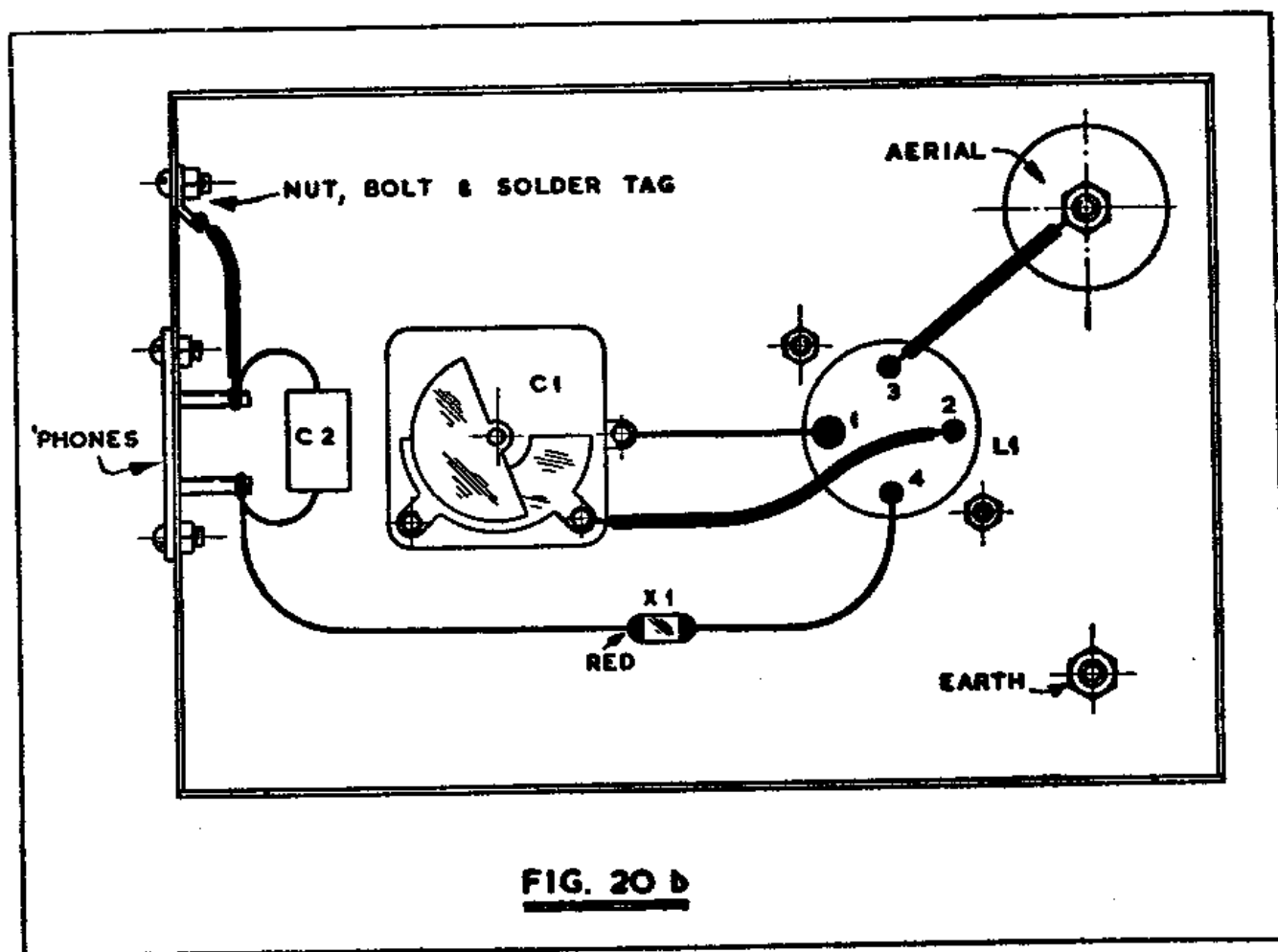

FIG. 20 a





Wiring as shown in Fig. 20a is likely to give the best results, but other arrangements are possible and to get the best out of the set they should be tried.

Refer to Fig. 20a. The aerial is connected to pin 3 on L1, C1 to pin 2 and X1 the crystal to pin 4. If you have a long aerial try this combination—Aerial to pin 4, C1 to pin 2, and the crystal to pin 3. Connections to pin 1 are not altered. In a few cases the following arrangement may prove best. Crystal and C1 to pin 2, aerial to pin 3, pin 4 left free and again pin 1 is unaltered.

Tuning on the short-wave bands is more critical than on the medium waves so tune very

slowly over the band and remember signal strength is likely to vary from day to day.

**Components List, Fig. 20a**

- C1 140pF variable capacitor Eddystone 586.
- C2 1000pF mica capacitor.
- 1 Coil holder Eddystone 707.
- L1 3m/c—7m/c coil Eddystone 706/R.
- 1 Engraved tuning dial.
- 1 6"x4"x2½" chassis.
- 2 Terminals (Aerial-Earth).
- 1 Twin socket strip (phones).
- X1 Germanium Crystal.

**6**

Fig. 21a-b is yet another design from America and appeared in Radio Craft some years ago, designed by Mr. W. J. Spain. The original used a silicon crystal which preceded the development of the germanium. Results are certainly very good though of course on the model built here,

a germanium crystal was used. Selectivity can be adjusted to suit all conditions and even at short distances from local stations. Good volume can be obtained without the programmes overlapping. Home made coils are used and for best results a 75' outdoor aerial is desirable.



Baseboard and panel construction is used, which can conveniently be housed in a small wooden cabinet.

Operation is a little more complicated than some of the other designs, but the results certainly merit the extra trouble taken. As with the other receivers much of the success obtainable is due to the coils and these must be carefully made otherwise results will be disappointing.

Layout and wiring can be followed quite easily from Fig. 21b and requires no special comment.

First make the coils. L1 is a tapped coil, the taps should be made in the same way as shown in Fig. 18b. It consists of 90 turns of 22 D.C.C. (double cotton covered) copper wire tapped at the following number of turns, 5, 10, 15, 25, 30, 40, 50, 60, 70 and 80. The former used has a diameter of 2". L2 is also wound on a 2" diameter former, this coil however is not tapped, it consists of 110 turns of 38 D.C.C. or enamelled copper wire. Great care must be taken when handling this wire, it is quite fine and in the

hands of the inexperienced will easily break.

After wiring has been carried out the set can be put into operation.

Selectivity is controlled by S2, in position B tuning is broad but in position A it can be quite sharp.

When searching for a station switch S2 to B. Tune the station and switch S2 to A. The frequency range is controlled by the position of the tap on L1, a good plan is to start with the 5 turn tap on L1.

**Components List, Fig. 21a**

- C1 500pF variable capacitor.
- C2 500pF variable capacitor.
- C3 1000pF Mica Capacitor.
- X1 Germanium Crystal.
- L1 & L2 See text.
- S1 Single Pole toggle switch.
- S2 Single Pole 2-way toggle switch.
- 2 Twin socket strips  
(Aerial/Earth and 'Phones).

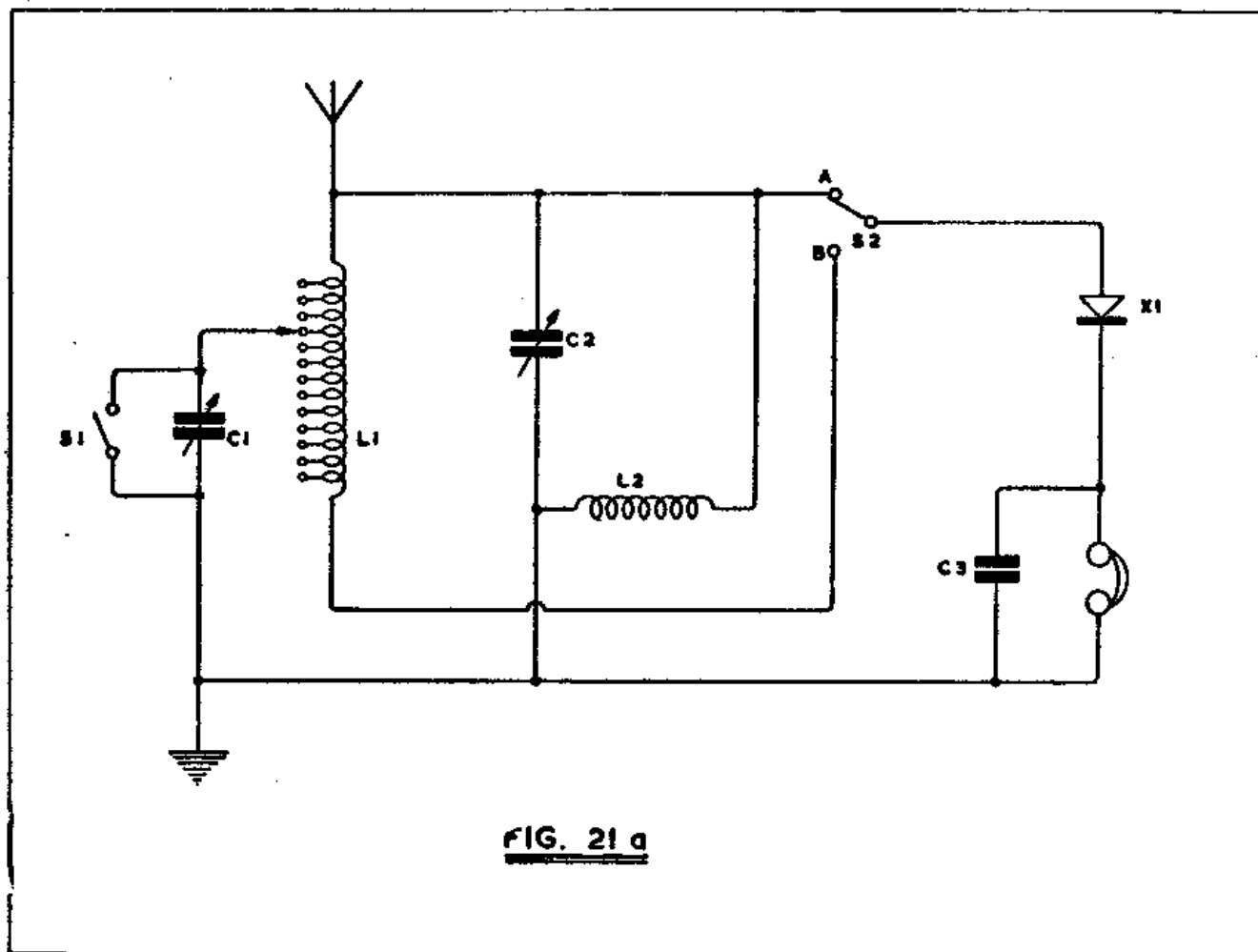

**FIG. 21 a**



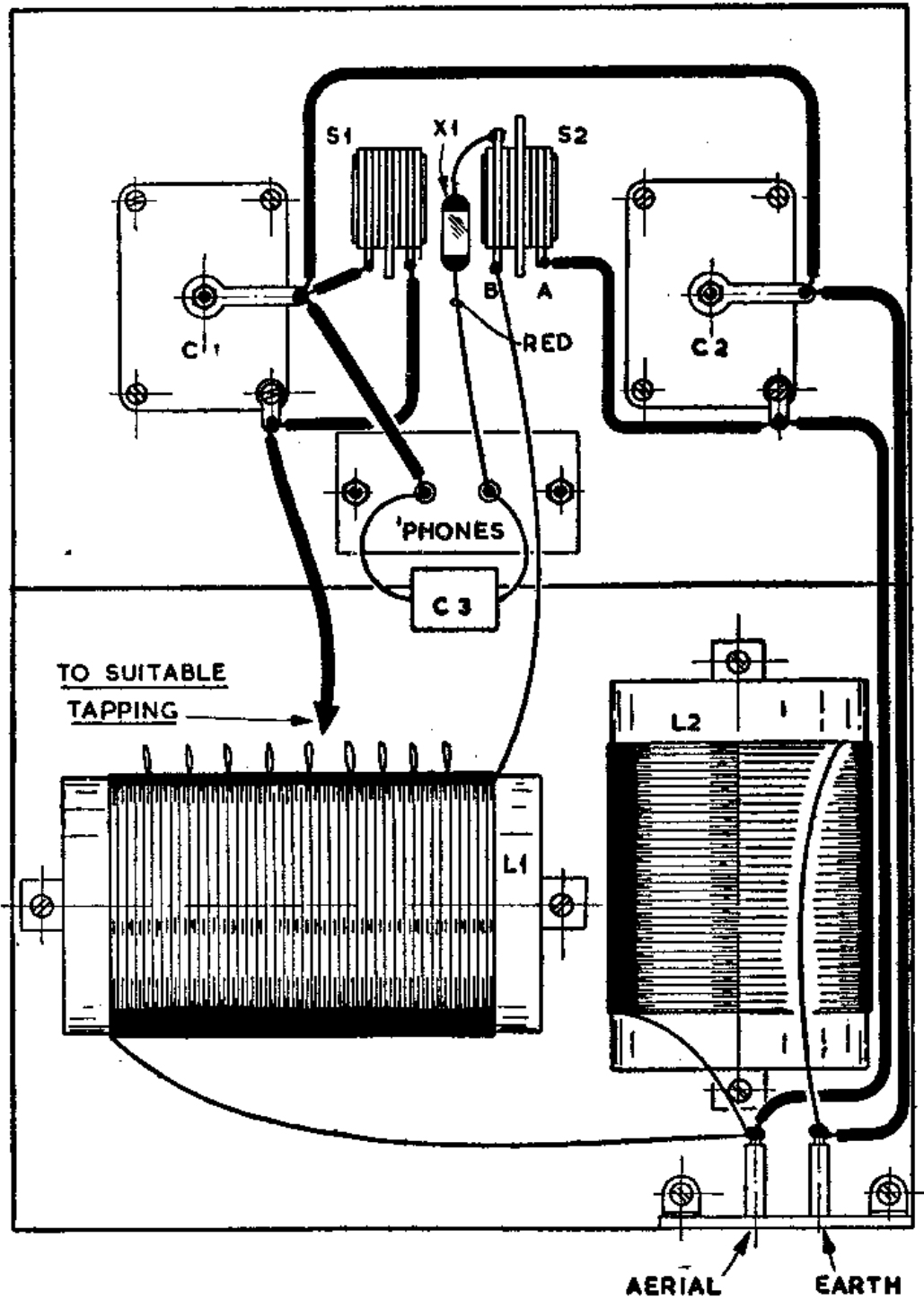

FIG. 21 b



Keep S1 open and C1 for tuning, adjusting the tap on L1 for best results. Very powerful signals are best brought in with S1 closed. When using C1 and adjusting the taps on L1, switch S2 is kept in the A position.

It will be found that C2 acts as a fine control on C1. One division of the tuning dial on C1 is

roughly equal to a movement of 20 divisions on C2.

Note that the coils are mounted at right angles to one another and that in this instance wood has been used as far as possible, an aluminium or other metal chassis is not suitable.

7

A very useful receiver for both medium and long-wave reception is possible with the circuit of Fig. 22a-b. A home-made coil is used. On the original a 1 1/4" diameter former was used but in fact this is not very critical and a 1 1/2" former could be used. An interesting point is the construction of the long-wave coil section. Solenoid coils as used for the medium wave-band are not efficient if the length is too great relative to the diameter. Now as the long-wave section has 300 turns, if wound as a solenoid the winding length would be very great and a lot of efficiency would be lost. To overcome the difficulty the coil is pile wound. If the whole coil were to be wound

in one pile it would still be inefficient because of the capacity formed in the winding, but by dividing it into five sections a coil of reasonable efficiency results. The same remarks concerning winding apply to this coil as to all the others in

Components List, Fig. 22a

- C1 300pF Mica Capacitor.
- C2 500pF Variable Capacitor.
- C3 1000 Mica Capacitor.
- X1 Germanium Crystal.
- L1-2 See Text.
- S1 Single Pole Toggle Switch.

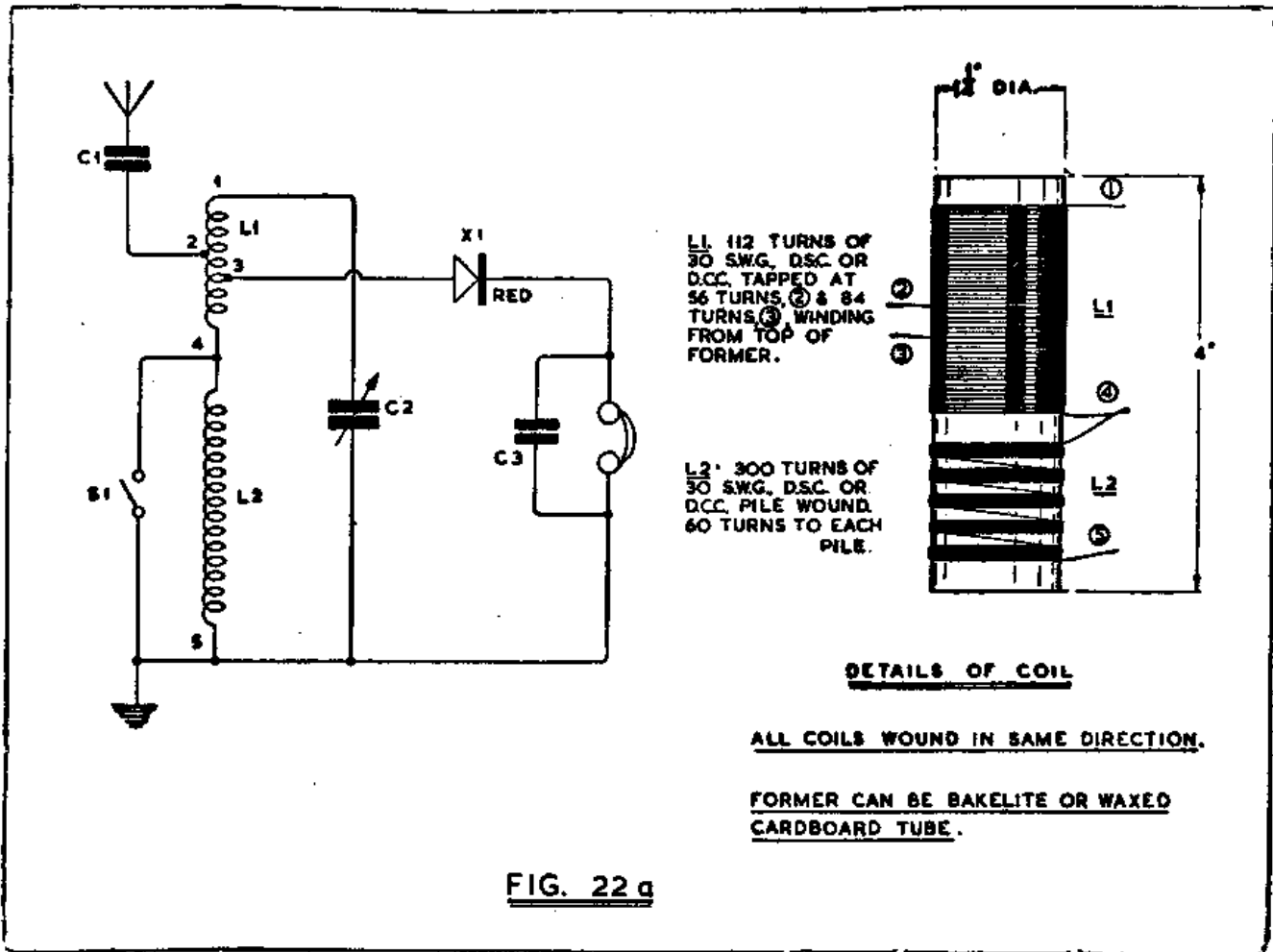



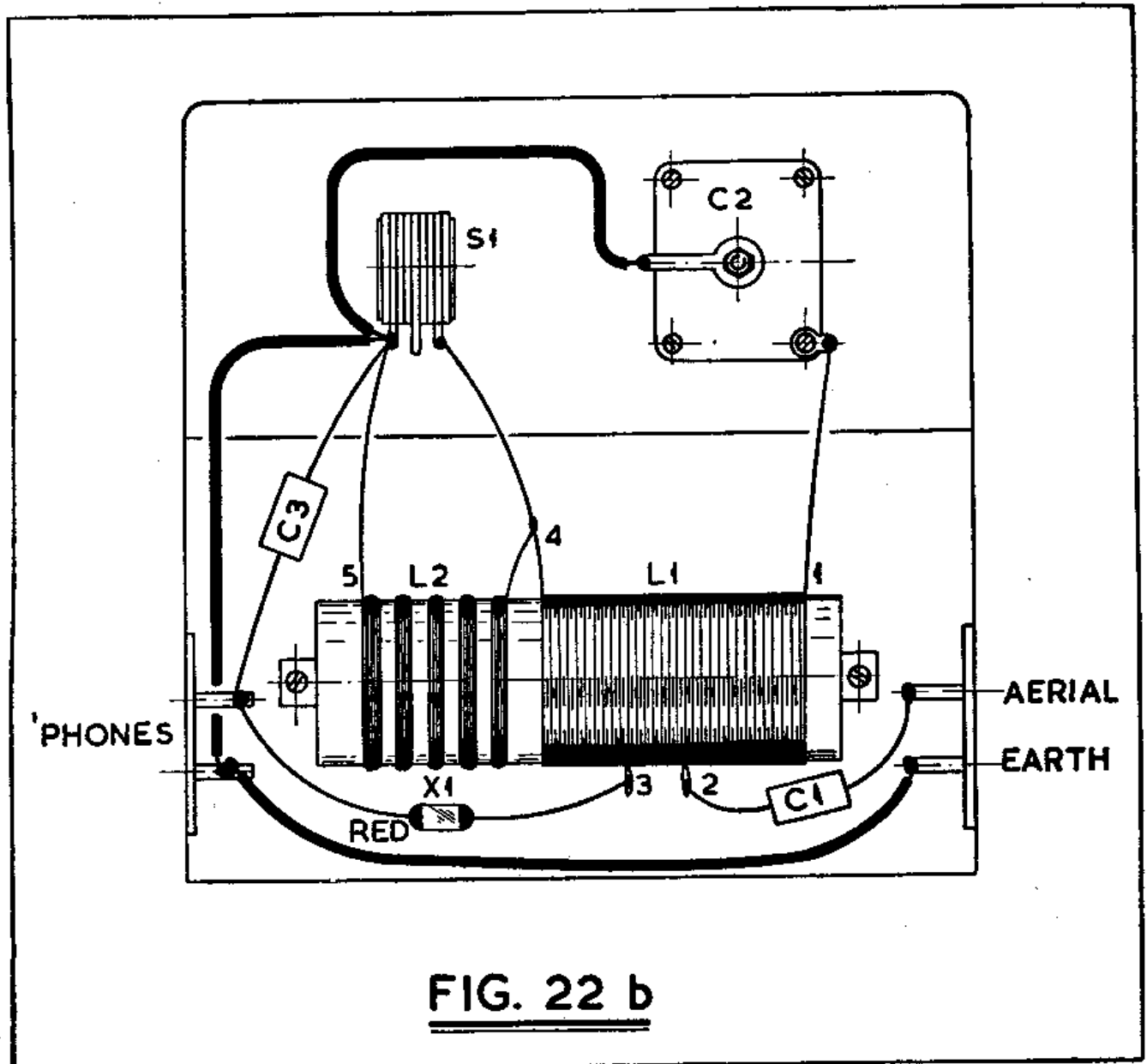

**FIG. 22 b**

this book, and readers should not, by this time, encounter any difficulties.

The design provides good selectivity with good sensitivity, and provided the set is not required to operate within a few miles of a powerful transmitter, no trouble will be encountered from interference between adjacent stations.

A wooden base-board and front panel is best for this design, and the wiring and layout can be clearly followed from Fig. 22b. Switch S1 is open for long-wave reception and closed for the medium-wave band.

Coil mounting can be on the same principle as for the full-wave design Fig. 19a-b.

8

If you look at all the other circuits shown in this book you will find that in each case the tuning capacitor and tuning coil are in parallel, this is by no means essential and the circuit of Fig. 23a shows a series arrangement that is the tuning capacitor is between the coil and earth instead of being wired up across it. This design

also appeared in *Radio Craft* a few years ago.

An interesting point is that the coil is a conversion adapted from another type of component. To make this coil you must obtain an old I.F. transformer as used in superheterodyne receivers.

You will require one designed to work anywhere between 450 and 470 kc/s. Some of the



very early ones worked at 110 kcs/ but these are unsuitable.

The I.F. transformer must also be of the type tuned by an iron dust core at each end.

Dismantle the transformer, remove the parallel capacitors and mounting wires so that you are left with two coil bobbins and their former. Be very careful when un-soldering the wires from the supports because the coils are usually wound in litzendraht and must remain intact. Remove 25% (approximately) of the turns from one coil which we will call the secondary, and completely remove the iron dust slug from this coil, now cut the former in half, and mount as in Fig. 23a. Warm the coils with heat from your soldering iron or from a fire and gently slide the coils into position at the ends of the former as in Fig. 23a. The wax will set again holding the coils in their new position.

Note that the wires from the coils are connected to tags on the mountings. These are pieces of bakelite, and usually the original end pieces used on the I.F. transformer can be used.

A word about soldering litzendraht. Do not attempt to use emery paper. Prepare the end of wire by removing the outer silk covering and dip the end in methylated spirits. Ignite with a match

and after about five seconds wipe with a cloth held between finger and thumb. This will quench the flame and will remove all traces of enamel from the wire. It is a good plan to experiment with the odd length of wire removed from the secondary coil. If the coils prove to be constructed of ordinary copper wire, it can of course be prepared with fine emery cloth in the normal manner.

**Components List, Fig. 23a**

- C1 500pF variable capacitor.
- X1 Germanium Crystal.
- L1 See Text.
- 4 Plugs and sockets or terminals.

Wiring is straight forward as can be seen from Fig. 23b and requires no explanation.

Operation is as follows, selectivity is controlled by varying the distance between coils with the wing nut, and to an extent by the position of the primary iron dust core. Remember that the aerial and earth installations are as important with this set as with any other crystal receiver. No parallel capacitance appears necessary across the 'phones, the set works quite happily relying on the self-capacitance of the head-phones.

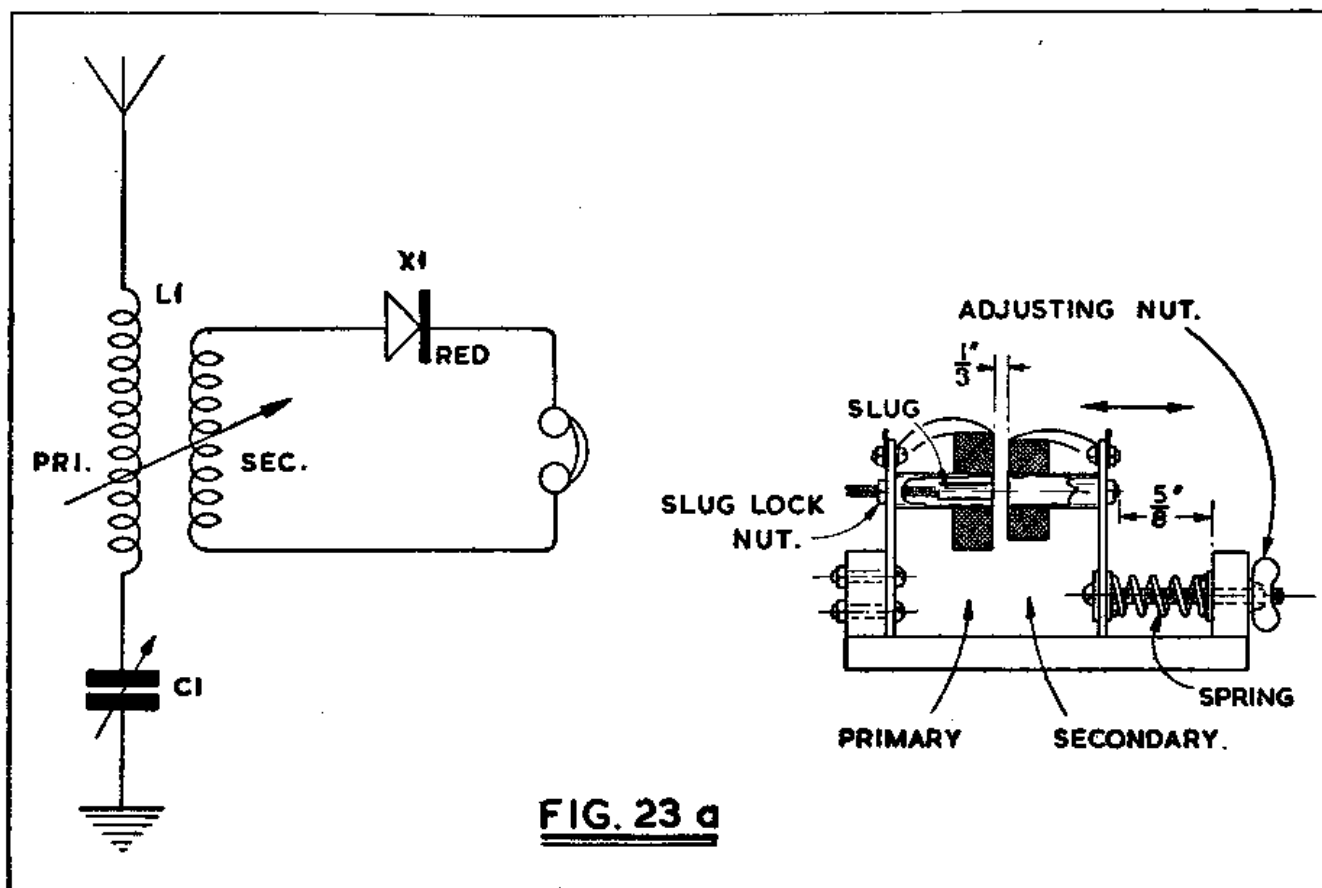

**FIG. 23 a**



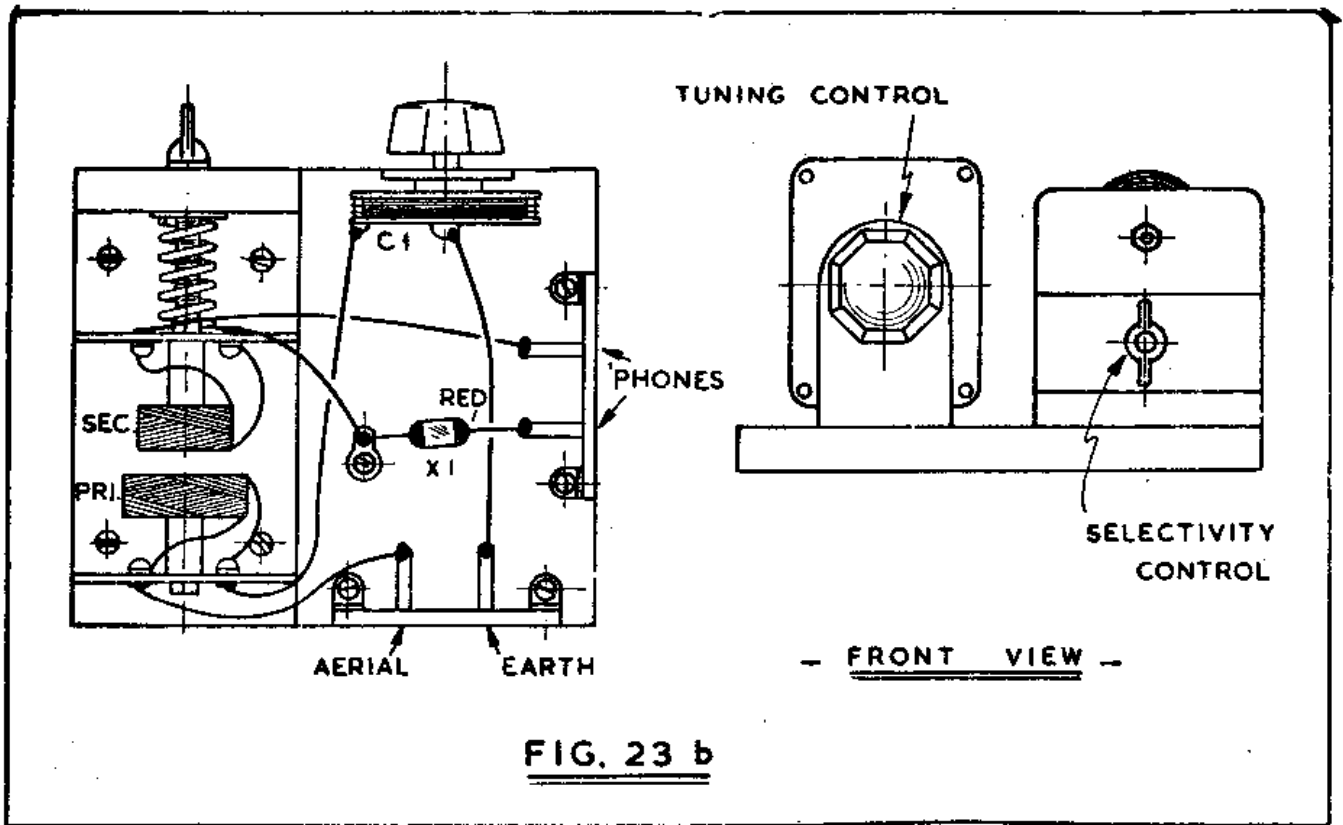

FIG. 23 b

9

So as to give a truly varied selection of circuits, some of the sets have been designed around commercial coils whilst others use coils which must be home-constructed.

Most enthusiasts like to build their own coils but when it is a question of something really small combined with efficiency a commercial coil is the obvious choice.

Fig. 24a-b uses a tobacco tin or a similar container just as the design shown in Fig. 16a.

This receiver however is a little more selective and is more suitable than the earlier design, if you are near a transmitter or have a very long aerial. Take great care to connect the coil according to the colours shown on the diagrams. Sockets are used for wave-changing, this cheapens the cost a little and they are just as efficient.

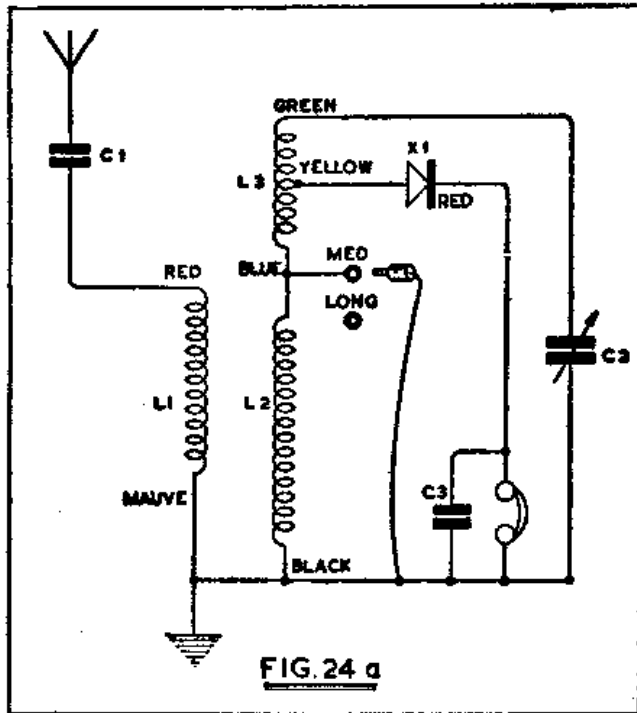
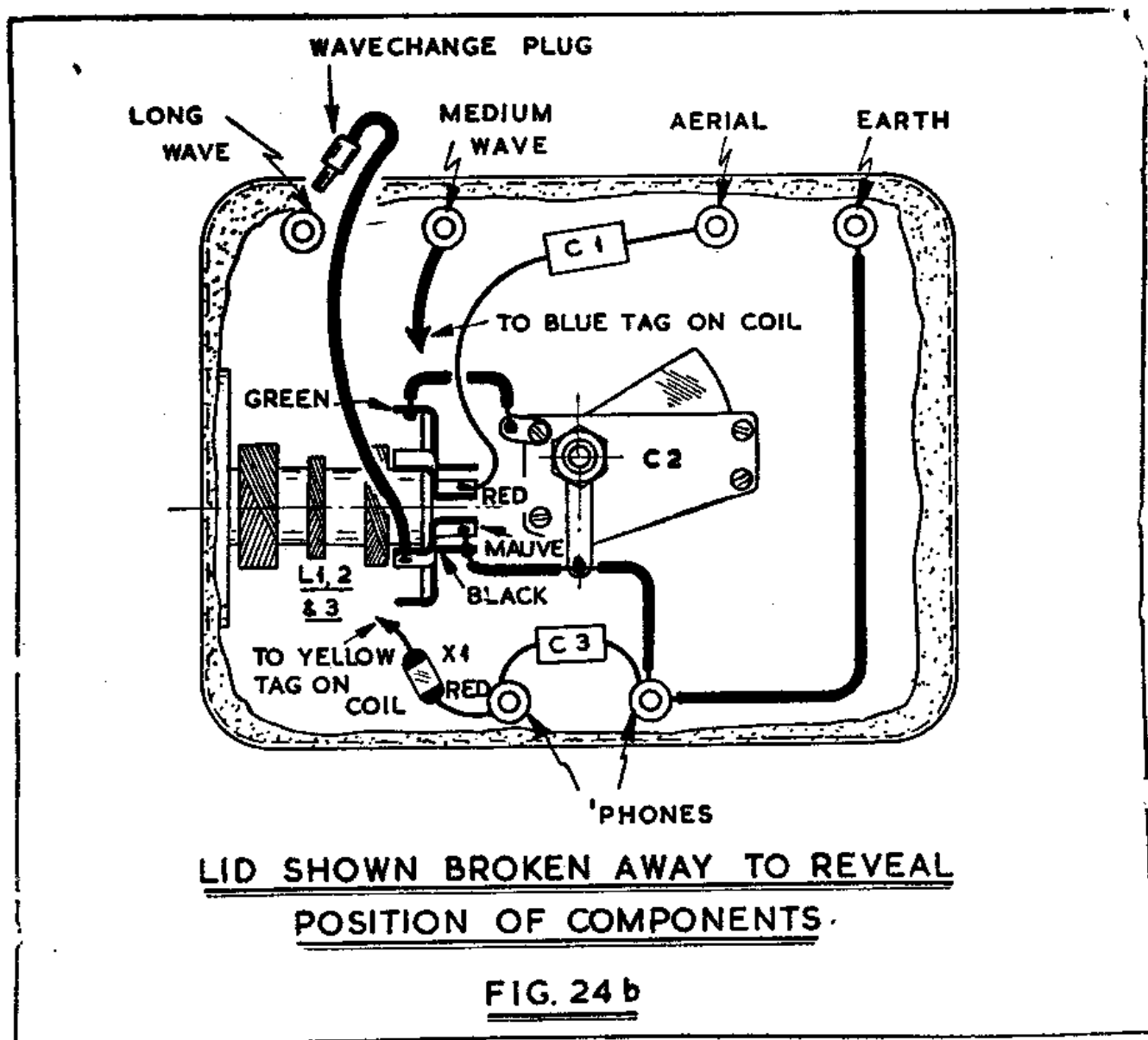

FIG. 24 a

**Components List, Fig. 24a**

- C1 100pF Mica capacitor.
- C2 500pF variable capacitor solid dielectric.
- C3 1000pF Mica capacitor.
- X1 Germanium crystal.
- L1-2 R.E.P. dual range coil. Blue box.
- 6 Insulated wander-plug sockets.
- 5 Wander Plugs.
- 2oz. Tobacco tin or similar container.



10

In certain cases, signals from the local transmitter are too powerful to permit a crystal set with a normal coil to be of much use. I myself live in Hertfordshire a few miles from the London transmitters, and find a more elaborate circuit is necessary. Now in radio circles it is a well-known fact that the greater the number of tuned circuits, the greater the overall selectivity. Look at Fig. 25a, you will see that the usual L and C tuning arrangements have been duplicated. This type of circuit is known as a Band-Pass Filter. There are many kinds of such filters, this particular type is an inductively-coupled filter, note that energy from the first half (L2) is con-

veyed to L3 by way of two small inductors L1 and L4.

Tuning is quite sharp and the "feel" of the set is quite different from that of single coil designs. A small chassis is ideal for construction.

6"x4"x2½" was used on the original, though it could have been smaller.

Fig. 25b gives the layout and wiring.

Take particular notice that L1-2-3 is mounted horizontally and at right angles to L4-5-6, this is to prevent the coupling from being too "tight" which would ruin the idea of the filter. A good aerial and earth is of course necessary. It may be found on test that the selectivity is too great



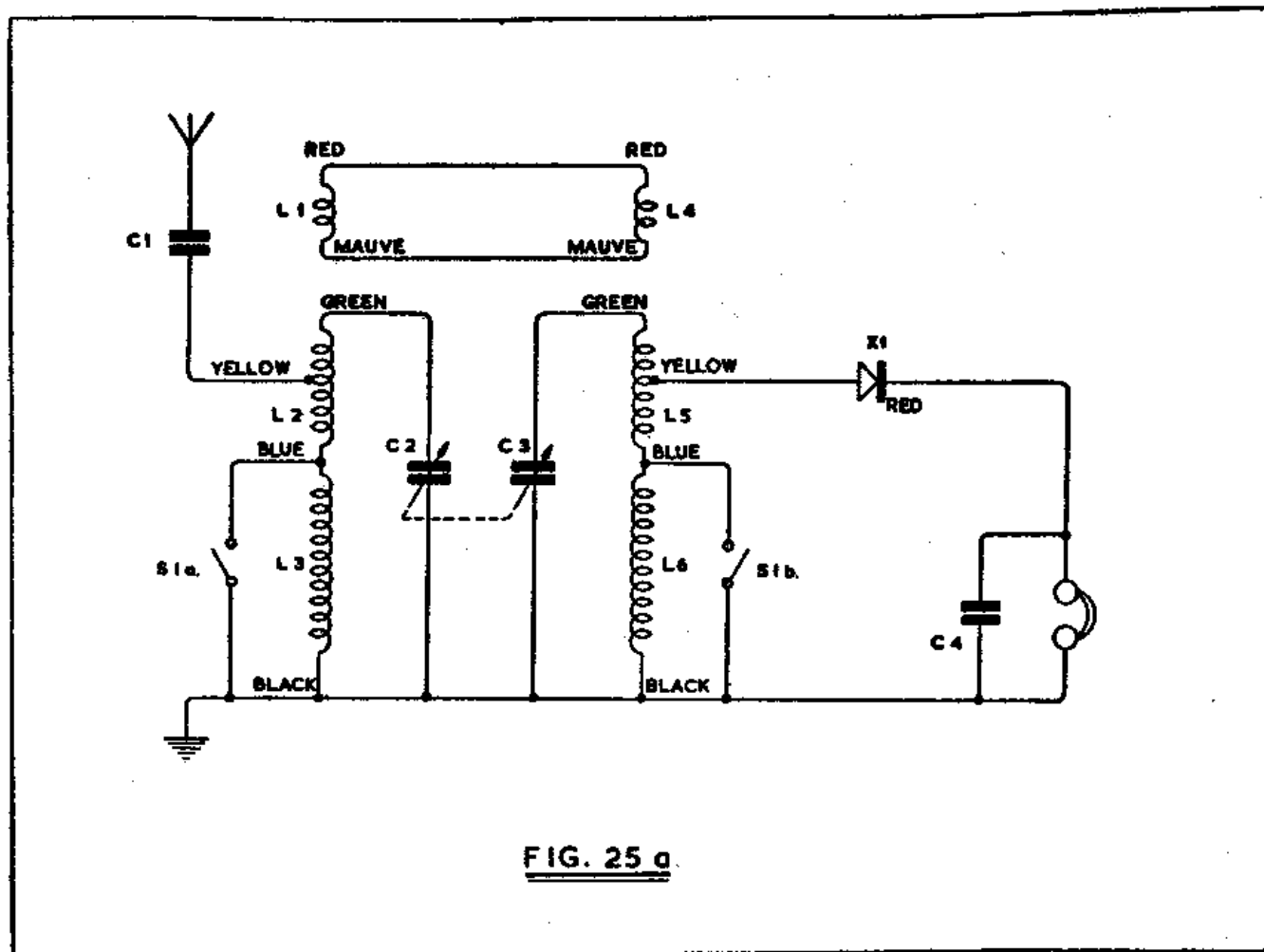

FIG. 25 a

and that volume has suffered. This can be ingeniously overcome by connecting a very small capacitance between the two Green tags on the coils. The simplest way is to connect it across the fixed vane connections on C2-C3. Values for this extra capacitance are a matter for experiment usually a value between 10pF and 47pF is sufficient. A small 50pF trimmer could be used and adjusted to suit. The ideal setting is to enable powerful adjacent stations to be received just short of overlap so that as much volume as possible is obtained.

There is one point to be observed with the ganged capacitor. It should be of the type fitted with trimmers though of course, there is no reason why you should not fit them yourself. These are to allow for differences between coils to be balanced out, and consist of a small variable capacitance across each main section.

When setting up the receiver, first set each trimmer at half way and tune in a station near the high-frequency end of the band (vanes nearly out) adjust the trimmers for maximum volume. If extra coupling capacity is added as described, try adjusting them further.

Once properly set up, no further adjustment is necessary.

**Components List, Fig. 25a**

- C1 100pF Mica capacitor.
- C2-3 2 x 500pF variable capacitor (see text).
- C4 1000pF Mica capacitor.
- L1-2-3 Dual Range Coil R.E.P. (Blue Box).
- L4-5-6 Dual Range Coil R.E.P. (Blue Box).
- X1 Germanium Crystal.
- S1a-b 2 pole single throw toggle switch.
- 4 Terminals or plugs and sockets.

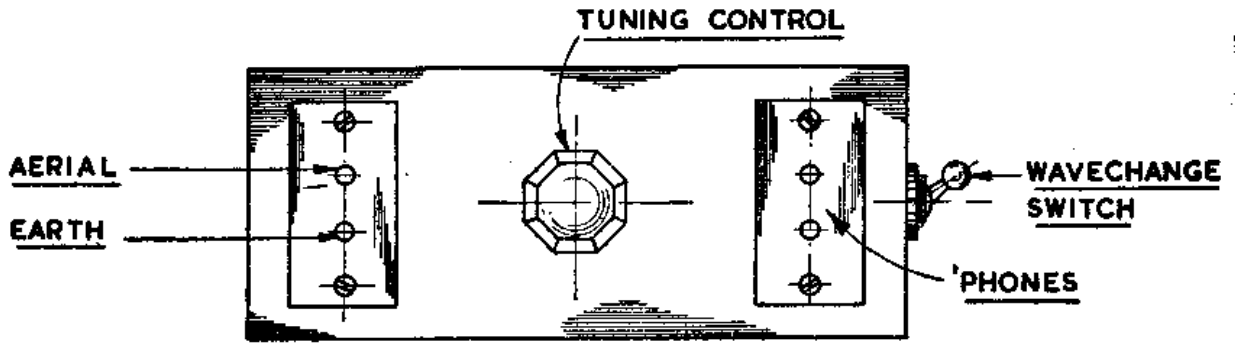

FRONT OF COMPLETED RECEIVER.

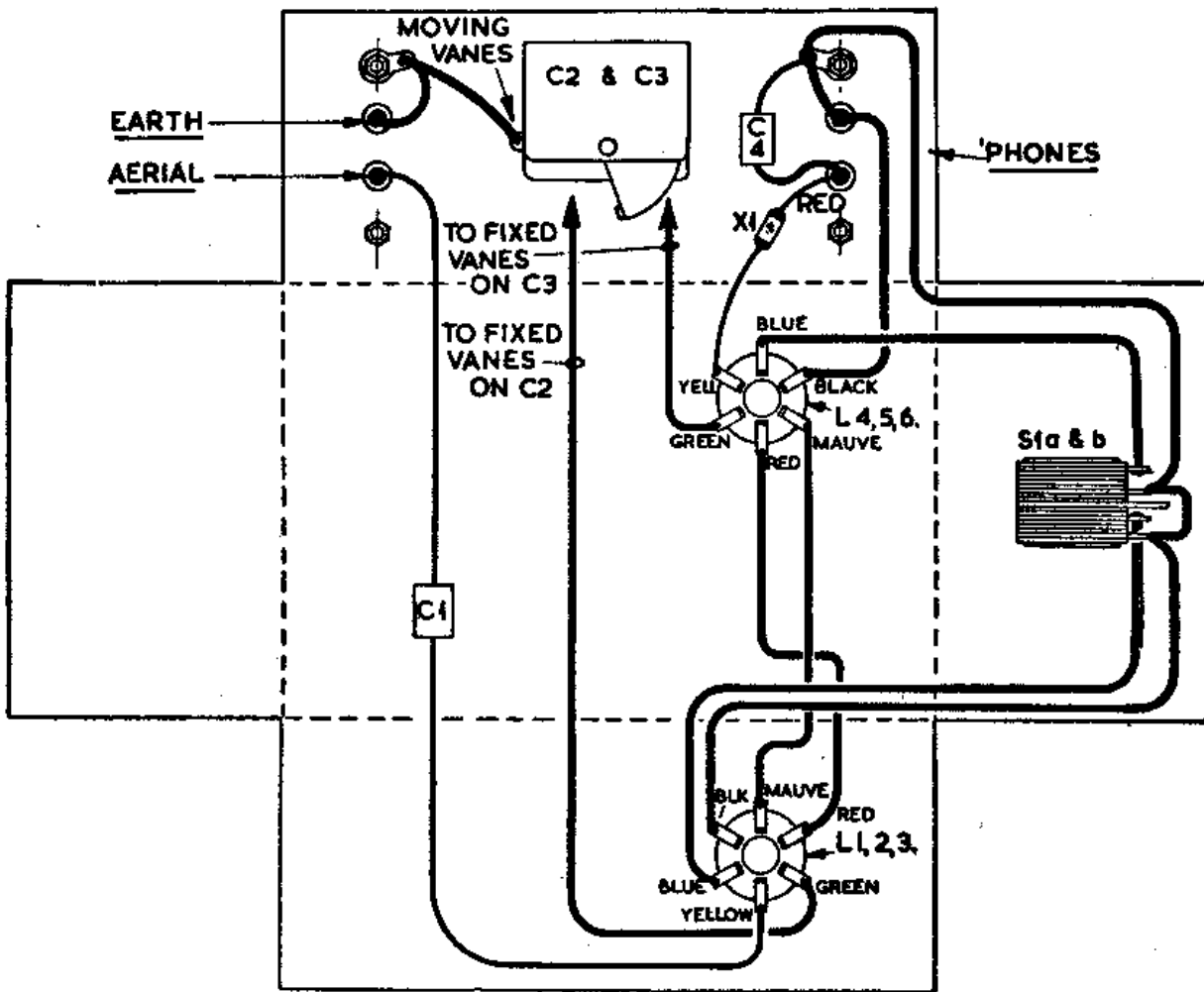

EXPLODED UNDER-CHASSIS VIEW

FIG. 25 b



## 11

Another band-pass circuit is shown in Fig. 26a. This time home-made coils are used. This filter is not inductively coupled but entirely capacitive, relying on C3. As in the previous circuit it must be adjusted to give just sufficient "broadness" to the tuning to provide adequate volume without station overlap. To avoid unwanted coupling a screen is mounted between the coils, this is necessary because due to the size of the coils they would be bound to couple quite tightly without it. Such precautions were not necessary with the circuit of Fig. 25a, as the commercial coils are much smaller physically and the risk of unwanted coupling reduced.

The coils for this receiver are for medium wave reception only, this keeps the size down. Coil winding procedure has already been fully explained, and covers all the requirements of these coils. Base-board and panel construction is used, and for more accurate tuning since the coils are home-made, separate tuning capacitors are re-

commended. Fig. 26b gives the layout and practical wiring.

## Components List, Fig. 26a

- C1 100pF Mica capacitor.
- C2 500pF variable capacitor.
- C3 50pF Mica trimmer.
- C4 500pF variable capacitor.
- C5 1000pF mica capacitor.
- L1-2 See text.
- X1 Germanium Crystal.
- 4 Terminals or plugs and sockets.

For those who do not wish to bother with these a ganged capacitor can be used, but tuning may not be as good as with separate ones. The screen mounted between the coils is of aluminium or copper and should be about 1" higher than the coils and the same length as the baseboard depth.

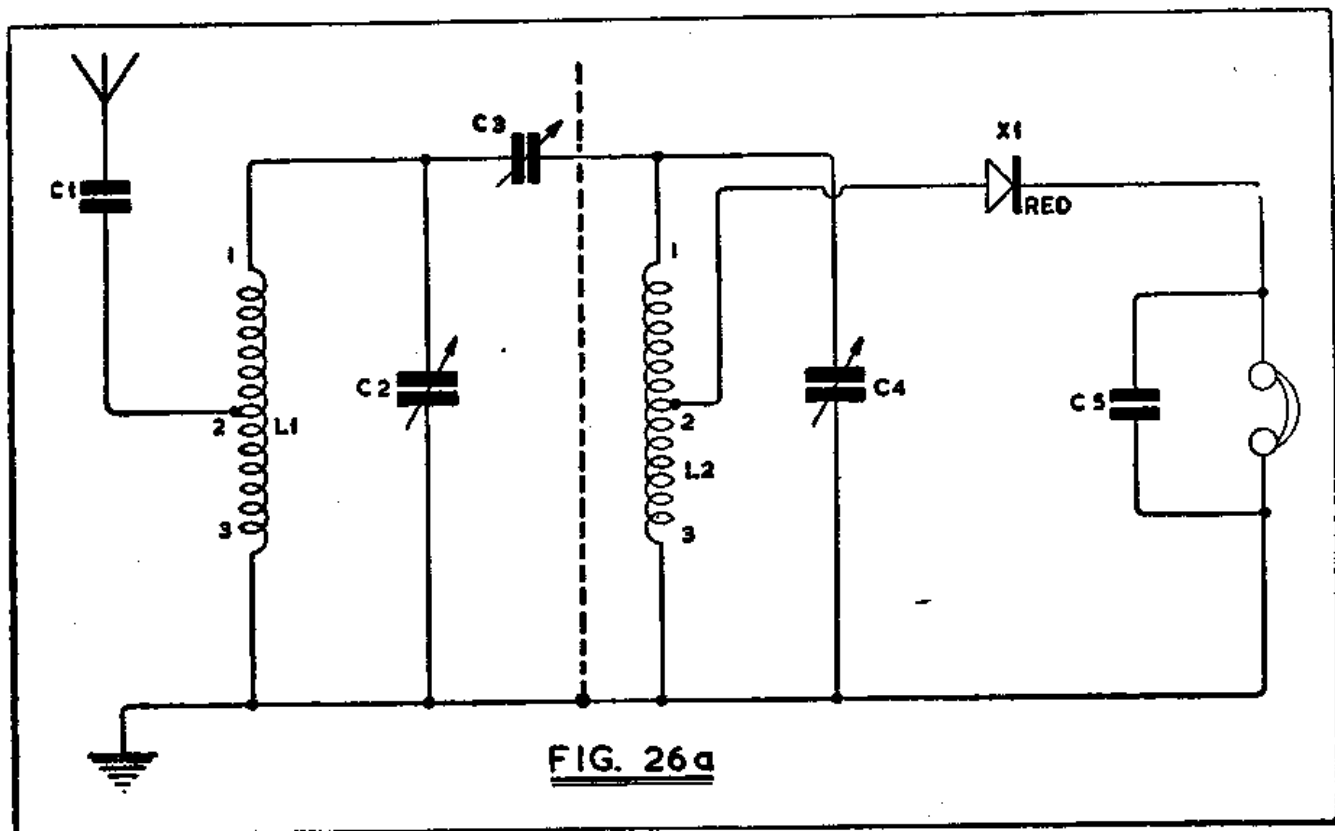
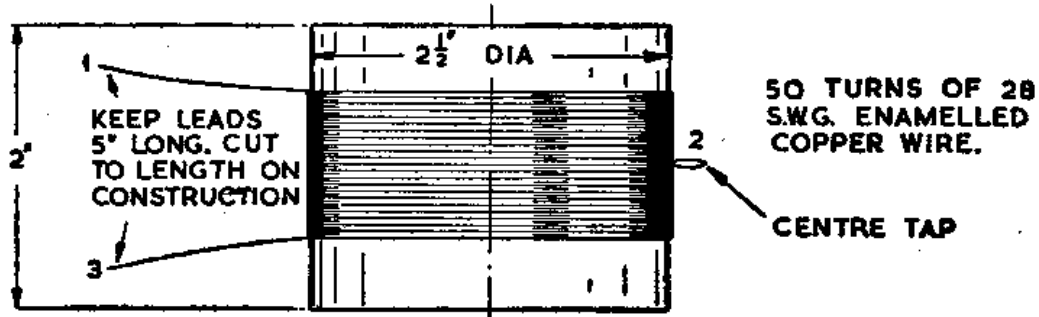

FIG. 26a



COIL DETAILS.

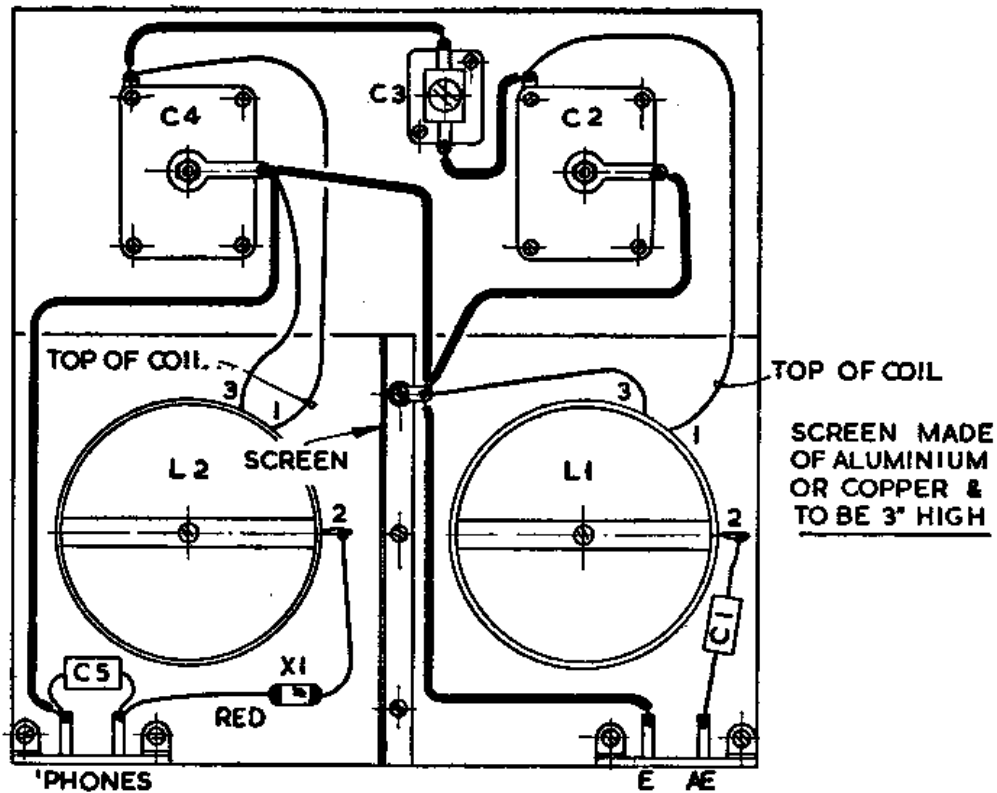

FIG. 26 b

12

Fig. 27a-b uses a band-pass filter for tuning, and the coils are home-constructed.

With this design a ganged capacitor is quite suitable as the coils tune quite accurately. It is essential that the coupling condenser C3 is non-inductive, there will be no difficulty in obtaining a new component of this pattern but it is as well to avoid old components which may not employ this form of construction.

Receivers using this type of filter are used to the best advantage when situated a short distance from a powerful transmitter and if selectivity is not important this particular design is not the most suitable.

Both medium-waves and long-waves are catered for: consider L1-2-3, this is the first half of the filter.

L1 is the aerial coupling coil, with S1 closed,



## THE BOY'S BOOK OF CRYSTAL SETS

the medium-waves are received. This coil is inductively coupled to L2 and L3. Again with S2 open L2 and L3 combined cover the long-waves and when S2 is closed the medium waves are covered.

Tuning for this half of the filter is by means of the capacitor C1, which is one half of the ganged capacitor. A screen is erected between the two sets of coils comprising the filter, and coupling is effected by C3, an earth return for the coils is provided by R1.

L4 and L5 operated in a similar manner to L2 and L3, tuning is by means of C2, the remaining section of the ganged capacitor. You will realise that the coils must be accurately wound otherwise tuning will not remain constant between the two sections over the band.

The ganged capacitor should be fitted with trimmer capacitors when purchased so that the two circuits can be balanced.

You will have noticed that this circuit uses three sets of switch contacts. A three-pole two-way wafer switch is the best choice otherwise either two or even three separate switches are

necessary. All the necessary coil details are given in the diagrams, the tap on L4 is made in the same way as shown for other coils in the manual. One other component used only on this design, is the resistor R1, its size is not important because the current flowing is so small it can be ignored.

A  $\frac{1}{2}$  watt rating is adequate, its precise value is not critical so that a 20% tolerance component is quite suitable.

Resistors are coded by colours and the 1000  $\Omega$  type you require will bear the following sequence. At one end will be painted three coloured rings.

### Components List, Fig. 27a

- C1-2 500pF 2 gang, variable capacitor.
  - C3 0.05mfd. non-inductive paper capacitor.
  - C4 1000pF mica capacitor.
  - R1 1000 ohm resistor.
  - X1 Germanium Crystal.
  - S1-2-3 3-pole 2-way wafer switch.
  - L1-2-3 & L4-5 See text.
  - 4 Terminals (Aerial, Earth and 'Phones).
- Sheet copper or aluminium for screen.

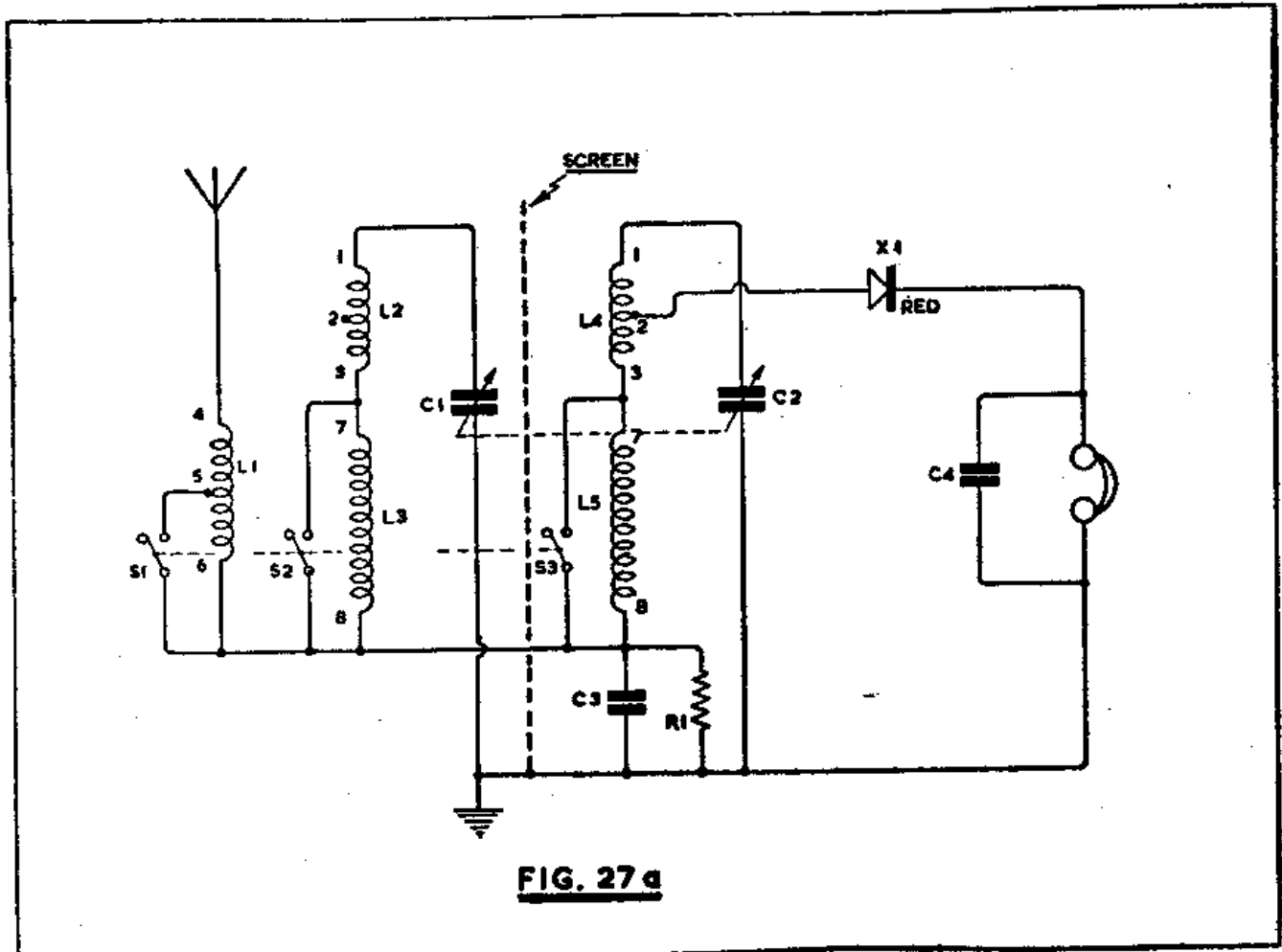
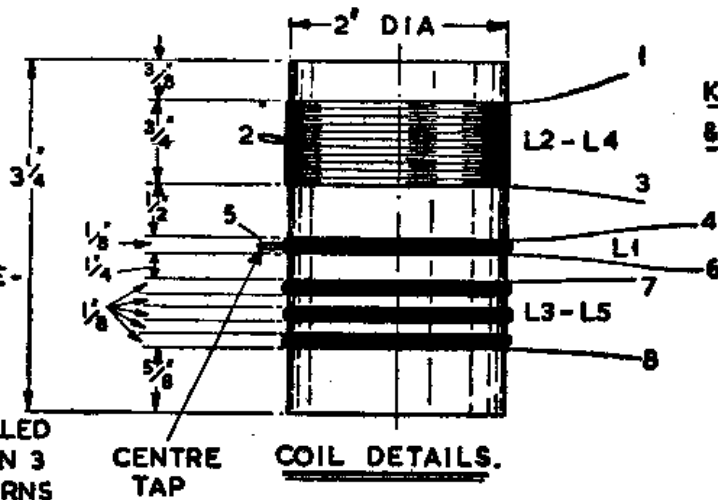

**FIG. 27 a**

**L2-L4**  
58 TURNS No.30  
SWG. ENAMELLED  
WIRE. CENTRE  
TAPPED.

**L1.** 75 TURNS  
No.36 SWG.  
ENAMELLED WIRE-  
PILE WOUND.

**L3-L5**  
174 TURNS No.  
36 SWG. ENAMELLED  
WIRE - WOUND IN 3  
PILES OF 58 TURNS



**KEEP LEADS 6" LONG  
& CUT TO LENGTH ON  
CONSTRUCTION**

**ON COIL L4 & L5,  
OMIT WINDINGS  
4 TO 6**

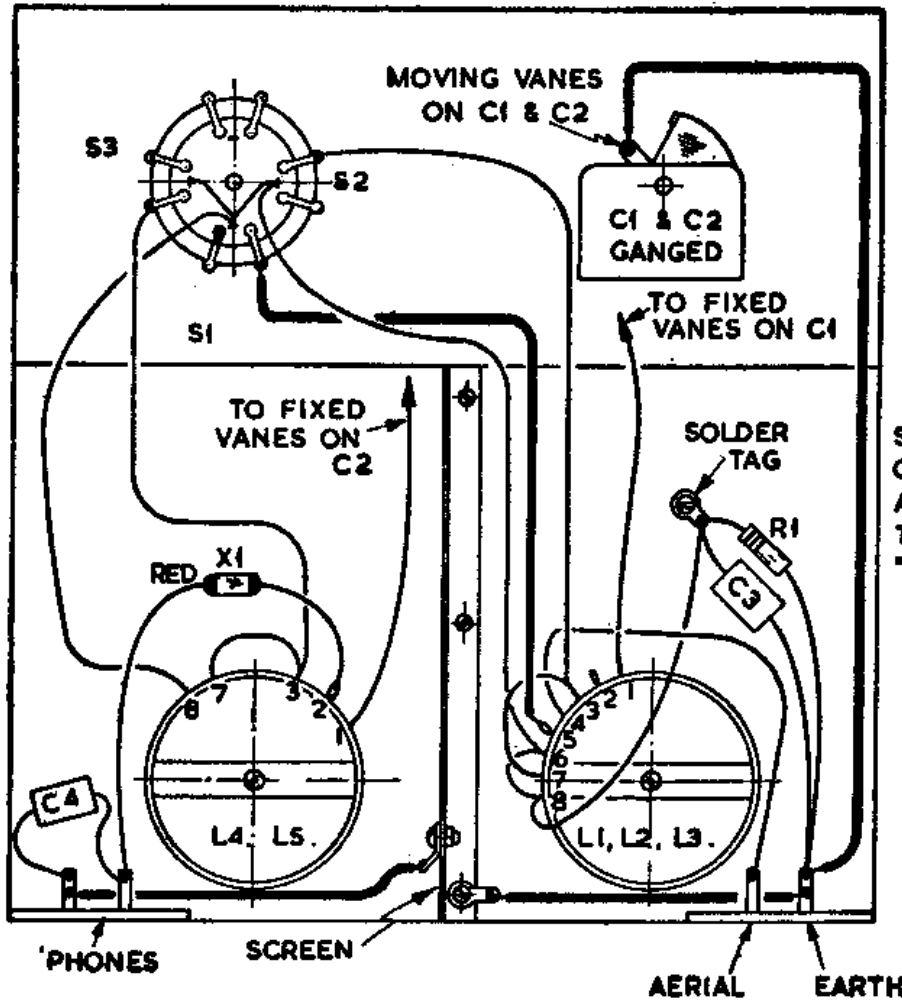

**SCREEN MADE  
OF COPPER OR  
ALUMINIUM &  
TO BE 4 1/2" HIGH.**

**FIG. 27 b**



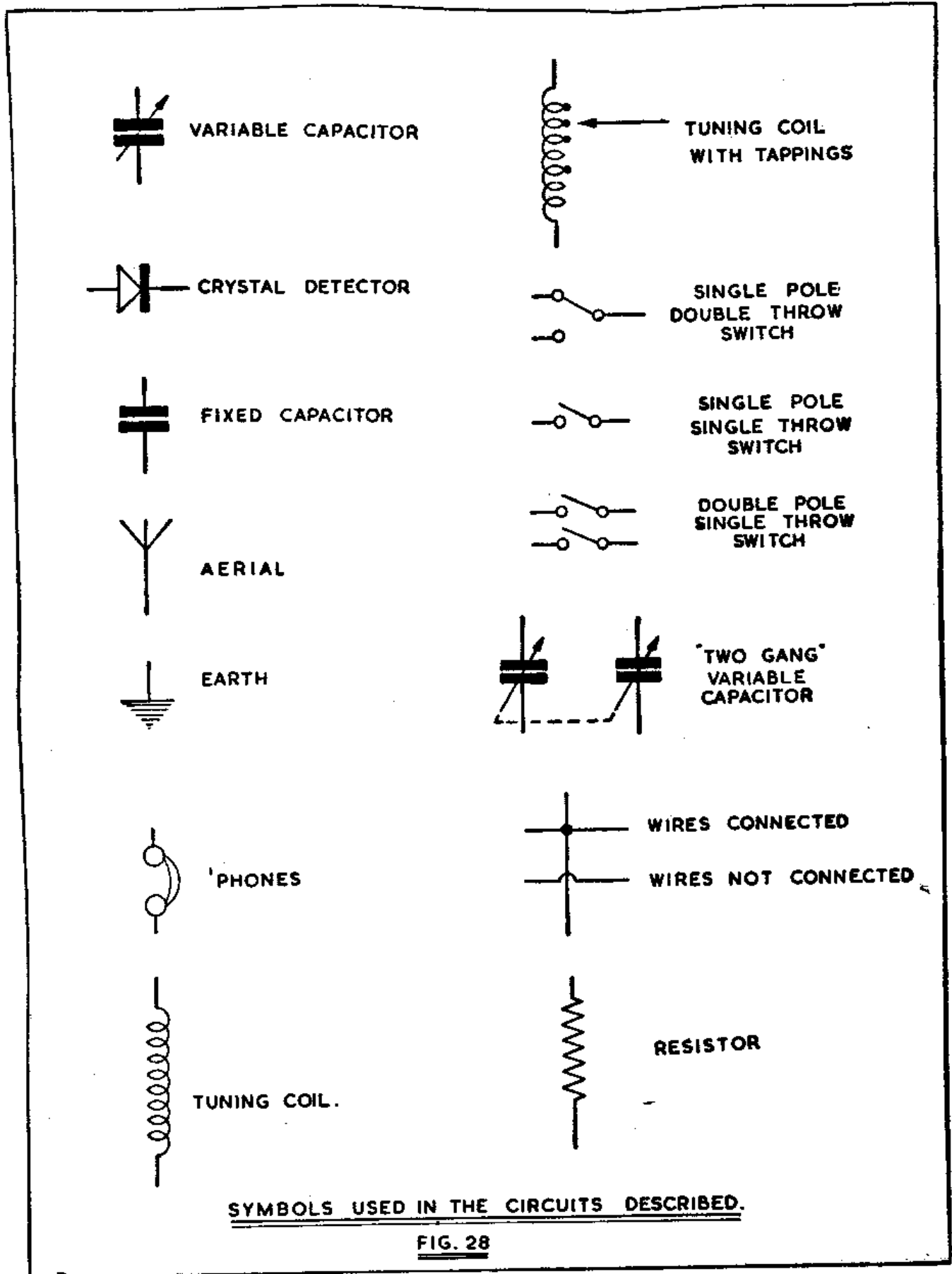

SYMBOLS USED IN THE CIRCUITS DESCRIBED.

FIG. 28

The first one is BROWN which represents 1, the first figure of the value, the second BLACK, this indicates the second numeral is nought, and the third colour is RED which tells us that two further ciphers or noughts are added to give the total value. From this you can see, we have 1 plus a nought equalling 10, plus two further noughts which total 1000. Some earlier types of resistor were painted differently, the whole body colour represented the first figure, one tip was coloured to represent the second figure, and a painted dot in the centre gave the number of ciphers to be added.

There are no other special points regarding construction except perhaps that if a long aerial is used, a small 100pF capacitor might be tried in the aerial lead to prevent damping the first uned circuit.

When setting up the receiver, tune to a station the high-frequency end of the M.W. band and the trimmers for loudest volume, no other adjustments are necessary.

## CONCLUSION

The twelve receivers described are representative of the best crystal set designs available to-day. Their construction will provide many hours of useful enjoyment, and the results will give lasting pleasure.

A final word about components, if no actual maker is specified, any good class component can be used. Switches, fixed and variable capacitors and crystals, are available from numerous manufacturers all of which are invariably of excellent quality. Where a particular manufacturer's product is called for, the specification should be adhered to. The commercial coils specified are freely available from most supply houses specialising in components for constructors, but in case of difficulty write to Bernards (Publishers) Ltd., The Grampians, Western Gate, London, W.6, who will, on receipt of a S.A.E. be pleased to supply the address of your nearest stockist. Coil formers are not always easy to obtain and in this case advice should be sought from Post Radio Supplies, 395, Queensbridge Road, London, E.8, who will be pleased to help in any way possible.





# BERNARDS RADIO BOOKS

No.		Price
56.	Radio Aerial Handbook ... ..	2/6
57.	Ultra-Shortwave Handbook ... ..	2/6
58.	Radio Hints Manual ... ..	2/6
64.	Sound Equipment Manual ... ..	2/6
68.	Frequency Modulation Receivers' Manual ... ..	2/6
83.	Radio Instruments and their Construction ... ..	2/6
96.	Crystal Set Construction ... ..	1/-
99.	One Valve Receivers ... ..	1/6
100.	A Comprehensive Radio Valve Guide, Book 1 ... ..	5/-
103.	"Radiofolder" A. The Master Colour Code Index for Radio and T.V. ... ..	1/6
104.	Three Valve Receivers ... ..	1/6
121.	A Comprehensive Radio Valve Guide, Book 2 ... ..	5/-
123.	"Radiofolder" F. The Beginners' Push-Pull Amplifier ... ..	1/6
126.	Boys' Book of Crystal Sets and Simple Circuits ... ..	2/6
129.	Universal Gram Motor Speed Indicator ... ..	1/-
135.	All Dry Battery Portable Construction ... ..	2/6
138.	How to Make F.M. and T.V. Aerials, Bands 1, 2 and 3 ... ..	2/6
141.	Radio Servicing for Amateurs ... ..	3/6
143.	A Comprehensive Radio Valve Guide, Book 3 ... ..	5/-
145.	Handbook of AM/FM Circuits and Components ... ..	2/-
146.	High Fidelity Loudspeaker Enclosures ... ..	5/-
147.	Practical Tape Recording Handbook ... ..	5/-
148.	Practical Transistor Receivers, Book 1 ... ..	5/-
149.	Practical Stereo Handbook ... ..	3/6
150.	Practical Radio Inside Out ... ..	3/6
151.	Transistor Superhet Receivers ... ..	7/6
156.	Transistor Circuits Manual, No. 1 ... ..	2/6
157.	A Comprehensive Radio Valve Guide, Book 4 ... ..	5/-
158.	Radio, Television, Industrial Tubes, Semiconductor and Diodes Equivalents Handbook (208 pages) ... ..	9/6
159.	Realistic High Fidelity ... ..	5/-
160.	Coil Design and Construction Manual ... ..	5/-
161.	Radio, Television and Electronics Data Manual ... ..	3/6
162.	High Fidelity Stereo Gramophone ... ..	5/-
163.	Transistor Circuits Manual, No. 2 ... ..	2/6
165.	Hartley on Hi-Fi, Book 1. Radio Tuners ... ..	5/-
166.	Public Address Systems ... ..	2/6
168.	Transistor Circuits Manual, No. 4 ... ..	2/6
170.	Transistor Circuits for Radio Controlled Models ... ..	7/6
171.	Super Sensitive Transistorised Pocket Set Construction ... ..	3/6
172.	International Radio Stations List ... ..	2/6
173.	Practical Transistor Audio Amplifiers ... ..	3/6
174.	Transistor Subminiature Receivers Handbook ... ..	5/-
175.	Transistorised Test Equipment and Servicing Manual ... ..	3/6
176.	Transistor Audio Amplifiers Manual ... ..	6/-
177.	Modern Transistor Circuits for Beginners ... ..	7/6
178.	Comprehensive Radio Valve Guide Book 5 ... ..	6/-
179.	Transistor Circuits Manual No. 5 ... ..	5/-
180.	British Semiconductor Survey ... ..	15/-
181.	22 Tested Circuits Using Micro Alloy Transistors ... ..	5/-
182.	"At A Glance" Radio Valve & T.V. Tube Equivalents ... ..	3/6
183.	How to Receive Foreign T.V. Programmes on your Television Set by simple Modifications ... ..	5/-
184.	Tested Transistor Circuits Handbook... ..	2/6
185.	Tested Short-Wave Receiver Circuits using Micro Alloy Transistors (MAT's) ... ..	5/-
186.	Tested Superhet Circuits for Short-Wave and Communication Receivers using Micro Alloy Transistors (MAT's) ... ..	6/-
187.	The TSL Mark "4" Valved F.M. Tuner and its Construction ... ..	3/6
188.	Construction of the B.H. High Fidelity "14" watt Audio Amplifier ... ..	1/6
189.	How to build the world's smallest transistor radio. The Sinclair Micro 6 ... ..	1/-
190.	How to build the world's smallest High Fidelity Amplifier ... ..	1/6
191.	Practical Car Radio Handbook ... ..	6/-
501.	ABC's of Magnetism ... ..	5/-
502.	ABC's of Missile Guidance ... ..	5/-
503.	ABC's of Ultrasonics ... ..	5/-
504.	ABC's of Transistors ... ..	5/-
	Resistor Colour Code Disc Calculator ... ..	1/6
	Engineers' Reference Tables ... ..	1/6
	International Radio Tube Encyclopaedia—3rd Edition ... ..	63/-



# A Crystal Set for the Boy Builder

By WILL H. BATES

THIS little set is recommended for the boy builder, although the grown-ups also will enjoy it. Exclusive of the phones, the cost should not exceed \$1. Surprising volume is obtained on the local stations, and the set is more selective than the average receiver of this type.

Very few parts are required. The wood base may be made of scrap material found around the home. The other items can be bought at the 10-cent store, with the exception of the crystal holder. For this, an upright type, as illustrated, should be

coat of mahogany or walnut stain. Drill it for the four binding posts, which are located as shown in the illustration of the under side of the base. A  $\frac{1}{2}$ -in. bit is used to countersink these holes halfway through the board from below.

The spiderweb coil is wound on the form shown in the diagram; this form may be cut from fiber or cardboard, and the dimensions should be followed. The thirteen spokes are  $1\frac{1}{4}$  in. long, leaving an uncut center  $2\frac{1}{2}$  in. in diameter. Wind the turns of No. 24 d.c.c. magnet wire alter-

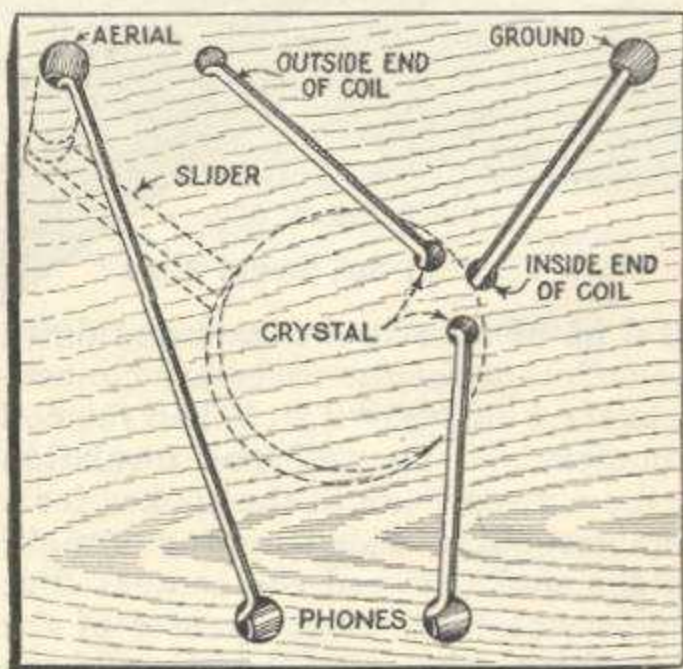
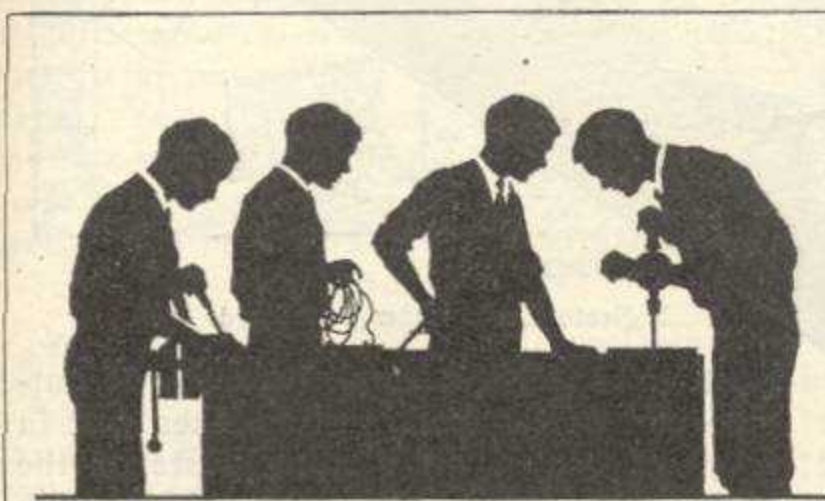

WIRING ON UNDER SIDE OF BASE

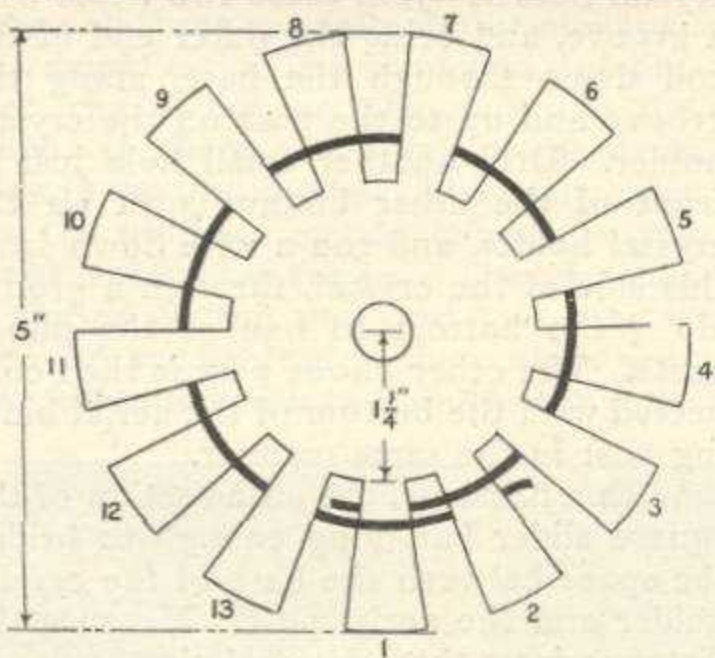

Left, Construction Details of Coil Form; Black Line Shows Method of Winding; Insert at Right, Schematic Circuit Diagram

selected, and may be obtained for about 25 cents. A good pair of 2,000-ohm phones should be used and these are available for about \$2.50.

The base may be beveled on the top edges, sanded down, and then given a

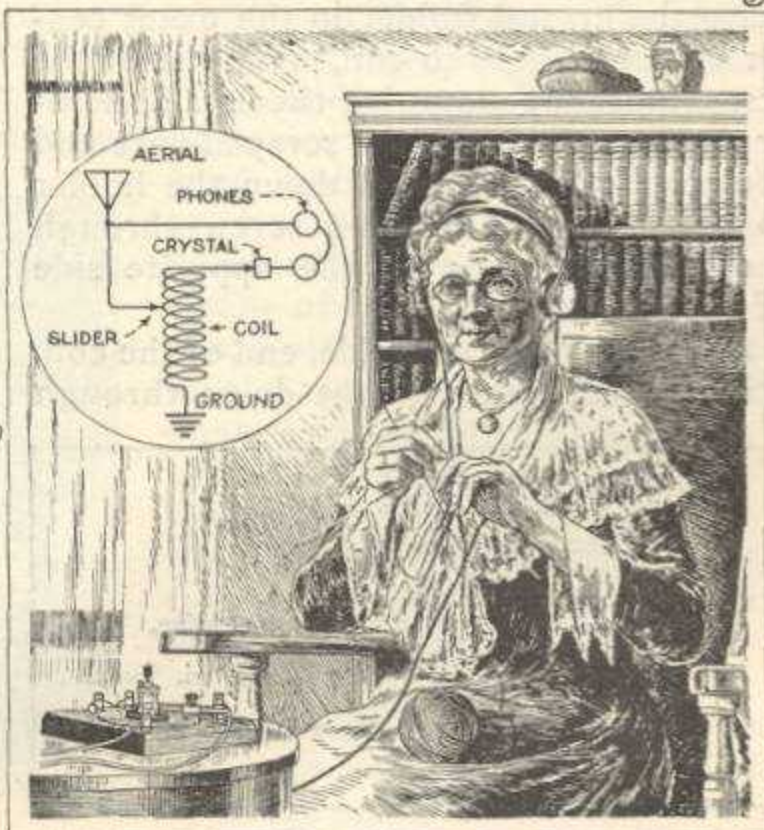



nately over and under the spokes, as indicated by the heavy line. When doing this keep count of the turns by marking one spoke and counting one each time this is passed. Fifty turns are required. Leave

the base, and on the under side, cut a groove in a straight line from this hole to the ground binding post. Run the inside end of the wire down through this hole and along the groove to the ground

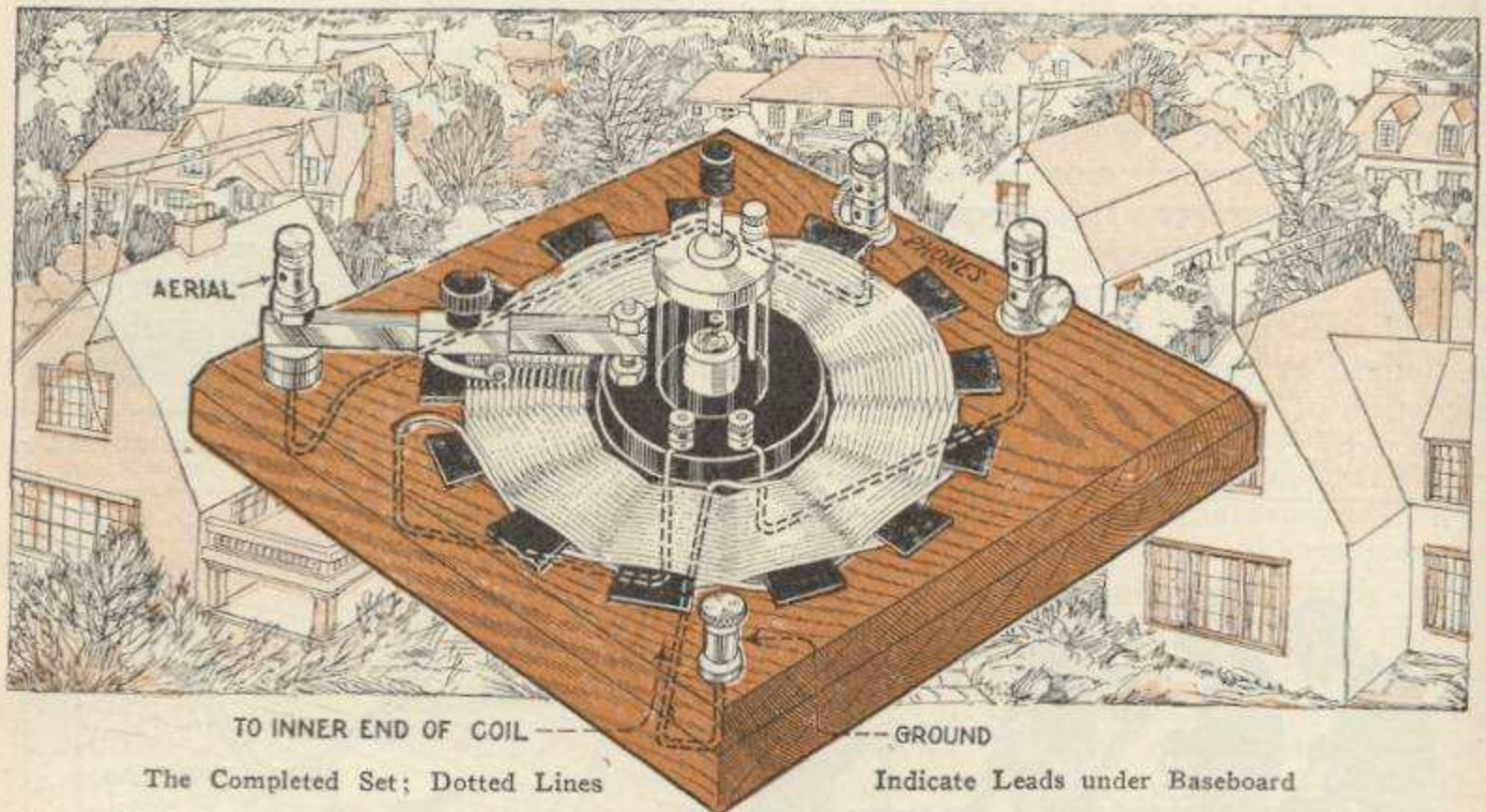

about 6 in. of wire at the start and finish of the coil, to make the necessary connections to the binding posts. When the coil is completed, scrape off the insulation from the wires on one of the spokes for a space about  $\frac{1}{4}$  in. wide, running straight down the spoke toward the center. Put the spiderweb form on the center of the baseboard with the scraped section of the wire pointing to the aerial post. Then place the crystal holder in the exact center of the spiderweb coil, with one of the screw holes for mounting the crystal holder in direct line with the scraped wire and the aerial post. Fasten down the holder to the base with a wood screw through the mounting hole on the opposite side of the crystal holder.

At the starting, or inside, end of the coil, drill a small hole straight down through

post. Also drill a small hole at the outside end of the coil, and another just in front of one of the binding posts on the crystal holder. Join these two holes with a groove, and bring the outer end of the coil down through the base, along the groove and up to the post on the crystal holder. Drill another small hole just in front of the other binding post on the crystal holder, and run a wire down from this side of the crystal, through a groove along the bottom to one of the phone posts. The other phone post is then connected with the bottom of the aerial binding post in the same manner.

With a hacksaw, cut off a section of the square slider bar, long enough to bridge the space between the base of the crystal holder and the aerial post. Measure the distance from the screw hole in the flange of the crystal-holder base to the aerial post, and drill holes in the slider bar accordingly. A 6-32 brass machine screw,  $1\frac{1}{2}$  in. long, is brought up through the baseboard, and through the opening in the flange. This hole is drilled down through the flange, using the hole in the crystal holder as a template. The hole on the under side of the base is countersunk for the head of this screw, which is

#### MATERIAL LIST

- 1 wood base,  $\frac{3}{4}$  by 6 by 6 in.
- 4 binding posts.
- 1 spiderweb form.
- 1 small spool No. 24 d.c.c. magnet wire.
- 1 slider bar, 3 in. long, with slider.
- 2 6-32 brass machine screws,  $1\frac{1}{4}$  in. long.
- 1 wood screw, 1 in. long.
- 1 crystal and holder, upright type.
- Washers and extra nuts.



not shown in the illustration as no circuit wires go to it. A nut is fitted on the end of the screw protruding through the holder flange above, and the slider bar slipped down on the nut, where it is held by another nut. At the aerial post, a brass machine screw of the same size is passed up through the baseboard, the lead from the phone post first being securely fastened to the head of the screw on the under side. Washers or a bushing should be used to level the bar. Put the slider on the bar and mount on the screw. The aerial binding post is then screwed down, and the set is ready for use.

To operate the receiver, use a one-wire aerial, about 75 or 80 ft. long, and connect a lead from the ground post to a clamp attached to a cold-water pipe. Then insert the phone-cord terminals in their posts. Tune by moving the slider along the bar until a station is heard at maximum volume and adjust the crystal to the spot where best results are obtained.

---



## CONSTRUCTION OF RADIO RECEIVING APPARATUS

By THE LABORATORY STAFF

**EDITOR'S NOTE:** The apparatus described in this article has been constructed and tested in the *Everyday Mechanics* Experimental Station. The author may be seen at the Publication Office of the magazine.

IN presenting the two designs embodied in this article, we do not wish to pose as originators of new types of apparatus, and neither do we wish to give the impression that the apparatus we have constructed is superior to anything on the market. The loading inductance presents no startling improvements in design or construction and the receiving transformer is just a good, substantial piece of apparatus that an advanced amateur need not be ashamed to construct and operate.

What we have endeavored to do, however, is this: We have tried to eliminate the defects, principally mechanical, that seem inherent in amateur apparatus; we have attempted to produce a design pleasing to the eye, convenient and smooth in operation, simple and inexpensive in construction, and of correct proportions and specifications from the radio standpoint.

The old "loose coupler" type of receiving transformer has long been a favorite for the very simple reason that it gives such universal satisfaction. The writer well remembers the experience of one of the best known manufac-

tures of amateur apparatus of the better grade. For years this concern had manufactured and sold great quantities of a certain number—a comparatively simple receiving transformer with sliding contacts and telescoping primary and secondary. True, the workmanship was excellent—as it was on every number turned out by the company—but there was nothing startling about that "loose coupler" to give it such a reign of popularity. However, when the manufacturer tried to substitute a perfect wonder of a tuner, with variometer coupling and a myriad of instrument-switch contacts, offering the new and improved device at the same figure as that asked for the plebeian coupler, the trade appeared to receive the newcomer with indifference and doubt. After several years of pushing and advertising, the little tuner had to be discontinued, relinquishing the field to a revival of the old-fashioned coupler. It is an actual fact that the demand for the old favorite was greater, probably just because of its simple goodness, than that for the improved instrument which was really a much better

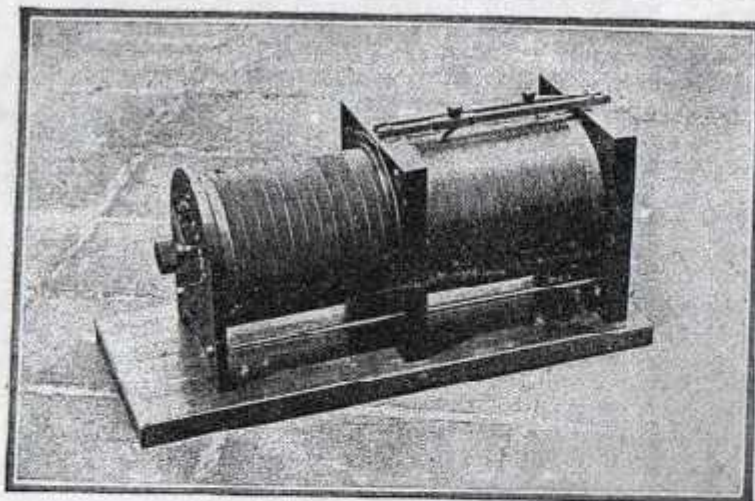

Fig. 1. Receiving transformer completed

buy, value considered, than its successful predecessor.

Perhaps the reader will wonder at this digression. It is given merely to justify the publication of the design of a type that has been described many, many times in contemporary magazines. If our readers could but see our models, turn their contact knobs, and listen in to the gratifying results obtained, this justification would be unnecessary. Whatever adverse criticism this article may bring forth, the fact remains that there are probably more of these simple receiving transformers in use, and in *successful* use, too, than there are of any or all other types.

## THE RECEIVING TRANSFORMER

This transformer has instrument switch adjustment for secondary inductance and sliding contact adjustment for the primary. The construction is such that no metal (supporting rods) is used inside either primary or secondary windings. While the deleterious effect of metal in such cases is perhaps open to question, we have avoided its use as unnecessary in our design.

The transformer responds to wave-lengths as high as 2,500 meters without the loading inductance. This is believed to be the "happy medium" which reduces objectionable "dead ends" to a minimum and still affords a wave-



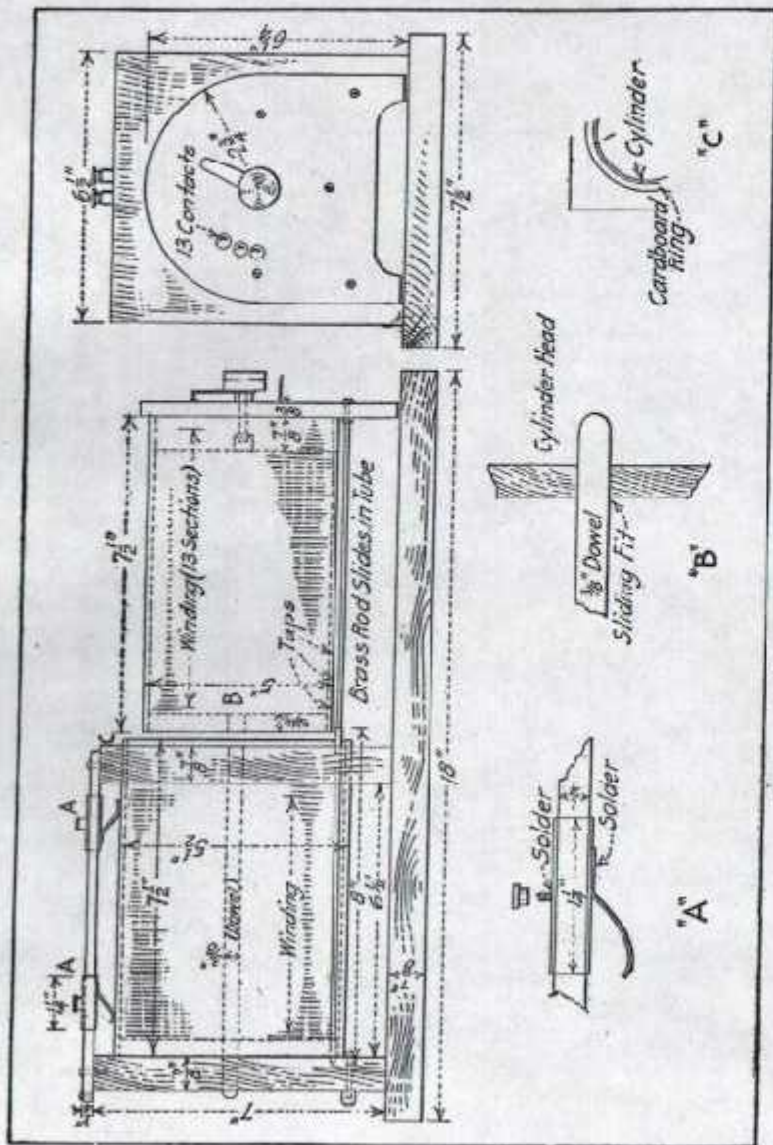

Fig. 3. Detail for construction of transformer

length of great utility. The figure quoted is based upon the use of the instrument with the average antenna of the advanced amateur.

The construction involves some careful but not necessarily difficult wood-working. A lathe is not at all necessary, although it is, as always, desirable. If a jig saw is available, most of the turning can be avoided. The only real, good excuse for a lathe is in turning the wooden heads that fit into the cardboard cylinders, and also in winding the cylinders.

substitute for the lathe in both turning and winding operations is an ordinary polishing head that can be purchased for a couple of dollars. The discs may be mounted on the taper thread and a very presentable job of turning done with the broken end of a flat file held on a simple rest.

The jig saw, however, is an essential. If one of the foot-power variety is not available, the hand fret saw frame will answer, although in our experience there is no comparison between the two.

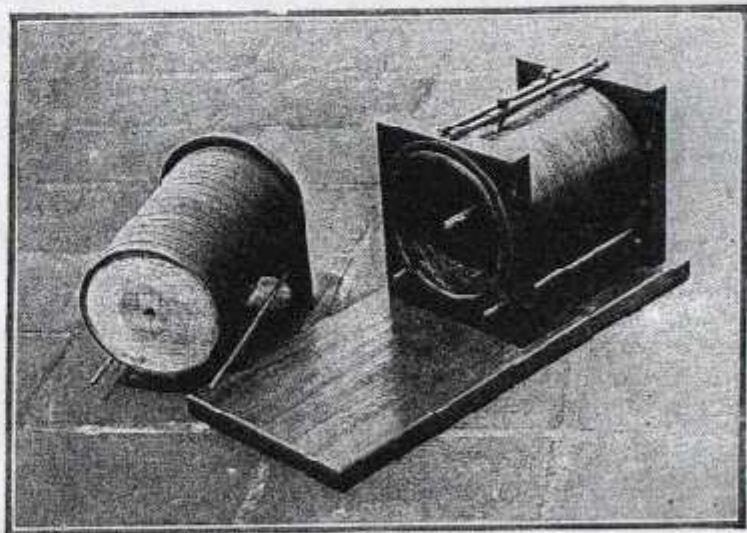

Fig. 2. Receiving transformer showing dowel arrangement for sliding

The latter operation may readily be done, however, by mounting the cylinders between centers on a base board. Another effective

The woodwork had best be done first of all. Figs. 1, 2 and 3 will give a good idea of the appearance and construction of the in-



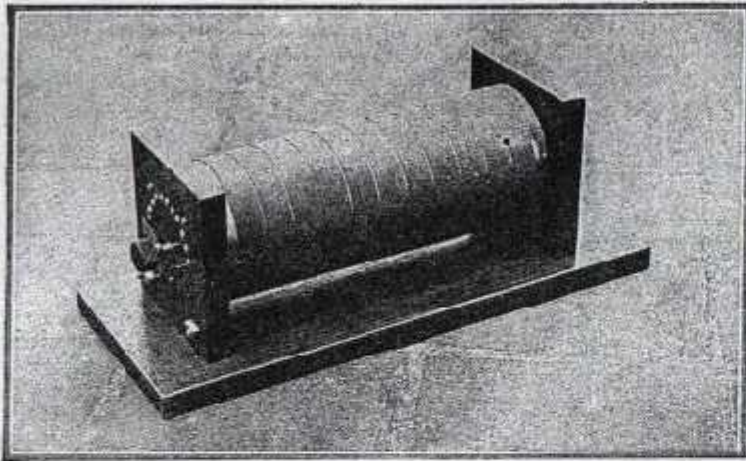

Fig. 4. Loading coil completed

ates, the secondary support is gripped between nuts and washers on the threaded ends of the rods.

We are now ready for the winding. The primary is wound directly upon a cardboard cylinder 5½ in. diameter and 7½ in. long. The winding is No. 24 bare copper wire. The winding is done with two wires wound in parallel and then, after the ends are carefully secured by pushing through holes in the cylinder, and plugging with wooden pegs, one wire may be unwound. This will leave a firm, neat winding of bare copper wire with each turn separated from its neighbor by the thickness of the wire. The winding should be made about 5½ in. long, leaving ½ in. of space at

either end of the cylinder when the latter is mounted in the wooden supports. After the winding is finished, it should be given two generous coats of shellac, taking care to see that the fluid runs down between turns in order that they may be sealed to the surface of the cylinder. The contact path for each slider is to be scraped in the winding after the shellac is quite hard and dry. This operation, however, need not be attempted until the cylinder is mounted and the sliders are in place on their rods.

The secondary winding consists of a single layer of No. 28 S. S. C. magnet wire wound in 13 sections upon a cardboard cylinder 5 in. diameter and 7½ in. long. The winding amounts to a single layer

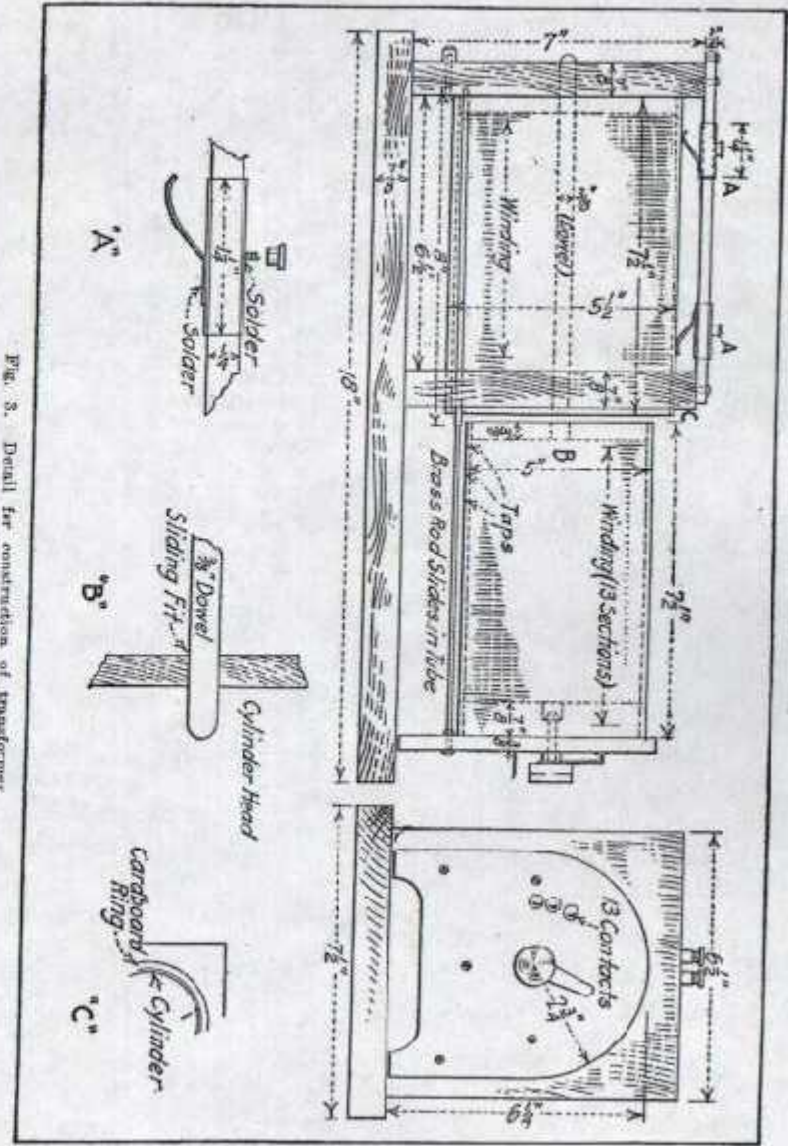

Fig. 3. Detail for construction of transformer



which is wound in the following manner: The winding is started from one end and continued for  $\frac{1}{2}$  in., at which point the hand guiding the wire is jumped to a distance which leaves a space of about 1-16 in. between the finished turn of the section just wound and the beginning of the next section. At the point where the "jump" is made a pin-hole is punched into the cardboard cylinder. Through this hole the tap which leads to the contact point will be made. This process is to be continued until 13 sections have been wound, at which point about  $6\frac{1}{2}$  in. of the surface of the cylinder will have been covered with the wire. Care must be taken to see that the holes through which the taps are taken are in a line, which will, of course, be at the bottom of the cylinder when it is mounted on the secondary support.

There are a number of ways of securing the silk-covered wire to the cardboard cylinder, but the best method in our experience is first to coat the cylinder with two or three applications of shellac, allowing the varnish to become "tacky" before placing the winding. This method will firmly secure each turn to the cylinder, and at the same time will obviate the necessity for shellacing the silk after the winding is complete.

The taps are made with lengths of slightly heavier bare copper

wire pushed through the holes in the cylinder and soldered with a very fine copper, one to each of the "cross over" wires between sections. These taps should be long enough to extend through the  $\frac{3}{8}$  in. head to make contact with the points upon which the instrument switch bears. Each tap is to be covered with a sleeve of fine rubber tubing to prevent possible short circuits inside the cylinder.

The next operation, before going further with the taps, is to insert the secondary inside the primary after having wound heavy wrapping paper around the primary until it fits closely into the larger tubing. The secondary support with its brass rods firmly secured to it is then to be brought up to the wooden head of the secondary and holes drilled for the wood screws that secure the secondary to the support. The shrewd reader will at once see that this insures accuracy in assembling the component parts of the transformer and precludes the possibility of uneven space between primary and secondary cylinders. When the screws have been driven home, the secondary may be withdrawn and from this point on, the secondary and its supporting piece should not be separated.

The next operation will be to lay out the arc of the circle for the contact points, of which there are 13. The radius of the arc on

instrument. The details and dimensions are given in Fig. 3. The choice of wood rests with the individual, but we favor white-wood. The base,  $7\frac{1}{2}$  in. wide and 18 in. long, is of  $\frac{3}{8}$  in. stock and quite simple. The upright pieces that support the primary are each  $6\frac{1}{2}$  in. wide and 7 in. high, while the thickness may be  $\frac{1}{8}$  in. The piece to the right in Fig. 3 is cut out to receive the cardboard cylinder which is  $5\frac{1}{2}$  in. outside diameter. The left-hand piece is left solid and it has mounted upon it a disc of  $\frac{3}{8}$  in. whitewood turned to fit the inside of the cylinder. The latter should not be permanently secured in its supports until after the holes for the brass tubes indicated in the drawing have been drilled. This operation will be detailed later.

The next step will be to get out the two discs for the secondary cylinder. One of these is of  $\frac{3}{8}$  in. stock, while the other is of  $\frac{7}{8}$  in. wood. They are, of course, to fit the inside of the cylinder tightly. The latter, as the drawing indicates, is 5 in. in outside diameter. The internal diameters of both cylinders will vary a trifle with different makes of cardboard tubing, but it is of little consequence. The thicker disc may be permanently affixed by means of glue and wooden pegs, but the thinner disc must be left removable until after the winding

is finished and connections to the contact points are made.

The front support that holds the secondary may now be worked out with the jig saw, and with this the woodwork proper is finished. This is the time to do the staining and varnishing. If these decorative operations are left until later, the results will be rather unsatisfactory and the task difficult to perform. After the varnish is good and hard, so that handling will not injure the finish, the worker may lay out the centers for drilling the two holes through which pass the supporting brass rods. These holes are  $4\frac{1}{4}$  in. apart on centers and  $1\frac{1}{4}$  in. up from the base. When the centers have been marked and pricked, the front support may be placed on two pieces which hold the primary, and holes drilled through all three while they are clamped together. This will insure alignment of the holes, which is quite essential to prevent binding when the rods are telescoped into the tubes. The holes in the secondary support may be  $\frac{1}{4}$  in., the same as those in the other pieces, for a trifle of leeway is not objectionable to permit of easing up on any bind that may develop when the apparatus is assembled.

The brass tubing and the rods that enter it may then be placed, and the whole arrangement assembled temporarily to determine whether the work has been successful. As the drawing indi-



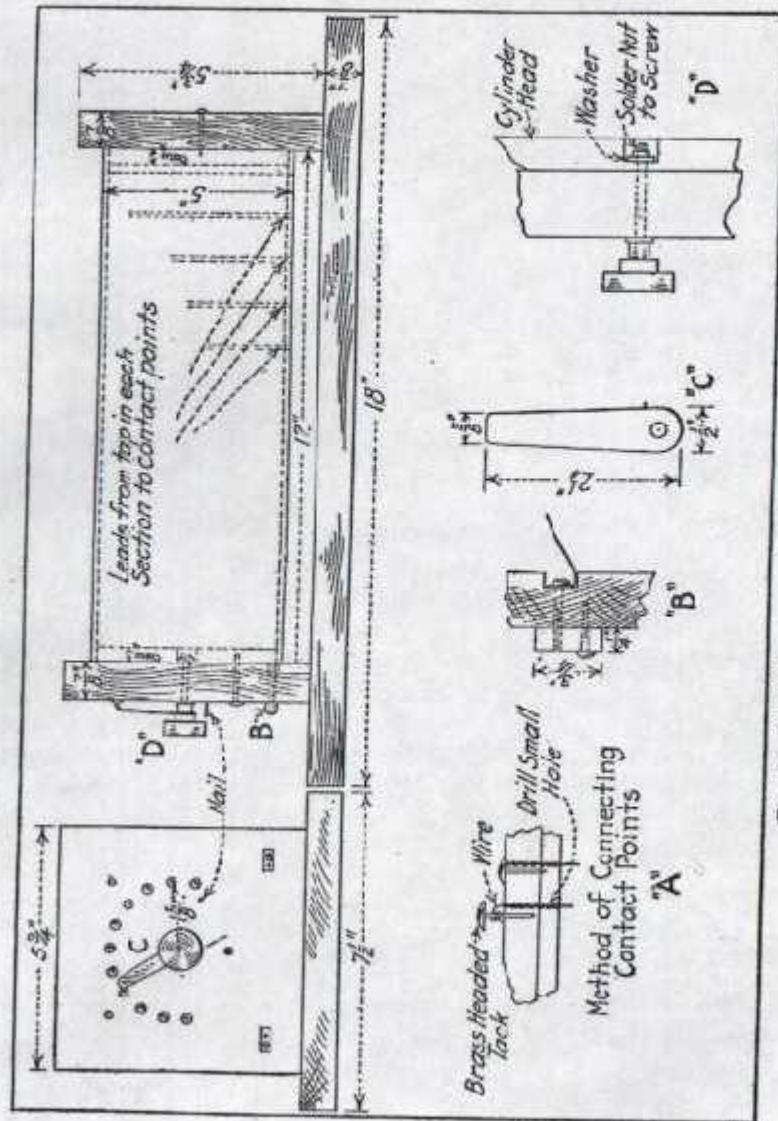

Fig. 5. Detail for construction of loading coil.

shape, and soldered to the bottom of the slider.

Binding posts are not specified, for connection may be made directly to machine screws in the ends of the slider rods in the case of the primary, and to small connection blocks electrically connected with the brass tubes that pass through the primary supports, for the secondary.

#### LOADING INDUCTANCE

The loading inductance consists of a cardboard cylinder wound in a single layer with No. 24 S. S. C. copper magnet wire in 11 sections. Each section is tapped to a contact point in one of the heads as shown in the illustration. As the construction is identical with that of the receiving transformer just described, in so far as mounting the cardboard cylinder, etc., is concerned, we will not go into a lengthy explanation of the construction. All details are given very clearly in Fig. 5, and Fig. 4 shows well the appearance of the finished instrument.

A few hints relative to the standard products used in the construction of both of these coils may not be amiss. The instrument switch used on each coil is a standard product that may be bought in almost any large supply house. The builder is, however, advised to discard the usual brass contact piece and substitute for it a piece of phosphor bronze sheeting cut to the dimensions shown

at *C*, Fig 5, and bent over at the tip so that the contact is made on the edge rather than on the flat surface.

The contact points may be ordinary brass-capped upholstery tacks or they may be oval-head copper rivets. The latter are much to be preferred, but they are more expensive and more difficult to install. If the rivets are used, however, the hole through which the tap wire passes may be made approximately the same size as the shank of the rivet in order that the latter may make contact as the stud is driven home.

If the upholstery tacks are used, the method of connecting shown at *A* should be employed. This insures contact between the wire and the brass head rather than with the steel shank of the tack.

The simple form of connection block that we favor is shown at *B*. This is merely a short length of  $\frac{1}{4}$  in. square brass rod secured to the instrument at the desired point. Connection is made under the heads of brass machine screws in an obvious manner.

The cardboard cylinders for both receiving transformer and loading coil may be obtained from advertisers in this magazine, and the woodwork is best obtained from a local mill which will cut out the pieces to size at a very reasonable figure.

At *D* is shown the method we employ to secure the adjusting



knob which carries the switch making contact with the studs. In the standard product a threaded shank is permanently fastened to the composition knob. The obvious way of securing this switch to the instrument would be merely to place a lock-nut over the first nut that goes on the shank. This method, however, is unreliable and unsatisfactory. Constant use will frequently loosen the nuts after the instrument is entirely assembled, and needless annoyance results therefrom. We used the simple expedient of locking the first nut with a drop of solder after we had secured just the tension we desired to make the knob turn with freedom but without unpleasant looseness.

The *Technical Adviser* is at the disposal of readers who require additional advice or instructions, and the *Service Department* will aid those who have difficulty in obtaining needed materials.

#### PAINT FOR ONE CENT PER POUND

To one gallon of hot, soft water add four pounds of crude sulphate of zinc. Let it stand until it dissolves perfectly, and a sediment will settle at the bottom. Turn the clear solution into another vessel. To one gallon of paint (lead and oil) mix one gallon of the compound. Stir into the paint slowly for 10 or 15 minutes and the paint and com-

ponent will combine perfectly. If too thick thin the mixture with turpentine.

Contributed by J. C. GILLILAND.

#### BORING A HOLE IN BRICK

Any man who wishes to bore a hole in brick and has not a cold chisel on hand will find this home-made chisel very handy. All that it consists of is a piece of galvanized iron pipe about 7 in. long and the diameter de-

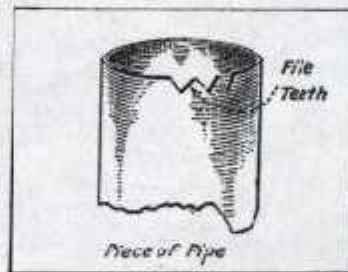

File teeth in one end of the pipe

pends upon the hole you want to bore. In one end of this pipe, teeth must be filed about 1-16 in. apart. You will find that this will bore a clean-cut hole.

Contributed by FRED W. ALLEN.

*If the family is large and the kitchen sink small, try using an oval tin foot tub instead of the round dish pan.*—MARY F. SCOTT.



second inductance or loading coil is connected in series with the primary of the receiving transformer to increase the inductance and therefore the wavelength of the antenna circuit. Where a tuned secondary is desired it is essential that a second loading inductance be placed in the closed oscillatory circuit. It should be noted that it is so

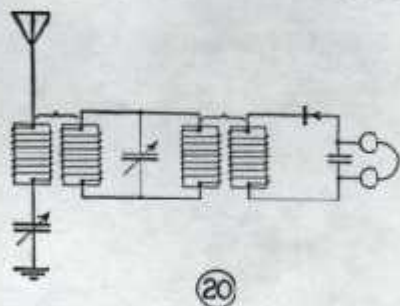

20. The circuit here shown is that of an extremely selective loosely coupled receiving tuner having three circuits. The antenna circuit includes a variable condenser and an inductance which is inductively coupled to a coil of an intermediate circuit. The intermediate circuit is tuned to resonance with the antenna circuit by means of a variable capacity, and has a second inductance which is variably coupled to the detector circuit. In this case the detector circuit is aperiodic.

Altho seldom used by experimenters, this three circuit tuner has found considerably favor in commercial radio service. For about ten years some of the largest steamships afloat have employed this circuit in the form of the well known Marconi

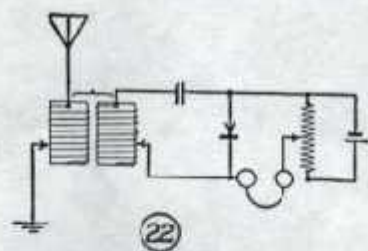

22. This circuit employs a simple loosely coupled tuner but varies from the arrangements previously considered in that a local battery is used. With some detectors, such as carborundum, signal strength is greatly improved by employing a direct current potential of the correct polarity in series with the crystal and the telephones. This is due to the fact that the crystal detector works by virtue of its unilateral conductivity which is more pronounced at certain voltages than at others. To obtain the correct potential a potentiometer of at least 500 ohms is shunted across the battery in the manner shown, and variations of the voltage applied to the detector and telephones are permitted

placed that the secondary condenser is wired across the secondary inductance and loading coil rather than across the secondary alone. As in the case of circuit 11 the loading coils should be placed at right angles to the loose coupler windings so that they will least affect the tuning when they are not in use.

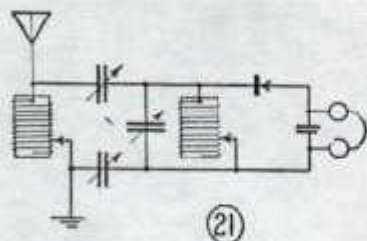

Multiple tuner and some operators favor it.

21. Here we have a two circuit tuner employing electro-static coupling between the tuned circuits. The open circuit is tuned by means of a variable inductance while variations in the wavelength of the closed circuit are accomplished by the variable secondary inductance and the variable condenser. Coupling between the circuits is varied by changing the capacities of the two variable condensers connected between the ends of the two inductances. In a commercial form the shafts of the two are mechanically coupled so that both may be varied by a single knob. This circuit is used in some of the U. S. Navy outfits, both in this way and combined with electro-magnetic coupling.

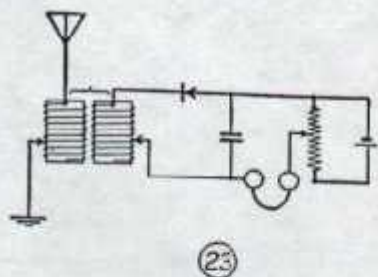

23. Another potentiometer diagram is here shown. The principle upon which this circuit functions is practically identical to that employed in circuit 22. It differs in that the stopping condenser is shunted across the telephones and potentiometer, and the secondary inductance is included in the local battery circuit. While found in some high class commercial equipment this circuit in most cases is less desirable on account of the click caused in the telephones by making and breaking the battery circuit when the inductance is varied.

A potentiometer circuit of the kind shown in diagram 22 or 23 is essential where electrolytic detectors are used.

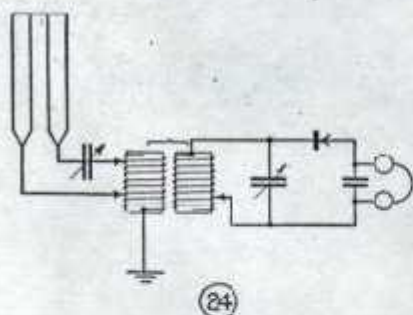

24. A type of antenna not previously referred to is illustrated in this circuit. It is termed a loop antenna but must not be confused with the coil type or directional loops, for it is as efficient as the ordinary aerial and is no more directional. Such an antenna with its attendant tuning arrangement was championed by De Forest in the early days of wireless development and found considerable favor among experimenters at that time.

25. The principle of the dead-end inductance switch is illustrated in this figure. A single circuit receiver is shown only for the sake of simplicity, the dead-end system being applicable to inductances of any circuit, regardless of its complexity.

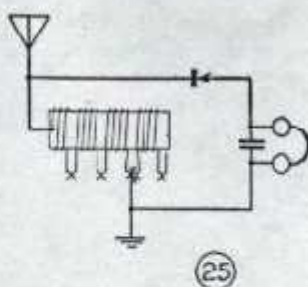

The idea of the device is to remove the unused portions of the inductance from the active part of the circuit so as to minimize absorption and resultant losses. This is quite important where tuners of long wavelength ranges are used, for in these instruments the natural period of the whole winding is very often equal to the wavelength of a signal tuned in on a fractional part of the inductance. Such a condition increases the resistance of the winding enormously, and if efficient reception is to be conducted it is imperative to use a dead-end device for breaking up the inductance into sections to keep the natural period away from the useful wavelengths.

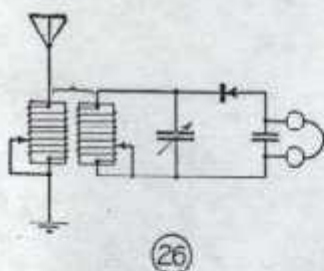

26. Here the end of the inductance, which is usually free, is connected to the variable contact so that the unused portion of the coil is always shorted. To the man who has given little attention to radio frequency circuits but who is familiar with alternating current theory, it would appear that this method would seriously impair the efficiency of the outfit, but as a matter of fact it is used in some of the most popular regenerative tuners. However, there is no doubt but that there are losses due to an arrangement of this kind for the inductance of the coil is reduced while the resistance per turn remains the same. The object of shorting is to prevent the unused inductance from forming an oscillatory circuit whose natural period might be near the wavelength of a desired signal and thereby absorb a considerable amount of energy.

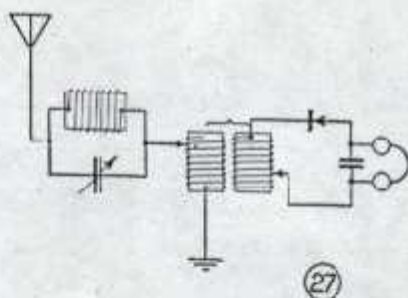

27. This circuit gives a method of reducing interference from signals on a wave differing in length from that of a desired station. This is accomplished by placing an inductance shunted by a condenser in the antenna circuit and tuning them to the frequency of the interfering signal. This simple tuned impedance or radio frequency trap oscillates at the period of the undesired transmitter so that the current flowing in each half is practically equal and opposite in linear direction. Theoretically this neutralizes the current at this wavelength at the point where the receiving tuner is connected, thereby preventing those impulses from travelling thru the primary of the transformer to the ground. The system is quite effective where the interference is caused by an undamped wave transmitter, but does not eliminate as great a portion of damped wave signals.



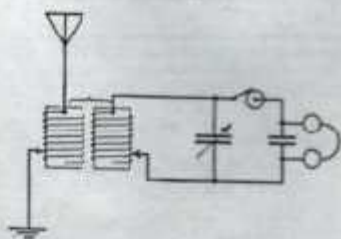

(28)

28. In this diagram we have the connection of a receiving outfit designed for the reception of sustained or undamped waves such as are emitted from arc transmitters, high frequency alternators, and oscillating vacuum tubes. Since undamped waves have no period of oscillation within the range of the human ear, it is necessary to employ in the receiver a device for breaking them up into audible groups. In this circuit an old, simple, and reliable method is given. The tuner does not differ from those previously described, but in place of the usual detector an instrument known as the Poulson ticker is connected. This is

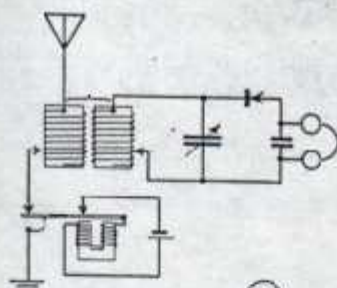

(29)

merely a revolving disc upon which a spring wire or brush is brought to bear. As the disc rotates the light contact interrupts the circuit owing to the irregular surface over which it travels. The make and break does not occur regularly so the note produced in the telephones is not of a musical character. The received energy is accumulated in the secondary or closed circuit of the tuner while the ticker contact is open, and discharged thru the telephones when the circuit is closed. In this way the continuous wave is broken up at a rate which is within the limits of the ear and the received signal is thus made audible.

29 Another system for the reception of undamped waves is illustrated here. A loosely coupled receiving tuner with a crystal detector and telephones comprise the receiver proper, but in series with the ground lead is a make and break device. This serves to interrupt the incoming energy at an audible rate so that groups of oscillations rather than continuous oscillations take place in the circuits. It is these groups which are

actually heard and their frequency determines the tone produced in the telephones by the incoming signal.

The interrupting mechanism is called a chopper and may either consist of a separate set of contacts on a buzzer or a revolving make and break of the commutator type. Its position in the circuit must not necessarily be in the ground lead, but may occupy almost any place in the open, or even the closed oscillatory circuit.

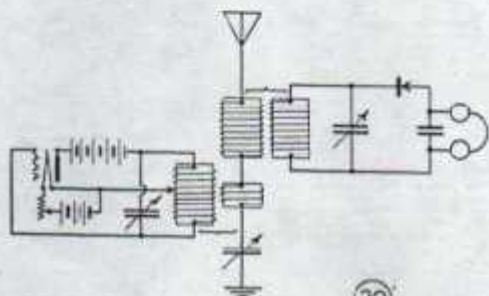

(30)

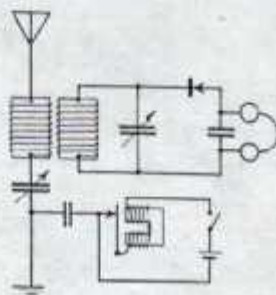

(31)

30. A more elaborate means of breaking up continuous waves so as to produce audible signals is given in this circuit. The usual type of crystal receiver is used, but a local generator of high frequency oscillations is inductively coupled to the primary circuit. This oscillator is tuned to a wavelength differing from that of a desired signal by some frequency within range of the ear. That is, if the incoming signal is being transmitted on a wavelength of 19,000 meters or 30,000 cycles, the local generator should be adjusted to radiate energy at a frequency of 29,000 or 31,000 cycles. This would produce a note in the telephones equal to the difference between the two or 1,000 cycles per second. This is called beat or heterodyne reception. With this system an even tone is produced and its frequency can be regulated to suit the operator. Due to the inherent characteristics of the detector, the efficiency of the receiver on weak signals is considerably increased by super-imposing local oscillations upon the incoming signals, for the value of the current

flowing thru the circuit is built up to a point where slight variations in the signal energy result in greater variations in the telephone current, than would normally be the case.

In this circuit a vacuum tube oscillator is shown, but an arc or other form of high frequency generator will answer the same purpose.

31. A buzzer test circuit is here shown connected to a crystal detector receiving outfit. Its purpose is to assist the operator in determining the most sensitive adjustment of the detector. Various buzzer hook-ups are possible, but the one here given combines simplicity with effectiveness. A battery and a device for opening and closing the circuit are wired in series with the buzzer, while the contact of the instrument is led thru a fixed condenser to the ground. In operation the buzzer is started by closing the circuit and the point of the detector is moved about the surface of the crystal until a spot is found where the buzzer is heard with maximum strength in the telephones.

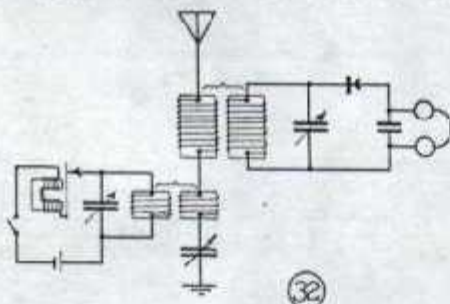

32. It frequently becomes desirable to have a buzzer circuit which will radiate most of its energy on a definite wavelength. Such a hook-up is shown in diagram 32. A tuned oscillating circuit, consisting of a condenser shunted by an inductance, is placed in series with a battery, buzzer and switch. When the switch is closed the buzzer contacts periodically open and close the circuit, setting up oscillations in the tuned circuit at an audio frequency equal to the tone of the buzzer, and on a wavelength determined by the capacity and inductance of the high frequency circuit. The inductance is electromagnetically coupled to the receiving circuit which must be tuned to the wavelength of the buzzer system before any response in the telephones can be expected. The advantage of this circuit over the preceding one is that actual radio frequency energy is supplied for testing the receiver. The best point on the crystal can be more reliably located and any defect in the tuning system will be checked up as well.

33. The Fleming valve detector from which the auction wave developed is shown connected to a loosely coupled tuner in this diagram. The action of the detector is based upon the theory that in a vacuum negative charges will flow from a heated to a cold electrode and not in the reverse direction. The current flow is opposite in direc-

tion to the electronic stream. The cold electrode is termed the anode or plate, while the heated member is called the filament. To produce the required temperature, a battery is connected to the cathode, or filament, thru a variable resistance. Telephones shunted by a condenser are wired in series with a tuning inductance between the filament and plate to form the external circuit of the valve. Connection to the filament is made thru a potentiometer which may be regulated to place the proper charge on the plate.

In operation the potentiometer is adjusted to a point where a feeble current will continually flow thru the circuit. When a signal is tuned in, a radio frequency alternating current is induced in the closed circuit, tending to reverse the plate potential at a rapid rate. The alternation which assists the local potential increases the current flowing thru the telephones while the opposite alternation decreases it slightly. In this way a pulsating direct current rather than an alternating current is applied to the telephones. Owing to the fact that the effect of the positive side of the received current is greater than the negative, each group of oscillations, instead of single oscillations affects the telephone diaphragms, thereby producing audible sounds.

The Fleming valve is no more sensitive than the crystal detector but is considerably more reliable.

